



exceptionally crafted

**INSTRUMENTS**



comed  
operate better with us



GB

### The Company |

With over three decades of experience, we are serving the healthcare industry with the high precision quality, innovative and reliable handheld surgical instruments for all surgical needs. With a centralized manufacturing system, continuous development and ultimate precision through state-of-the-art machines we are leading towards first class instruments manufacturing and provision of customer specified products.

FR

### L'entreprise |

Avec plus de trois décennies d'expérience, nous servons l'industrie de la santé avec des instruments chirurgicaux portables de haute précision, innovants et fiables pour tous les besoins chirurgicaux. Avec un système de fabrication centralisé, un développement continu et une précision ultime grâce à des machines de pointe, nous nous dirigeons vers la fabrication d'instruments de première classe et la fourniture de produits spécifiés par le client.

DE

### Die Firma |

Mit über drei Jahrzehnten Erfahrung bedienen wir die Gesundheitsbranche mit hochpräzisen, qualitativ hochwertigen, innovativen und zuverlässigen chirurgischen Handinstrumenten für alle chirurgischen Anforderungen. Mit einem zentralisierten Fertigungssystem, kontinuierlicher Weiterentwicklung und höchster Präzision durch modernste Maschinen führen wir zur erstklassigen Instrumentenherstellung und Bereitstellung kundenspezifischer Produkte.

IT

### L'azienda |

Con oltre tre decenni di esperienza, serviamo il settore sanitario con strumenti chirurgici portatili di alta precisione, innovativi e affidabili per tutte le esigenze chirurgiche. Con un sistema di produzione centralizzato, sviluppo continuo e massima precisione attraverso macchine all'avanguardia, stiamo conducendo verso la produzione di strumenti di prima classe e la fornitura di prodotti specificati dal cliente.

ES

### La empresa |

Con más de tres décadas de experiencia, estamos al servicio de la industria de la salud con instrumentos quirúrgicos de mano innovadores, confiables, de alta calidad y precisión para todas las necesidades quirúrgicas. Con un sistema de fabricación centralizado, desarrollo continuo y máxima precisión a través de máquinas de última generación, nos dirigimos hacia la fabricación de instrumentos de primera clase y el suministro de productos especificados por el cliente.



GB

### Materials |

We manufacture all our products from martensitic stainless steel types (AISI 410, 420, 440) which are the highest quality medical stainless steel available. Our produced instruments can be autoclaved and reprocessed for many times while attaining same level of quality in performance and surface of the instrument, since we do have a strict quality checks on materials used before processing. We intend to provide highest quality instruments and ensure that qualified materials have been used while manufacturing and are not harmful for patients.

FR

### Matériaux |

Nous fabriquons tous nos produits à partir de types d'acier inoxydable martensitique (AISI 410, 420, 440) qui sont l'acier inoxydable médical de la plus haute qualité disponible. Nos instruments produits peuvent être autoclavés et retraités plusieurs fois tout en atteignant le même niveau de qualité en termes de performances et de surface de l'instrument, car nous avons des contrôles de qualité stricts sur les matériaux utilisés avant le traitement. Nous avons l'intention de fournir des instruments de la plus haute qualité et de garantir que des matériaux qualifiés ont été utilisés lors de la fabrication et ne sont pas nocifs pour les patients.

DE

### Materialien |

Wir fertigen alle unsere Produkte aus martensitischen Edelstahlsorten (AISI 410, 420, 440), die den hochwertigsten medizinischen Edelstahl zur Verfügung stellen das Instrument, da wir vor der Verarbeitung einer strengen Qualitätskontrolle der verwendeten Materialien unterzogen werden. Wir beabsichtigen, Instrumente von höchster Qualität bereitzustellen und sicherzustellen, dass bei der Herstellung qualifizierte Materialien verwendet wurden und für Patienten nicht schädlich sind.

IT

### Materiali |

Produciamo tutti i nostri prodotti da tipi di acciaio inossidabile martensitico (AISI 410, 420, 440) che sono l'acciaio inossidabile medico della più alta qualità disponibile. lo strumento, poiché abbiamo un rigoroso controllo di qualità sui materiali utilizzati prima della lavorazione. Intendiamo fornire strumenti della massima qualità e garantire che durante la produzione siano stati utilizzati materiali qualificati e non siano dannosi per i pazienti.

ES

### Materiales |

Fabricamos todos nuestros productos a partir de tipos de acero inoxidable martensítico (AISI 410, 420, 440) que son el acero inoxidable médico de la más alta calidad disponible. el instrumento, ya que tenemos un estricto control de calidad de los materiales utilizados antes de su procesamiento. Tenemos la intención de proporcionar instrumentos de la más alta calidad y asegurarnos de que se hayan utilizado materiales calificados durante la fabricación y que no sean dañinos para los pacientes.

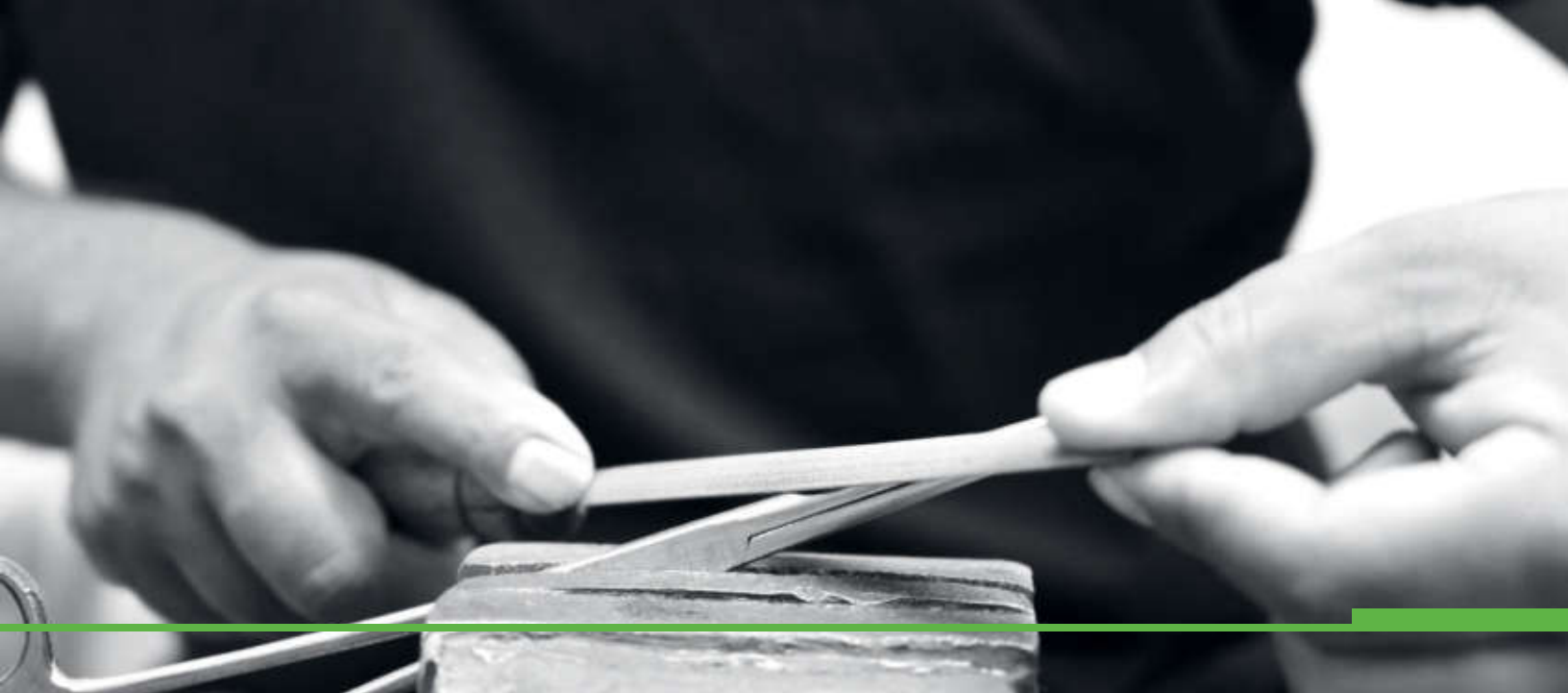

GB

### Production |

In our production line we have skilled craftsmen who are utilizing their best efforts to bring the best quality instruments in the market through use of hi-tech machines. We produce high quality surgical instruments from Japanese and German stainless steel.

DE

### Produktion |

In unserer Produktionslinie haben wir erfahrene Handwerker, die ihr Bestes geben, um durch den Einsatz von Hightech-Maschinen die besten Qualitätsinstrumente auf den Markt zu bringen. Wir produzieren hochwertige chirurgische Instrumente aus japanischem und deutschem Edelstahl.

ES

### Producción |

En nuestra línea de producción contamos con artesanos calificados que están utilizando sus mejores esfuerzos para traer los instrumentos de mejor calidad en el mercado mediante el uso de máquinas de alta tecnología. Producimos instrumentos quirúrgicos de alta calidad de acero inoxidable japonés y alemán.

FR

### Production |

Dans notre ligne de production, nous avons des artisans qualifiés qui font de leur mieux pour fournir les meilleurs instruments de qualité sur le marché grâce à l'utilisation de machines de haute technologie. Nous produisons des instruments chirurgicaux de haute qualité en acier inoxydable japonais et allemand.

IT

### Produzione |

Nella nostra linea di produzione abbiamo abili artigiani che stanno utilizzando i loro migliori sforzi per portare gli strumenti della migliore qualità sul mercato attraverso l'uso di macchine hi-tech. Produciamo strumenti chirurgici di alta qualità in acciaio inossidabile giapponese e tedesco.



GB

### Comed Guarantee |

All instruments manufactured by COMED are 100% guaranteed for 5 years\*, to be free of all kind of defects in workmanship or material. COMED recommends proper cleaning, lubrication and maintenance practices before, during and after use for best performance of the product.

\*The guarantee will be void if it is established that the instruments have been misused.

DE

### Comed Garantie |

Alle Instrumente, die von COMED hergestellt werden, sind zu 100% für 5 Jahre \* garantiert, um frei von jeglichen Verarbeitungs- und Materialfehlern zu sein. COMED empfiehlt angemessene Reinigungs-, Schmier- und Wartungspraktiken vor, während und nach dem Gebrauch, um die beste Leistung des Produkts zu erzielen.

\*Die Garantie erlischt, wenn festgestellt wird, dass die Instrumente missbraucht wurden.

ES

### Garantía Comed |

Todos los instrumentos fabricados por COMED están 100% garantizados por 5 años \*, para estar libres de todo tipo de defectos de mano de obra o material. COMED recomienda prácticas correctas de limpieza, lubricación y mantenimiento antes, durante y después del uso para un mejor rendimiento del producto.

\* la garantía será nula si se establece que los instrumentos han sido mal utilizados.

FR

### Garantie Comed |

Tous les instruments fabriqués par COMED sont garantis à 100% pendant 5 ans \*, pour être exempts de tout défaut de fabrication ou de matériel. COMED recommande des pratiques de nettoyage, de lubrification et d'entretien appropriées avant, pendant et après l'utilisation pour de meilleures performances du produit.

\* la garantie sera annulée s'il est établi que les instruments ont été mal utilisés.

IT

### Garanzia Comed |

Tutti gli strumenti prodotti da COMED sono garantiti al 100% per 5 anni \*, per essere esenti da ogni tipo di difetto di lavorazione o materiale. COMED consiglia le corrette procedure di pulizia, lubrificazione e manutenzione prima, durante e dopo l'uso per ottenere le migliori prestazioni del prodotto.

\* la garanzia sarà annullata se viene stabilito che gli strumenti sono stati utilizzati in modo improprio.



GB

### Research and development |

At COMED we design and develop instruments for the surgery of tomorrow, where we create ideas for new instruments, make modifications in present versions to add more sophisticated products in our portfolio which comes with a combination of precision technology and many years of experience. This results in the very best solutions for user and patients alike.

DE

### Forschung und Entwicklung |

Bei COMED entwerfen und entwickeln wir Instrumente für die Chirurgie von morgen, wobei wir Ideen für neue Instrumente entwickeln, bestehende Versionen modifizieren, um anspruchsvollere Produkte in unser Portfolio aufzunehmen, das eine Kombination aus Präzisionstechnologie und langjähriger Erfahrung bietet. Das Ergebnis sind die allerbesten Lösungen für Anwender und Patienten.

ES

### Investigación y desarrollo |

En COMED diseñamos y desarrollamos instrumentos para la cirugía del mañana, donde creamos ideas para nuevos instrumentos, hacemos modificaciones en las versiones actuales para agregar productos más sofisticados a nuestro portafolio que viene con una combinación de tecnología de precisión y muchos años de experiencia. Esto da como resultado las mejores soluciones tanto para el usuario como para los pacientes.

FR

### Recherche et développement |

Chez COMED, nous concevons et développons des instruments pour la chirurgie de demain, où nous créons des idées pour de nouveaux instruments, apportons des modifications aux versions actuelles pour ajouter des produits plus sophistiqués à notre portefeuille qui associe une technologie de précision et de nombreuses années d'expérience. Il en résulte les meilleures solutions pour l'utilisateur et les patients.

IT

### Ricerca e sviluppo |

In COMED progettiamo e sviluppiamo strumenti per la chirurgia di domani, dove creiamo idee per nuovi strumenti, apportiamo modifiche nelle versioni attuali per aggiungere prodotti più sofisticati nel nostro portafoglio che viene fornito con una combinazione di tecnologia di precisione e molti anni di esperienza. Ciò si traduce nelle migliori soluzioni sia per l'utente che per i pazienti.



GB

### Marketing |

In order to assist our valued customers and medical professionals we provide sophisticated media materials in a user-friendly and comprehensible form upon request to keep them updated about our company and its products offered. The media materials include: Brochures, Printed Catalogs, Electronic CD's and Posters.

DE

### Marketing |

Um unseren geschätzten Kunden und medizinischen Fachkräften zu helfen, stellen wir auf Anfrage anspruchsvolle Medienmaterialien in einer benutzerfreundlichen und verständlichen Form zur Verfügung, um sie über unser Unternehmen und seine angebotenen Produkte auf dem Laufenden zu halten. Zu den Medienmaterialien gehören: Broschüren, gedruckte Kataloge, elektronische CDs und Poster.

ES

### Márketing |

Con el fin de ayudar a nuestros valiosos clientes y profesionales médicos, proporcionamos materiales multimedia sofisticados en una forma fácil de usar y comprensible a pedido para mantenerlos actualizados sobre nuestra compañía y sus productos ofrecidos. Los materiales de los medios incluyen: folletos, catálogos impresos, CD electrónicos y carteles.

FR

### Commercialisation |

Afin d'aider nos précieux clients et professionnels de la santé, nous fournissons des supports médiatiques sophistiqués sous une forme conviviale et compréhensible sur demande pour les tenir au courant de notre société et de ses produits offerts. Le matériel médiatique comprend: des brochures, des catalogues imprimés, des CD électroniques et des affiches.

IT

### Marketing |

Al fine di assistere i nostri stimati clienti e medici professionisti forniamo materiali multimediali sofisticati in un modulo facile da usare e comprensibile su richiesta per tenerli aggiornati sulla nostra azienda e sui suoi prodotti offerti. I materiali multimediali includono: brochure, cataloghi stampati, cd elettronici e manifesti.





GB

### Sales |

COMED manufacture and distribute its products in more than 50 countries worldwide having strongly woven network of business partners. Our top level workmanship ensures that each instrument is ready to easy off the surgeon's day to day activities to the benefit of patients.

DE

### Der Umsatz |

COMED produziert und vertreibt seine Produkte in mehr als 50 Ländern weltweit mit einem starken Netzwerk von Geschäftspartnern. Unsere erstklassige Verarbeitung stellt sicher, dass jedes Instrument bereit ist, die täglichen Aktivitäten des Chirurgen zugunsten der Patienten zu erleichtern.

ES

### Ventas |

COMED fabrica y distribuye sus productos en más de 50 países en todo el mundo con una sólida red de socios comerciales. Nuestra mano de obra de alto nivel garantiza que cada instrumento esté listo para facilitar las actividades cotidianas del cirujano en beneficio de los pacientes.

FR

### Ventes |

COMED fabrique et distribue ses produits dans plus de 50 pays à travers le monde avec un réseau tissé de partenaires commerciaux. Notre travail de haut niveau garantit que chaque instrument est prêt à faciliter les activités quotidiennes du chirurgien au profit des patients.

IT

### I saldi |

COMED produce e distribuisce i propri prodotti in oltre 50 paesi in tutto il mondo, con una fitta rete di partner commerciali. La nostra lavorazione di altissimo livello garantisce che ogni strumento sia pronto per facilitare le attività quotidiane del chirurgo a vantaggio dei pazienti.



GB

### Logistics |

Our logistics team executes most modern logistic to best serve our valued customers. Our extensive stock guarantees quick delivery times, articles which are not available in our ready stock, can be supplied in a short time under special priority service. We can usually deal with your order within 24 hours from receipt.

DE

### Logistik |

Unser Logistikteam führt modernste Logistik durch, um unsere geschätzten Kunden bestmöglich zu bedienen. Unser umfangreicher Lagerbestand garantiert schnelle Lieferzeiten, Artikel, die nicht in unserem Lagerbestand verfügbar sind, können in kurzer Zeit unter besonderer Priorität geliefert werden. Wir können Ihre Bestellung in der Regel innerhalb von 24 Stunden nach Erhalt bearbeiten.

ES

### Logística |

Nuestro equipo de logística ejecuta la logística más moderna para servir mejor a nuestros valiosos clientes. Nuestro amplio stock garantiza tiempos de entrega rápidos, artículos que no están disponibles en nuestro stock listo, pueden ser suministrados en un corto tiempo bajo servicio de prioridad especial. Por lo general, podemos tratar su pedido dentro de las 24 horas posteriores a la recepción.

FR

### Logistique |

Notre équipe de logistique exécute la logistique la plus moderne pour servir au mieux nos précieux clients. Notre stock étendu garantit des délais de livraison rapides, les articles qui ne sont pas disponibles dans notre stock prêt, peuvent être fournis dans un court délai dans le cadre d'un service prioritaire spécial. Nous pouvons généralement traiter votre commande dans les 24 heures suivant la réception.

IT

### La logistica |

Il nostro team logistico esegue la logistica più moderna per servire al meglio i nostri stimati clienti. Il nostro vasto stock garantisce tempi di consegna rapidi, articoli che non sono disponibili nel nostro magazzino pronto, possono essere forniti in breve tempo con un servizio di priorità speciale. Di solito possiamo occuparci del tuo ordine entro 24 ore dal ricevimento.



GB

### Customer Support |

Prompt and experienced after-sales service is very important to COMED. Our friendly and well trained customer support staff will feel pleasure to answer your all queries and requests about our products and services at any time, even if you are not looking for something in our range of products, but we will endeavor to help you with possible solution that best fit to your needs.

DE

### Kundendienst |

Prompter und erfahrener Kundendienst ist für COMED sehr wichtig. Unsere freundlichen und gut geschulten Kundenbetreuer werden Ihnen jederzeit gerne bei allen Fragen und Wünschen zu unseren Produkten und Dienstleistungen zur Verfügung stehen, auch wenn Sie nicht auf der Suche nach etwas in unserer Produktpalette sind, aber wir werden uns bemühen, Ihnen zu helfen Lösung, die am besten zu Ihren Bedürfnissen passt.

ES

### Atención al cliente |

El servicio postventa rápido y experimentado es muy importante para COMED. Nuestro amable y capacitado personal de atención al cliente se complacerá en responder a todas sus consultas y solicitudes sobre nuestros productos y servicios en cualquier momento, incluso si no está buscando algo en nuestra gama de productos, pero nos esforzaremos para ayudarle con posibles la solución que mejor se adapta a sus necesidades.

FR

### Service client |

Un service après-vente rapide et expérimenté est très important pour COMED. Notre personnel de support client amical et bien formé se fera un plaisir de répondre à toutes vos questions et demandes sur nos produits et services à tout moment, même si vous ne cherchez pas quelque chose dans notre gamme de produits, mais nous nous efforcerons de vous aider. solution la mieux adaptée à vos besoins.

IT

### Servizio Clienti |

Un servizio post-vendita tempestivo ed esperto è molto importante per il COMED. Il nostro staff di assistenza clienti amichevole e ben preparato sarà lieto di rispondere a tutte le vostre domande e richieste sui nostri prodotti e servizi in qualsiasi momento, anche se non state cercando qualcosa nella nostra gamma di prodotti, ma faremo il possibile per aiutarvi con soluzione che si adatta meglio alle tue esigenze.



GB

### Item Number |

At COMED we help you to find the product quicker and in an easy way. You have here detailed description of image, part number and additional information. Every drawing and image in this catalog has only one item number and is pictured just once.

FR

### Numéro d'article |

Chez COMED, nous vous aidons à trouver le produit plus rapidement et plus facilement. Vous avez ici une description détaillée de l'image, le numéro de pièce et des informations supplémentaires. Chaque dessin et image de ce catalogue n'a qu'un seul numéro d'article et n'est représenté qu'une seule fois.

DE

### Artikelnummer |

Bei COMED helfen wir Ihnen, das Produkt schneller und einfacher zu finden. Sie haben hier eine detaillierte Beschreibung von Bild, Teilenummer und zusätzlichen Informationen. Jede Zeichnung und jedes Bild in diesem Katalog hat nur eine Artikelnummer und ist nur einmal abgebildet.

IT

### Codice articolo |

A COMED ti aiutiamo a trovare il prodotto più velocemente e in modo semplice. Hai qui la descrizione dettagliata di immagine, numero di parte e informazioni aggiuntive. Ogni disegno e immagine in questo catalogo ha un solo numero di articolo e viene raffigurata una sola volta.

ES

### Número de artículo |

En COMED te ayudamos a encontrar el producto de manera más rápida y fácil. Aquí tiene una descripción detallada de la imagen, número de pieza e información adicional. Cada dibujo e imagen en este catálogo tiene solo un número de artículo y se representa solo una vez.

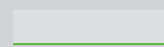

standard instrument identification  
Standard-Instrumentenidentifikation  
identificación estándar del instrumento  
identification d'instrument standard  
identificazione dello strumento standard

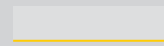

TC instrument identification  
TC-Geräteidentifikation  
Identificación del instrumento TC  
Identification de l'instrument TC  
Identificazione dello strumento TC

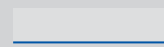

Titanium instrument identification  
Identifizierung des Titan-Instruments  
Identificación del instrumento de titanio  
Identification de l'instrument en titane  
Identificazione dello strumento in titanio

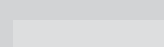

Super Cut instrument identification  
Super Cut Instrumentenidentifikation  
Identificación del instrumento Super Cut  
Identification de l'instrument Super Cut  
Identificazione dello strumento Super Cut

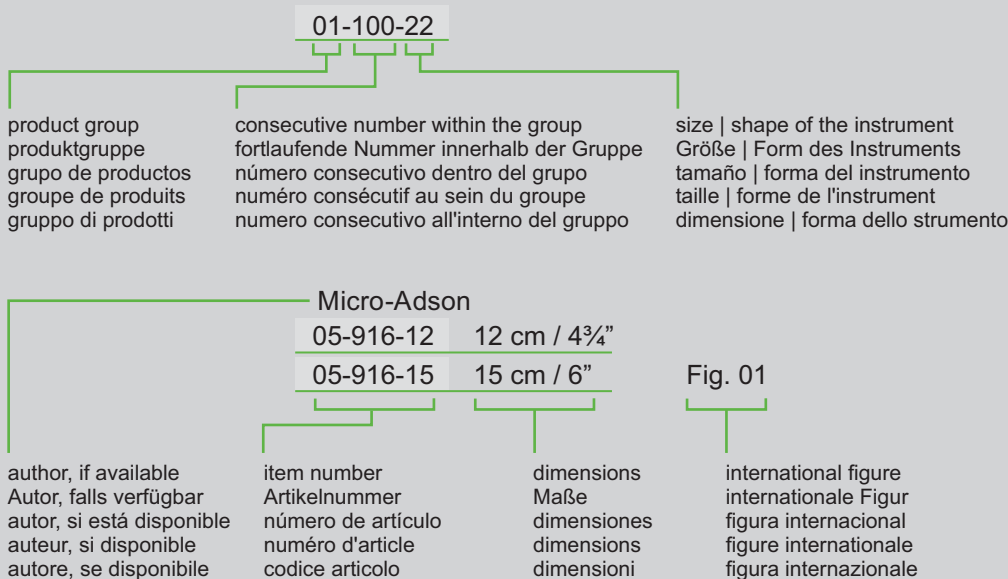

**Conversion Formulae**

- 1cm = .3937 inches
- 1cm = 10mm
- 1mm = .03937 inches
- 1mm = .10cm
- 1 inch = 2.54cm
- 1 inch = 25.40mm
- 1 foot = 30.48cm
- 1 foot = 304.80mm

**Inches to cm & mm**

Inch	mm	cm
1"	25	2.5
2"	51	5.0
3"	75	7.5
3.5"	90	9.0
4"	100	10
4.5"	115	11.5
5"	125	12.5
5.5"	140	14
6"	150	15
6.5"	165	16.5
7"	180	18
7.5"	190	19
8"	200	20
8.5"	215	21.5
9"	230	23
9.5"	240	24
10"	250	25
10.5"	268	26.8
11"	280	28
12"	305	30.5
13"	330	33
14"	355	35.5
15"	380	38
16"	405	40.5
17"	430	43
18"	455	45.5
19"	480	48
20"	500	50

**Inches fractions to decimals, cm & mm**

Inch	Decimal	mm	cm
1/32	0.031	0.79	0.08
1/16	0.063	1.59	0.16
3/32	0.094	2.38	0.24
1/8	0.125	3.18	0.32
5/32	0.156	3.97	0.40
3/16	0.188	4.76	0.48
7/32	0.219	5.56	0.56
1/4	0.250	6.35	0.64
9/32	0.281	7.14	0.71
5/16	0.313	7.94	0.79
11/32	0.344	8.73	0.87
3/8	0.375	9.53	0.95
13/32	0.406	10.32	1.03
7/16	0.438	11.11	1.11
15/32	0.469	11.91	1.19
1/2	0.500	12.70	1.27
17/32	0.531	13.49	1.35
9/16	0.563	14.29	1.43
19/32	0.594	15.08	1.51
5/8	0.625	15.88	1.59
21/32	0.656	16.67	1.67
11/16	0.688	17.46	1.75
23/32	0.719	18.26	1.83
3/4	0.750	19.05	1.91
25/32	0.781	19.84	1.98
13/16	0.813	20.64	2.06
27/32	0.844	21.43	2.14
7/8	0.875	22.22	2.22
29/32	0.906	23.02	2.30
15/16	0.938	23.81	2.38
31/32	0.969	24.61	2.46
1	1.000	25.40	2.54



Standard French (Charriere) Gauge  
 Französische Standardspur (Charriere)  
 Ancho de vía estándar francés (Charriere)  
 Jauge française standard (charrière)  
 Calibro standard francese (Charriere)

The standard French, or Charriere, scale (Fr) is generally used in the size calibration of catheters and other tubular instruments. Based on the metric system, each unit is approximately 0.33 mm, differing 0.33 mm in diameter between consecutive sizes.

Example: 15 Fr indicates a diameter of 5 mm, and 30 Fr indicates a diameter of 10 mm.

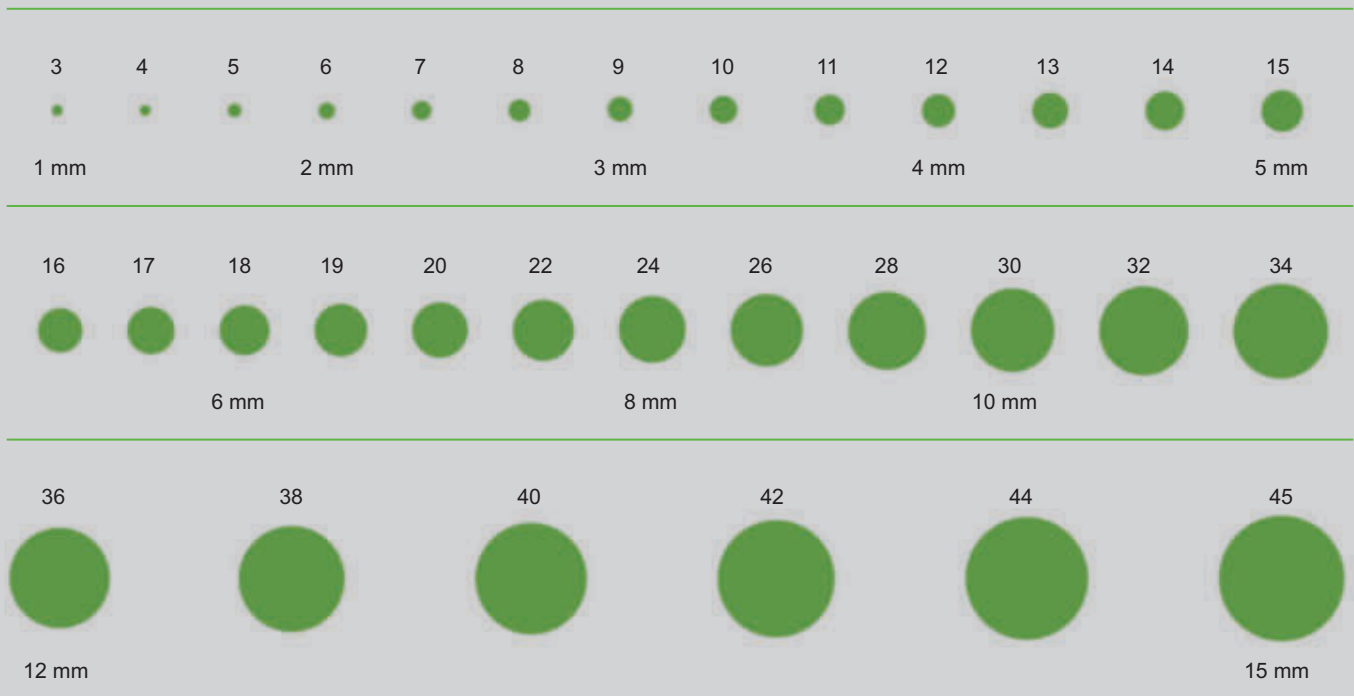

Instrument Angles

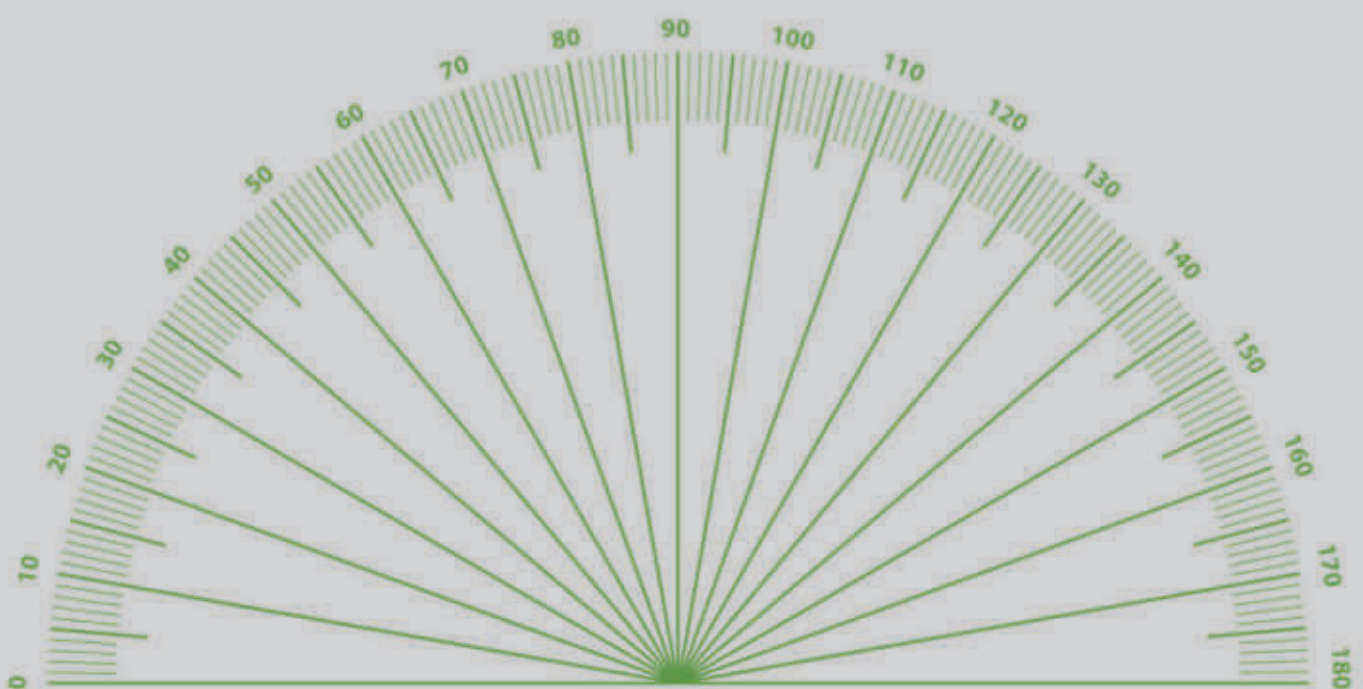

# 01

Diagnostic  
Diagnostik  
Diagnóstico  
Diagnose  
Diagnostici

Page 01 - 34

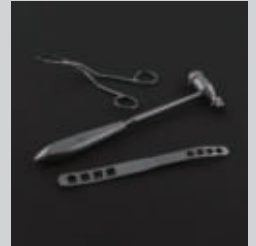

# 02

Aspiration - Probes  
Aspiration - Sonden  
Aspiración - Sondas  
Aspiration - Sondes  
Aspirazione - Sonde

Page 35 - 58



# 03

Scalpels - Knives  
Skalpelle - Messer  
Bisturís - Cuchillos  
Scalpels - Couteaux  
Bisturi - Coltelli

Page 59 - 70

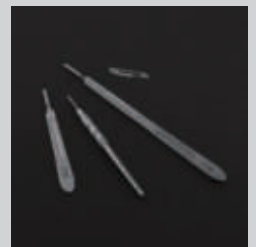

# 04

Scissors  
Schere  
Tijeras  
Ciseaux  
Forbici

Page 71 - 140

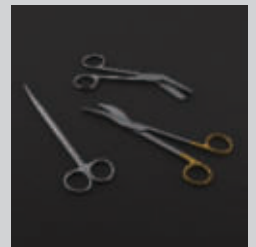

# 05

Dissecting - Tissue Forceps  
Präparieren - Gewebezange  
Disección - Pinzas para tejidos  
Dissection - Pince à tissus  
Dissezione - Forcipe per tessuti

Page 141 - 164

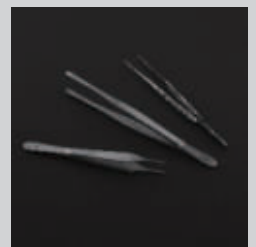

# 06

Artery - Haemostatic Forceps  
Arterie - Blutstillende Pinzette  
Arteria - Pinzas hemostáticas  
Artère - Pince hémostatique  
Arteria - Forcipe emostatico

Page 165 - 204

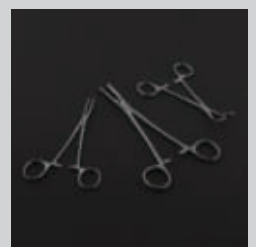

# 07

Cotton Swab Forceps  
Wattestabchen Pinzette  
Pinzas para hisopos de algod3n  
Pincas  cotton-tige  
Pinza per cotton fioc

Page 205 - 212

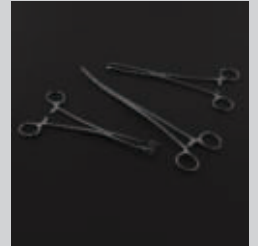

# 08

Retractors  
Wundhaken  
Separadores  
Ecarteurs  
Divaricatori

Page 213 - 286

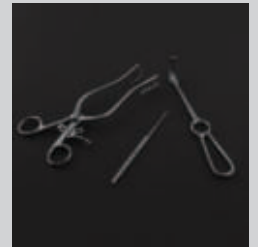

# 09

Suture  
Naht  
Sutura  
Suture  
Sutura

Page 287 - 350

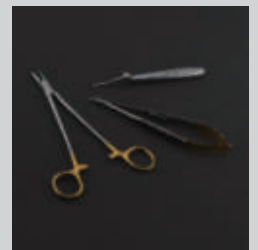

# 10

Cardiovascular Surgery  
Herz-Kreislauf-Chirurgie  
Ciruga Cardiovascular  
Chirurgie cardiovasculaire  
Chirurgia cardiovascolare

Page 351 - 398

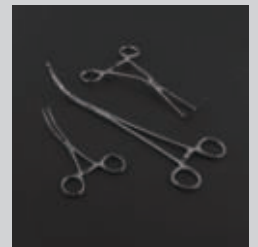

# 11

Dressings  
Verband  
Vendajes  
Pansements  
Bendaggi

Page 399 - 402

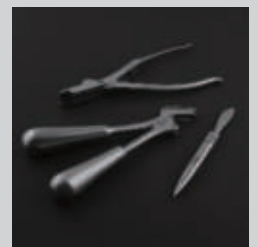

# 12

Bone surgery  
Knochenchirurgie  
Ciruga 3sea  
Chirurgie osseuse  
Chirurgia ossea

Page 403 - 496

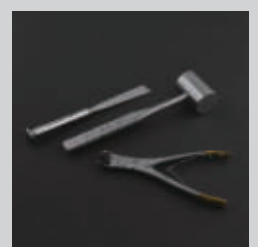



13

Micro-and neuro surgery  
Mikro-und Neurochirurgie  
Cirugía micro y neuro  
Chirurgie micro et neuro  
Micro-e Neuro-Chirurgia

Page 497 - 602

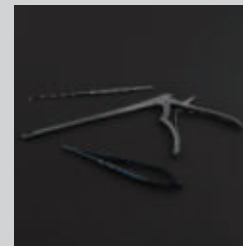

14

Thorax - Lung  
Thorax - Lunge  
Tórax - Pulmón  
Thorax - Poumon  
Torace - Polmone

Page 603 - 618



15

Stomach - Intestine  
Magen - Darm  
Estómago - Intestino  
Estomac - Intestin  
Stomaco - Intestino

Page 619 - 644

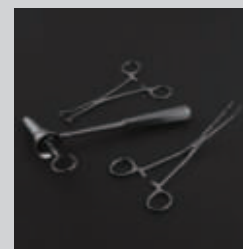

16

Urology  
Urologie  
Urología  
Urologie  
Urologia

Page 645 - 660

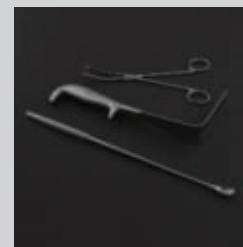

17

Gynecology  
Gynäkologie  
Ginecología  
Gynécologie  
Ginecologia

Page 661 - 706

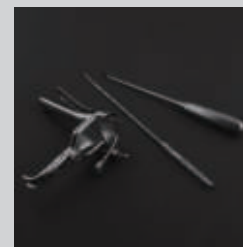

18

ENT  
HNO  
ORL  
ORL  
ORL

Page 707 - 804

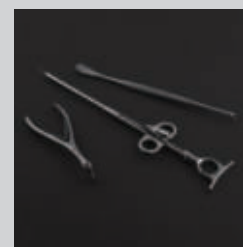

19

Autopsy  
Autopsie  
Autopsia  
Autopsie  
Autopsia

Page 805 - 818

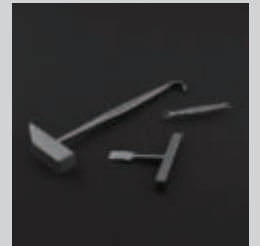

20

Dermatology - Hollowware  
Dermatologie - Hohlware  
Dermatología - Hueco  
Dermatologie - Creuse  
Dermatologia - Hollowware

Page 819 - 832



21

Sterilization  
Sterilisation  
Esterilización  
Stérilisation  
Sterilizzazione

Page 833 - 878



NI

Numeric Index  
Numerischer Index  
Índice numérico  
Index numérique  
Indice numerico

Page 879 - 924

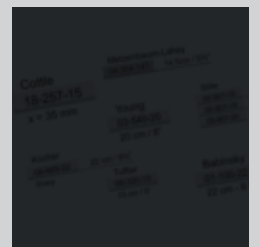



Diagnosics – Anesthesia  
Diagnostik – Anästhesie  
Diagnóstico – Anestesia  
Diagnostic – Anesthésie  
Diagnostica – Anestesia



Babinsky  
01-100-22  
22 cm - 8 3/4"



Rabiner  
01-101-23  
23 cm - 9 1/4"



Queen's Hammer  
01-108-35  
35 cm - 13 3/4"  
Plastic handle



**Wartenberg**  
01-102-19  
19 cm - 7 ½"



**Buck**  
01-103-18  
18 cm - 7"



**Traube**  
01-104-18  
18 cm - 6 ¼"



**Taylor**  
01-105-18  
18 cm - 7"  
01-105-20  
20 cm - 8"



**Berliner**  
01-106-20  
20 cm - 8"



**Déjerine**  
01-107-20  
20 cm - 8"

Set 1  
01-108-00

Ophthalmoscope set  
Ophthalmoskop-Besteck  
Ophtalmoscopio  
Trousse à ophtalmoscopie  
Ofthalmoscopio



Set 2  
01-109-00

Universal set  
Universal-Besteck  
Estuche universal  
Trousse universelle  
Astuccio universale





Set 3  
01-110-00

Combination set  
Kombinations-Besteck  
Estuche combinado  
Trousse combinée  
Astuccio combinato



Set 4  
01-111-00

Otoscope set  
Otoskop-Besteck  
Otoscopio  
Trousse à otoscopie  
Otoscopio



Pinard

01-112-18

18 cm - 7"

Wood  
 Holz  
 Madera  
 Bois  
 Legno



Pinard

01-113-15

15 cm - 6"

Aluminium  
 Aluminium  
 Aluminio  
 Aluminium  
 Alluminio

Duplex

01-114-04 4.7cm - 1 3/4"

for adults  
 für Erwachsene  
 para adultos  
 pour adultes  
 per adulti

Baby-Duplex

01-115-15 4.7cm - 1 3/4"

for children  
 für Kinder  
 para niños  
 pour enfants  
 per bambini



Anestophon

01-116-04 4.7cm - 1 3/4"

for nurses, simple  
 für Schwestern, einfach  
 para enfermeras, simple  
 pour infirmières, simple  
 per infermiere, semplice







**Ziegler**

01-117-09 9 cm - 3 ½" Ø

Head mirror with black plastic head band  
Stirnspiegel mit schwarzem Plastikband  
Espejo frontal con banda de plastica negra  
Miroir frontal avec ruban en plastique noir  
Specchio frontale con fascia di plastica nera

01-119-09 9 cm - 3 ½" Ø

Head mirror with white plastic head band  
Stirnspiegel mit weissem Plastikband  
Espejo frontal con banda de plastica blanca  
Miroir frontal avec ruban en plastique blanc  
Specchio frontale con fascia di plastica bianca

**Ziegler**

01-118-09 9 cm - 3 ½" Ø

Head mirror only, with rubber coating  
Reflexspiegel allein, mit Gummifassung  
Espejo frontal solo, con guarnición de goma  
Miroir frontal seul, avec monture en caoutchouc  
Solo specchio frontale, con guarnizione di gomma

01-120-00

Black plastic head band  
Plastikband, schwarz  
Banda de plastica, negra  
Ruban en plastique noir  
Fascia di plastica, nera

01-121-00

White plastic head band  
Plastikband, weiss  
Banda de plastica, blanca  
Ruban en plastique blanc  
Fascia di plastica, bianca

Cold-light head lamp  
Kaltlicht-Stirnlampe  
Lámpara frontal de luz fria  
Eclaireur frontal de lumière froide  
Lampada frontale a luce fredda



**Binner**

01-122-00

Head light, cold-light, adjustable focus,  
working distance 300 mm, field of illumination 70 –120mm Ø

Kaltlicht-Stirnlampe mit verstellbarer Fokussierlinse,  
Arbeitsabstand 300mm, Leuchtfeldgröße 70 – 120mm Ø

Lámpara frontal, luz fria, focus ajustable,  
distancia de trabajo 300mm, campo de iluminación 70 – 120mm Ø

Eclaireur frontal, lumière froide, focus ajustable,  
distance de travail 300 mm, champ d'illumination 70 – 120mm Ø

Lampada frontale, luce fredda, con lente a focale variabile,  
distanza di lavoro 300 mm, campo d'illuminazione 70 – 120mm Ø



Clar

01-123-00 10 cm Ø, 6 V

Head light complete  
Stirnlampe komplett  
Lámpara frontal, completa  
Eclaireur frontal complet  
Lampada frontale, completa

01-124-00 10 cm Ø, 6 V

Head light with cable, frame and mirror, without head band  
Stirnlampe mit Kabel, Fassung und Spiegel, ohne Stirnreifen  
Lámpara frontal, con cable, armadura y espejo, sin banda  
Eclaireur frontal avec cable, douille et miroir, sans ruban  
Lampada frontale con cavo, supporto e specchio, senza fascia



Mini-Clar

01-125-00 5 cm Ø, 6 V

complete  
komplett  
completa  
complet  
completa

Clar

01-126-05 5 cm - 2" Ø

01-126-10 10 cm - 2" Ø

Spiegel aus Glas, ohne Fassung  
Head mirror glass, without frame  
Miroir frontal en vitre, sans douille  
Espejo frontal de cristal, sin armadura  
Vetro specchio, senza supporto

Clar

01-127-00

Spezial-Gelenkverbindung  
Special socket joint  
Assemblage articulé spécial  
Conexión  
Giunto di connessione speciale

Clar

01-128-00

Stirnreifen allein  
Head band only  
Ruban seul  
Banda sola  
Solo fascia frontale

01-129-00 6 V

Glühbirne  
Bulb  
Ampoule  
Bombilla  
Lampadina



Transformer – stepless adjustable  
Transformator – stufenlos einstellbar  
Transformador – regulación continua  
Transformateur – à réglage continue  
Trasformatore – regolabile in continuità

01-130-00

Input 220 V/ 50 Hz ~  
Output 0–10 V/ 3 W =

**Binocular**

01-131-00

2.5 times enlargement, 340 mm working distance, field of vision 90 mm Ø, complete.  
Pupillary distance adjustable from 48 mm–77 mm. Individual adjustable angle of inclination.  
Weight of the optic 42g.

2.5 fache Vergrößerung, 340 mm Arbeitsabstand, Sichtfeld > 90 mm Ø, komplett.  
Pupillenabstand einstellbar von 48 mm–77 mm. Neigungswinkel individuell justierbar.  
Gewicht der Optik 42g.

2.5 veces aumento, distancia de trabajo 340 mm, campo de visión >90mm Ø, completo.  
Distancia interpupilar ajustable de 48 mm–77 mm. Angulo de inclinación ajustable individual.  
Peso de la optica 42g.

2.5 fois grossissement, distance de travail 340 mm, champ de vision >90mm Ø, complèt.  
Ecart interpupillaire ajustable de 48 mm–77 mm. Angle d'inclinaison ajustable individuellement.  
Poids de l'optique 42g.

Ingrandimento: 2.5 volte, distanza di lavoro 340 mm, campo di visione >90mm Ø, completo.  
Distanza interpupillare regolabile da 48 mm–77 mm. Angolo di inclinazione regolabile individualmente.  
Peso dell'ottica 42g.



01-132-00

Kopfband  
Head band  
Ruban  
Banda  
Fascia

Sphygmomanometers  
Blutdruckmessgeräte  
Esfigmomanometros  
Tensiomètres  
Sfigmomanometri

**Manometer**  
Fig. 1

01-133-00

Calibrated  
Geeicht  
Calibado  
Calibré  
Calibrato



**Manometer**  
Fig. 2

01-134-00

non calibrated  
ungeeicht  
no calibrado  
non calibré  
non calibrato



**Manometer**  
Fig. 3

01-135-00

Mercury blood pressure manometer, non calibrated  
Quecksilber-Blutdruckmessapparat, ungeeicht  
Manómetro de mercurio, no calibrado  
Tensiomètre à mercure, non calibré  
Manometro a mercurio, non calibrato

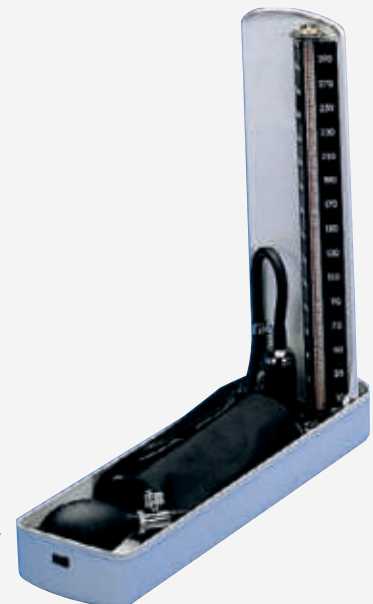



Collin  
Fig. 1

01-136-12

12.5 cm - 5"

for children, kg-scale  
für Kinder, kg-Einteilung  
para niños, graduación en kg  
pour enfants, échelle en kg  
per bambini, graduazione in kg

Fig. 2

01-137-12

12.5 cm - 5"

for adults, kg-scale  
für Erwachsene, kg-Einteilung  
para adultos, graduación en kg  
pour adultes, échelle en kg  
per adulti, graduazione in kg

Fig. 3

01-138-12

12.5 cm - 5"

for adults, lbs-scale  
für Erwachsene, lbs-Einteilung  
para adultos, graduación en lbs  
pour adultes, échelle en lbs  
per adulti, graduazione in lbs



Bertillon

01-139-32

32 cm - 12 1/2"



Moeltgen

01-140-24

24 cm 9 1/2"

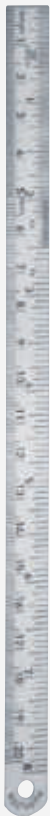

Magda  
Fig. 1

01-141-10	10 cm - 4"
01-141-15	15 cm - 6"
01-141-20	20 cm - 8"
01-141-30	30 cm - 12"
01-141-50	50 cm - 20"



Magda  
Fig. 2

01-142-50	50 cm - 20"
X-ray ruler	
Röntgen-Messstab	
Regla para rayos X	
Règle rayons X	
Misuratore per raggi X	



Vernier

01-143-21	01-144-21	21 cm - 8 1/4"
Aluminium	Steel	
Aluminium	Stahl	
Aluminio	Acero	
Aluminium	Acier	
Alluminio	Accaio	



Castroviejo

01-145-08	8 cm - 3 1/4"
-----------	---------------



Gauge

01-146-15	01-147-15	150 cm - 60"
Steel	Wax cloth	
Stahl	Wachs	
Acero	Cerada	
Acier	Toile cirée	
Acciaio	Cera	



**Welzer**

01-152-16 16 cm - 6 ¼"

Wood  
 Holz  
 Madera  
 Bois  
 Legno



**Wavy**

01-153-14 14.5 cm - 5 ¾"



**Kroenig**

01-154-15 15 cm - 6"



**Mayo**

01-155-17 17 cm - 6 ¾"



**Bruenings**

01-156-19  
 19 cm - 7 ½"



**Frenzel**

01-157-16  
 16.5 cm - 6 ½"



**Lack**

01-130-13 13 mm  
 01-130-19 19 mm  
 01-130-22 22 mm



**Wieder**

01-158-15  
 15 cm - 6"



01-158-14  
 14 cm - 5 ½"





**Bosworth**  
01-159-14  
14.5 cm - 5 3/4"



**Tobold**  
01-160-14  
14.5 cm - 5 3/4"



**Hartmann**  
01-161-15  
15 cm - 6"



**Andrew**  
01-162-11  
11 cm - 4 3/4"



**Young**  
01-163-17  
17 cm - 6 3/4"

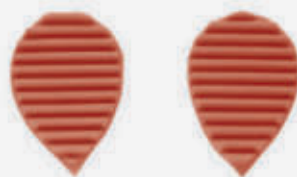

01-163-00  
1 Pair rubber-inserts  
1 Paar Ersatz Gummi-Einsätze  
1 Juego de insertos de goma  
1 Paire des inserts en caoutchouc  
1 Paio d'inserti di gomma



**Collin**  
01-164-16 16 cm - 6 1/4"  
01-164-17 17 cm - 6 3/4"  
01-164-19 19 cm - 7 1/2"

Cheek retractors  
 Wangenhalter  
 Separador de mejillas  
 Ecarteur des joues  
 Divaricatori per guancia



**Sternberg**

01-165-12	12 cm - 4 3/4"
01-165-14	14 cm - 5 1/2"
01-165-16	16 cm - 6 1/4"

Catheter forceps  
 Katheterzangen  
 Pinzas para catéteres  
 Pincés pour cathéters  
 Pinze per catetere



**Magill**

01-166-17

17 cm - 6"  
 Infant



01-166-20

20 cm - 8"  
 Child



01-166-25

25 cm - 9"  
 Adult





The English Macintosh is similar to the conventional Macintosh except that the flange is curved and lower at the handle end. Two studies have proved that this blade provided better results than other commonly used blades.



Fig. 00



Fig. 0



Fig. 1



Fig. 2



Fig. 3



Fig. 4



Fig. 5

Code	Description	Fig.	Size
01-281-00	Premature	00	68 mm
01-281-0	Neonate	0	80 mm
01-281-1	Infant	1	92 mm
01-281-2	Child	2	105 mm
01-281-3	Medium Adult	3	135 mm
01-281-4	Large Adult	4	155 mm
01-281-5	X-Large	5	175 mm

The Miller is one of the most popular blades. The tongue is straight with a slight upward curve near the tip. In cross-section the flange, web, and tongue form a C with the top fattened. Placing the bulb on the right side allows it to be protected by the flange. Several modifications have been described. In comparing the Macintosh and Miller blades, it was found that force, head extension and cervical spine movement were less with the Miller.



Fig. 00



Fig. 2



Fig. 0



Fig. 3



Fig. 1



Fig. 4

Code	Description	Fig.	Size
01-282-00	Premature	00	65 mm
01-282-0	Neonate	0	78 mm
01-282-1	Infant	1	102 mm
01-282-2	Child	2	154 mm
01-282-3	Medium Adult	3	195 mm
01-282-4	Large Adult	4	205 mm

Specially designed and constructed with high quality stainless steel AISI 304.  
 High quality German optical fibers loaded with 4.5mm bundle for best optimum light transmission.

Exceptionally high light intensity with LED illumination (8000-10000 LUX).

With this integrated FO light conductor, there are no extra cavities or light path to become contaminated.

Smooth and low profile blade design which gives no chance of damaging teeth and upper part of mouth.

Integrated light guide blade design for quick cleaning and sterilization without extra effort for connecting screw.

Compatible with all handles of ISO 7376 (Green System).

Autoclaving at 134 C /5 min. maximum light output with 3000-4000 cycles.



Code	Description	Fig.	Size
01-283-0	Neonate	0	80 mm
01-283-1	Infant	1	93 mm
01-283-2	Child	2	114 mm
01-283-3	Medium Adult	3	135 mm
01-283-4	Large Adult	4	155 mm
01-283-05	X-Large	5	175 mm

Specially designed and constructed with high quality stainless steel AISI 304.  
 High quality German optical fibers loaded with 4.5mm bundle for best optimum light transmission.

Exceptionally high light intensity with LED illumination (8000-10000 LUX).

With this integrated FO light conductor, there are no extra cavities or light path to become contaminated.

Smooth and low profile blade design which gives no chance of damaging teeth and upper part of mouth.

Integrated light guide blade design for quick cleaning and sterilization without extra effort for connecting screw.

Compatible with all handles of ISO 7376 (Green System).

Autoclaving at 134 C /5 min. maximum light output with 3000-4000 cycles.



Fig. 00



Fig. 2



Fig. 0



Fig. 3



Fig. 1



Fig. 4

Code	Description	Fig.	Size
01-284-00	Premature	00	65 mm
01-284-0	Neonate	0	78 mm
01-284-1	Infant	1	102 mm
01-284-2	Child	2	154 mm
01-284-3	Medium Adult	3	195 mm
01-284-4	Large Adult	4	205 mm

These blades have a flexible tip that is controlled by a lever attached to the proximal end of the blade. When the lever is pushed toward the handle, the tip of the blade is flexed. This laryngoscope may be helpful when a difficult intubation is encountered.

It may be especially useful in patients with minimal neck movement. External laryngeal pressure may further improve the view. Even if the blade does not improve the view of the larynx, it may improve the likelihood of successful intubation by elevating the epiglottis.

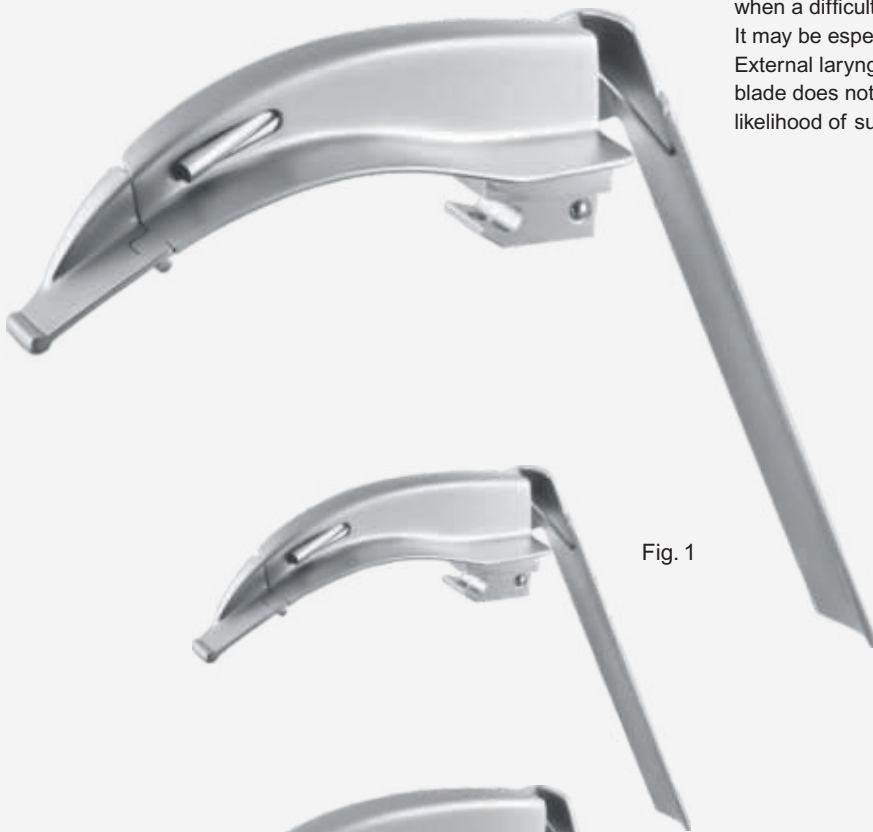

Fig. 1



Fig. 2



Fig. 3

Code	Description	Fig.	Size
01-285-2	Child	2	105 mm
01-285-3	Medium Adult	3	130 mm
01-285-4	Large Adult	4	155 mm

These blades have a flexible tip that is controlled by a lever attached to the proximal end of the blade. When the lever is pushed toward the handle, the tip of the blade is flexed. This laryngoscope may be helpful when a difficult intubation is encountered.

It may be especially useful in patients with minimal neck movement. External laryngeal pressure may further improve the view. However, it will not always improve the view and may worsen it. Even if the blade does not improve the view of the larynx, it may improve the likelihood of successful intubation by elevating the epiglottis. In some patients in whom the view is satisfactory with the Macintosh blade, use of the Flexible tip blade may make the view worse.



Fig. 2



Fig. 3



Fig. 4

Code	Description	Fig.	Size
01-286-2	Child	2	108 mm
01-286-3	Medium Adult	3	130 mm
01-286-4	Large Adult	4	155 mm

Diamond knurled barrel gives strong grip to the user.  
 LED brighter illumination with 60,000 LUX.  
 LED operating time over 50,000 hrs.  
 2 hrs operating time at maximum illumination.  
 Viewing angle at 130 with color temperature color temperature 6500K.  
 Conforms to all Green System blades as per ISO 7376 standard.  
 Simple change of batteries at the base of the handle.  
 Crafted from high quality chrome plated brass.  
 Battery usage is minimized due to the low power consumption.  
 Fully autoclavable @ 134 C for 5 minutes.



**Battery Handles Fiber Optic Xenon, Stainless Steel**

Code	Description	Battery	Size
01-287-01	Infant	1xLithium 123 Size	122 mm
01-287-02	Stubby	2xAA Size	160 mm
01-287-03	Pediatric	2xAA Size	125 mm
01-287-04	Medium	2xC Size	160 mm

**Battery Handles Fiber Optic Xenon, Brass Chrome Plated**

Code	Description	Battery	Size
01-288-01	Infant	1xLithium 123 Size	122 mm
01-288-02	Stubby	2xAA Size	160 mm
01-288-03	Pediatric	2xAA Size	125 mm
01-288-04	Medium	2xC Size	160 mm



**Battery Handles Fiber Optic LED, Stainless Steel**

Code	Description	Battery	Size
01-289-01	Infant	1xLithium 123 Size	122 mm
01-289-02	Stubby	2xAA Size	160 mm
01-289-03	Pediatric	2xAA Size	125 mm
01-289-04	Medium	2xC Size	160 mm

**Battery Handles Fiber Optic LED, Brass Chrome Plated**

Code	Description	Battery	Size
01-290-01	Infant	1xLithium 123 Size	122 mm
01-290-02	Stubby	2xAA Size	160 mm
01-290-03	Pediatric	2xAA Size	125 mm
01-290-04	Medium	2xC Size	160 mm

Macintosh Flexiblade Pro Blades, Fiber Optic, German Profile  
 Macintosh Flexiblade Pro Klingen, Faseroptik, Deutsches Profil  
 Macintosh Flexiblade Pro Blades, Fibra Óptica, Perfil Alemán  
 Macintosh Flexiblade Pro Lames, fibre optique, profil allemand  
 Macintosh Flexiblade Pro Lame, Fibra ottica, Profilo tedesco



Infant 122 mm    Pediatric 160 mm    Stubby 125 mm    Medium 160 mm

**Battery Handles Fiber Optic LED, Stainless Steel**

Code	Description	Battery	Size
01-291-01	Infant	1xLithium 123 Size	122 mm
01-291-02	Stubby	2xAA Size	160 mm
01-291-03	Pediatric	2xAA Size	125 mm
01-291-04	Medium	2xC Size	160 mm

**Replacement Lamps**



LED Lamp



Halogen Lamp

Code	Type	Voltage
01-292-01	Xenon	2.5 V
01-292-02	LED	3.0 V
01-292-03	Halogen	2.5 V
01-292-04	Halogen	3.5 V

**Replacement Fiber Optic Light Guides, English Profile (4 mm)**

Code	Description	For Blades
01-296-00	Miller Blade	00
01-296-0	Miller Blade	0
01-296-1	Miller Blade	1
01-296-2	Miller Blade	2
01-296-3	Miller Blade	3
01-296-4	Miller Blade	4
01-297-00	Macintosh Blade	00
01-297-0	Macintosh Blade	0
01-297-1	Macintosh Blade	1
01-297-2	Macintosh Blade	2
01-297-3	Macintosh Blade	3
01-297-4	Macintosh Blade	4





**Macintosh Fiber Optic Xenon Laryngoscope Sets, English Profile**

Code	Description
01-298-01	Set of 4 Blades 1,2,3,4 with 1 Medium Handle, 1 Replacement Lamp, in Plastic Case.
01-298-02	Set of 5 Blades 0,1,2,3,4 with 1 Medium Handle, 1 Replacement Lamp, in Plastic Case.
01-298-03	Set of 6 Blades 0,1,2,3,4,5 with 1 Medium Handle, 1 Replacement Lamp, in Plastic Case.



**Miller Fiber Optic Xenon Laryngoscope Sets, English Profile**

Code	Description
01-299-01	Set of 4 Blades 1,2,3,4 with 1 Medium Handle, 1 Replacement Lamp, in Plastic Case.
01-299-02	Set of 5 Blades 0,1,2,3,4 with 1 Medium Handle, 1 Replacement Lamp, in Plastic Case.
01-299-03	Set of 6 Blades 0,1,2,3,4,5 with 1 Medium Handle, 1 Replacement Lamp, in Plastic Case.



**Flexible Fiber Optic Xenon Laryngoscope Sets, English Profile**

Code	Description
01-300-01	Set of 2 Blades 3,4 with 1 Medium Handle, 1 Replacement Lamp, in Plastic Case.

**Flexible pro Fiber Optic Xenon Laryngoscope Sets, German Profile**

Code	Description
01-301-01	Set of 2 Blades 3,4 with 1 Medium Handle, 1 Replacement Lamp, in Plastic Case.



**Macintosh Fiber Optic LED Laryngoscope Sets, English Profile**

Code	Description
01-302-01	Mac F.O LED Laryngoscope Set of 4 Blades 1,2,3,4 with 1 Medium Handle, 1 Replacement Lamp, in Plastic Case.
01-302-02	Mac F.O LED Laryngoscope Set of 5 Blades 0,1,2,3,4 with 1 Medium Handle, 1 Replacement Lamp, in Plastic Case.
01-302-03	Mac F.O LED Laryngoscope Set of 6 Blades 0,1,2,3,4,5 with 1 Medium Handle, 1 Replacement Lamp, in Plastic Case.



**Miller Fiber Optic LED Laryngoscope Sets, English Profile**

Code	Description
01-303-01	Miller F.O LED Laryngoscope Set of 4 Blades 1,2,3,4 with 1 Medium Handle, 1 Replacement Lamp, in Plastic Case.
01-303-02	Miller F.O LED Laryngoscope Set of 5 Blades 0,1,2,3,4 with 1 Medium Handle, 1 Replacement Lamp, in Plastic Case.
01-303-03	Miller F.O LED Laryngoscope Set of 6 Blades 00,0,1,2,3,4 with 1 Medium Handle, 1 Replacement Lamp, in Plastic Case.



**Flexible Fiber Optic Led Laryngoscope Sets, English Profile**

Code	Description
01-304-01	MacFlex F.O LED Laryngoscope Set of 2 Blades 3,4 with 1 Medium Handle, 1 Replacement Lamp, in Plastic Case.

**Flexible pro LED Laryngoscope Sets, German Profile**

Code	Description
01-305-01	Set of 2 Blades 3,4 with 1 Medium Handle, 1 Replacement Lamp, in Plastic Case.

The English Macintosh is similar to the conventional Macintosh except that the flange is curved and lower at the handle end. Two studies have proved that this blade provided better results than other commonly used blades.



Fig. 00



Fig. 0



Fig. 1



Fig. 2



Fig. 3



Fig. 3.5



Fig. 4



Fig. 5

Code	Description	Fig.	Size
01-306-00	Premature	00	68 mm
01-306-0	Neonate	0	80 mm
01-306-1	Infant	1	95 mm
01-306-2	Child	2	105 mm
01-306-3	Medium Adult	3	135 mm
01-306-35	Ext. Medium Adult	3.5	145 mm
01-306-4	Large Adult	4	155 mm
01-306-5	X-Large	5	175 mm

The Miller is one of the most popular blades. The tongue is straight with a slight upward curve near the tip. In cross-section the flange, web, and tongue form a C with the top fattened. Placing the bulb on the right side allows it to be protected by the flange. Several modifications have been described. In comparing the Macintosh and Miller blades, it was found that force head extension and cervical spine movement were less with the Miller.



Fig. 00



Fig. 2



Fig. 0



Fig. 3



Fig. 1



Fig. 4

Code	Description	Fig.	Size
01-307-00	Premature	00	65 mm
01-307-0	Neonate	0	78 mm
01-307-1	Infant	1	102 mm
01-307-2	Child	2	154 mm
01-307-3	Medium Adult	3	195 mm
01-307-4	Large Adult	4	205 mm

These blades have a flexible tip that is controlled by a lever attached to the proximal end of the blade. When the lever is pushed toward the handle, the tip of the blade is flexed. This laryngoscope may be helpful when a difficult intubation is encountered. It may be especially useful in patients with minimal neck movement. External laryngeal pressure may further improve the view. Even if the blade does not improve the view of the larynx, it may improve the likelihood of successful intubation by elevating the epiglottis.



Fig. 2



Fig. 3



Fig. 4

Code	Description	Fig.1	Size
01-308-2	Child	2	105 mm
01-308-3	Medium Adult	3	130 mm
01-308-4	Large Adult	4	155 mm

Battery Handles & Replacement Lamps for Conventional Laryngoscope  
 Batteriegriffe & Ersatzlampen für herkömmliches Laryngoskop  
 Manijas de baterías y lámparas de repuesto para laringoscopia convencional  
 Poignées de batterie et lampes de rechange pour le laryngoscope conventionnel  
 Batteria Maniglia e lampade di ricambio per laringoscopia convenzionale



Diamond knurled barrel gives strong grip to the user.  
 Conforms to all conventional blades as per ISO 7376 standard.  
 Simple change of batteries at the base of the handle.  
 Crafted from high quality chrome plated brass.  
 Economical solution for intubation as compare to green system.  
 Fully autoclavable @ 134 C for 5 minutes.



#### Battery Handles, Stainless Steel

Code	Description	Battery	Size
01-309-01	Infant	1xLithium 123 Size	110 mm
01-309-02	Stubby	2xAA Size	115 mm
01-309-03	Pediatric	2xAA Size	145 mm
01-309-04	Medium	2xC Size	150 mm

#### Battery Handles, Brass Chrome Plated

Code	Description	Battery	Size
01-310-01	Infant	1xLithium 123 Size	110 mm
01-310-02	Stubby	2xAA Size	115 mm
01-310-03	Pediatric	2xAA Size	145 mm
01-310-04	Medium	2xC Size	150 mm

#### Replacement Lamps

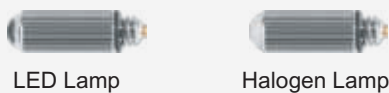

Code	Description	Type	Voltage
01-311-00	Small	Xenon	2.5 V
01-312-00	Adult	LED	3.0 V
01-313-00	Small	Halogen	2.5 V
01-314-00	Adult	Halogen	3.5 V



#### Macintosh Conventional Laryngoscope Sets, English Profile

Code	Description
01-315-01	Mac Conventional Laryngoscope Set of 4 Blades 1,2,3,4 with 1 Medium Handle, 1 Replacement Lamp, in Plastic Case.
01-315-02	Mac Conventional Laryngoscope Set of 5 Blades 0,1,2,3,4 with 1 Medium Handle, 1 Replacement Lamp, in Plastic Case.
01-315-03	Mac Conventional Laryngoscope Set of 6 Blades 00,0,1,2,3,4 with 1 Medium Handle, 1 Replacement Lamp, in Plastic Case.



#### Miller Conventional Laryngoscope Sets, English Profile

Code	Description
01-316-01	Miller Conventional Laryngoscope Sets Set of 4 Blades 1,2,3,4 with 1 Medium Handle, 1 Replacement Lamp in Plastic Case.
01-316-02	Miller Conventional Laryngoscope Sets Set of 5 Blades 0,1,2,3,4 with 1 Medium Handle, 1 Replacement Lamp, in Plastic Case.
01-316-03	Miller Conventional Laryngoscope Sets Set of 6 Blades 00,0,1,2,3,4 with 1 Medium Handle, 1 Replacement Lamp, in Plastic Case.

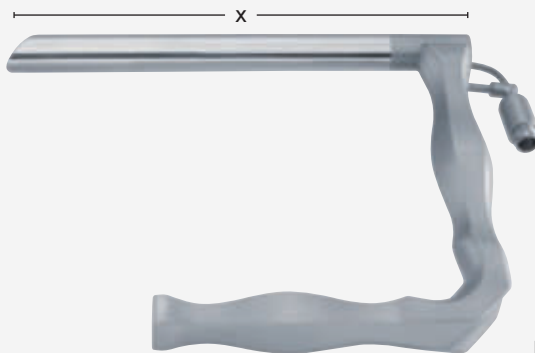

Jackson with light carrier, stainless steel  
Jackson mit Lichtträger, rostfrei  
Jackson con porta fibras, inoxidable  
Jackson avec porte de lumière, inoxydable  
Jackson con porta luce, inossidabile

Light carrier, only, for Jackson  
Lichtträger, allein, für Jackson  
Porta fibras, sola, para Jackson  
Porte de lumière, seul, pour Jackson  
Porta luce, sola, per Jackson

### Jackson

**01-188-12**

x = 12 cm  
for babys  
für Säuglinge  
para lactantes  
pour nourissons  
per lattanti

**01-188-17**

x = 17 cm  
for children  
für Kinder  
para niños  
pour enfants  
per bambini

**01-188-18**

x = 18 cm  
for adults  
für Erwachsene  
para adultos  
pour adultes  
per adulti

**01-189-12**

x = 12 cm  
for babys  
für Säuglinge  
para lactantes  
pour nourissons  
per lattanti

**01-189-17**

x = 17 cm  
for children  
für Kinder  
para niños  
pour enfants  
per bambini

**01-189-18**

x = 18 cm  
for adults  
für Erwachsene  
para adultos  
pour adultes  
per adulti



### Holinger

**01-190-17**

x = 17.1 cm

**01-190-18**

x = 18 cm

Holinger with light carrier, stainless steel  
Holinger mit Lichtträger, rostfrei  
Holinger con porta fibras, inoxidable  
Holinger avec porte de lumière, inoxydable  
Holinger con porta luce, inossidabile

**01-191-17**

x = 17.1 cm

**01-191-18**

x = 18 cm

Light carrier, only, for Holinger  
Lichtträger, allein, für Holinger  
Porta fibras, sola, para Holinger  
Porte de lumière, seul, pour Holinger  
Porta luce, solo, per Holinger





Inka  
Fig.1

01-148-01 x = 13.5 cm

Stainless steel  
Rostfreier Edelstahl  
Acero inoxidable  
Acier inoxydable  
Acciaio inossidabile

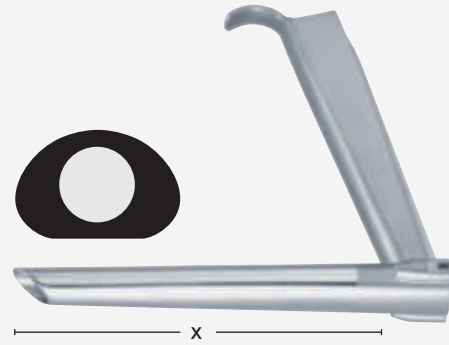

Inka  
Fig.2

01-149-02 x = 15.2 cm

Stainless steel  
Rostfreier Edelstahl  
Acero inoxidable  
Acier inoxydable  
Acciaio inossidabile



Inka  
Fig.3

01-150-03 x = 18.2 cm

Stainless steel  
Rostfreier Edelstahl  
Acero inoxidable  
Acier inoxydable  
Acciaio inossidabile



Inka  
Fig.4

01-151-04 x = 17.2 cm

Stainless steel  
Rostfreier Edelstahl  
Acero inoxidable  
Acier inoxydable  
Acciaio inossidabile

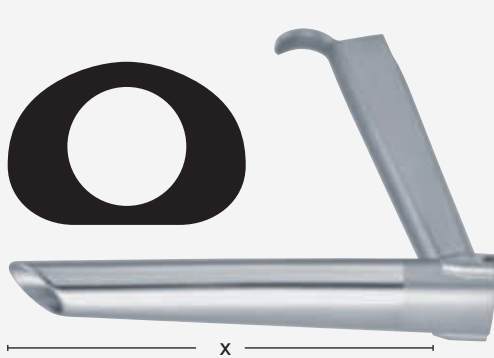

**Inka**  
 01-192-05 x = 17.2 cm

Fig.5

Stainless steel  
 Rostfreier Edelstahl  
 Acero inoxidable  
 Acier inoxydable  
 Acciaio inossidabile



**Inka**  
 01-193-06 x = 18.2 cm

Fig.6

Stainless steel  
 Rostfreier Edelstahl  
 Acero inoxidable  
 Acier inoxydable  
 Acciaio inossidabile



**Inka**  
 01-194-07 x = 22.2 cm

Fig.7

Rostfreier Edelstahl  
 Stainless steel  
 Acier inoxydable  
 Acero inoxidable  
 Acciaio inossidabile



**Jason**  
 01-195-34 34 cm - 13"

Chest-support with support-rod for adults  
 Bruststütze mit Stützstange für Erwachsene  
 Soporte de pecho con vara para adultos  
 Appui-poitrine avec tige pour adultes  
 Supporto per petto con asta per adulti



01-196-24 24 cm - 9"

Support-rod for children  
 Stützstange für Kinder  
 Vara para niños  
 Tige pour enfants  
 Asta per bambini

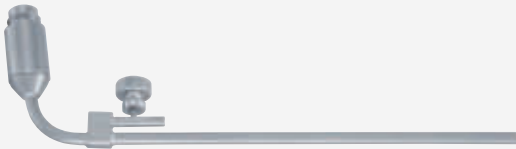

Lupus  
Fig. 1

01-197-00

for laryngoscopes  
f ur Laryngoskope  
para laringoscopios  
pour laryngoscopes  
per laringoscopi



Fig. 2

01-198-00

Suction tube for laryngoscopes  
Rauchabsaugrohr f ur Laryngoskope  
Tubo de aspiraci on para laringoscopios  
Tube d'aspiration pour laryngoscopes  
Tubo d'aspirazione per laringoscopi

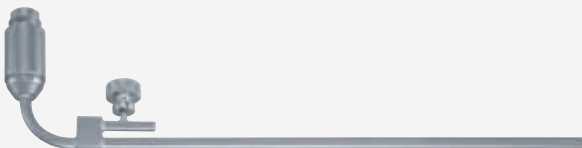

Fig. 3

01-199-00

for laryngoscopes  
f ur Laryngoskope  
para laringoscopios  
pour laryngoscopes  
per laringoscopi

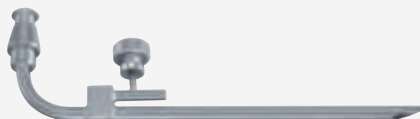

Fig.4

01-200-00

Injections drain tube for laryngoscopes  
Injektionskan ule f ur Laryngoskope  
Canula de inyecci on para laringoscopios  
Canule   injection pour laryngoscopes  
Cannula d'iniezione per laringoscopi

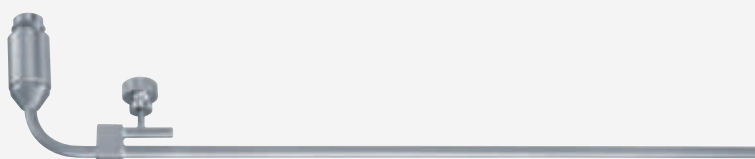

Fig. 5

01-201-00

for laryngoscope  
für Laryngoskop  
para laringoscopia  
pour laryngoscope  
per laringoscopia



Aspiration – Probes  
Aspiration – Sonden  
Aspiración – Sondas  
Aspiration – Sondes  
Aspirazione – Sonde



Universal

02-300-01

Fig. 1  
 6.0 mmØ

02-300-02

Fig. 2  
 4.5 mmØ

02-300-03

Fig. 3  
 3.0 mmØ

02-300-04

Fig. 4  
 1.75 mmØ

Set  
 Satz  
 Juego  
 Jeu  
 Serie



Uckermann

02-301-13

13 cm - 5"

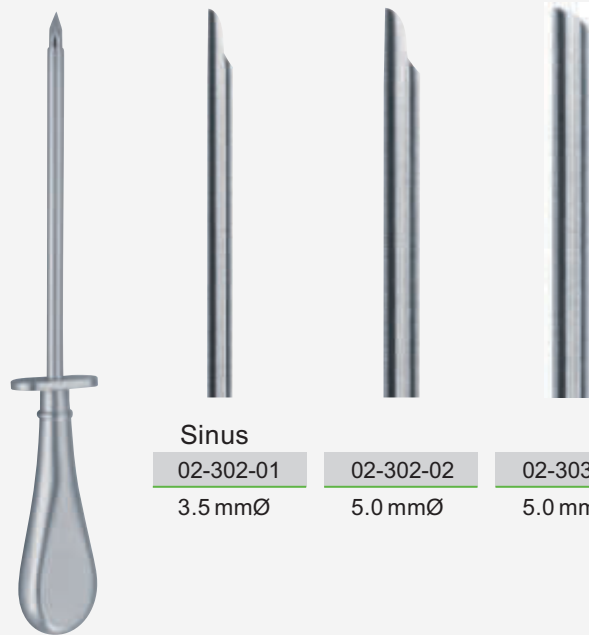

Sinus

02-302-01

3.5 mmØ

02-302-02

5.0 mmØ

02-303-03

5.0 mmØ

17 cm - 6 3/4"



**Lichtwitz**

02-304-18	02-304-20	19 cm - 7 1/2"
1.8 mmØ	2.0 mmØ	



**Ochsner**

02-305-10	3 1/3 mmØ	10 Char./Fr.
02-305-12	4 mmØ	12 Char./Fr.
02-305-14	4 2/3 mmØ	14 Char./Fr.
02-305-16	5 1/3 mmØ	16 Char./Fr.
02-305-18	6 mmØ	18 Char./Fr.
02-305-20	6 2/3 mmØ	20 Char./Fr.
02-305-22	7 1/3 mmØ	22 Char./Fr.
02-305-24	8 mmØ	24 Char./Fr.
02-305-26	8 2/3 mmØ	26 Char./Fr.
02-305-28	9 1/3 mmØ	28 Char./Fr.
	10 cm - 4"	



**Nelson**

02-306-60	02-306-83	02-306-95	02-306-11	21 cm - 8 1/4"
6.0 mmØ	8.3 mmØ	9.5 mmØ	11.6 mmØ	





**Landau**  
 02-307-16 16 cm - 6 ¼"  
 2 mmØ



**Pierce**  
 02-308-03 3 mmØ  
 02-308-04 4 mmØ  
 02-308-05 5 mmØ  
 17 cm - 6 ¾"



**Krause**  
 02-309-15 15 cm - 6"  
 5.5 mmØ



**Coakley**  
 02-310-16 16 cm - 6 ¼"  
 2.25 mmØ

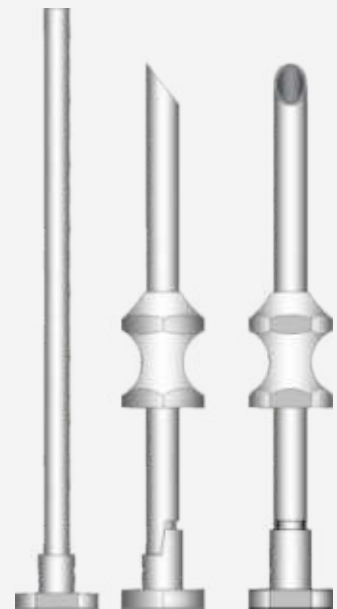

**Hormone Implant Needle Trocar**  
 02-310-01 13 cm - 5 ¼"





Cooley  
Fig. 1

02-311-35 35 cm - 13 3/4"  
8 mmØ



Fig. 2

02-312-31 31 cm - 12 1/4"  
10 mmØ



Fig. 3

02-313-30 30 cm - 12"  
6 mmØ



Fig. 4

02-314-33 33 cm - 13"  
8 mmØ



Poole  
 02-315-22 22 cm - 8" 8 mmØ  
 23 Charr./Fr.  
 Curved



Poole  
 02-316-22 22 cm - 8" 10 mmØ  
 30 Charr./Fr.  
 Straight



Andrews-Pynchon  
 02-317-23 23.5 cm - 9 1/4"



De Bakey  
 02-318-27 27.5 cm - 10 3/4"



02-319-27  
 Lower  
 Tip only

Yankauer  
 02-320-27 27 cm - 10 3/4"



**Hartmann**

02-321-01	02-321-04	2.0 mmØ
02-321-02	02-321-05	2.5 mmØ
02-321-03	02-321-06	3.0 mmØ

Fig.1

Fig.2



**Killian**

○	02-322-25	2.5 mmØ
●	02-322-30	3.0 mmØ

16 cm - 6"

oval opening  
ovale Öffnung  
apertura oval  
ouverture ovale  
apertura ovale



**Hartmann**

02-323-00	02-323-01	02-323-02	02-323-03	02-323-04	02-323-05	15 cm - 6"
-----------	-----------	-----------	-----------	-----------	-----------	------------

Fig.0

Fig.1

Fig.2

Fig.3

Fig.4

Fig.5

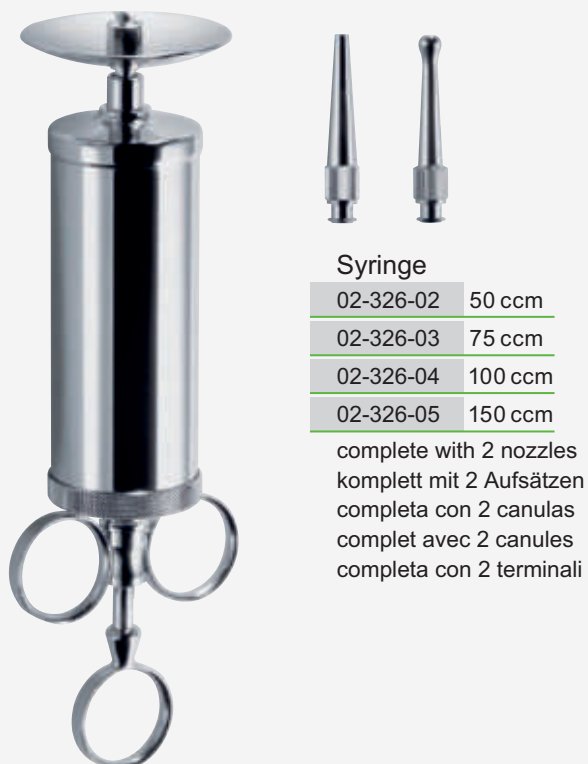
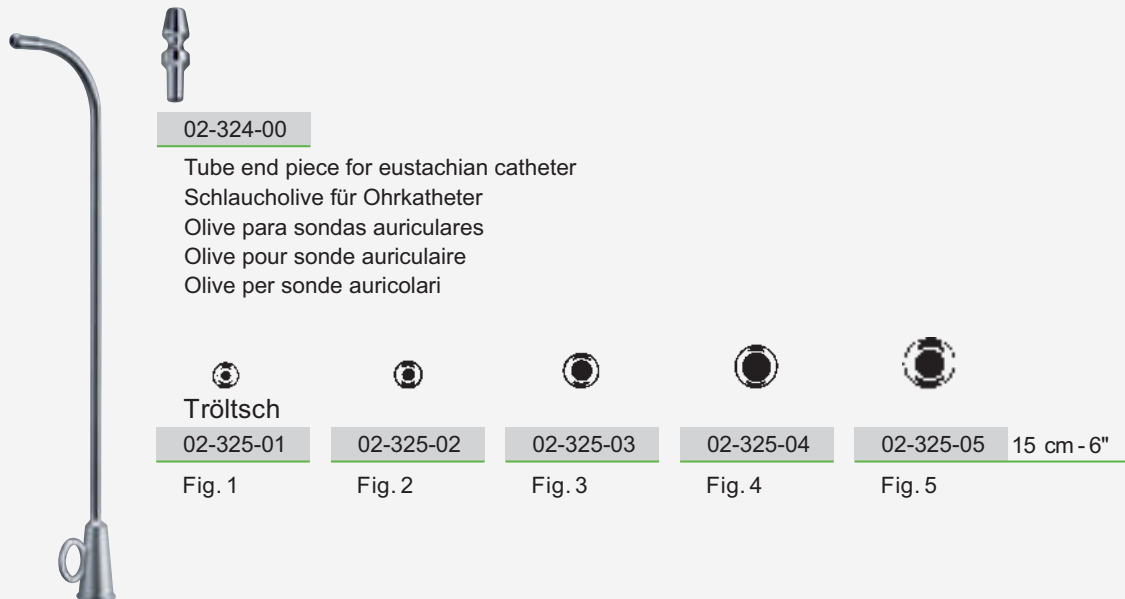

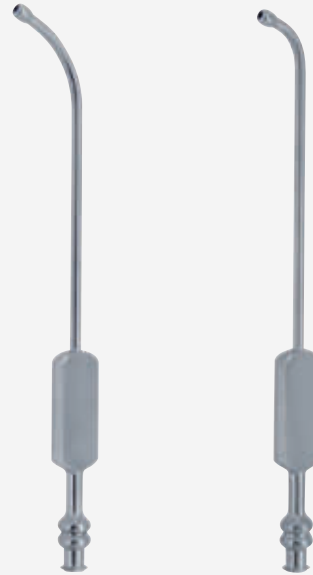

**Eicken**

02-327-01

02-327-02

slightly curved  
leicht gebogen  
ligeramente curvada  
légèrement courbé  
leggermente curva

02-327-03 2.5 mmØ

02-327-04 3.0 mmØ

strongly curved  
stark gebogen  
muy curvada  
très courbé  
fortemente curva

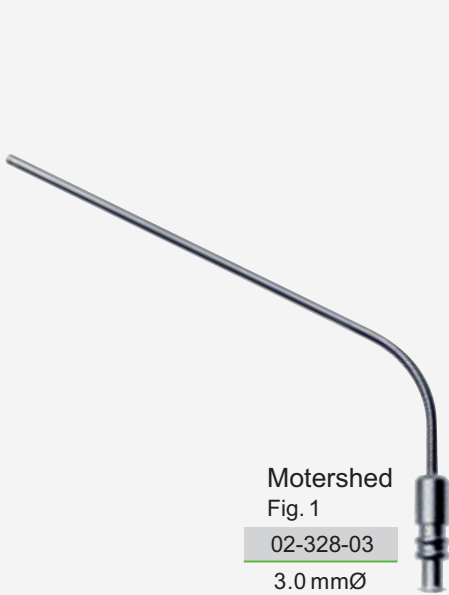

**Motershed  
Fig. 1**

02-328-03

3.0 mmØ

Luer  
Lock



**Motershed  
Fig. 2**

02-329-02

2.5 mmØ

Luer  
Lock



**Fisch**

02-330-04

4.0 mmØ



Strol  
 Fig. 1

02-331-01

straight  
 gerade  
 recta  
 droite  
 retta

Tonsil needle  
 Tonsillenkanüle  
 Aguja para amigdales  
 Aiguille pour amygdales  
 Cannule per tonsille



Fig. 2

02-331-02

curved  
 gebogen  
 curva  
 courbe  
 curva

0.8 mmØ



Fig. 3

02-332-01

bayonet  
 bajonettförmig  
 bayoneta  
 baïonette  
 baionetta

Septum needle  
 Septumkanüle  
 Aguja para el tabique nasal  
 Aiguille pour le cloison nasal  
 Ago per setto nasale

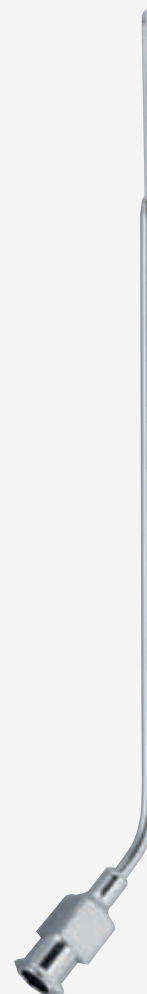
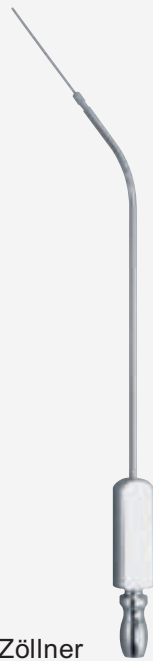

Fig. 4

02-332-02

angled on flat  
 abgewinkelt  
 angulado  
 coudé sur le plat  
 angolato

0.8 mmØ



Zöllner

02-333-07

0.7 mmØ

complete with 1 slip-on cannula, 0.7 mm Ø  
komplett mit 1 aufsetzbaren Kanüle, 0.7 mm Ø  
completo con 1 cánula desmontable de 0.7 mm Ø  
complet avec 1 canule démontable, 0.7 mm de Ø  
completa di 1 cannula applicabile di mm 0.7 di Ø

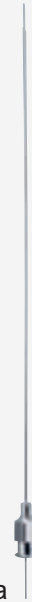

lowa

02-334-16

0.7 mmØ

16 cm - 6 ¼"



Magill

02-335-30 3.0 mmØ

02-335-35 3.5 mmØ

02-335-40 4.0 mmØ

24.5 m - 9 ¾"

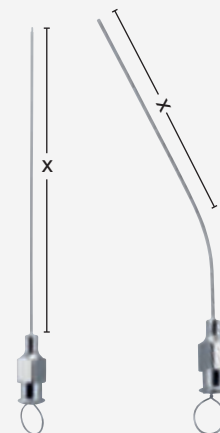

Rosen

02-336-07

02-337-07

0.7 mmØ

02-336-09

02-337-09

0.9 mmØ

02-336-12

02-337-12

1.2 mmØ

x = 80 mm

x = 65 mm



**Baron**

02-338-03	02-339-03	1 mmØ	3 Charr./Fr.
02-338-05	02-339-05	1 $\frac{2}{3}$ mmØ	5 Charr./Fr.
02-338-07	02-339-07	2 $\frac{1}{3}$ mmØ	7 Charr./Fr.
7.5 cm - 3"		10 cm - 4"	



**House**

02-340-03	02-341-03	1 mmØ	3 Charr./Fr.
02-340-05	02-341-05	1 $\frac{2}{3}$ mmØ	5 Charr./Fr.
02-340-07	02-341-07	2 $\frac{1}{3}$ mmØ	7 Charr./Fr.
02-340-08	02-341-08	2 $\frac{2}{3}$ mmØ	8 Charr./Fr.
02-340-10	02-341-10	3 $\frac{1}{3}$ mmØ	10 Charr./Fr.
02-340-12	02-341-12	4 mmØ	12 Charr./Fr.
02-340-14	02-341-14	4 $\frac{2}{3}$ mmØ	14 Charr./Fr.
7.5 cm - 3"		10 cm - 4"	



**Fergusson**

02-342-06	2 mmØ	6 Charr./Fr.
02-342-07	2 $\frac{1}{3}$ mmØ	7 Charr./Fr.
02-342-08	2 $\frac{2}{3}$ mmØ	8 Charr./Fr.
02-342-09	3 mmØ	9 Charr./Fr.
02-342-10	3 $\frac{1}{3}$ mmØ	10 Charr./Fr.
02-342-12	4 mmØ	12 Charr./Fr.
02-342-15	5 mmØ	15 Charr./Fr.
17 cm - 6 $\frac{3}{4}$ "		





**Plester**

02-343-06	2 mmØ	6 Charr./Fr.
02-343-07	2½ mmØ	7 Charr./Fr.
02-343-08	2¾ mmØ	8 Charr./Fr.
02-343-09	3 mmØ	9 Charr./Fr.
02-343-10	3½ mmØ	10 Charr./Fr.
02-343-12	4 mmØ	12 Charr./Fr.
02-343-15	5 mmØ	15 Charr./Fr.

17 cm - 6¾"



**Frazier**

02-344-06	2 mmØ	6 Charr./Fr.
02-344-07	2½ mmØ	7 Charr./Fr.
02-344-08	2¾ mmØ	8 Charr./Fr.
02-344-09	3 mmØ	9 Charr./Fr.
02-344-10	3½ mmØ	10 Charr./Fr.
02-344-12	4 mmØ	12 Charr./Fr.
02-344-15	5 mmØ	15 Charr./Fr.

17 cm - 6¾"



**Adson**

02-345-12	4 mmØ	12 Charr./Fr.
02-345-15	5 mmØ	15 Charr./Fr.

21 cm - 8¼"



**Elena**

02-346-20

20 cm - 8"

Suction raspatorium – malleable, sharp  
Saug-Raspatorium – biegsam, scharf  
Legra aspiradora – maleable y agudo  
Rugine aspirante – flexible, tranchant  
Elevatore-aspiratore – flessibile, tagliente

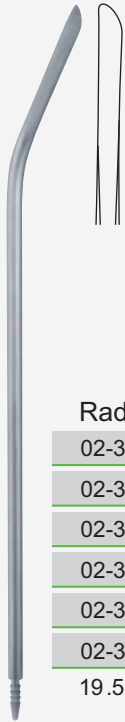

**Radon**

02-347-08	2 2/3 mmØ	8 Charr./Fr.
02-347-10	3 1/3 mmØ	10 Charr./Fr.
02-347-12	4 mmØ	12 Charr./Fr.
02-347-14	4 2/3 mmØ	14 Charr./Fr.
02-347-16	5 1/3 mmØ	16 Charr./Fr.
02-347-18	6 mmØ	18 Charr./Fr.

19.5 cm - 5 3/4"

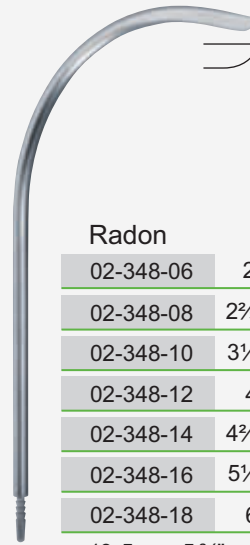

**Radon**

02-348-06	2 mmØ	6 Charr./Fr.
02-348-08	2 2/3 mmØ	8 Charr./Fr.
02-348-10	3 1/3 mmØ	10 Charr./Fr.
02-348-12	4 mmØ	12 Charr./Fr.
02-348-14	4 2/3 mmØ	14 Charr./Fr.
02-348-16	5 1/3 mmØ	16 Charr./Fr.
02-348-18	6 mmØ	18 Charr./Fr.

19.5 cm - 5 3/4"

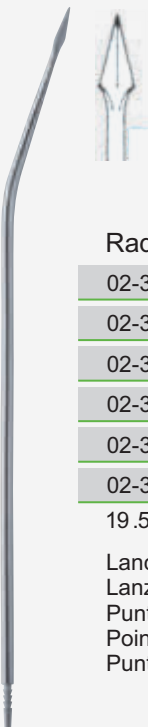

**Radon Modified**

02-349-08	2 2/3 mmØ	8 Charr./Fr.
02-349-10	3 1/3 mmØ	10 Charr./Fr.
02-349-12	4 mmØ	12 Charr./Fr.
02-349-14	4 2/3 mmØ	14 Charr./Fr.
02-349-16	5 1/3 mmØ	16 Charr./Fr.
02-349-18	6 mmØ	18 Charr./Fr.

19.5 cm - 5 3/4"

Lancet tip  
 Lanzettenspitze  
 Punta lanceolada  
 Pointe lancéolaire  
 Punta lanceolata



Pravaz (Luer-Lock)

02-350-01	Fig.1	0.90 x 38 mm Ø
02-350-02	Fig.2	0.80 x 32 mm Ø
02-350-12	Fig.12	0.70 x 32 mm Ø
02-350-14	Fig.14	0.65 x 28 mm Ø
02-350-16	Fig.16	0.60 x 25 mm Ø
02-350-18	Fig.18	0.50 x 23 mm Ø
02-350-20	Fig.20	0.45 x 20 mm Ø



Package of 12 pieces  
Packung à 12 Stück  
Paquete de 12 piezas  
Paquet de 12 pièces  
Confezione da 12 pezzi



Quinke

02-351-01	1.20 x 76.0 mm Ø
02-351-02	1.20 x 89.0 mm Ø
02-351-03	1.00 x 76.0 mm Ø
02-351-04	1.00 x 89.0 mm Ø
02-351-05	0.70 x 76.0 mm Ø
02-351-06	0.70 x 50.0 mm Ø
02-351-07	0.70 x 89.0 mm Ø



Tuohy

02-352-01	1.20 x 76.0 mm Ø
02-352-02	1.40 x 76.0 mm Ø
02-352-03	1.60 x 76.0 mm Ø



Bier

02-353-01	1.20 x 80.0 mm Ø
02-353-02	1.20 x 90.0 mm Ø



Klima-Rosegger

02-354-00	1.80 x 35.0 mm Ø
-----------	------------------



Verres

02-355-01	2.00 x 100 mm Ø
02-355-02	2.00 x 120 mm Ø
02-355-03	2.00 x 150 mm Ø



Menghini

02-356-01	1.00 x 35.0 mm Ø
02-356-02	1.00 x 70.0 mm Ø
02-356-03	1.20 x 70.0 mm Ø
02-356-04	1.20 x 100.0 mm Ø
02-356-05	1.40 x 70.0 mm Ø
02-356-06	1.40 x 100.0 mm Ø
02-356-07	1.60 x 70.0 mm Ø
02-356-08	1.80 x 100.0 mm Ø



Menghini

02-357-01	1.40 x 168.0 mm Ø
02-357-02	1.80 x 168.0 mm Ø

Connecting pieces and stopcocks  
Verbindungsstücke und Hähne  
Piezas de conexion y llaves  
Raccords et robinets  
Raccordi e rubinetti



Connector  
Fig. 1  
02-358-00



Fig. 2  
02-359-00



Franklin-Silverman  
 Mod. Fuchs

	⊘	⊕
02-360-01	2.00 x 105.0 mm Ø	1.50 x 155.0 mm Ø
02-360-02	2.00 x 130.0 mm Ø	1.50 x 180.0 mm Ø

For kidney biopsy, incl. guide needle  
 Zur perkutanen Nierenbiopsie, einschl. Suchnadel  
 Para la biopsia de los riñones, con aguja de guía  
 Pour la biopsie des reins, aiguille d'introduction incl.  
 Per la biopsia renale, con ago guida

⊘ = Outer diameter  
 Außendurchmesser  
 Diametro esterno  
 Diamètre externe  
 Diametro esterno

⊕ = Inner diameter  
 Innendurchmesser  
 Diametro interno  
 Diamètre interne  
 Diametro interno



#### Franklin-Silverman

02-361-01	02-361-03	2.00 x 105.0 mm Ø	1.50 x 155.0 mm Ø
02-361-02	02-361-04	2.50 x 145.0 mm Ø	1.50 x 180.0 mm Ø

without barb ohne Widerhaken sin garfio sans crochet senza gancio	barbed mit Widerhaken con garfio avec crochet con gancio	For liver and kidney biopsy Zur Leber- und Nierenbiopsie Para la biopsia de los riñones y del hígado Pour la biopsie des reins et de la foie Per la biopsia renale ed epatica
---	--	---

02-362-01	02-362-03	2.00 x 100.0 mm Ø	1.50 x 150.0 mm Ø
02-362-02	02-362-04	2.50 x 145.0 mm Ø	1.50 x 195.0 mm Ø

Biopsy needle, only  
Kanüle, allein  
Aguja para biopsia, sola  
Aiguille pour biopsie, seul  
Ago per biopsia, solo



**Luer**

02-363-01	02-364-01	1 ml
02-363-02	02-364-02	2 ml
02-363-05	02-364-05	5 ml
02-363-10	02-364-10	10 ml
02-363-20	02-364-20	20 ml
02-363-50	02-364-50	50 ml

Syringe, complete Barrel  
 Spritze, komplett Zylinder  
 Jeringa, completa Cilindro  
 Seringue, complète Cylindre  
 Siringa, completa Cilindro



**Luer-Lock**

02-365-01	02-366-01	1 ml
02-365-02	02-366-02	2 ml
02-365-05	02-366-05	5 ml
02-365-10	02-366-10	10 ml
02-365-20	02-366-20	20 ml
02-365-50	02-366-50	50 ml

Syringe, complete Barrel  
 Spritze, komplett Zylinder  
 Jeringa, completa Cilindro  
 Seringue, complète Cylindre  
 Siringa, completa Cilindro



**Luer-Lock**

02-367-01	02-368-01	1 ml
02-367-02	02-368-02	2 ml
02-367-05	02-368-05	5 ml

Syringe, complete Barrel  
 Spritze, komplett Zylinder  
 Jeringa, completa Cilindro  
 Seringue, complète Cylindre  
 Siringa, completa Cilindro

**02-369-00**

Luer Lock attachment  
 Luer Lock Anschluß  
 Conector Luer Lock  
 Raccord Luer Lock  
 Raccordo Luer Lock



**Janet**

02-370-50	02-371-50	50 ml
02-370-75	02-371-75	75 ml
02-370-100	02-371-100	100 ml
02-370-150	02-371-150	150 ml
02-370-200	02-371-200	200 ml

Syringe, complete Barrel  
 Spritze, komplett Zylinder  
 Jeringa, completa Cilindro  
 Seringue, complète Cylindre  
 Siringa, completa Cilindro



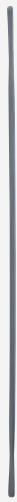

Probe			
02-372-11	02-373-11	02-374-11	11.5 cm - 4 1/2"
02-372-13	02-373-13	02-374-13	13 cm - 5"
02-372-14	02-373-14	02-374-14	14.5 cm - 5 3/4"
02-372-16	02-373-16	02-374-16	16 cm - 6 1/4"
02-372-18	02-373-18	02-374-18	18 cm - 7"
02-372-20	02-373-20	02-374-20	20 cm - 8"
02-372-25	02-373-25	02-374-25	25 cm - 9 3/4"
2.0 mmØ	1.5 mmØ	1.0 mmØ	



Probe with Eye	
02-375-11	11.5 cm - 4 1/2"
02-375-13	13 cm - 5"
02-375-14	14.5 cm - 5 3/4"
02-375-16	16 cm - 6 1/4"
02-375-18	18 cm - 7"
02-375-20	20 cm - 8"
02-375-25	25 cm - 9 3/4"

2 mmØ  
with eyelet  
mit Öhr  
con ojo  
avec oeil  
con cruna



Concave	
02-376-11	11.5 cm - 4 1/2"
02-376-13	13 cm - 5"
02-376-14	14.5 cm - 5 3/4"
02-376-16	16 cm - 6 1/4"

2 mmØ  
myrtle-shaped  
Myrtenblattsonde  
en forme de mirto  
en forme de myrte  
forma di mirto



**Butterfly**  
Fig. 1

02-377-11	11.5 cm - 4 1/2"
02-377-13	13 cm - 5"
02-377-14	14.5 cm - 5 3/4"
02-377-16	16 cm - 6 1/4"
02-377-18	18 cm - 7"
02-377-20	20 cm - 8"



**Butterfly**  
Fig. 2

02-378-11	11.5 cm - 4 1/2"
02-378-13	13 cm - 5"
02-378-14	14.5 cm - 5 3/4"
02-378-16	16 cm - 6 1/4"
02-378-18	18 cm - 7"
02-378-20	20 cm - 8"

With pointed end



**Doyen**  
02-379-14  
14 cm - 5 1/2"



**Nelaton**  
02-380-16  
16 cm - 6 1/2"



Farrell-Lathbury

02-381-12	02-382-12	02-383-12	12 cm - 4 3/4"	0.9 mm Ø
02-381-14	02-382-14	02-383-14	14 cm - 5 1/2"	0.9 mm Ø
02-381-16	02-382-16	02-383-16	16.5 cm - 6 1/4"	1.1 mm Ø
02-381-18	02-382-18	02-383-18	18 cm - 7"	1.2 mm Ø
02-381-23	02-382-23	02-383-23	23 cm - 9"	1.3 mm Ø



Saleh

02-387-28	02-388-28	28 cm - 11"
2.5 mm Ø	2.5 mm Ø	

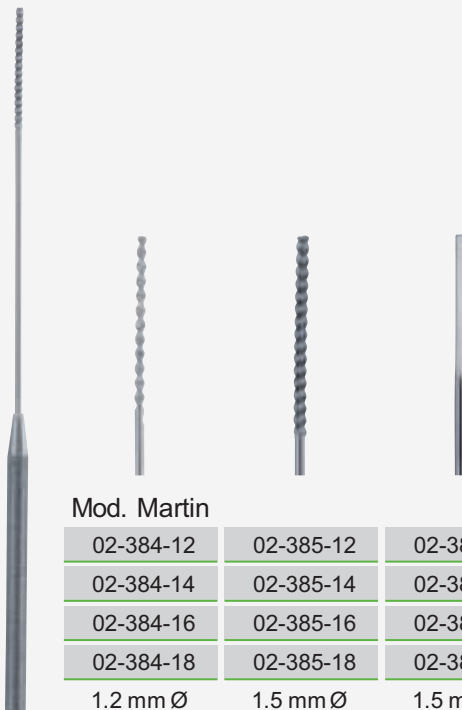

Mod. Martin

02-384-12	02-385-12	02-386-12	12 cm - 4 3/4"
02-384-14	02-385-14	02-386-14	14 cm - 5 1/2"
02-384-16	02-385-16	02-386-16	16.5 cm - 6 1/4"
02-384-18	02-385-18	02-386-18	18 cm - 7"
1.2 mm Ø	1.5 mm Ø	1.5 mm Ø	





Pelteson

02-391-23

23 cm - 9"



Scalpels – Knives  
Skalpelle – Messer  
Bisturís – Cuchillos  
Scalpels – Couteaux  
Bisturi – Coltelli



**Dieffenbach**  
 03-500-01  
 16m - 6 1/2"  
 Fig. 1



03-500-02  
 16 cm - 6 1/2"  
 Fig. 2



**Dissecting**  
 03-501-01  
 Fig. 1



03-501-02  
 Fig. 2



03-501-03  
 Fig. 3



03-501-04  
 Fig. 4



03-501-05  
 Fig. 5



03-501-06  
 Fig. 6



03-501-07  
 Fig. 7



03-501-08  
 Fig. 8



03-501-09  
 Fig. 9



03-501-10  
 Fig. 10

**!** For blades Fig. 18 –25  
Für Klingen Fig. 18 –25  
Para hojas Fig. 18–25  
Pour lames Fig. 18 –25  
Per lame Fig. 18 –25



03-505-03  
Fig. 3



03-509-03  
Fig. 3  
graduated



03-502-04  
Fig. 4



03-506-01  
Fig. 3 L

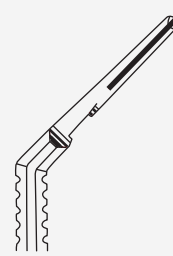

03-506-02  
Fig. 3 L  
abgewinkelt  
angled on flat  
coudé sur le plat  
angulado  
angolato



03-503-01  
Fig. 4 L

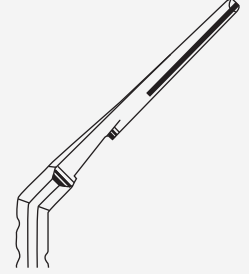

03-503-02  
Fig. 4 L  
angled on flat  
abgewinkelt  
angulado  
coudé sur le plat  
angolato

! For blades Fig. 10 – 15  
Für Klängen Fig. 10 – 15  
Para hojas Fig. 10–15  
Pour lames Fig. 10 – 15  
Per lame Fig. 10 – 15



03-507-07  
Fig. 7K

03-508-07  
Fig. 7

03-510-03  
Fig. 3 R

03-511-03  
Fig. 3 RG

Collin  
03-504-08  
Fig.8  
hollow  
hohl  
hueco  
creux  
cavo





Package of 100 pieces  
Packung mit 100 Stück  
Paquet de 100 pièces  
Paquetes de 100 piezas  
Confezione da 100 pezzi



03-512-10  
Fig. 10



03-512-11  
Fig. 11



03-512-12  
Fig. 12



03-512-12D  
Fig. 12d



03-512-15  
Fig. 15



03-512-12C  
Fig. 15c

double cutting edge  
doppelschneidend  
corta doble  
double tranchante  
a doppio taglio

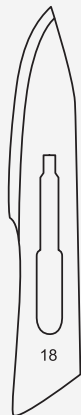

03-512-18  
Fig. 18



03-512-20  
Fig. 20



03-512-21  
Fig. 21

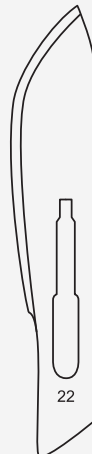

03-512-22  
Fig. 22



03-512-23  
Fig. 23

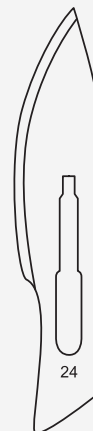

03-512-24  
Fig. 24

Micro-blade holder – Micro-blades  
 Mikro-Klingenhalter – Mikro-Klingen  
 Porta para micro-hojas – Micro-hojas  
 Porte micro-lames – Micro-lames  
 Porta micro-lame – Micro-lame

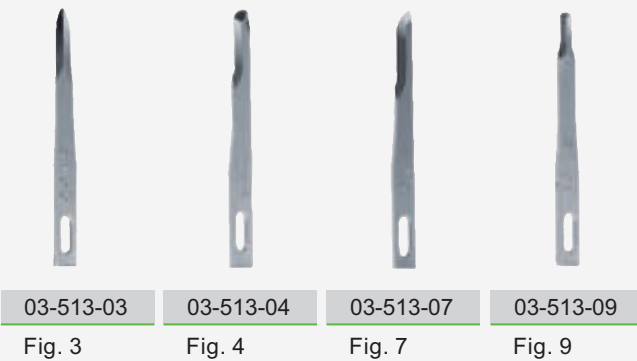

03-513-03 Fig. 3    03-513-04 Fig. 4    03-513-07 Fig. 7    03-513-09 Fig. 9

Micro-blades – package of 25 pieces  
 Mikro-Klingen – Packung mit 25 Stück  
 Micro-hojas – paquete de 25 piezas  
 Micro-lames – paquet de 25 pièces  
 Micro-lame – confezione da 25 pezzi

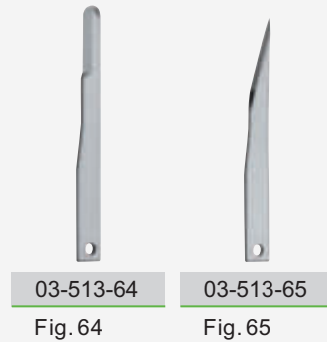

03-513-64 Fig. 64    03-513-65 Fig. 65



03-513-67 Fig. 67    03-513-69 Fig. 69



Package of 10 pieces  
 Packung mit 10 Stück  
 Paquet de 10 pièces  
 Paquetes de 10 piezas  
 Confezione da 10 pezzi

**Tinos**

03-513-13

13.5 cm - 5 1/4"

Titanium  
 Titan  
 Titaneo  
 Titan  
 Titanio



**Manuel**  
 03-514-13

13.5 cm - 5 1/4"  
 Changeable blades



**Caspar**  
 03-515-15

15.5 cm - 6"  
 Fig. 1



03-516-18

18 cm - 7"  
 Fig. 2



03-517-20

20 cm - 8"  
 Fig. 3



**Landolt**

03-518-21 21 cm - 8 1/4"  
 03-518-25 25 cm - 10"



**Castroviejo**  
03-519-13  
13 cm - 5"



**Troutman-  
Chris**  
03-520-09  
9 cm - 3 1/2"



03-521-09  
9 cm - 3 1/2"



**Hardy**  
Fig. 1  
03-522-24  
24 cm - 9 1/2"  
for horizontal  
cuts



**Fig. 2**  
03-523-24  
24 cm - 9 1/2"  
for vertical cuts



Troutman-Chris

03-524-09

9 cm - 3 1/2"  
 straight  
 Ø 5,5 mm

03-525-09

9 cm - 3 1/2"  
 angled  
 Ø 5,5 mm



Castroviejo

03-526-12

12 cm - 4 3/4"  
 Swiss pattern  
 Jaw inside  
 smooth



Troutman Modified

03-527-13

13 cm - 5"

Jaw inside:  
 concave/convex



Kugai

03-528-18

18.5 cm - 7 1/4"



03-529-00

Razor Blades



Package of 10 pieces  
 Packung mit 10 Stück  
 Paquet de 10 pièces  
 Paquetes de 10 piezas  
 Confezione da 10 pezzi

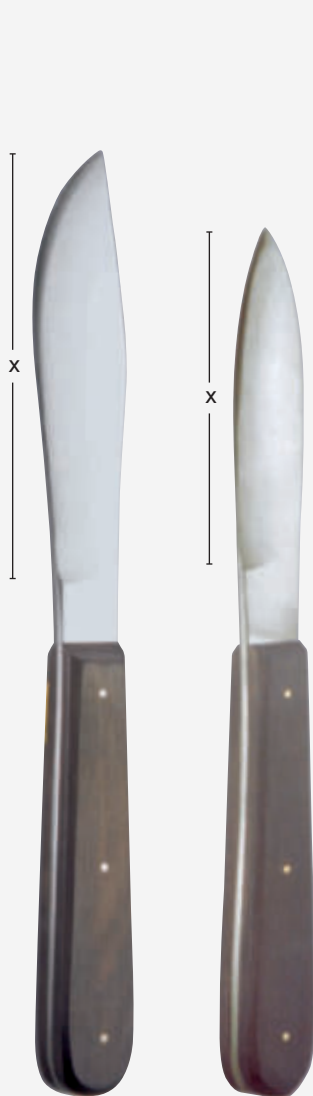

**Virchow**

03-530-25	03-531-25	25.5 cm - 10"
x = 12 cm - 4"	x = 8 cm - 3 1/2"	

Autopsy knives with wooden handle  
Seziermesser mit Holzheft  
Cuchillos para autopsia con mango de madera  
Couteaux à autopsie avec manche en bois  
Coltelli per autopsia con manico di legno



**Walb**

03-532-26	26 cm - 10 1/4"	x = 11 cm - 4 1/4"
03-532-29	29 cm - 11 1/2"	x = 14 cm - 5 1/2"
03-532-31	31 cm - 12 1/4"	x = 17 cm - 6 3/4"

Post mortem knives with wooden handle  
Organmesser mit Holzheft  
Cuchillos para organos, con mango de madera  
Couteaux à organs avec manche en bois  
Coltelli per organi, con manico di legno



**Virchow**

03-533-26	26 cm - 10 1/4"	x = 16 cm - 6 1/4"
03-533-33	33.5 cm - 13 1/4"	x = 20 cm - 8"
03-533-38	38 cm - 15"	x = 24 cm - 9 1/2"

Brain knives with metal handle  
Hirnmesser mit Metallheft  
Cuchillos para el cerebro, con mango metálico  
Couteaux pour le cerveau, avec manche en métal  
Coltelli per cervello, con manico di metallo

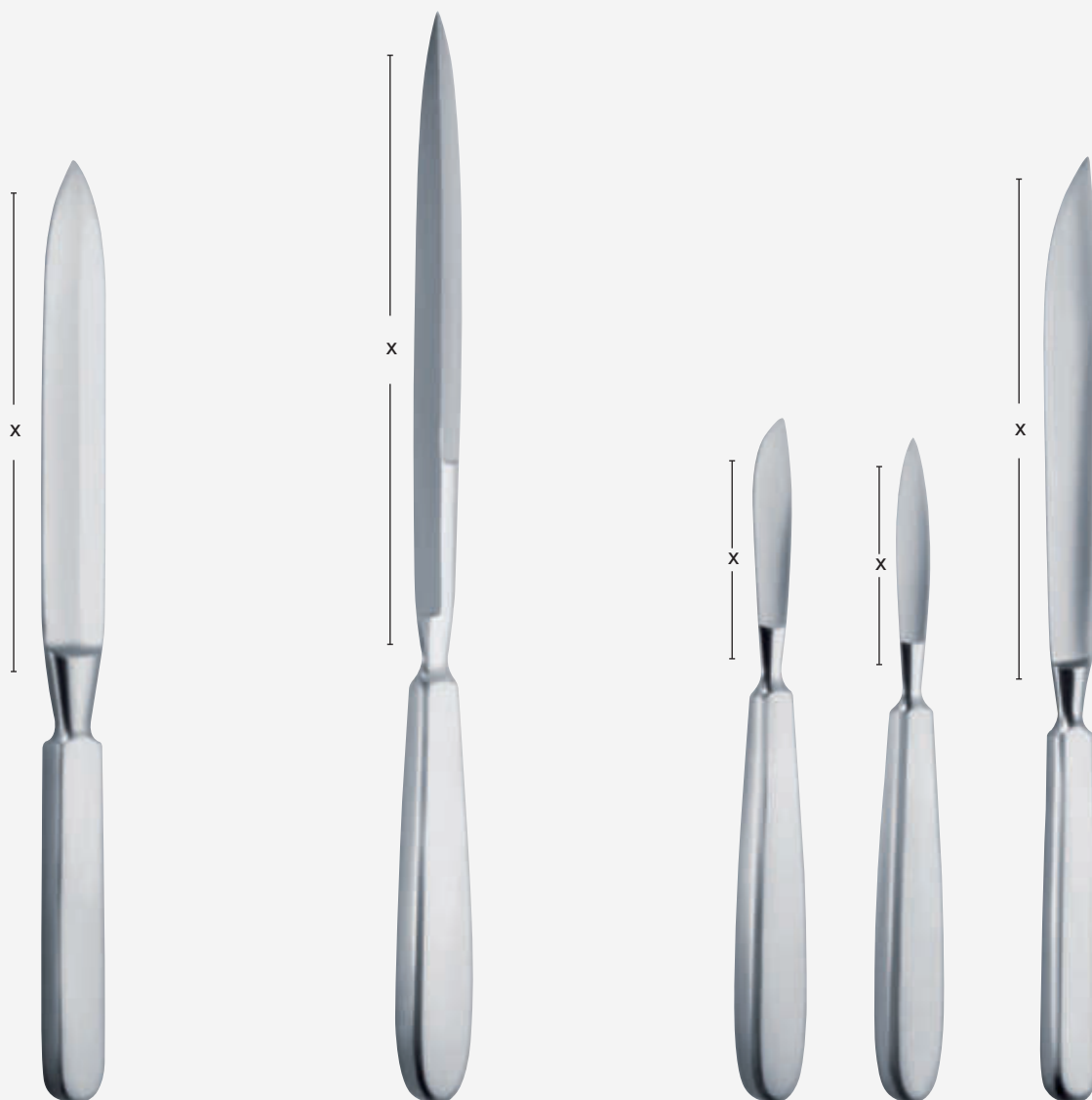

**Collin**  
 Fig. 1

03-534-13	x = 13 cm
03-534-16	x = 16 cm
03-534-19	x = 19 cm
03-534-22	x = 22 cm

double cutting edge  
 doppelschneidend  
 corta doble  
 double tranchant  
 a doppio taglio

**Catlin**  
 Fig. 2

03-535-29	29 cm - 11 1/2"
-----------	-----------------

x = 16 cm  
 double cutting edge  
 doppelschneidend  
 corta doble  
 double tranchant  
 a doppio taglio

**Langenbeck**  
 Fig. 1

03-536-05	x = 5.5 cm
-----------	------------

Fig. 2

03-537-05	x = 5.5 cm
-----------	------------

Fig. 3

03-538-12	x = 12 cm
-----------	-----------



**Thiersch**  
03-540-20  
20 cm - 8"



**Schink**  
03-541-30  
30 cm - 12"



**Blade**  
03-542-01

Spare blade  
Klinge  
Hoja de cambio  
Lame de rechange  
Lama di ricambio



**Plate**  
03-543-02

Skin fixing plate  
Spannplatte  
Placa para extender la piel  
Plaque pour tendre la peau  
Placca per stendere la pelle

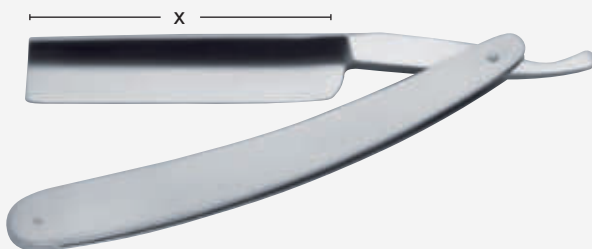

03-539-08

x = 8 cm  
Sharp  
Razor knife  
Rasiermesser  
Navaja de afeitar  
Rasoir  
Rasoio a mano libera

Complete with 1 blade and 2 plates  
Komplett mit 1 Klinge und 2 Spannhaltern  
Completo con 1 hoja y 2 placas  
Complet avec 1 lame et 2 plaques  
Completo con 1 lama e 2 placche

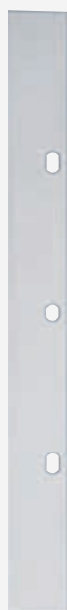

Blade

03-544-00

spare blade  
 Ersatzklinge  
 hoja de cambio  
 lame de rechange  
 lama di ricambio

package of 10 pieces  
 Packung mit 10 Stück  
 paquete de 10 piezas  
 paquet de 10 pièces  
 confezione da 10 pezzi



Humby

03-545-31

31cm - 12 ¼"

complete with 1 blade  
 komplett mit 1 Klinge  
 completo con 1 hoja  
 complet avec 1 lame  
 completo con 1 lama

Watson

03-546-30

30 cm - 12 "

complete with 1 blade, fixed bar  
 komplett mit 1 Klinge, Stange starr  
 completo con 1 hoja, barra fijada  
 complet avec 1 lame, tige fix  
 completo con 1 lama, barra fissa

Watson - Modified

03-548-30

30 cm - 12"

complete with 1 blade, fixed bar  
 komplett mit 1 Klinge, Stange starr  
 completo con 1 hoja, barra fijada  
 complet avec 1 lame, tige fix  
 completo con 1 lama, barra fissa

Silver

03-547-19

19 cm - 7 ½"





Scissors  
Schere  
Tijeras  
Ciseaux  
Forbici

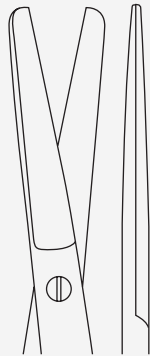

Standard

04-180-10
04-180-11
04-180-13
04-180-14
04-180-15
04-180-16
04-180-17
04-180-18
04-180-20



04-181-10
04-181-11
04-181-13
04-181-14
04-181-15
04-181-16
04-181-17
04-181-18
04-181-20



04-182-10	10.5 cm - 4 1/4"
04-182-11	11.5 cm - 4 1/2"
04-182-13	13 cm - 5"
04-182-14	14.5 cm - 5 1/4"
04-182-15	15 cm - 6"
04-182-16	16.5 cm - 6 1/2"
04-182-17	17.5 cm - 7"
04-182-18	18.5 cm - 7 1/4"
04-182-20	20 cm - 8"

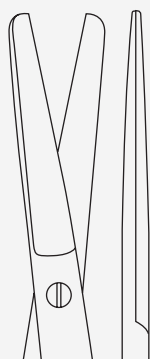

Standard

04-183-14T
04-183-16T
04-186-14S
04-186-13S



04-184-14T
04-184-16T
04-187-14S
04-187-13S



04-185-14T	14.5 cm - 5 3/4"
04-185-16T	16.5 cm - 6 1/2"
04-188-14S	14.5 cm - 5 3/4"
04-188-13S	13 cm - 5"



Standard

04-189-11
04-189-13
04-189-14
04-189-15
04-189-16
04-189-17
04-189-18
04-189-20



04-190-11
04-190-13
04-190-14
04-190-15
04-190-16
04-190-17
04-190-18
04-190-20



04-191-11	11.5 cm - 4 ½"
04-191-13	13 cm - 5"
04-191-14	14.5 cm - 5 ¼"
04-191-15	15 cm - 6"
04-191-16	16.5 cm - 6 ½"
04-191-17	17.5 cm - 7"
04-191-18	18.5 cm - 7 ¼"
04-191-20	20 cm - 8"



Standard

04-192-14T
04-192-16T
04-195-14S

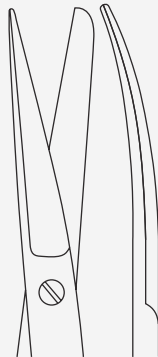

04-193-14T
04-193-16T
04-196-14S



04-194-14T	14.5 cm - 5 ¾"
04-194-16T	16.5 cm - 6 ½"
04-194-16S	14.5 cm - 5 ¾"



Grazil

04-197-13
04-197-14
04-197-13T
04-197-13S



04-198-13
04-198-14
04-198-13T
04-198-13S



04-199-13	13 cm - 5"
04-199-14	14.5 cm - 5 3/4"
04-199-13T	14.5 cm - 5 3/4"
04-199-13S	14.5 cm - 5 3/4"



Grazil

04-200-13
04-200-14
04-200-14T
04-200-14S



04-201-13
04-201-14
04-201-14T
04-201-14S



04-202-13	13 cm - 5"
04-202-14	14.5 cm - 5 3/4"
04-202-14T	14.5 cm - 5 3/4"
04-202-14S	14.5 cm - 5 3/4"



**Deaver**

04-203-14

straight  
gerade  
recta  
droits



04-204-14

curved  
gebogen  
curva  
courbes



04-205-14

straight, saw edge  
gerade, gezahnt  
recta, dentada  
droits, dentelés



04-206-14

curved, saw edge  
gebogen, gezahnt  
curva, dentada  
courbes, dentelés

14 cm - 5 1/2"



**Mixer**

04-207-15

straight  
gerade  
recta  
droits



04-208-15

curved  
gebogen  
curva  
courbes



04-209-15

straight, saw edge  
gerade, gezahnt  
recta, dentada  
droits, dentelés



04-210-15

curved, saw edge  
gebogen, gezahnt  
curva, dentada  
courbes, dentelés

15.5 cm - 6 1/8"

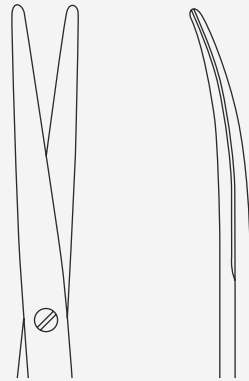

**Lexer**

04-211-16	04-212-16
16 cm - 6 1/4"	16 cm - 6 1/4"
04-211-21	04-212-21
21 cm - 8 1/4"	21 cm - 8 1/4"

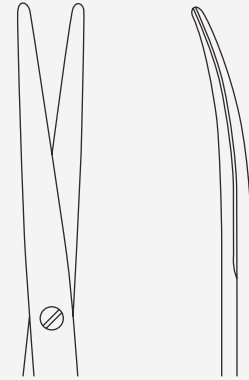

**Lexer**

04-213-16T	04-214-16T
16.5 cm - 6 1/2"	16.5 cm - 6 1/2"
04-213-21T	04-214-21T
21 cm - 8 1/4"	21 cm - 8 1/4"
04-215-16S	04-216-16S
16.5 cm - 6 1/2"	16.5 cm - 6 1/2"
04-215-21S	04-216-21S
21 cm - 8 1/4"	21 cm - 8 1/4"

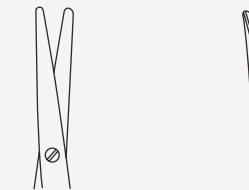

**Lexer-Baby**

04-217-10

straight  
 gerade  
 recta  
 droits



04-218-10

curved  
 gebogen  
 curva  
 courbes



04-219-10

straight, saw edge  
 gerade, gezahnt  
 recta, dentada  
 droits, dentelés



04-220-10

curved, saw edge  
 gebogen, gezahnt  
 curva, dentada  
 courbes, dentelés

10 cm / 4"

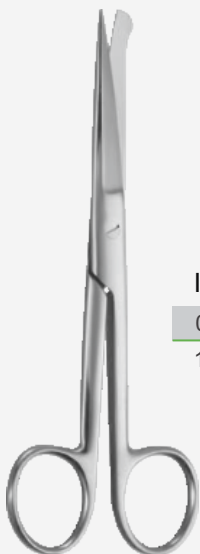

**Incision**

04-221-13  
 13 cm - 5"



04-221-14  
 14.5 cm - 5 1/4"



04-221-16  
 16.5 cm - 6 1/2"



**Incision - Modified**

04-222-16  
 16.5 cm - 6 1/2"



Fergusson

04-223-14

14 cm - 5 1/2"

04-223-16

16.5 cm - 6 1/2"

04-223-18

18 cm - 7"



Richter

04-224-14

14 cm - 5 1/2"



Lawson Tait

04-225-12

12.5 cm - 5"

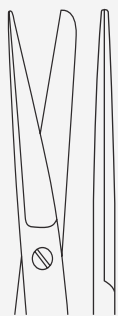

Lange

04-226-14

straight  
gerade  
recta  
droits



04-227-14

curved  
gebogen  
curva  
courbes



04-228-14

straight, saw edge  
gerade, gezahnt  
recta, dentada  
droits, dentelés



04-229-14

curved, saw edge  
gebogen, gezahnt  
curva, dentada  
courbes, dentelés

14.5 cm - 5 3/4"

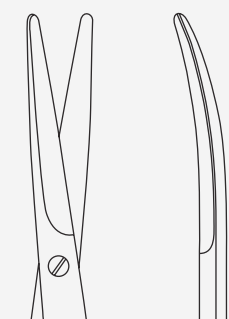
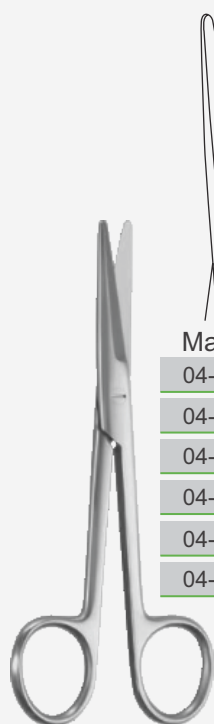

**Mayo**

04-230-14	04-231-14	14 cm - 5 1/2"
04-230-15	04-231-15	15 cm - 6"
04-230-17	04-231-17	17 cm - 6 3/4"
04-230-20	04-231-20	20 cm - 8"
04-230-23	04-231-23	23 cm - 9"
04-230-28	04-231-28	28 cm - 11"

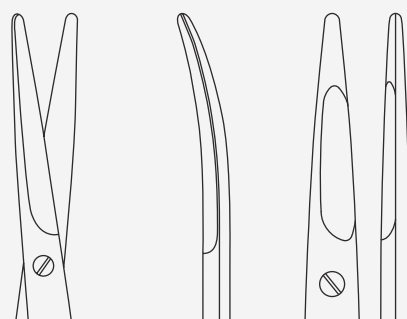

**Mayo-Style**

04-232-15	04-233-15	04-233-15B	15 cm - 6"
04-232-17	04-233-17	04-233-17B	17 cm - 6 3/4"
04-232-19	04-233-19	04-233-19B	19 cm - 7 1/2"
04-232-21	04-233-21	04-233-21B	21 cm - 8 1/4"
04-232-23	04-233-23	04-233-23B	23 cm - 9"

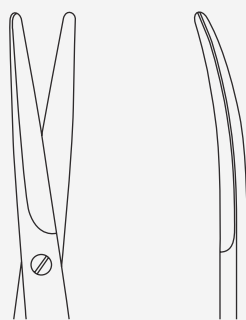

**Mayo**

04-234-14T	04-335-14T
14 cm - 5 1/2"	14 cm - 5 1/2"
04-234-17T	04-335-17T
17 cm - 6 3/4"	17 cm - 6 3/4"
04-234-23T	04-335-23T
23 cm - 9"	23 cm - 9"
04-236-14S	04-237-14S
14 cm - 5 1/2"	14 cm - 5 1/2"
04-236-17S	04-237-17S
17 cm - 6 3/4"	17 cm - 6 3/4"
04-236-23S	04-237-23S
23 cm - 9"	23 cm - 9"
04-236-25S	04-237-25S
25 cm - 10"	25 cm - 10"

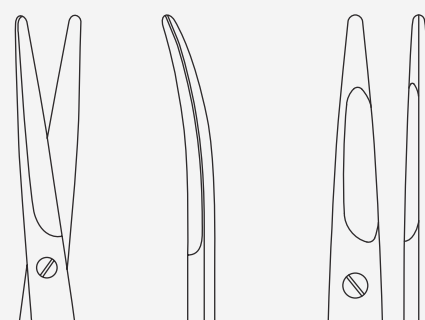

**Mayo-Style**

04-238-15T	04-239-15T	
15 cm - 6"	15 cm - 6"	
04-238-17T	04-239-17T	04-240-17T
17 cm - 6 3/4"	17 cm - 6 3/4"	17 cm - 6 3/4"
04-241-15S	04-242-15S	
15 cm - 6"	15 cm - 6"	
04-241-17S	04-242-17S	
17 cm - 6 3/4"	17 cm - 6 3/4"	





**Mayo-Lexer**

04-243-16T

16.5 cm - 6 1/2"

04-245-16S

16.5 cm - 6 1/2"



04-244-16T

16.5 cm - 6 1/2"

04-246-16S

16.5 cm - 6 1/2"

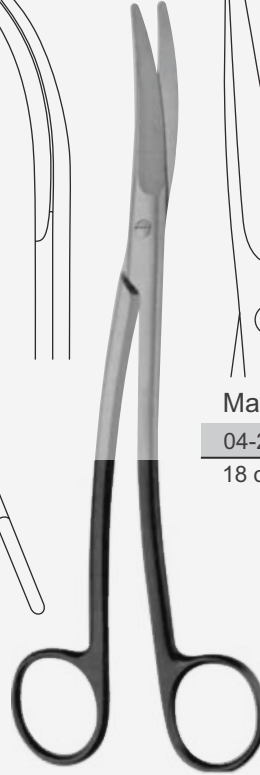
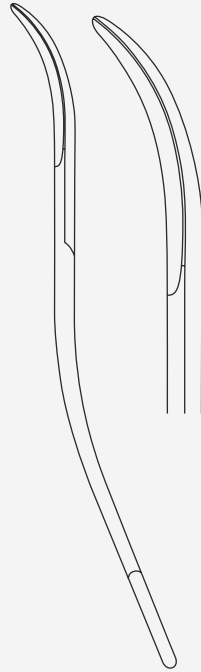

**Mayo**

04-247-18S

18 cm - 7"



04-248-23S

23 cm - 9"

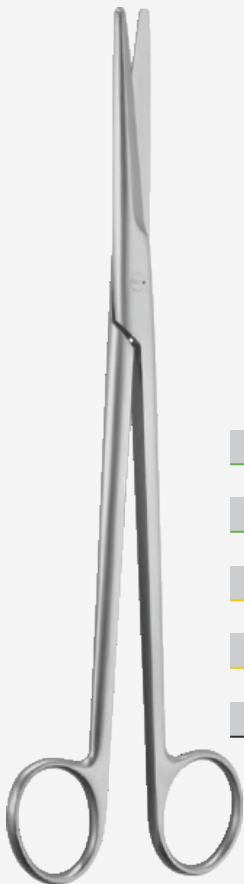

**Mayo-Harrington**

04-249-20

20 cm - 8"

04-249-23

23 cm - 9"

04-249-20T

20 cm - 8"

04-249-23T

23 cm - 9"

04-249-30S

30 cm - 12"



04-250-20

20 cm - 8"

04-250-23

23 cm - 9"

04-250-20T

20 cm - 8"

04-250-23T

23 cm - 9"

04-250-30S

30 cm - 12"

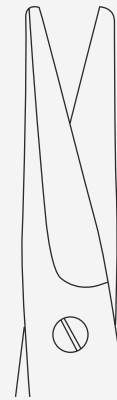

**Mayo-Noble**

04-351-17

17 cm - 6 3/4"



04-352-17

17 cm - 6 3/4"

Parametrium scissors  
 Parametriumscheren  
 Parametrium tijeras  
 Parametrium ciseaux  
 forbici parametrio

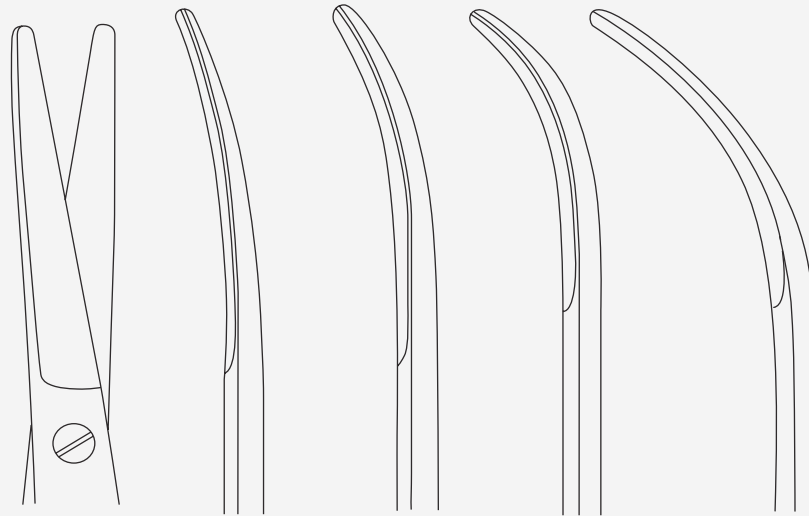

Parametrium

04-249-23

04-250-23

04-251-23

04-252-23

04-253-23

23 cm - 9"

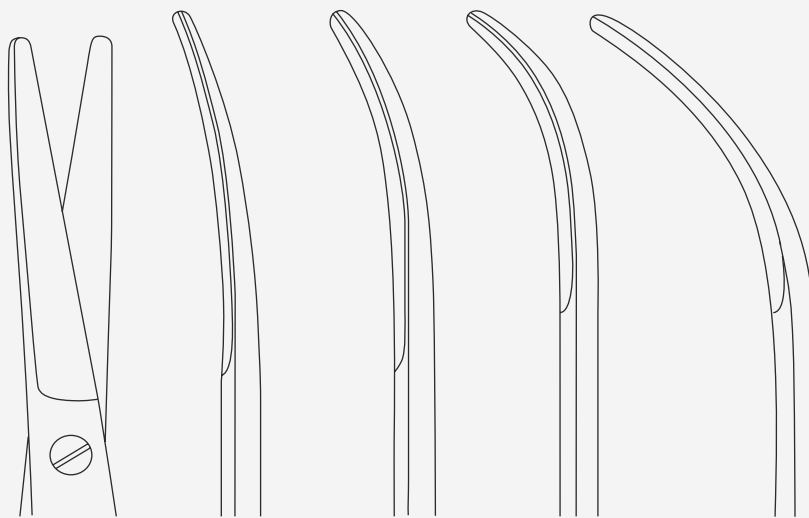

Parametrium

04-254-23T

04-255-23T

04-256-23T

04-257-23T

04-258-23T

23 cm - 9"

04-254-28T

04-255-28T

04-256-28T

04-257-28T

04-258-28T

28 cm - 11"

04-254-32T

04-255-32T

04-256-32T

04-257-32T

04-258-32T

32 cm - 12"



**Metzenbaum**

04-259-14

14.5 cm - 5 3/4"

04-259-15

15 cm - 6"

04-259-18

18 cm - 7"

04-259-20

20 cm - 8"

04-259-23

23 cm - 9"

04-259-25

25 cm - 10"

04-259-28

28 cm - 11"

04-259-30

30 cm - 12"

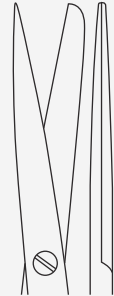

04-260-14

14.5 cm - 5 3/4"



04-261-14

14.5 cm - 5 3/4"

04-261-18

18 cm - 7"

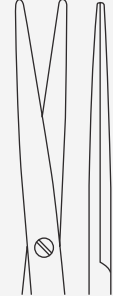

04-262-14

14.5 cm - 5 3/4"

04-262-18

18 cm - 7"

04-262-20

20 cm - 8"

04-262-23

23 cm - 9"

fine  
fein  
multa  
amende



**Metzenbaum**

04-263-14

14.5 cm - 5 3/4"

04-263-15

15 cm - 5 3/4"

04-263-18

18 cm - 7"

04-263-20

20 cm - 8"

04-263-23

23 cm - 9"

04-263-25

25 cm - 10"

04-263-28

28 cm - 11"

04-263-30

30 cm - 12"

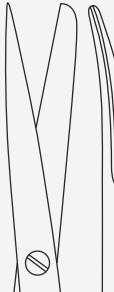

04-264-14

14.5 cm - 5 3/4"

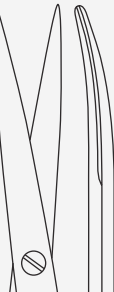

04-265-14

14.5 cm - 5 3/4"

04-265-18

18 cm - 7"

04-265-20

20 cm - 8"



04-266-14

14.5 cm - 5 3/4"

04-266-18

18 cm - 7"

04-266-20

20 cm - 8"

04-266-23

23 cm - 9"

fine  
fein  
multa  
amende

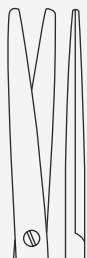

**Metzenbaum**

04-266-11T	04-267-23T
11.5 cm - 4 1/2"	23 cm - 9"
04-266-14T	04-267-25T
14.5 cm - 5 3/4"	25 cm - 10"
04-266-18T	04-267-28T
18 cm - 7"	28 cm - 11"
04-266-20T	04-267-30T
20 cm - 8"	30 cm - 12"
04-268-11S	04-269-18S
11.5 cm - 4 1/2"	18 cm - 7"
04-268-14S	04-269-20S
14.5 cm - 5 3/4"	20 cm - 8"
04-268-16S	
16 cm - 6 1/4"	



04-270-14T
14.5 cm / 5 3/4"



04-271-14T
14.5 cm / 5 3/4"

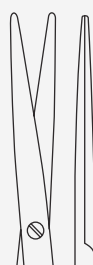

04-272-14T	04-273-14S
14.5 cm - 5 3/4"	14.5 cm - 5 3/4"
04-272-18T	04-273-17S
18 cm - 7"	17 cm - 6 3/4"
04-272-20T	04-273-18S
20 cm - 8"	18 cm - 7"
04-272-23T	
23 cm - 9"	
04-272-25T	
25 cm - 10"	
04-272-28T	
28 cm - 11"	

fine  
 fein  
 multa  
 amende

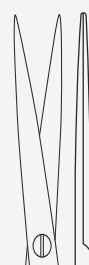

04-274-14T
14.5 cm / 5 3/4"
04-274-18T
18 cm - 7"
04-274-23T
23 cm - 9"

fine  
 fein  
 multa  
 amende



**Metzenbaum**

04-275-11T	04-275-33T
11.5 cm - 4 1/2"	33 cm - 13"
04-275-14T	04-275-36T
14.5 cm - 5 3/4"	36 cm - 14 1/2"
04-275-18T	04-275-38T
18 cm - 7"	38 cm - 15"
04-275-20T	04-276-23S
20 cm - 8"	23 cm - 9"
04-275-23T	04-276-25S
23 cm - 9"	25 cm - 10"
04-275-25T	04-276-28S
25 cm - 10"	28 cm - 11"
04-275-28T	04-276-30S
28 cm - 11"	30 cm - 12"
04-275-30T	04-276-36S
30 cm - 12"	36 cm - 14 1/2"



04-277-14T
14.5 cm - 5 3/4"



04-278-14T
14.5 cm - 5 3/4"



04-280-14S	04-279-14T
14.5 cm - 5 3/4"	14.5 cm - 5 3/4"
04-280-17S	04-279-18T
17 cm - 6 3/4"	18 cm - 7"
04-280-18S	04-279-20T
18 cm - 7"	20 cm - 8"
	04-279-23T
	23 cm - 9"
	04-279-25T
	25 cm - 10"
	04-279-28T
	28 cm - 11"
	fine
	fein
	multa
	amende

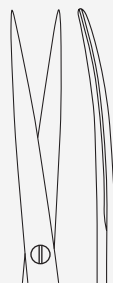

04-281-14T	
14.5 cm - 5 3/4"	
04-281-18T	
18 cm - 7"	
04-281-23T	
23 cm - 9"	
04-281-28T	
28 cm - 11"	
04-281-33T	
33 cm - 13"	
04-281-36T	
36 cm - 14 1/2"	
	fine
	fein
	multa
	amende



04-282-14T	
14 cm - 5 1/2"	
04-282-18T	
18 cm - 7"	
04-282-20T	
20 cm - 8"	
04-282-23T	
23 cm - 9"	
04-282-25T	
25 cm - 10"	
	standard, serrated
	Standard gezackten
	dentada estándar
	dentelé norme

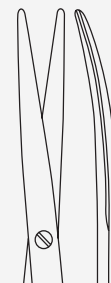

04-283-14T	
14.5 cm - 5 3/4"	
04-283-18T	
18 cm - 7"	
	fine serrated
	fein gezackten
	multa dentada
	amende dentelé



04-284-20T	
20 cm - 8"	
04-284-23T	
23 cm - 9"	
04-284-28T	
28 cm - 11"	
	strong curved
	stark gebogen
	muy curvado
	fortement incurvée



**Nelson**

04-284-18

04-284-20

04-284-23

04-284-26

04-284-28

04-284-30



04-285-18

04-285-20

04-285-23

04-285-26

04-285-28

04-285-30



04-286-18

18 cm - 7"

04-286-20

20 cm - 8"

04-286-23

23 cm - 9"

04-286-26

26 cm - 10 1/4"

04-286-28

28 cm - 11"

04-286-30

30 cm - 12"



**Nelson**

04-284-18A

04-284-20A

04-284-23A

04-284-26A

04-284-28A

04-284-30A



04-284-17B

04-284-20B

04-284-23B

04-284-26B

04-284-28B

04-284-30B



04-285-17C

18 cm - 7"

04-285-20C

20 cm - 8"

04-285-23C

23 cm - 9"

04-285-26C

26 cm - 10 1/4"

04-285-28C

28 cm - 11"

04-285-30C

30 cm - 12"



**Nelson**

04-286-18T

04-286-20T

04-286-23T

04-286-26T

04-286-28T

04-286-30T

04-289-23S

04-289-26S

04-289-30S



04-287-18T

04-287-20T

04-287-23T

04-287-26T

04-287-28T

04-287-30T

04-287-23S

04-287-26S

04-287-30S



04-288-18T

18 cm - 7"

04-288-20T

20 cm - 8"

04-288-23T

23 cm - 9"

04-288-26T

26 cm - 10 1/4"

04-288-28T

28 cm - 11"

04-288-30T

30 cm - 12"

04-288-23S

23 cm - 9"

04-288-26S

26 cm - 10 1/4"

04-288-30S

30 cm - 11 3/4"



**Nelson**

04-290-18T

04-290-20T

04-290-23T

04-290-26T

04-290-28T

04-290-30T

04-293-23S

04-293-26S

04-293-30S



04-291-18T

04-291-20T

04-291-23T

04-291-26T

04-291-28T

04-291-30T

04-291-23S

04-291-26S

04-291-30S



04-292-18T

18 cm - 7"

04-292-20T

20 cm - 8"

04-292-23T

23 cm - 9"

04-292-26T

26 cm - 10 1/4"

04-292-28T

28 cm - 11"

04-292-30T

30 cm - 12"

04-292-23S

23 cm - 9"

04-292-26S

26 cm - 10 1/4"

04-292-30S

30 cm - 11 3/4"

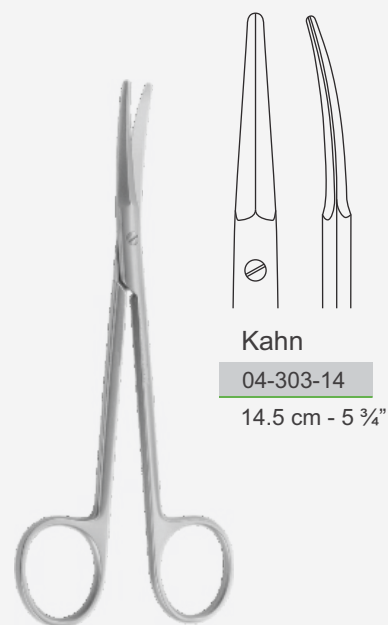
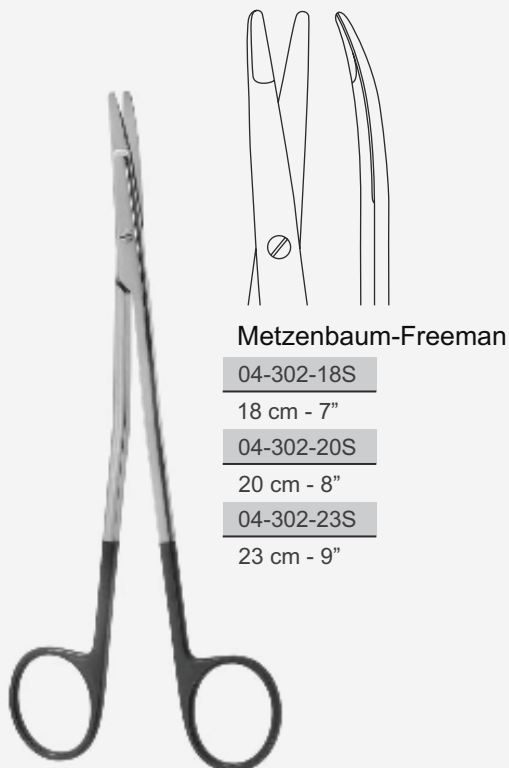
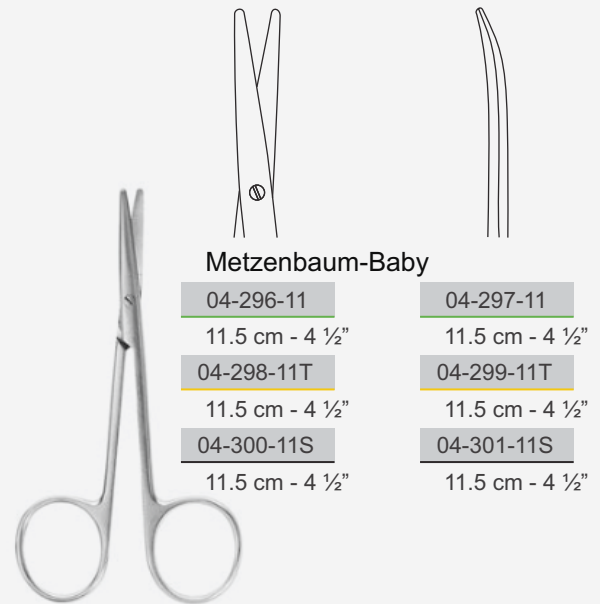
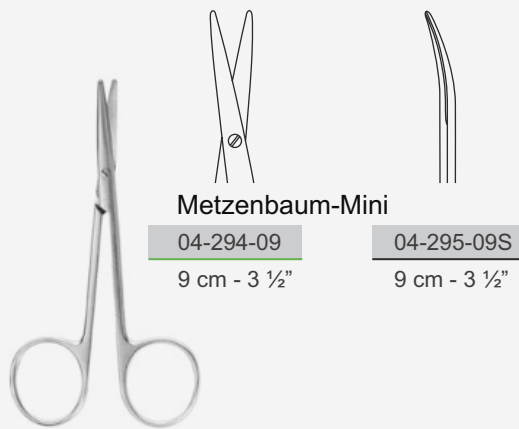





Metzenbaum-Fino

04-325-14	04-326-14
04-325-18	04-326-18
04-325-22	04-326-22
04-325-23	04-326-23

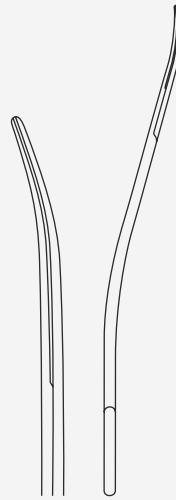

04-327-14	14.5 cm - 5 3/4"
04-327-18	18 cm - 7"
04-327-22	22 cm - 8"
04-327-23	23 cm - 9"

S-curved  
S-förmig gebogen  
curva en S  
courbes en S



Metzenbaum-Lahey

04-304-14T
14.5 cm - 5 3/4"



Metzenbaum - Fino

04-328-14T	04-329-14T	14.5 cm - 5 3/4"
04-328-18T	04-329-18T	18 cm - 7"
04-328-20T	04-329-20T	20 cm - 8"
04-328-23T	04-329-23T	23 cm - 9"

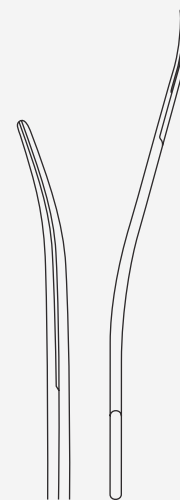

Metzenbaum - Fino

04-330-18T	04-331-18T	18 cm - 7"
04-330-20T	04-331-20T	20 cm - 8"
04-330-23T	04-331-23T	23 cm - 9"

S-curved  
S-förmig gebogen  
curva en S  
courbes en S

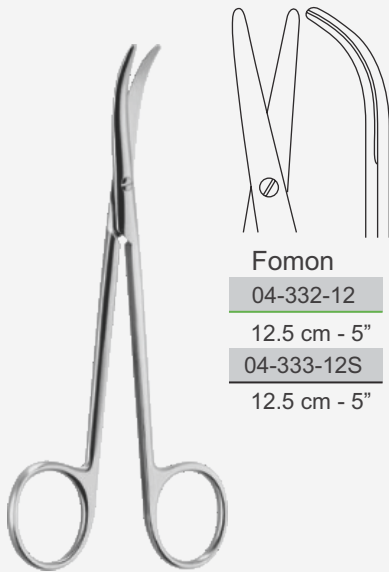

**Fomon**

04-332-12

12.5 cm - 5"

04-333-12S

12.5 cm - 5"



**Thorek**

04-334-19

19 cm - 7 1/2"

04-334-25S

25 cm - 10"



**Sweet**

04-335-21

21.6 cm - 8 1/2"



Fig. 1

Fig. 2

**Dixon**

03-159-15 Fig. 1

03-160-15 Fig. 2

15 cm / 6"

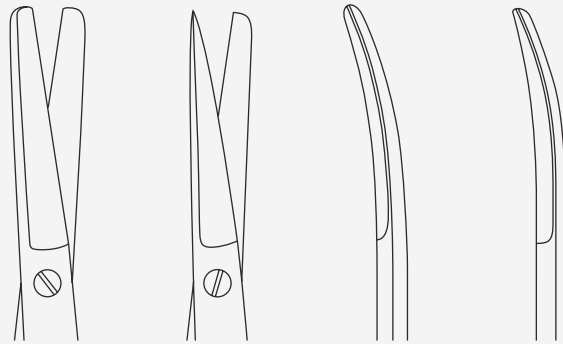
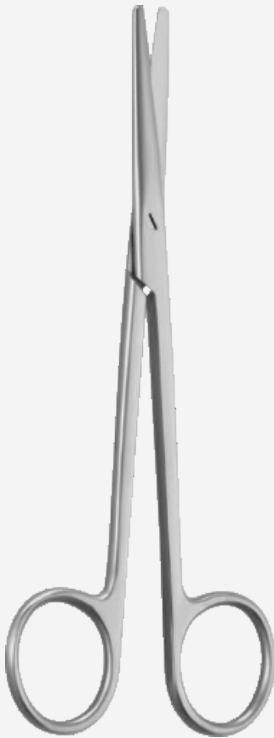

**Sims**

04-337-20	04-338-20	04-339-20	04-340-20	20 cm - 8"
04-337-23	04-338-23	04-339-23	04-340-23	23 cm - 9"
04-341-20T	04-342-20T	04-343-20T	04-344-20T	20 cm - 8"
04-341-23T	04-342-23T	04-343-23T	04-344-23T	23 cm - 9"
04-345-20S	04-346-20S	04-347-20S	04-348-20S	20 cm - 8"
04-345-23S	04-346-23S	04-347-23S	04-348-23S	23 cm - 9"

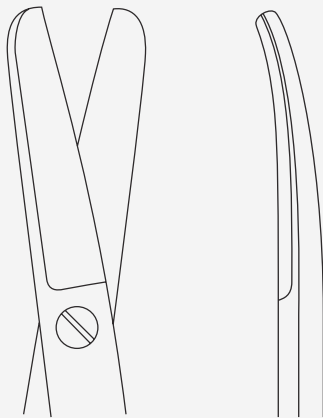

**Dubois**

04-349-27

27 cm / 10 3/4"

04-350-27

27 cm / 10 3/4"

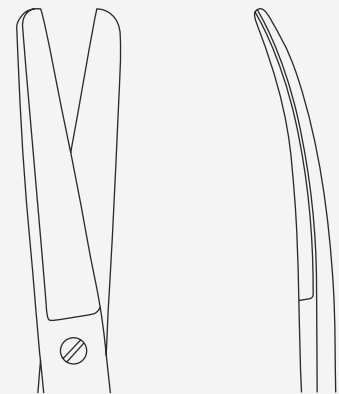

**Doyen**

04-351-16

16 cm - 6 1/4"

04-351-18

18 cm - 7 1/8"

04-353-18T

18 cm - 7 1/8"

04-352-16

16 cm - 6 1/4"

04-352-18

18 cm - 7 1/8"

04-354-18T

18 cm - 7 1/8"

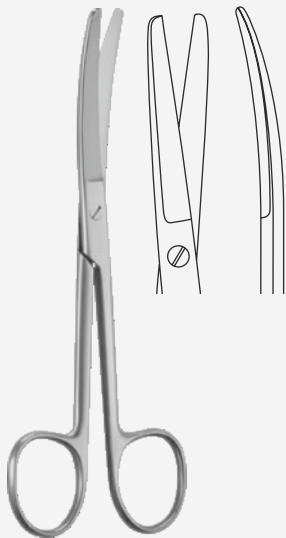

**Wertheim**

04-305-14

14.5 cm - 5 3/4"

04-304-14

14.5 cm - 5 3/4"

04-305-20

20 cm - 8"

04-304-20

20 cm - 8"

04-305-23

23 cm - 9"

04-304-23

23 cm - 9"

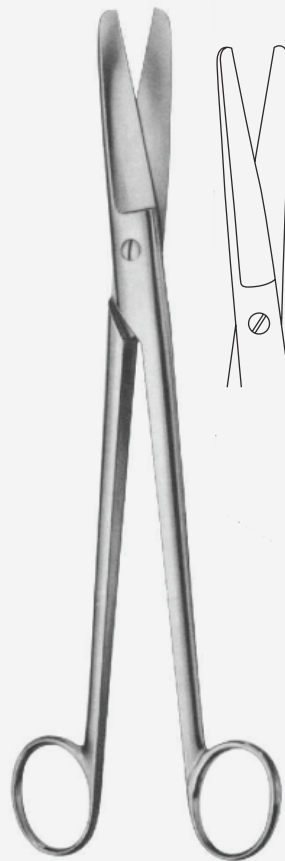

**Sims-Siebold**

04-355-25

25 cm - 10"

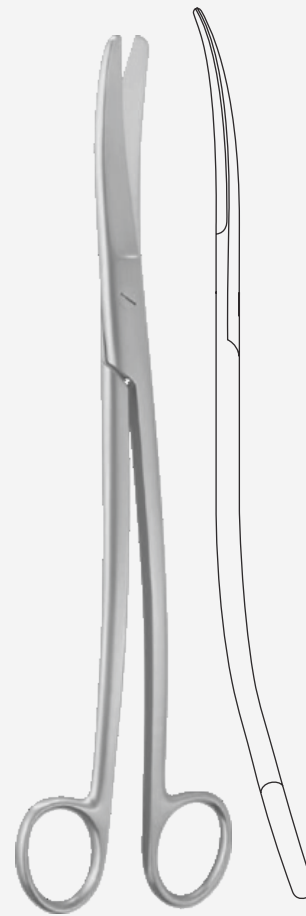

**Siebold**

04-356-24

24 cm - 9 1/2"

S-curved  
 S-förmig gebogen  
 curva en S  
 courbes en S

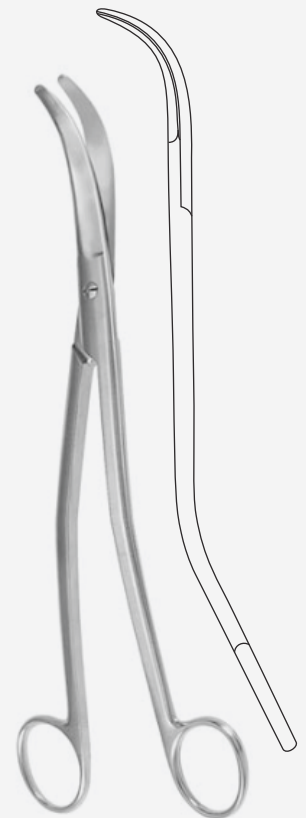

**Bozemann**

04-357-22

22 cm - 8 3/4"

S-curved  
 S-förmig gebogen  
 curva en S  
 courbes en S



**Wagner**

04-358-12

gerade  
straight  
droits  
recta  
rette



04-359-12

gerade  
straight  
droits  
recta  
rette



04-360-12

gerade  
straight  
droits  
recta  
rette



04-361-12

gerade, gezahnt  
straight, saw edge  
droits, dentelés  
recta, dentada  
rette, dentate



04-362-12

gerade, gezahnt  
straight, saw edge  
droits, dentelés  
recta, dentada  
rette, dentate



04-363-12

gerade, gezahnt  
straight, saw edge  
droits, dentelés  
recta, dentada  
rette, dentate

12 cm - 4 3/4"



04-364-12

gebogen  
curved  
courbes  
curva  
curve



04-365-12

gebogen  
curved  
courbes  
curva  
curve



04-366-12

gebogen  
curved  
courbes  
curva  
curve



04-367-12

gebogen, gezahnt  
curved, saw edge  
courbes, dentelés  
curva, dentada  
curve, dentate



04-368-12

gebogen, gezahnt  
curved, saw edge  
courbes, dentelés  
curva, dentada  
curve, dentate



04-369-12

gebogen, gezahnt  
curved, saw edge  
courbes, dentelés  
curva, dentada  
curve, dentate

12 cm - 4 3/4"



04-370-10

10.5 cm - 4 1/8"

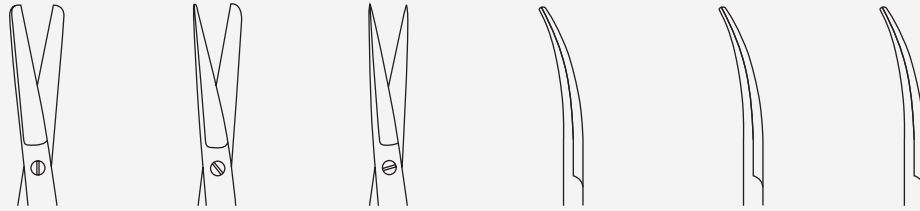

**Standard - Fino**

04-371-12

04-372-12

04-373-12

04-374-12

04-375-12

04-376-12

12 cm - 4 3/4"

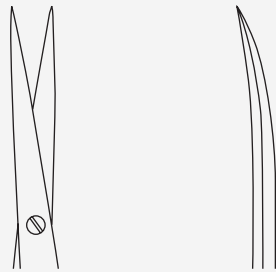

**Brophy (Sullivan)**

04-377-14

14.5 cm - 5 3/4"

04-378-14

14.5 cm - 5 3/4"

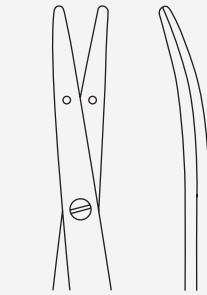

**Littler**

04-379-12

12 cm / 4 3/4"

04-379-14

14.5 cm / 5 3/4"

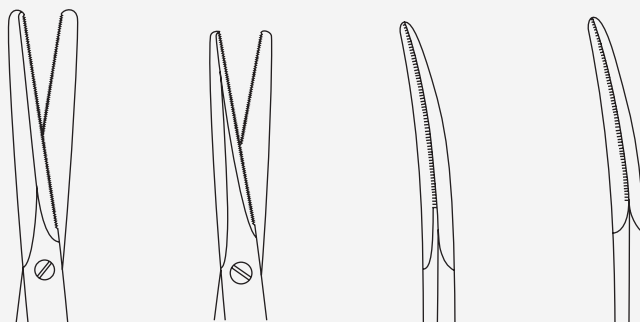

**Beuse**

04-380-14

14 cm / 5 1/2"

04-381-18

18 cm / 7 1/8"

04-382-14

14 cm / 5 1/2"

04-383-18

18 cm / 7 1/8"

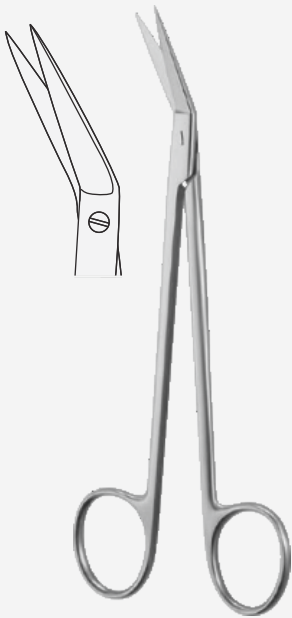

Locklin

04-384-16

16 cm - 6 1/8"  
straight, saw edge  
gerade, gezahnt  
recta, dentada  
droits, dentelés

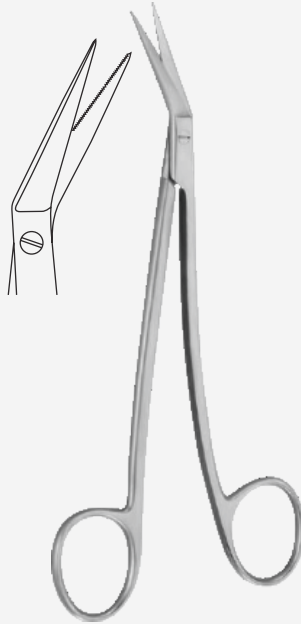

04-385-16

16 cm - 6 1/8"  
curved  
gebogen  
curva  
courbes

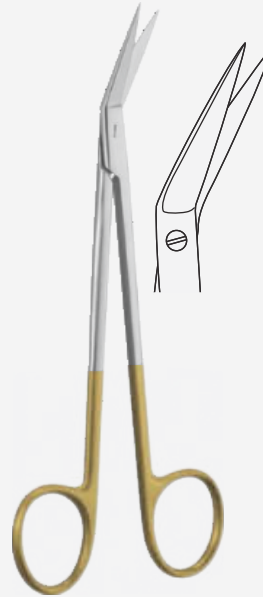

Locklin

04-386-16T

16 cm - 6 1/8"  
straight, saw edge  
gerade, gezahnt  
recta, dentada  
droits, dentelés



04-387-16T

16 cm - 6 1/8"  
curved, saw edge  
gebogen, gezahnt  
curva, dentada  
courbes, dentelés

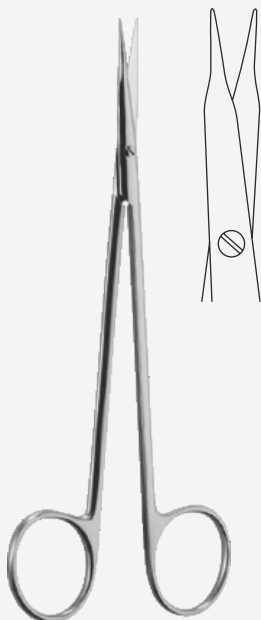

Reynolds

04-388-12

12 cm - 4 3/4"

04-388-14

14 cm - 5 1/2"

04-388-16

16 cm - 6 1/4"

04-388-18

18 cm - 7"

04-389-14T

14 cm - 5 1/2"

04-390-12S

12 cm - 4 3/4"

04-390-16S

16 cm - 6 1/4"

04-390-18S

18 cm - 7"

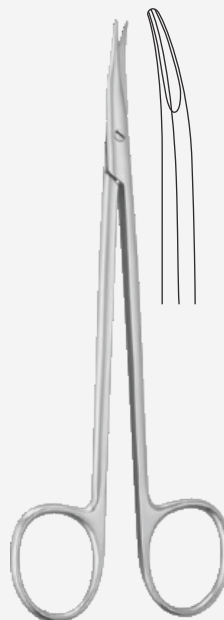

Reynolds

04-391-12

12 cm - 4 3/4"

04-391-14

14 cm - 5 1/2"

04-391-16

16 cm - 6 1/4"

04-391-18

18 cm - 7"

04-392-14T

14 cm - 5 1/2"

04-393-12S

12 cm - 4 3/4"

04-393-16S

16 cm - 6 1/4"

04-393-18S

18 cm - 7"

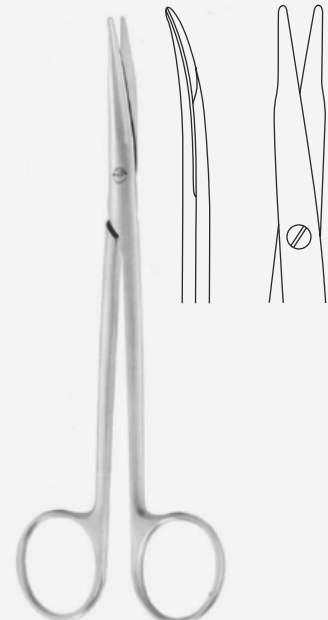

Jameson

04-394-15

15 cm - 6"

04-394-18

18 cm - 7 1/8"

04-395-14T

14 cm - 5 1/2"

04-396-14S

14 cm - 5 1/2"

04-396-18S

18 cm - 7 1/8"

04-396-25S

25 cm - 9 3/4"

04-396-28S

28 cm - 11"



Quinby

04-397-12

12.5 cm - 6"

04-398-12

12.5 cm - 6"



Niro

04-399-14

14 cm - 5 1/2"

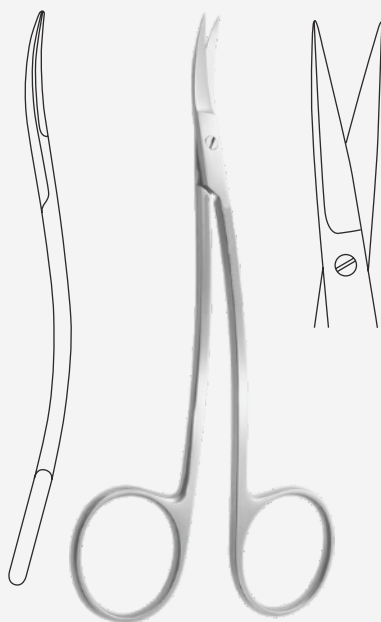

La Grange

04-400-14

14 cm - 5 1/2"



Neumann

04-401-12

12 cm - 4 3/4"

S-curved  
 S-förmig gebogen  
 curva en S  
 courbes en S

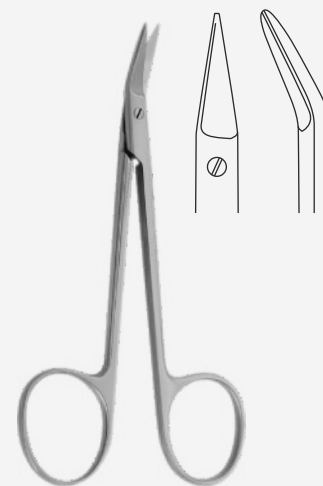

Walter

04-402-10

10 cm - 4"

angled  
 abgewinkelt  
 angular  
 abgewinkelt





**Knapp**

04-403-10

10.5 cm - 4 1/4"

blunt  
stumpf  
roma  
mousses



04-404-10

10.5 cm - 4 1/4"



**Knapp**

04-405-12

12.5 cm - 5"

04-407-12T

12.5 cm - 5"

04-409-12S

12.5 cm - 5"



04-404-12

12.5 cm - 5"

04-408-12T

12.5 cm - 5"

04-410-12S

12.5 cm - 5"



**Knapp**

04-411-12

04-415-12S

sharp  
spitz  
puntiagudo  
pointu



04-412-12

04-412-12S

blunt  
stumpf  
roma  
mousses



04-413-12

04-416-12S

sharp  
spitz  
puntiagudo  
pointu



04-414-12

04-414-12S

blunt  
stumpf  
roma  
mousses

12 cm - 4 3/4"

12 cm - 4 3/4"



**Knapp**

04-417-10

10 cm - 4"



04-418-10

10 cm - 4"



**Knapp**

04-419-09

9.5 cm - 3 3/4"

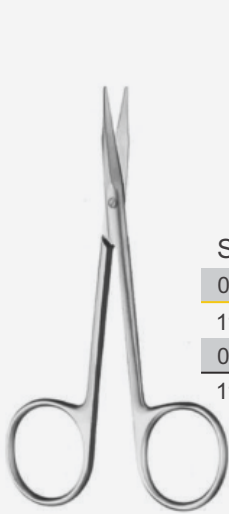

**Siegert**

04-420-11T

11.5 cm - 4 1/2"

04-422-11S

11.5 cm - 4 1/2"



04-421-11T

11.5 cm - 4 1/2"

04-423-11S

11.5 cm - 4 1/2"



**Shea**

04-424-12

12 cm - 4 3/4"

04-425-12S

12 cm - 4 3/4"

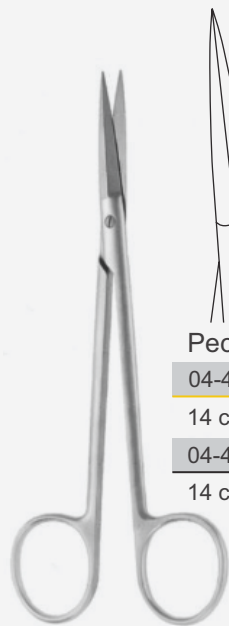

**Peck-Joseph**

04-427-14T

14 cm - 5 1/2"

04-431-14S

14 cm - 5 1/2"



04-428-14T

14 cm - 5 1/2"

04-432-14S

14 cm - 5 1/2"



04-429-14T

14 cm - 5 1/2"

04-433-14S

14 cm - 5 1/2"



04-430-14T

14 cm - 5 1/2"

04-434-14S

14 cm - 5 1/2"



**Goldmann-Fox**

04-435-13

13 cm - 5 1/8"  
 Saw edge



04-436-13

13 cm - 5 1/8"  
 Saw edge



04-437-13T

13 cm - 5 1/8"



04-438-13T

13 cm - 5 1/8"

04-439-13S

13 cm - 5 1/8"

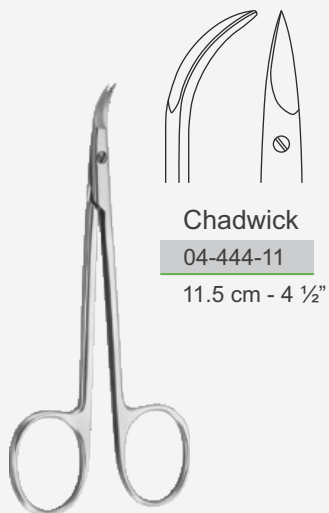
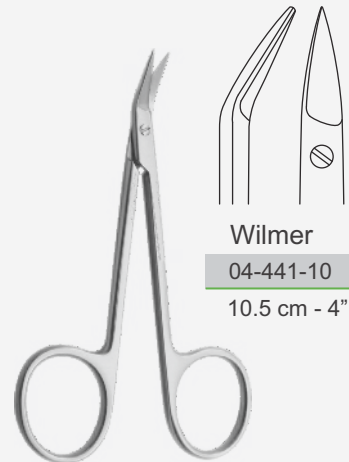

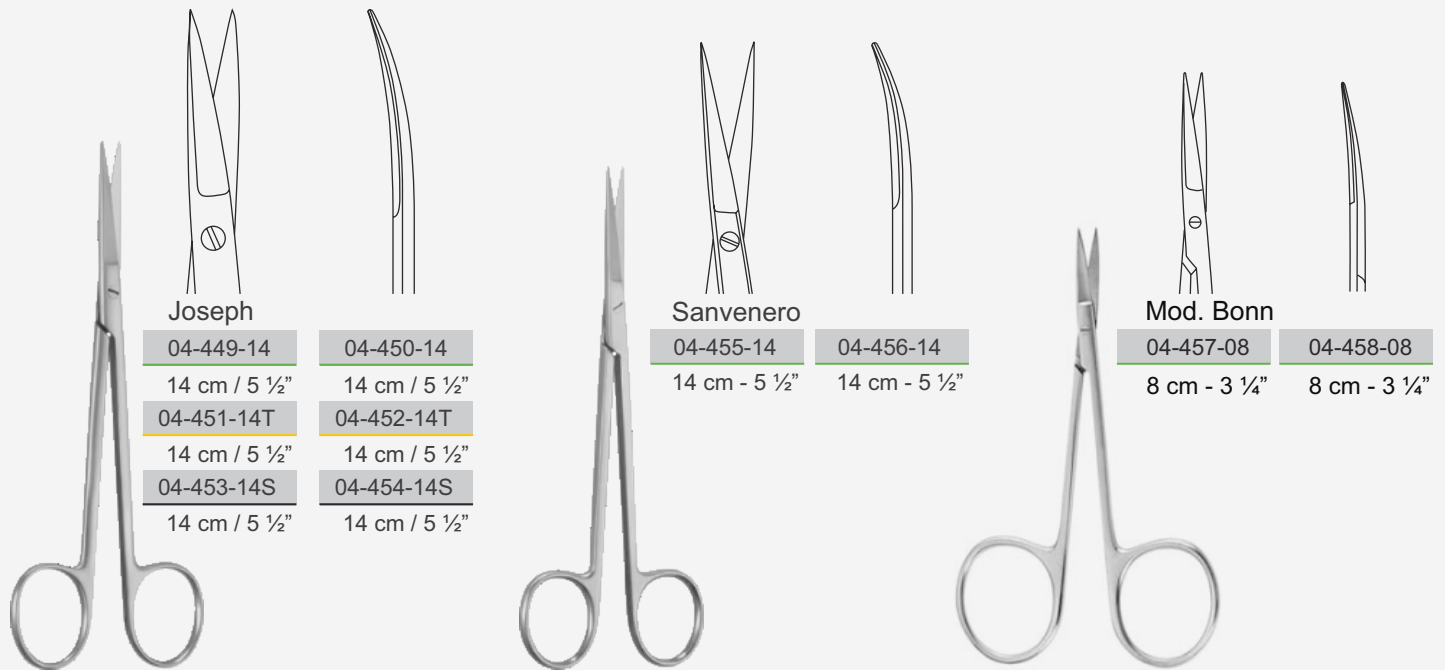

Joseph

04-449-14

14 cm / 5 1/2"

04-451-14T

14 cm / 5 1/2"

04-453-14S

14 cm / 5 1/2"

04-450-14

14 cm / 5 1/2"

04-452-14T

14 cm / 5 1/2"

04-454-14S

14 cm / 5 1/2"

Sanvenero

04-455-14

14 cm - 5 1/2"

04-456-14

14 cm - 5 1/2"

Mod. Bonn

04-457-08

8 cm - 3 1/4"

04-458-08

8 cm - 3 1/4"



Kilner (Ragnell)

04-459-13

13.5 cm - 5"

04-460-12

12 cm - 4 3/4"

04-460-15

15 cm - 6"

04-460-18

18 cm - 7"

04-461-12T

12 cm - 4 3/4"

04-461-15T

15 cm - 6"

04-461-18T

18 cm - 7"

04-462-12S

12 cm - 4 3/4"

04-462-15S

15 cm - 6"

04-462-18S

18 cm - 7"

04-462-20S

20 cm - 8"

04-462-23S

23 cm - 9"

04-463-11

11 cm - 4 1/4"

straight  
 gerade  
 recta  
 droits

curved  
 gebogen  
 curva  
 courbes

curved  
 gebogen  
 curva  
 courbes

curved  
 gebogen  
 curva  
 courbes

fine  
 fein  
 multa  
 amende

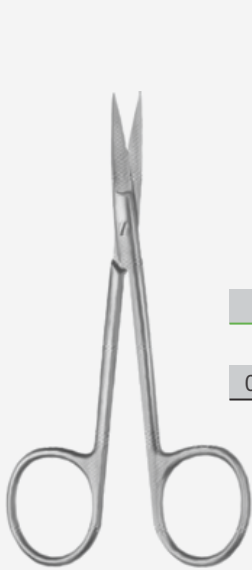

**Jabaley**

04-464-13

13 cm - 5 1/8"

04-466-13S

13 cm - 5 1/8"



04-465-13

13 cm - 5 1/8"

04-467-13S

13 cm - 5 1/8"

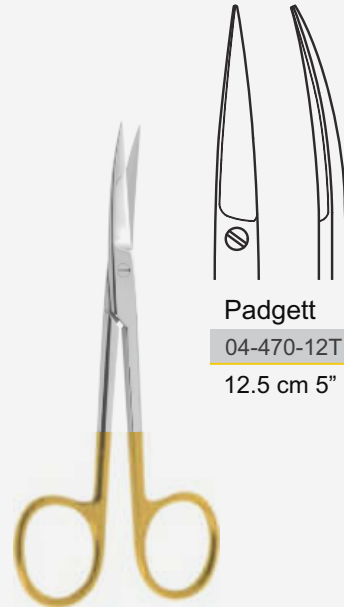

**Padgett**

04-470-12T

12.5 cm 5"



**Davis**

04-471-18T

18 cm 7"

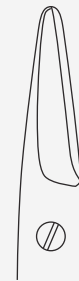

**Castanares**

04-472-16S

16 cm / 6 1/4"

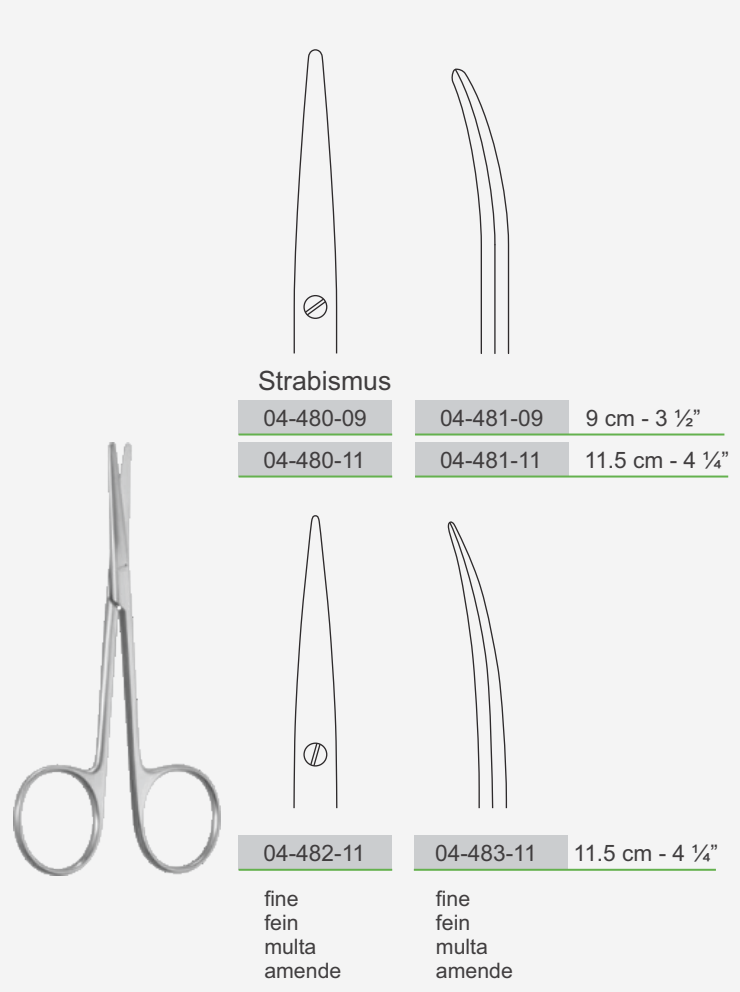
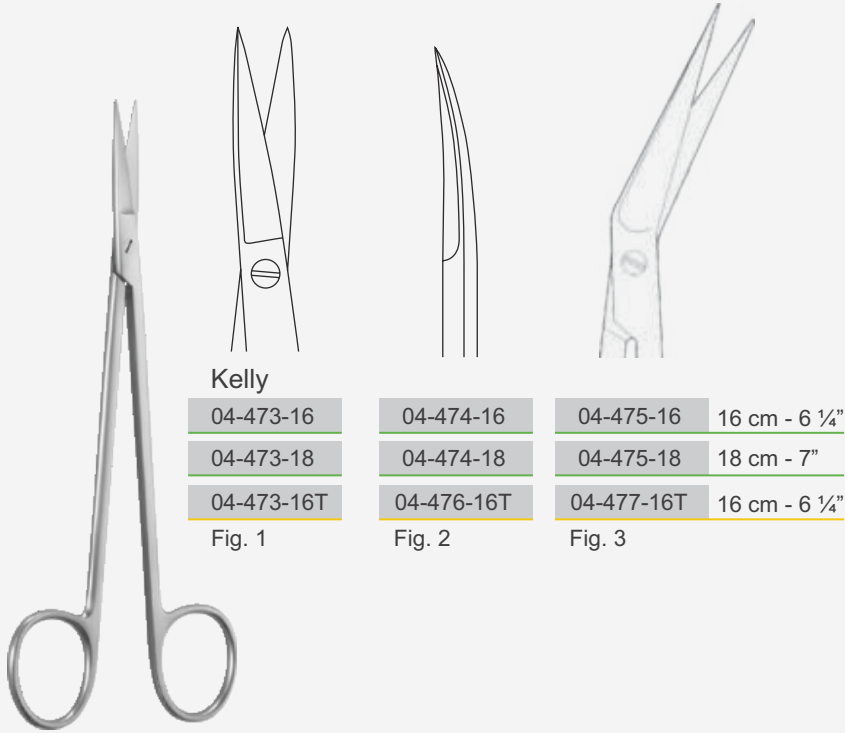

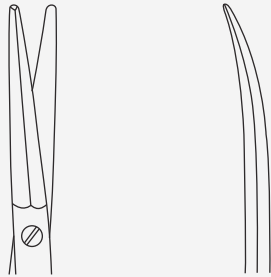
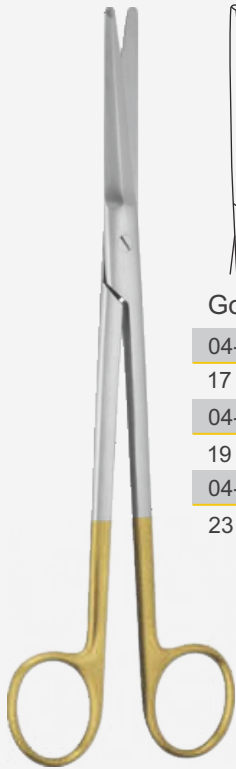

**Gorney**

04-488-17T

17 cm - 6 ¾ "

04-488-19T

19 cm - 6 ½ "

04-488-23T

23 cm - 9 "

04-489-17T

17 cm - 6 ¾ "

04-489-19T

19 cm - 6 ½ "

04-489-23T

23 cm - 9 "

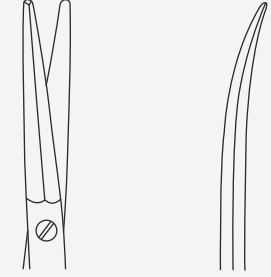

**Gorney**

04-490-17S

17 cm - 6 ¾ "

04-490-19S

19 cm - 6 ½ "

04-490-23S

23 cm - 9 "

04-491-17S

17 cm - 6 ¾ "

04-491-19S

19 cm - 6 ½ "

04-491-23S

23 cm - 9 "

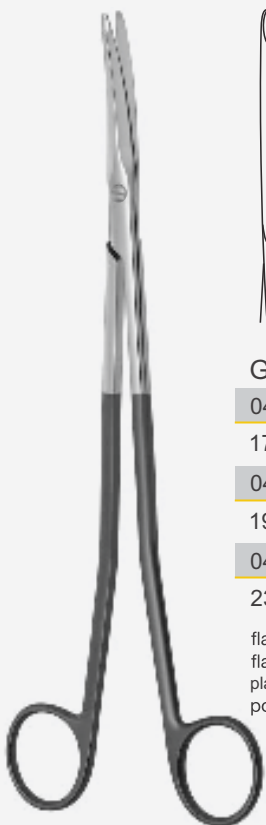

**Gorney-Freeman**

04-492-17T

17 cm - 6 ¾ "

04-492-19T

19 cm - 6 ½ "

04-492-23T

23 cm - 6 "

04-493-17S

17 cm - 6 ¾ "

04-493-19S

19 cm - 6 ½ "

04-493-23S

23 cm - 6 "

flat tips  
flache Spitzen  
planes de Puntas  
pointes plates

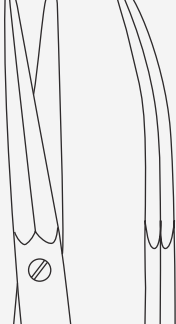
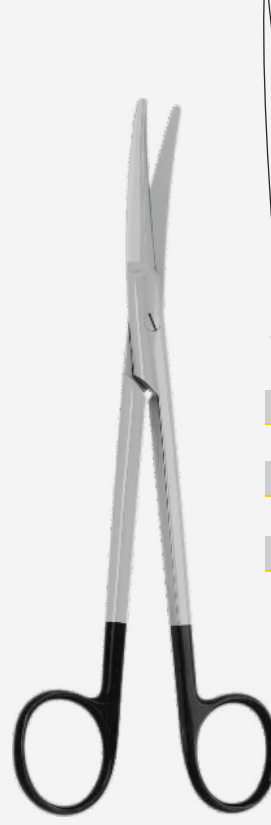

**Kaye**

04-499-15T

15 cm - 6 "

04-499-19T

19 cm - 7 ½ "

04-499-23T

23 cm - 9 "

04-500-15S

15 cm - 6 "

04-500-17S

17 cm - 6 ¾ "

04-500-19S

19 cm - 7 ½ "

04-500-23S

23 cm - 9 "



Kaye

04-502-11

11.5 cm - 4 ½ "

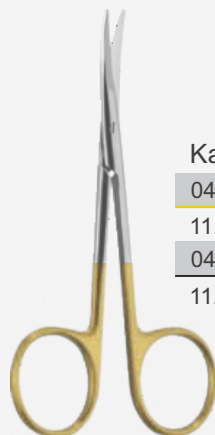

Kaye

04-503-11T

11.5 cm - 4 ½ "

04-504-11S

11.5 cm - 4 ½ "



Kaye

04-505-11S

11.5 cm - 4 ½ "

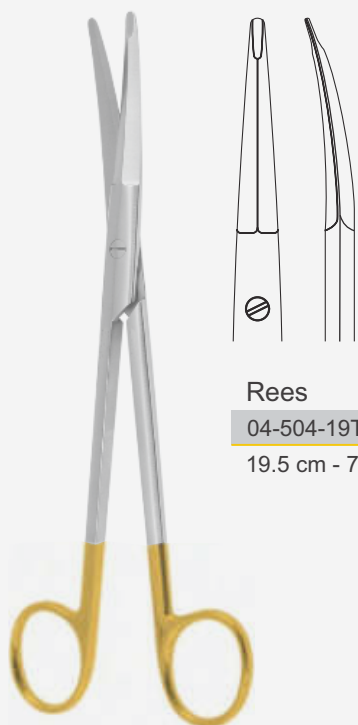

Rees

04-504-19T

19.5 cm - 7 ¾ "



Hinderer

04-507-19T

19.5 cm - 7 ¾ "



Kaye-Freeman

04-508-18T

18 cm - 7 "

04-510-18S

18 cm - 7 "



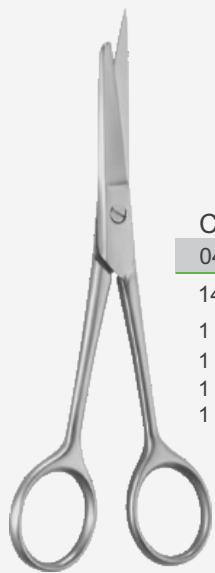

**Carlos**

04-511-14

14.5 cm - 5 ¾"

- 1 Blade with probe
- 1 Blatt mit Sondenspitze
- 1 Punta forma sonda
- 1 Lame avec sonde



**Perwitschky**

04-512-11

11.5 cm - 4 ½"



04-513-11

11.5 cm - 4 ½"

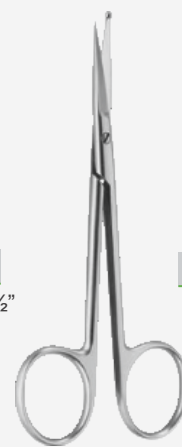

**Perwitschky**

04-514-11

11.5 cm - 4 ½"



04-515-11

11.5 cm - 4 ½"

- probe-pointed tip
- geknöpfte Spitze
- top abotonado
- haut boutoné



**Lincoln**

04-516-17

17 cm - 6 ¾"



04-517-17

17 cm - 6 ¾"

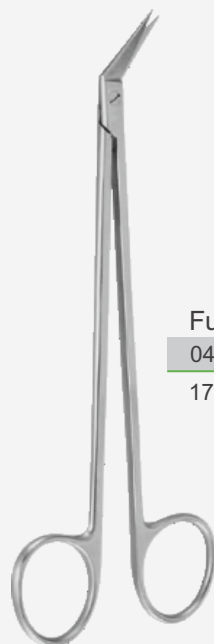

**Fulton**

04-518-17

17 cm - 6 ¾"

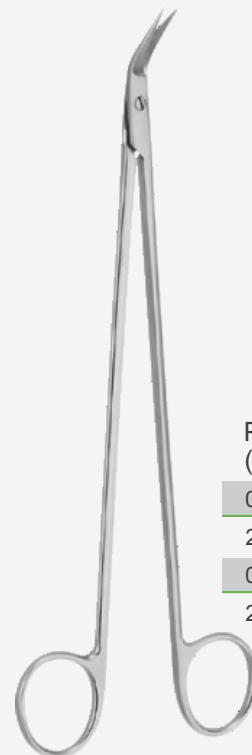

**Potts-Smith  
(de Martel)**

04-519-45 45°

21 cm - 8 ¼"

04-519-60 60°

21 cm - 8 ¼"



**Willauer**

04-520-25

25 cm - 10"

04-520-28

28 cm - 11"

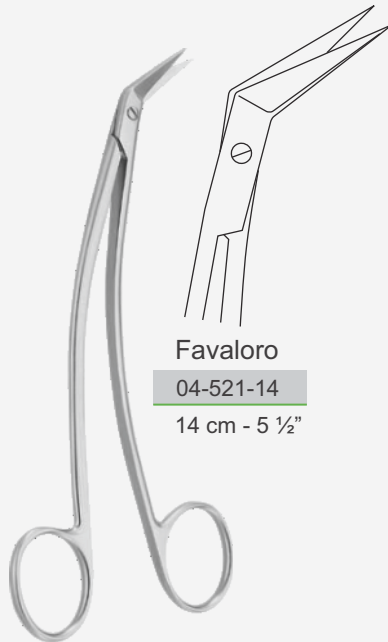

**Favaloro**

04-521-14

14 cm - 5 1/2"

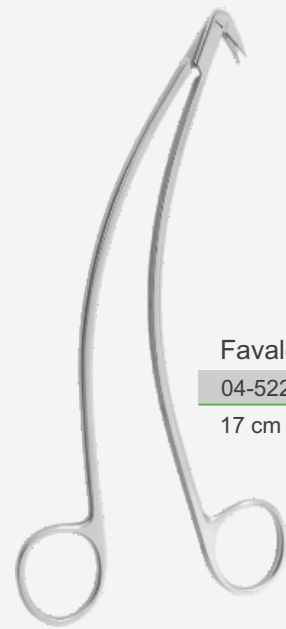

**Favaloro**

04-522-17

17 cm - 6 3/4"

130°

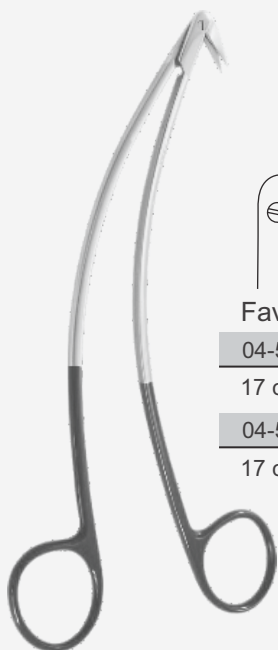

**Favaloro**

04-523-08S 8 mm

17 cm - 6 3/4"

04-523-12S 12 mm

17 cm - 6 3/4"

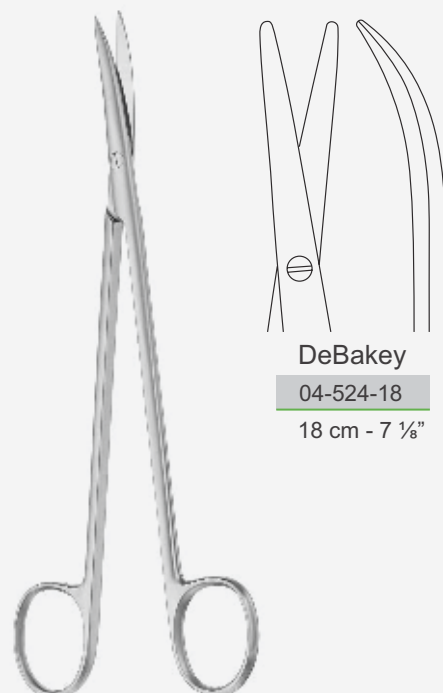

**DeBakey**

04-524-18

18 cm - 7 1/8"

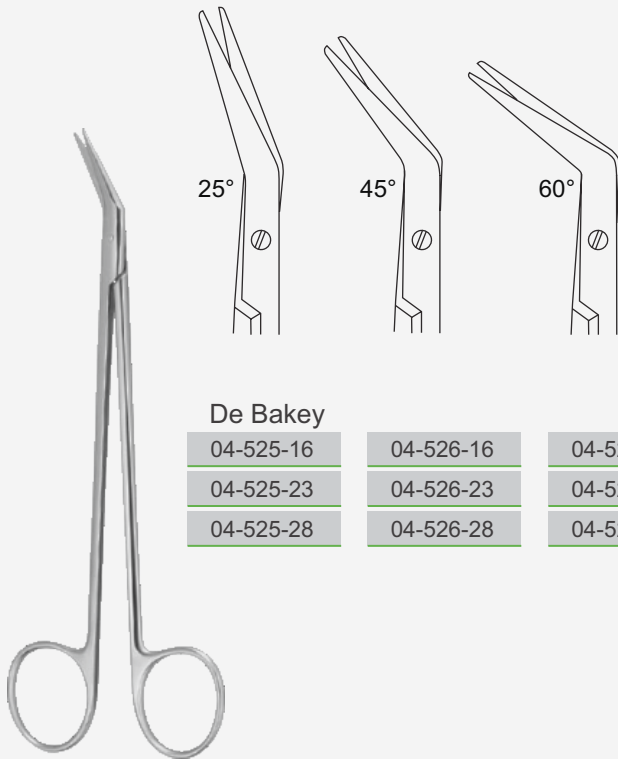

25°

45°

60°

**De Bakey**

04-525-16	04-526-16	04-527-16	16 cm - 6 ¼"
04-525-23	04-526-23	04-527-23	23 cm - 9"
04-525-28	04-526-28	04-527-28	28 cm - 11"

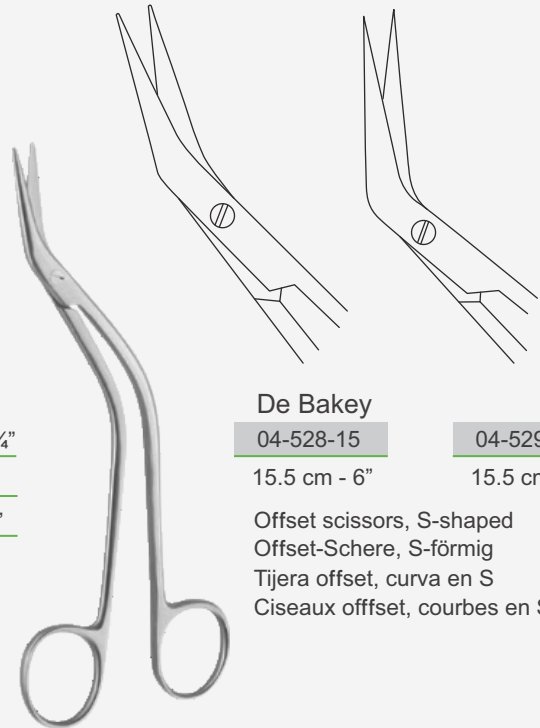

**De Bakey**

04-528-15	04-529-15
15.5 cm - 6"	15.5 cm - 6"

Offset scissors, S-shaped  
Offset-Schere, S-förmig  
Tijera offset, curva en S  
Ciseaux offset, courbes en S



25°

45°

60°

**De Bakey**

04-530-16T	04-531-16T	04-532-16T	16 cm - 6 ¼"
04-530-23T	04-531-23T	04-532-23T	23 cm - 9"
04-530-28T	04-531-28T	04-532-28T	28 cm - 11"

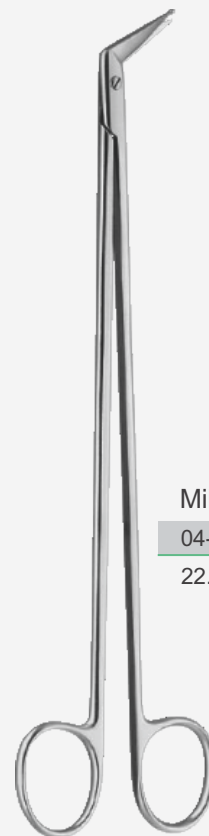

**Mills**

04-533-22
22.5 cm - 8 ¾"

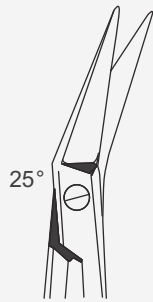

25°  
**Potts-de Martel**  
 04-534-19

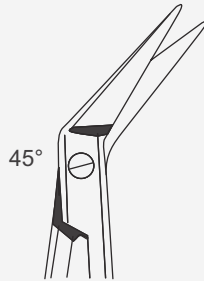

45°  
 04-535-19

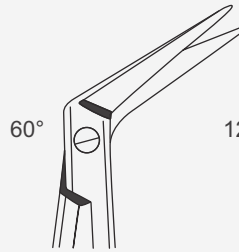

60°  
 04-536-19



125°  
 04-537-19 19 cm - 7 1/2"

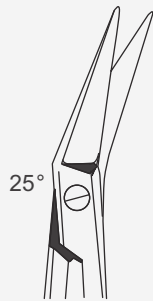

25°  
**Potts- de Martel**  
 04-538-19T

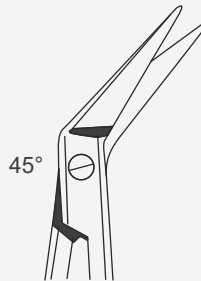

45°  
 04-539-19T

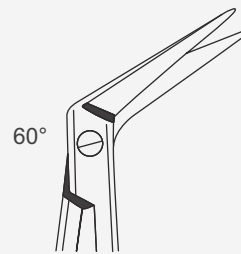

60°  
 04-540-19T 19 cm - 7 1/2 "

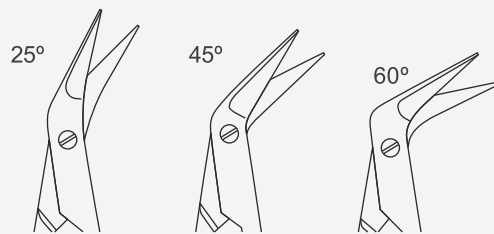

Hegemann - Diethrich

04-541-12	04-542-12	04-543-12	12 cm - 4 ¾"	12 mm
04-541-14	04-542-14	04-543-14	14 cm - 5 ½"	14 mm
04-544-12T	04-545-12T	04-546-12T	12 cm - 4 ¾"	12 mm
04-544-14T	04-545-14T	04-546-14T	14 cm - 5 ½"	14 mm
04-547-12S	04-548-12S	04-549-12S	12 cm - 4 ¾"	12 mm
04-547-14S	04-548-14S	04-549-14S	14 cm - 5 ½"	14 mm

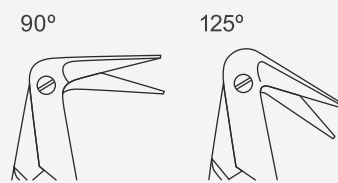

04-550-12	04-551-12	12 cm - 4 ¾"	12 mm
04-550-14	04-551-14	14 cm - 5 ½"	14 mm
04-552-12T	04-553-12T	12 cm - 4 ¾"	12 mm
04-552-14T	04-553-14T	14 cm - 5 ½"	14 mm
04-554-12S	04-553-12S	12 cm - 4 ¾"	12 mm
04-554-14S	04-553-14S	14 cm - 5 ½"	14 mm



Potts - De Martel

04-560-18



04-561-18

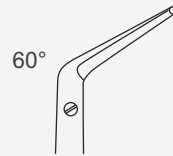

04-562-18

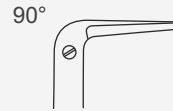

04-563-18



04-564-18

18 cm - 7"



04-565-18



04-566-18

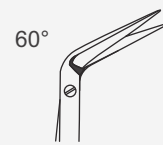

04-567-18



04-568-18



04-569-18

18 cm - 7"



Hegemann-Diethrich

04-570-18

18 cm - 7"



Mattox-Potts

04-571-14

14 cm - 5 1/2"

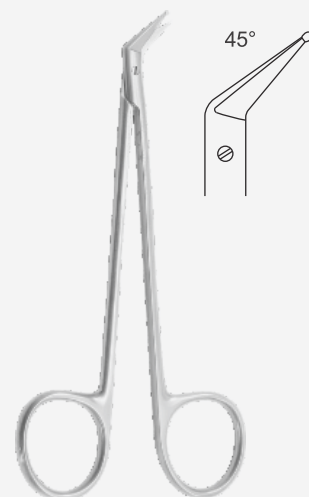

Hegemann

04-572-13

13 cm - 5"

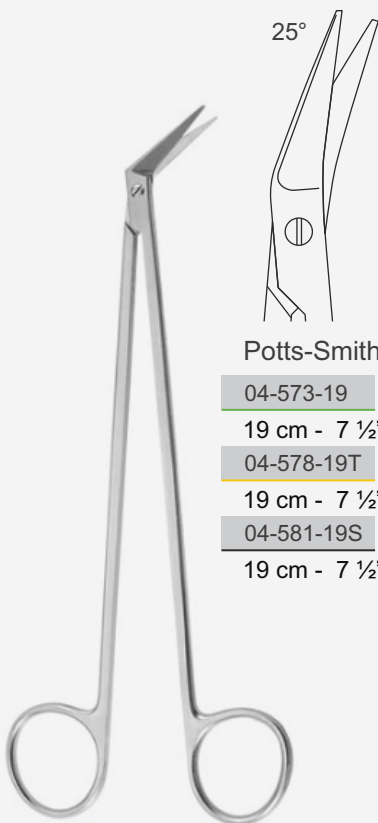

Potts-Smith

04-573-19

19 cm - 7 1/2"

04-578-19T

19 cm - 7 1/2"

04-581-19S

19 cm - 7 1/2"

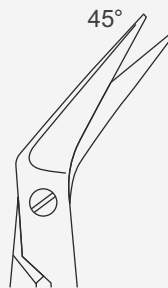

04-574-19

19 cm - 7 1/2"

04-579-19T

19 cm - 7 1/2"

04-582-19S

19 cm - 7 1/2"

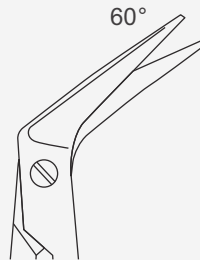

04-575-19

19 cm - 7 1/2"

04-580-19T

19 cm - 7 1/2"

04-583-19S

19 cm - 7 1/2"

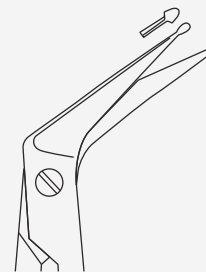

04-576-19

19 cm - 7 1/2"

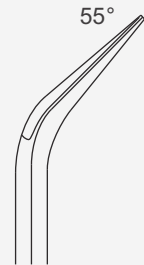

04-577-19

19 cm - 7 1/2"

1 blade ball-tipped, 60°  
1 Blatt geknöpft, 60°  
1 hoja con punta de bola, 60°  
1 lame à pointe bille, 60°

Cartilage scissors  
 Knorpelscheren  
 Tijeras para cartilagos  
 Ciseaux pour cartilages  
 forbici cartilagine

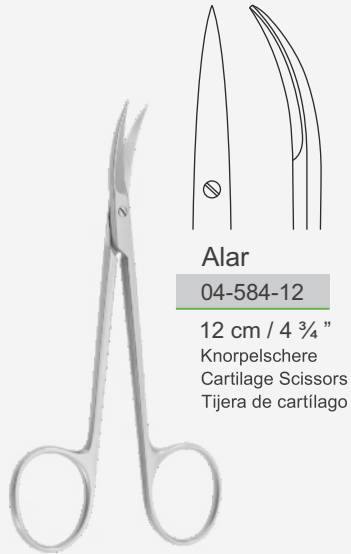

**Alar**

04-584-12

12 cm / 4 ¾"

Knorpelschere  
 Cartilage Scissors  
 Tijera de cartilago



**Martin-Cartilage**

04-589-19

19 cm - 7 ½"

curved, sawedge  
 gebogen, gezahnt  
 curva, dentada  
 courbes, dentelés

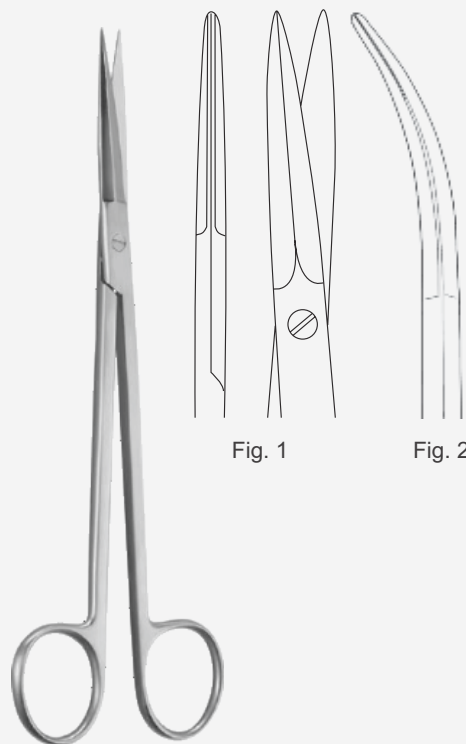

Fig. 1

Fig. 2

**Mc Indoe**

04-590-01 Fig. 1

04-590-02 Fig. 2

19 cm - 7 ½"



**Potts-Smith**

04-591-19

19 cm - 7 ½"





**Boettcher**  
04-592-18  
18 cm - 7"

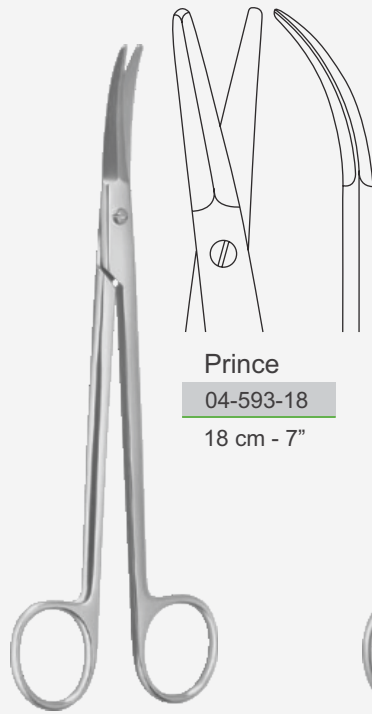

**Prince**  
04-593-18  
18 cm - 7"



**Toennis**  
04-594-18  
18 mm - 7"  
fine  
fein  
multa  
amende



04-595-18  
18 mm - 7"  
fine  
fein  
multa  
amende



04-596-18  
18 mm - 7"  
very fine  
sehr fein  
muy fino  
très bien



**Toennis-Adson**  
04-597-17  
17.5 cm - 7 3/4"  
fine  
fein  
multa  
amende



04-598-17  
17.5 cm - 7 3/4"  
very fine  
sehr fein  
muy fino  
très bien



**Toennis-Adson**  
04-599-17T  
17.5 cm - 7 3/4"  
04-601-17S  
17.5 cm - 7 3/4"  
fine  
fein  
multa  
amende



04-600-17T  
17.5 cm - 7 3/4"  
04-602-17S  
17.5 cm - 7 3/4"  
very fine  
sehr fein  
muy fino  
très bien

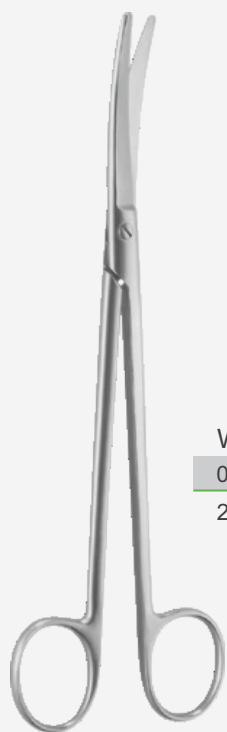

**Wertheim**  
 04-603-20  
 20 cm - 8"

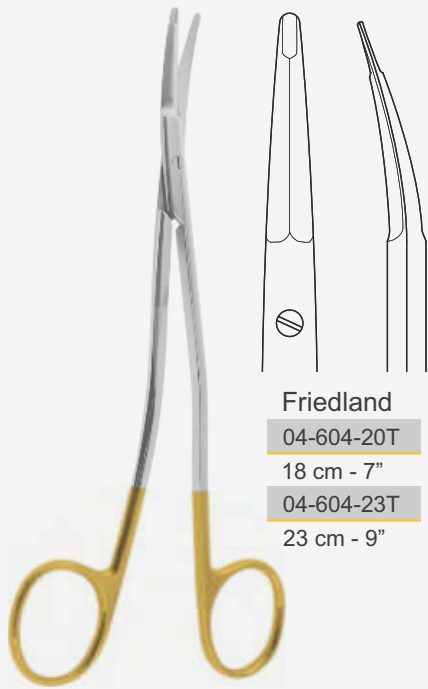

**Friedland**  
 04-604-20T  
 18 cm - 7"  
 04-604-23T  
 23 cm - 9"



**Good**  
 04-605-19  
 19 cm - 7 1/2"

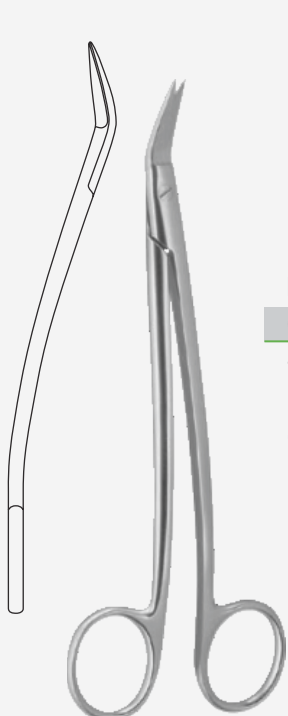

**Dean**  
 04-606-17  
 17 cm - 6 3/4"  
 curved  
 gebogen  
 curva  
 courbes

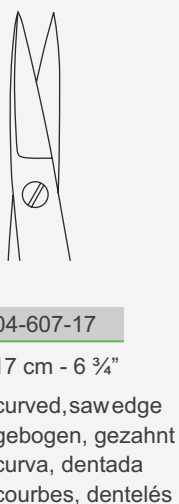

**Dean**  
 04-607-17  
 17 cm - 6 3/4"  
 curved, sawedge  
 gebogen, gezahnt  
 curva, dentada  
 courbes, dentelés

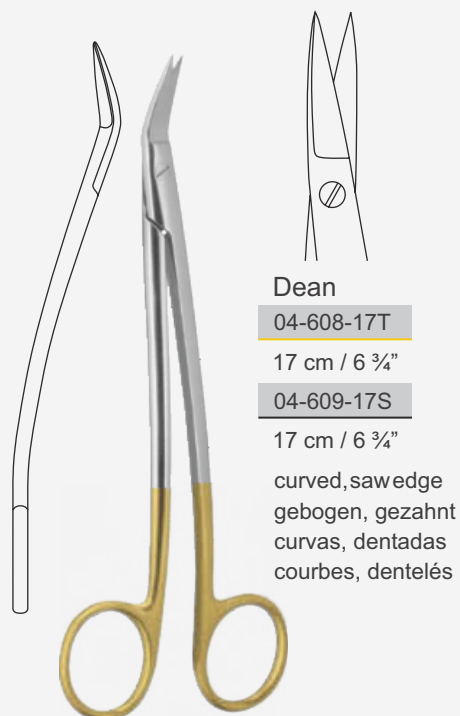

**Dean**  
 04-608-17T  
 17 cm / 6 3/4"  
 04-609-17S  
 17 cm / 6 3/4"  
 curved, sawedge  
 gebogen, gezahnt  
 curvas, dentadas  
 courbes, dentelés



**Crafoord**  
04-610-30  
30 cm - 12"

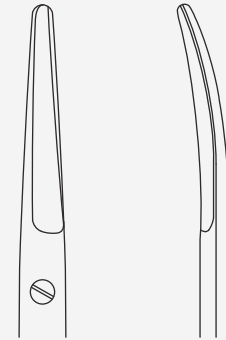

**Willauer**  
04-611-25  
04-611-28

straight  
gerade  
recta  
droits

04-612-25 25 cm - 9 3/4"  
04-612-28 28 cm - 11"

curved  
gebogen  
curva  
courbes

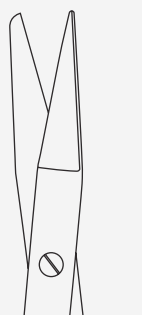

**Resano**  
04-613-25  
25 cm - 10"



04-614-25S  
25 cm - 10"

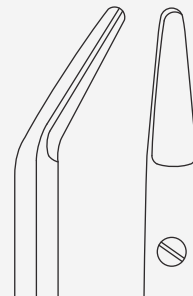

**Finochietto**  
04-615-27  
27 cm - 10 1/2"

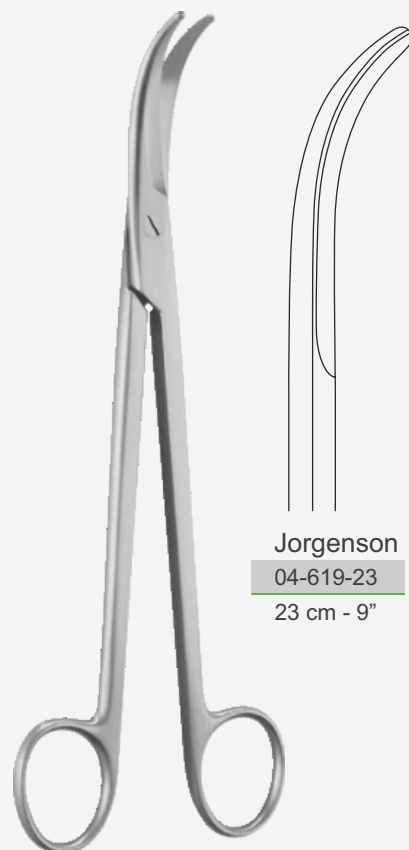
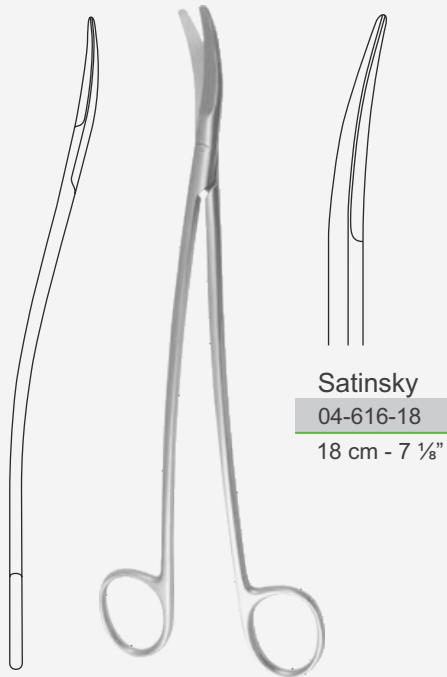

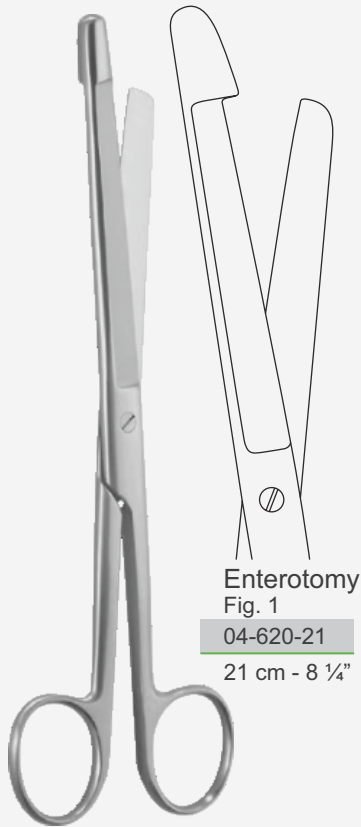

Enterotomy  
Fig. 1  
04-620-21  
21 cm - 8 1/4"

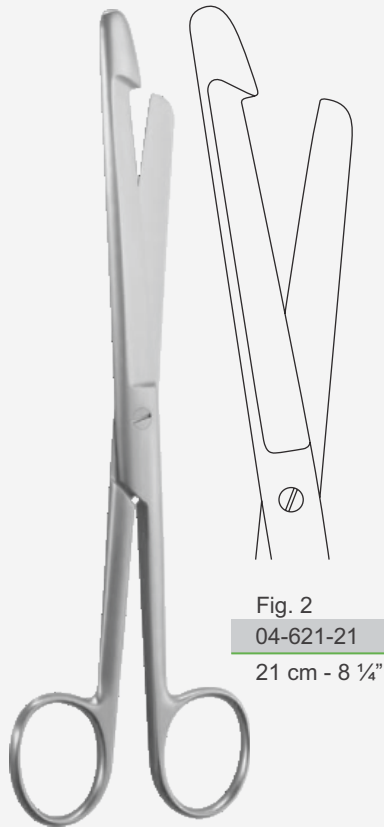

Fig. 2  
04-621-21  
21 cm - 8 1/4"

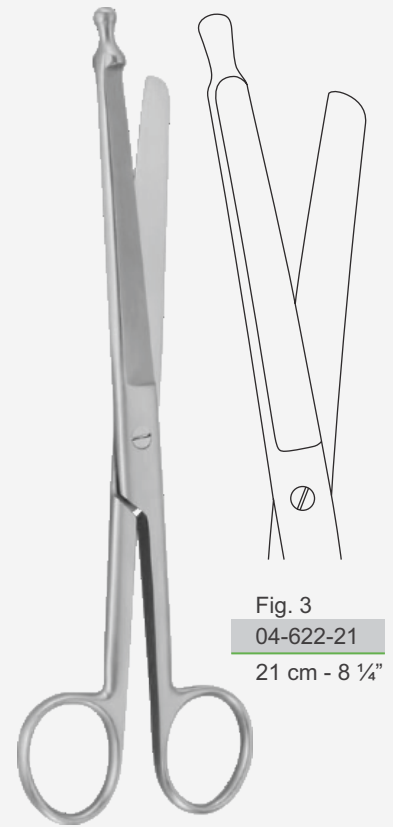

Fig. 3  
04-622-21  
21 cm - 8 1/4"



Stelzner  
04-623-31  
31 cm - 12 1/4"



Stelzner  
04-624-32  
32.5 cm - 12 3/4"  
Heavy curve



Lloyd-Davies  
(Goligher's)  
04-625-27  
27 cm - 10 1/2"



**Busch**

04-626-13	04-627-13	13 cm - 5"
04-626-16	04-627-16	16 cm - 6 ¼"
04-628-16T	04-629-16T	16 cm - 6 ¼"

sawedge  
 gezahnt  
 dentada  
 dentelés

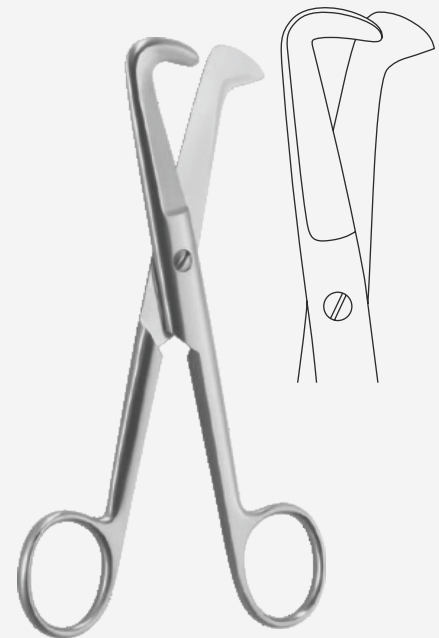

**Schumacher**

04-629-16	16 cm - 6 ¼"
-----------	--------------



**USA Model**

04-630-10	10.5 cm - 4 ¼"
-----------	----------------

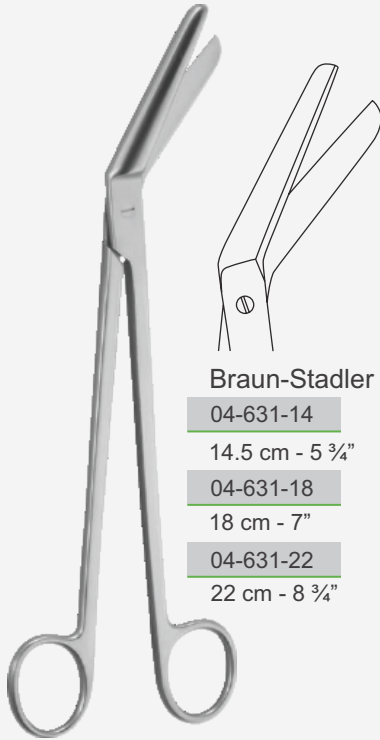

**Braun-Stadler**

04-631-14

14.5 cm - 5 ¾"

04-631-18

18 cm - 7"

04-631-22

22 cm - 8 ¾"



**Waldmann**

04-632-20

20 cm - 8"

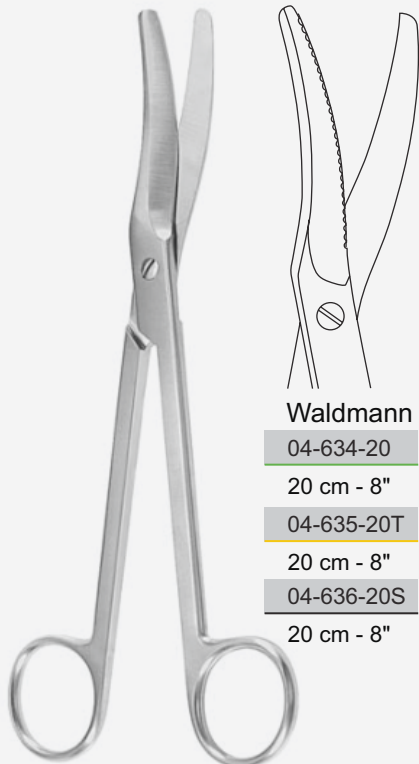

**Waldmann - Modified**

04-634-20

20 cm - 8"

04-635-20T

20 cm - 8"

04-636-20S

20 cm - 8"

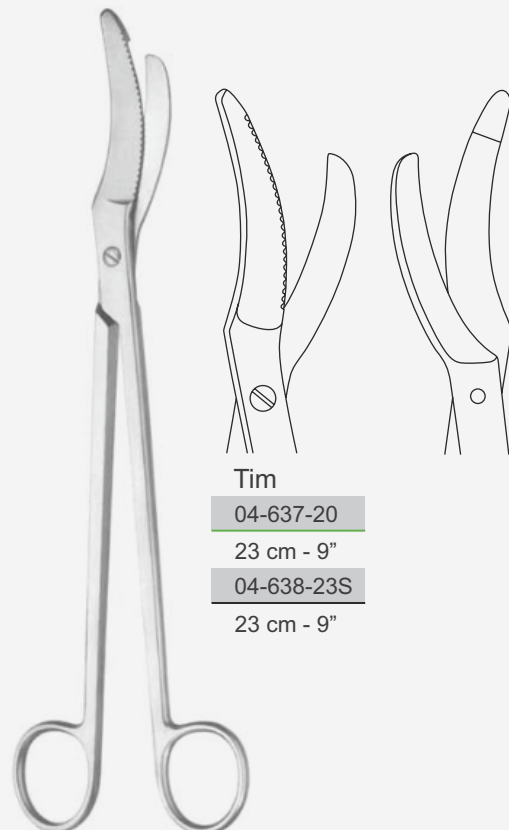

**Tim**

04-637-20

23 cm - 9"

04-638-23S

23 cm - 9"

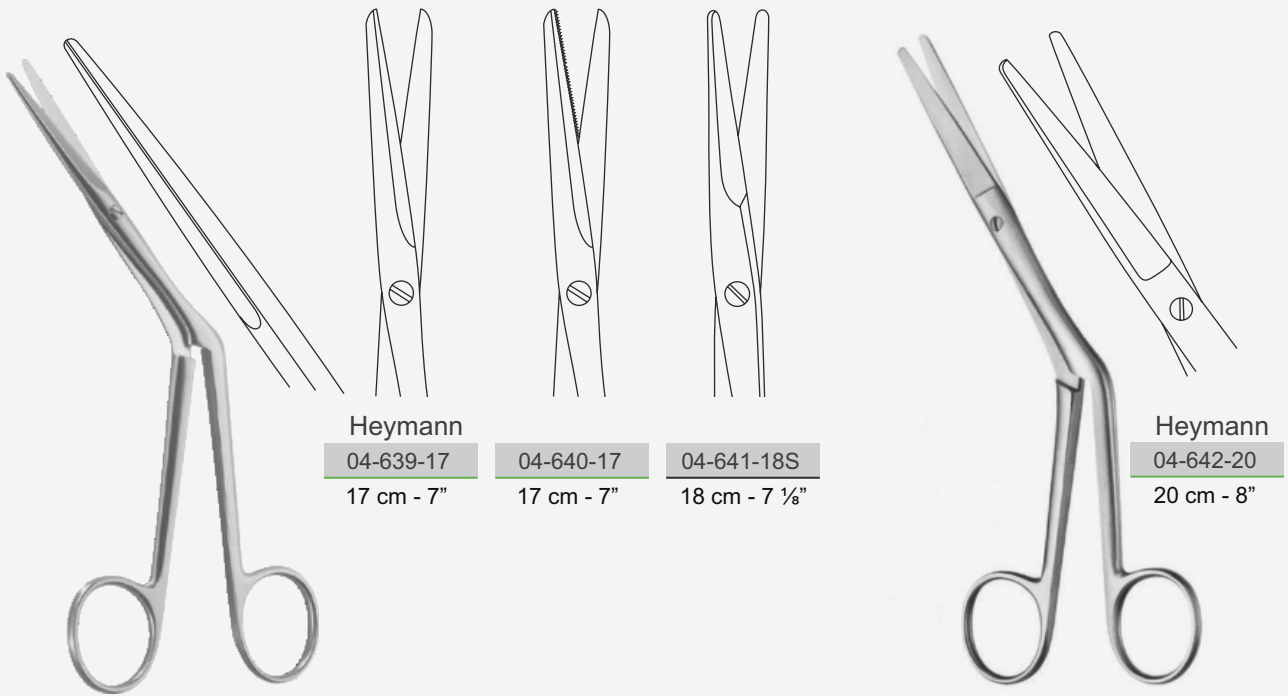

Heymann

04-639-17

17 cm - 7"

04-640-17

17 cm - 7"

04-641-18S

18 cm - 7 1/8"

Heymann

04-642-20

20 cm - 8"

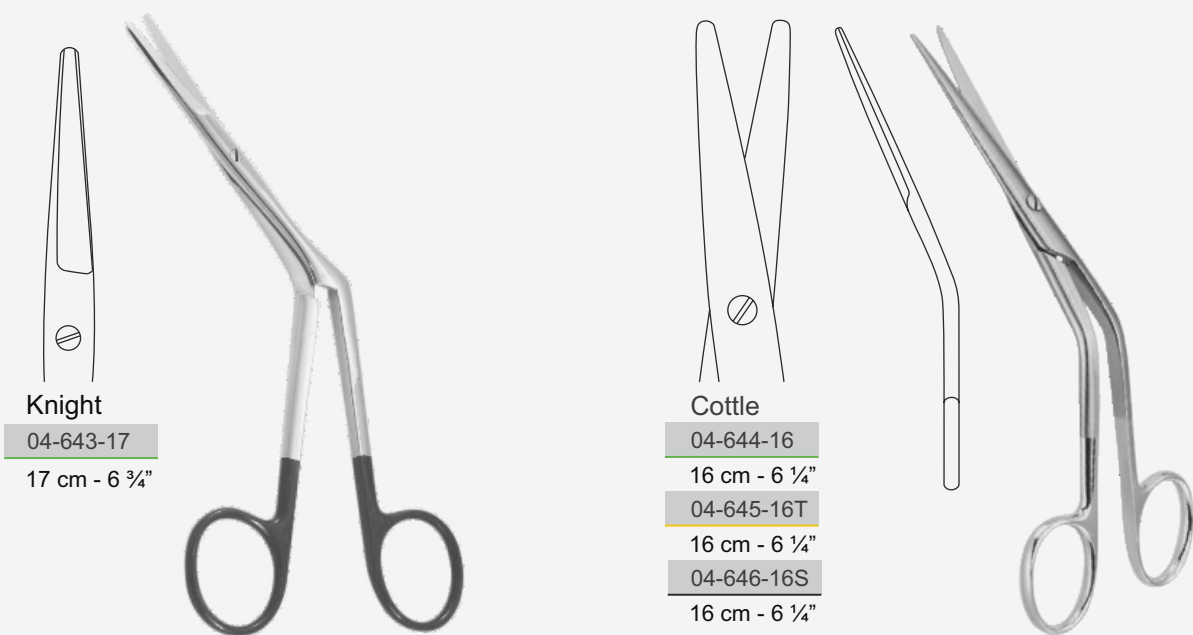

Knight

04-643-17

17 cm - 6 3/4"

Cottle

04-644-16

16 cm - 6 1/4"

04-645-16T

16 cm - 6 1/4"

04-646-16S

16 cm - 6 1/4"





**Fomon**  
04-647-15  
15 cm - 6"

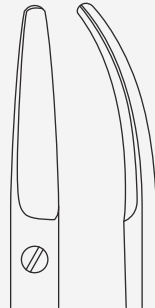

04-648-13  
13 cm - 5"

04-649-13T

13 cm - 5"

04-650-13S

13 cm - 5"



04-651-14  
14.5 cm - 5 ¾"

serrated  
gezahnt  
serrado  
denté



04-652-13  
13.5 cm - 5 ¼"

light curved  
leicht gebogen  
ligeramente curvada  
légèrement incurvé

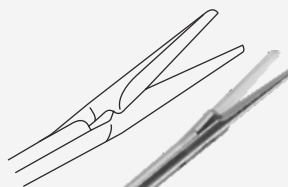

**Olivecrona**  
04-652-23  
23 cm - 9"  
Trigeminal scissors  
Trigeminusschere  
Tijera para nervio trigémino  
Ciseaux pour le trigéminus

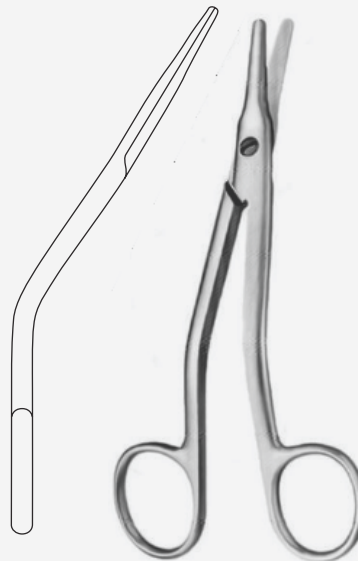

**Walter-Cottle**  
04-653-16T  
16 cm - 6 ¼"  
04-654-16S  
16 cm - 6 ¼"

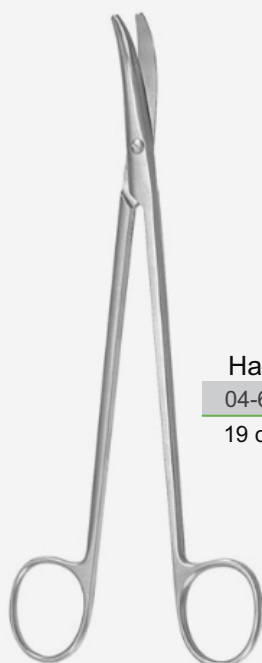

**Halle**  
 04-655-19  
 19 cm - 7 1/2"



**Sailer**  
 04-656-17  
 17 cm - 6 3/4"



**Wilkinson**  
 04-657-19  
 19 cm - 7 1/2"



**Fanous**  
 04-658-14  
 14 cm - 5 1/2"  
 04-659-14S  
 14 cm - 5 1/2"



**Obwegeser**  
 04-660-18  
 18.5 cm - 7 1/4"  
 04-660-20  
 20 cm - 8"

Undermining scissors  
 Unterminierscheren  
 Ciseaux à tunnellation  
 Tijeras para tunelización



**Fomon**  
 04-661-12  
 12.5 cm - 5"  
 both sides sharp  
 beidseitig schneidend  
 coupant des deux côtés  
 cortantes por ambos lados

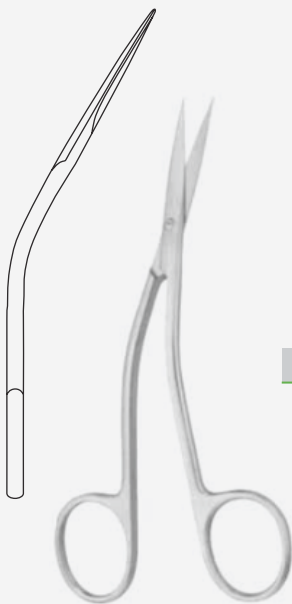

**Hough**

04-662-13

13 cm - 5 1/8"

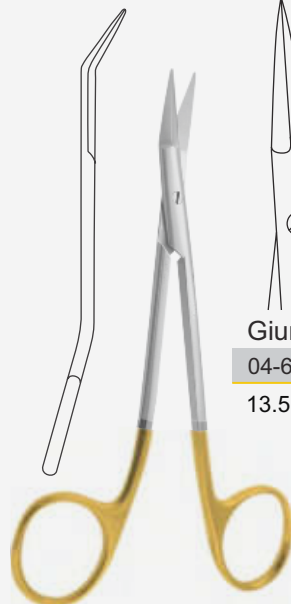

**Giunta**

04-663-13T

13.5 cm - 5 3/8"

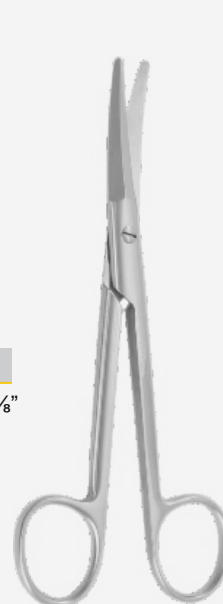

**Aufricht**

04-664-14

14 cm - 5 1/2"

04-665-14T

14 cm - 5 1/2"

04-666-14S

14 cm - 5 1/2"

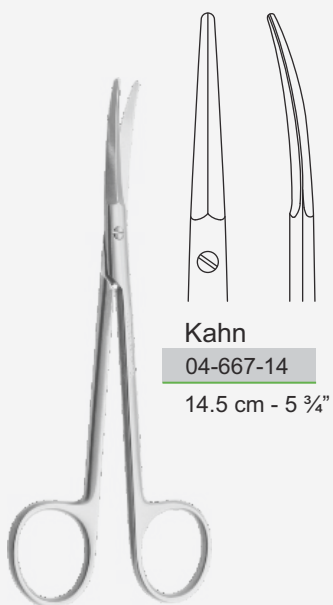
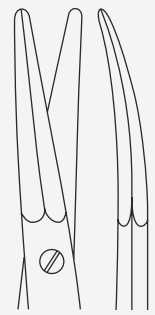

**Kahn**

04-667-14

14.5 cm - 5 3/4"

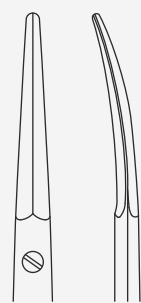

**Walter**

04-668-14

14 cm - 5 1/2"

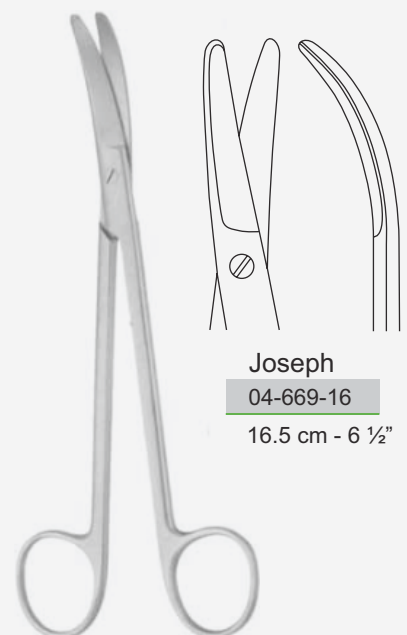

**Joseph**

04-669-16

16.5 cm - 6 1/2"

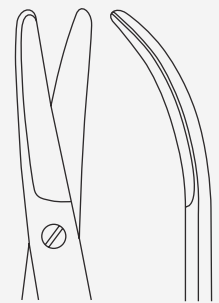

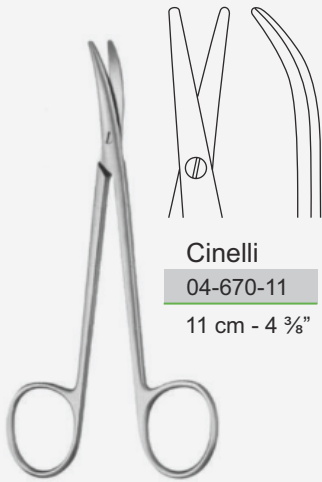

**Cinelli**

04-670-11

11 cm - 4 3/8"

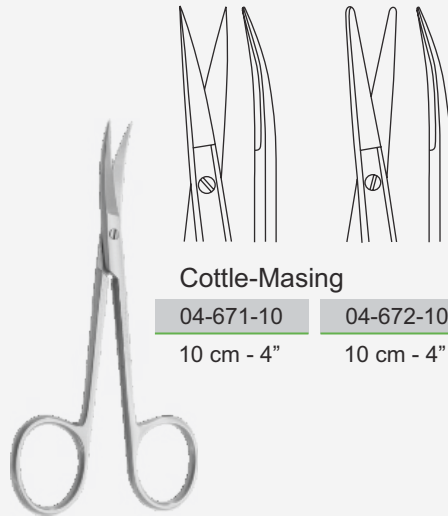

**Cottle-Masing**

04-671-10

10 cm - 4"

04-672-10

10 cm - 4"

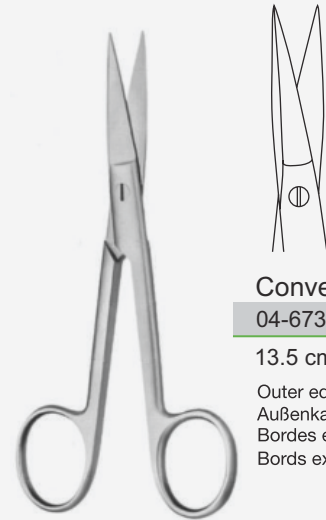

**Converse**

04-673-13

13.5 cm - 5 3/8"

Outer edges semisharp  
 Außenkanten halbscharf  
 Bordes exteriores semicortantes  
 Bords extérieurs semi-tranchants



**Cottle**

04-674-11

11.5 cm - 4 1/2"

Bulldog scissors  
 Bulldogschere  
 Tijera Bulldog  
 Ciseaux Bulldog

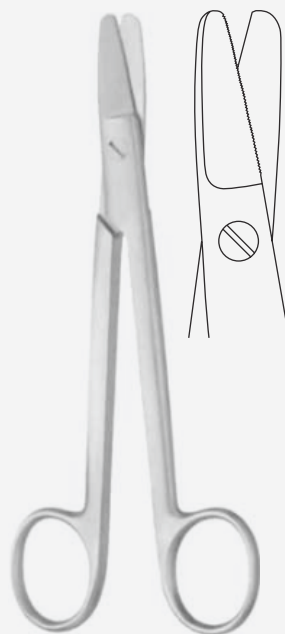

**Castanares**

04-675-16

16 cm - 6 1/4"

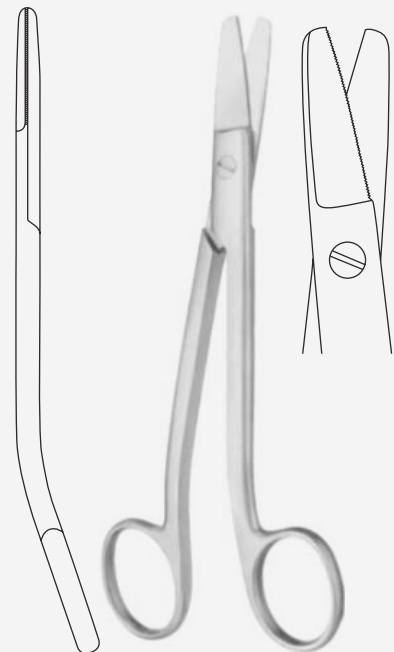

**Walter-Castanares  
 Facelift**

04-676-16

16 cm - 6 1/4"

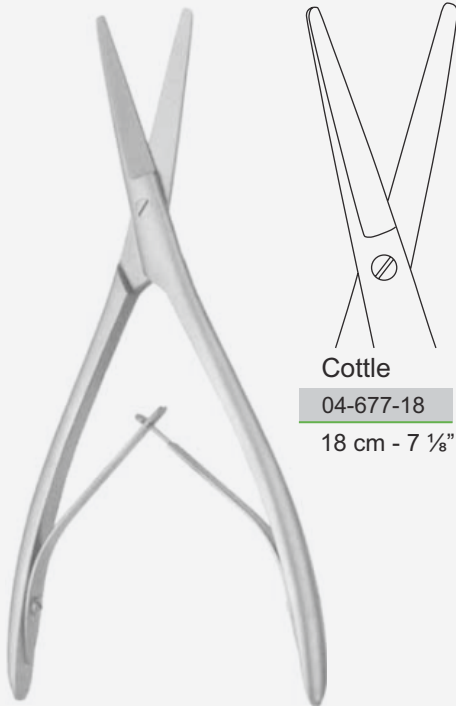

Cottle

04-677-18

18 cm - 7 1/8"

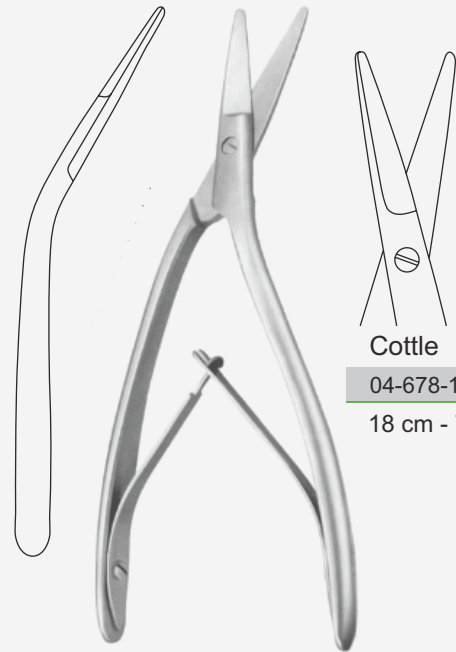

Cottle

04-678-18

18 cm - 7 1/8"

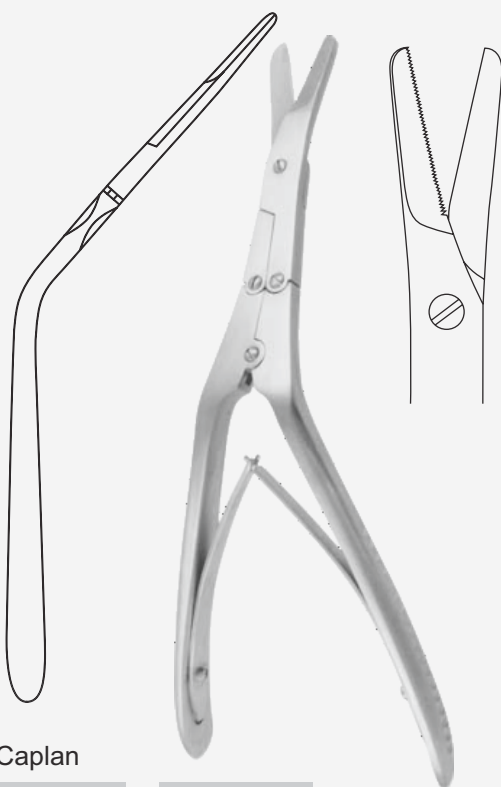

Caplan

04-679-22

22 cm - 8 5/8"

04-681-22T

22 cm - 8 5/8"

straight  
gerade  
recta  
droits

04-680-22

22 cm - 8 5/8"

04-682-22T

22 cm - 8 5/8"

curved  
gebogen  
curva  
courbes

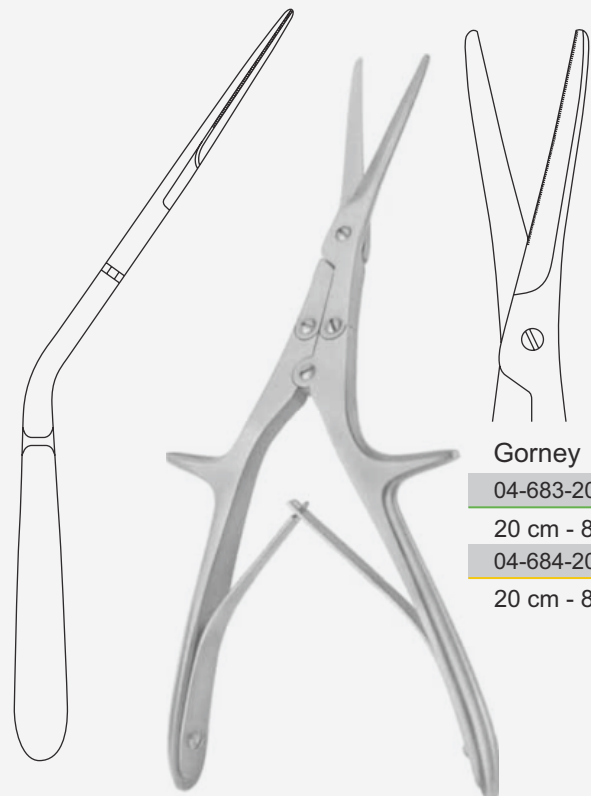

Gorney



04-683-20

20 cm - 8"

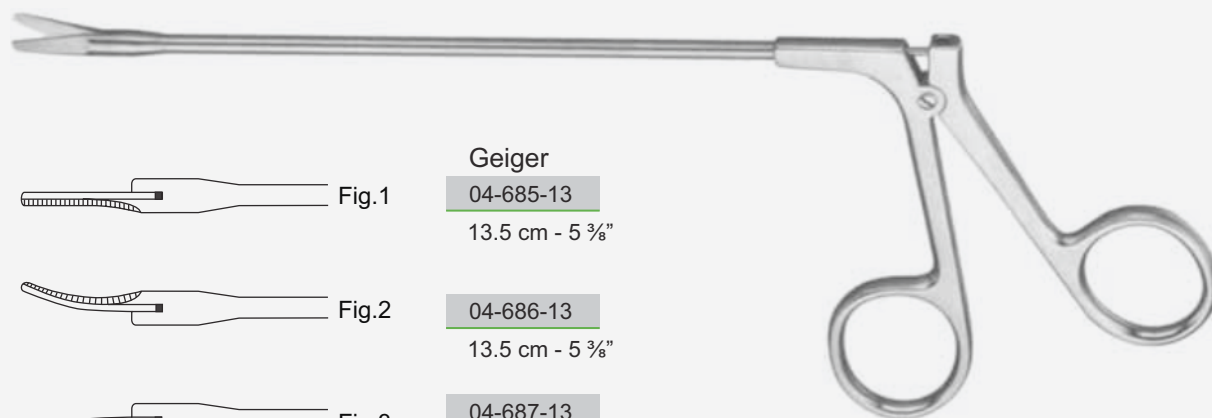

04-684-20T

20 cm - 8"

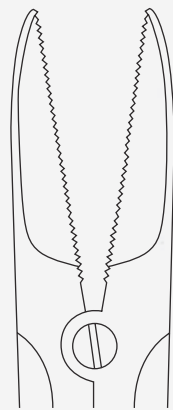
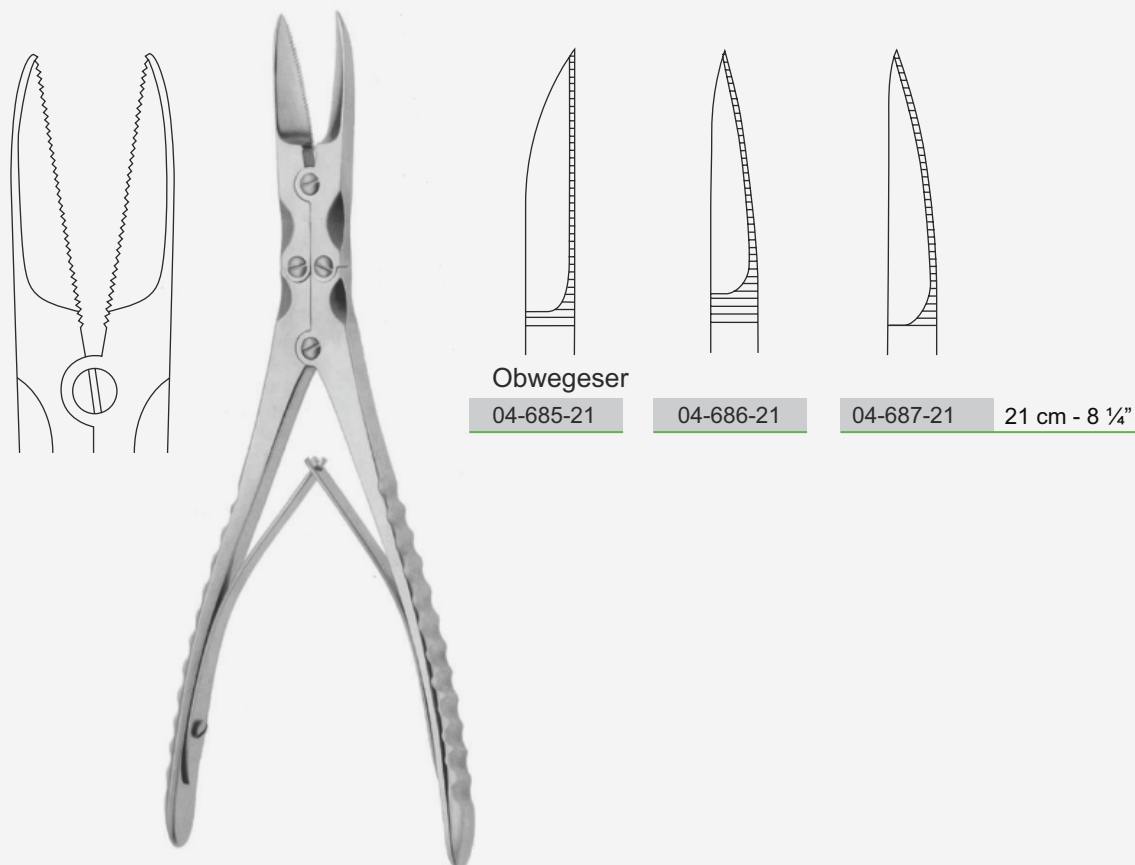

-  Fig.1 **04-685-13**  
 13.5 cm - 5 3/8"
-  Fig.2 **04-686-13**  
 13.5 cm - 5 3/8"
-  Fig.3 **04-687-13**  
 13.5 cm - 5 3/8"

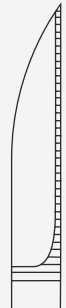

-  **04-685-21**
  -  **04-686-21**
  -  **04-687-21**
- Obwegeser**  
 21 cm - 8 1/4"



Iris

04-688-09	04-689-09	04-690-11	04-691-11	04-692-11	04-693-11
9 cm - 3 1/2"	9 cm - 3 1/2"	11.5 cm - 4 1/2"	11.5 cm - 4 1/2"	11.5 cm - 4 1/2"	11.5 cm - 4 1/2"
04-688-10	04-689-10				
10.5 cm - 4 1/8"	10.5 cm - 4 1/8"				
04-688-11	04-689-11				
11.5 cm - 4 1/2"	11.5 cm - 4 1/2"				
04-688-12	04-689-12				
12 cm - 4 3/4"	12 cm - 4 3/4"				



Micro-Iris

04-700-09	04-701-09
9 cm - 3 1/2"	9 cm - 3 1/2"
	04-702-09S
	9 cm - 3 1/2"

Iris

04-694-11T	04-695-11T	04-696-11T	11.5 cm - 4 1/2"
04-697-10S	04-698-10S	04-699-10S	10.5 cm - 4 1/8"
04-697-11S	04-698-11S	04-699-11S	11.5 cm - 4 1/2"
04-697-13S	04-698-13S	04-699-13S	13 cm - 5 1/8"

straight	curved	angular
gerade	gebogen	kniegebogen
recta	curva	acodada
droits	courbes	coudés



Iris

04-703-11	04-704-11	04-705-11	04-706-11	11.5 cm / 4 1/2"
04-707-10	04-708-10	04-709-10	04-710-10S	10.5 cm / 4 1/8"
04-707-11	04-708-11	04-709-11	04-710-11S	11.5 cm / 4 1/2"

straight	curved	angular	laterally curved
gerade	gebogen	kniegebogen	seitwärts gebogen
recta	curva	acodada	curva lateral
droits	courbes	coudés	courbes laterale

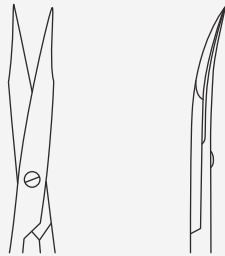

Stevens

04-711-10	04-712-10	10 cm - 4"
04-711-11	04-712-11	11 cm - 4 ¼"
04-713-11T	04-714-11T	11 cm - 4 ¼"
04-715-10S	04-716-10S	10 cm - 4"
04-715-11S	04-716-11S	11 cm - 4 ¼"
04-715-13S	04-716-13S	13.5 cm - 5 ¼"

sharp, sharp  
 spitz, spitz  
 aguda, aguda  
 pointue, pointue

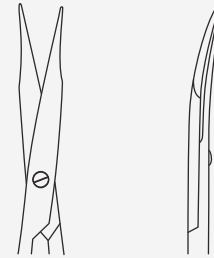

Stevens

04-717-10	04-718-10	10 cm - 4"
04-717-11	04-718-11	11 cm - 4 ¼"
04-719-11T	04-720-11T	11 cm - 4 ¼"
04-721-10S	04-722-10S	10 cm - 4"
04-721-11S	04-722-11S	11 cm - 4 ¼"
04-721-13S	04-722-13S	13.5 cm - 5 ¼"

blunt, blunt  
 stumpf, stumpf  
 roma, roma  
 mousse, mousse



Stevens

04-723-18	18 cm - 7"
04-723-18S	18 cm - 7"



Stevens

04-724-11	11 cm - 4 ½"
-----------	--------------

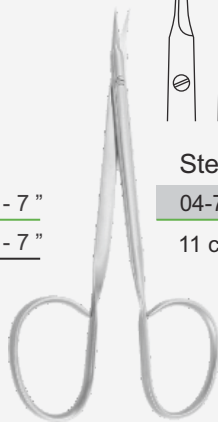

Walton

04-725-10	10 cm - 4"
-----------	------------

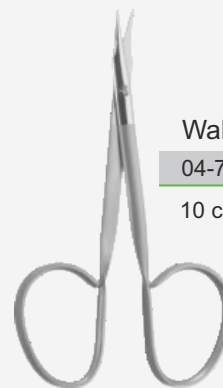

Graefe

04-726-10	10.5 cm - 4 ¼"
-----------	----------------





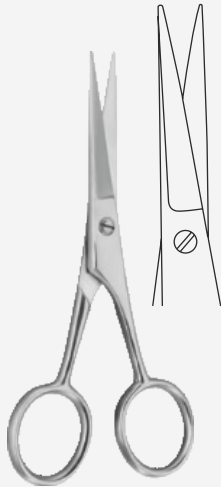

Carlos - Modified

04-727-11

04-727-13

04-727-14

Fig. 1



04-728-11 11.5 cm - 4 ½"

04-728-13 13 cm - 5"

04-728-14 14 cm - 5 ½"

Fig. 2

Nail splitting scissors  
Nagelspaltscheren  
Tijeras para uñas  
Ciseaux à ongles  
Forbici chiodo scissione

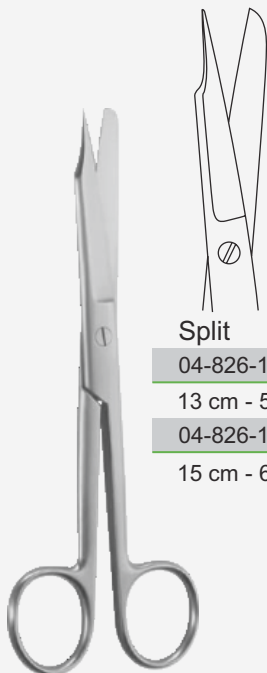

Split

04-826-13

13 cm - 5"

04-826-15

15 cm - 6"



Systrunk

04-827-13

13 cm - 5"

straight  
gerade  
recta  
droits

04-827-15

13 cm - 5"

curved  
gebogen  
curva  
courbes

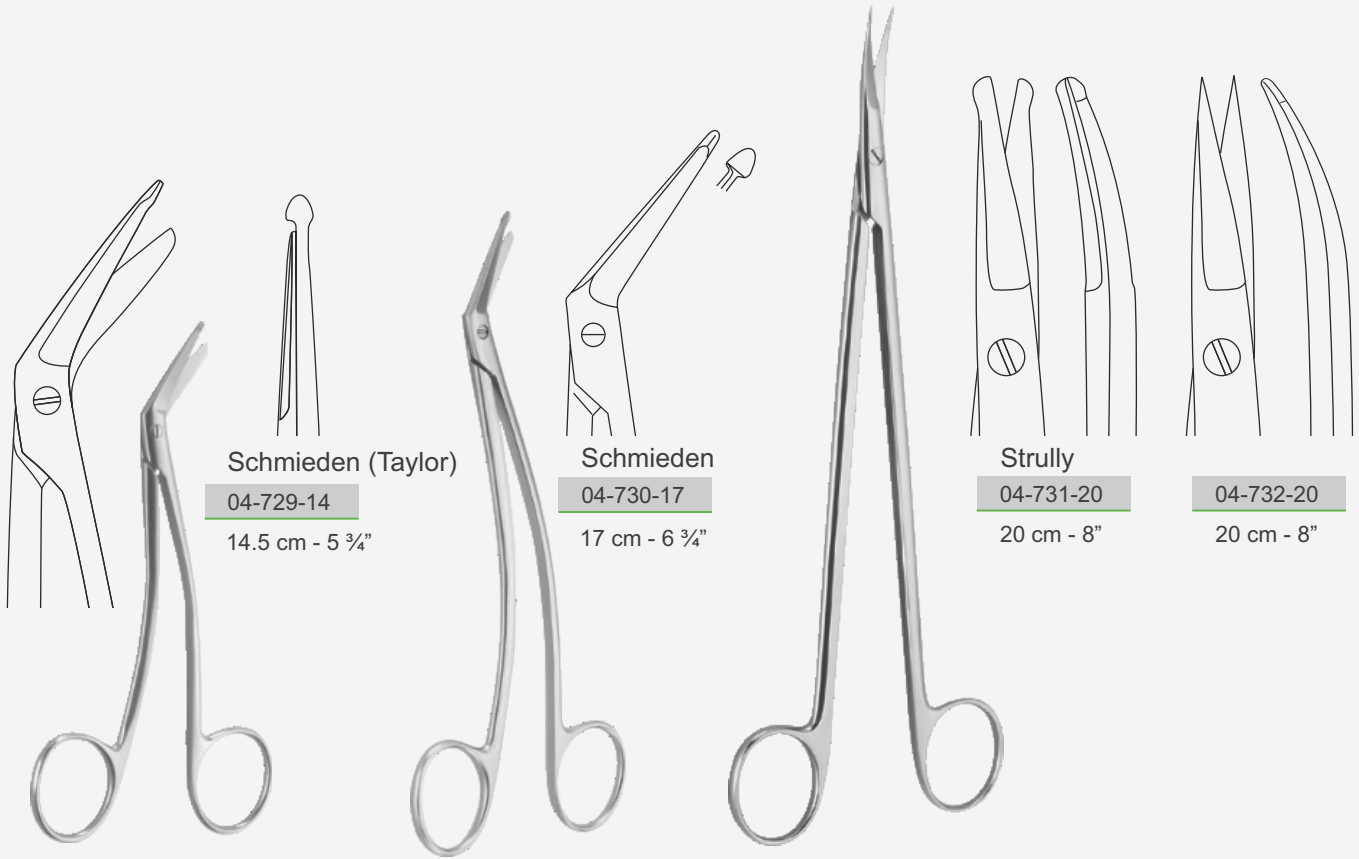

Schmieden (Taylor)

04-729-14

14.5 cm - 5 ¾"

Schmieden

04-730-17

17 cm - 6 ¾"

Strully

04-731-20

20 cm - 8"

04-732-20

20 cm - 8"



Taylor

04-733-14

14 cm - 5 ½"

Dandy

04-734-17

17 cm - 6 ¾"

04-734-19

19 cm - 7 ½"



Littauer

04-735-14

14 cm - 5 1/2"



O'Brien

04-736-09

9 cm - 3 1/2"



Spencer

04-737-09

9 cm - 3 1/2"

04-737-10

10.5 cm - 4 1/4"

04-737-11

11.5 cm - 4 1/2"

04-737-13

13 cm - 5"

straight  
gerade  
recta



04-738-09

9 cm - 3 1/2"

04-738-10

10.5 cm - 4 1/4"

04-738-11

11.5 cm - 4 1/2"

04-738-13

13 cm - 5"

curved to side  
seitlich gebogen  
curva de lado

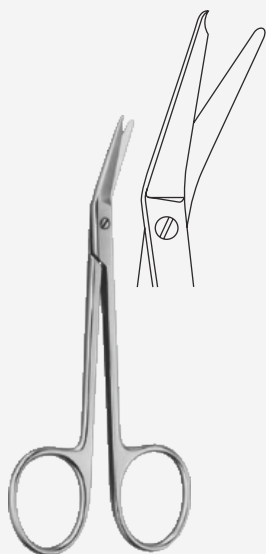

Spencer Angled

04-739-11

11.5 cm - 4 1/2"

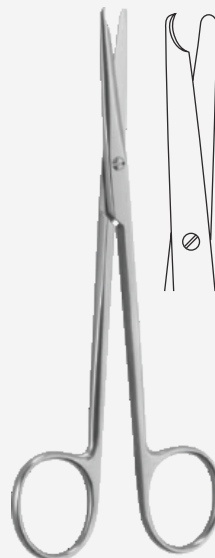

Buck

04-740-14

14.5 cm - 5 3/4"

04-740-18

18 cm - 7"

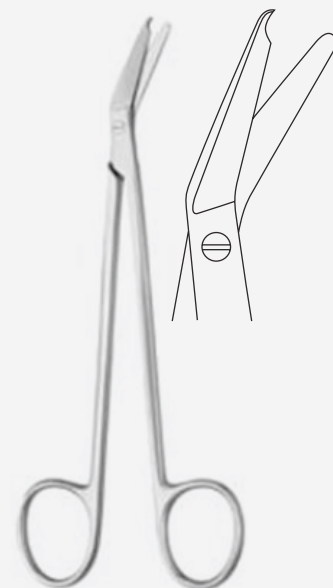

Locklin

04-742-15

15 cm - 6"

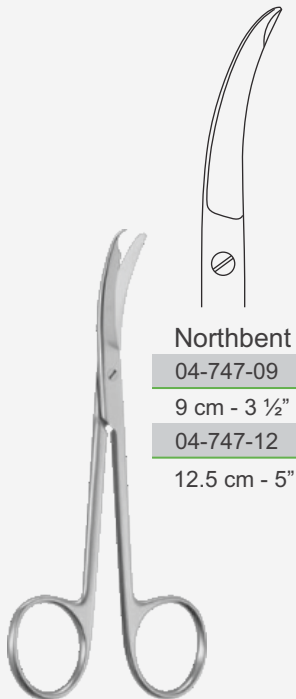

**Northbent**  
 04-747-09  
 9 cm - 3 1/2"  
 04-747-12  
 12.5 cm - 5"

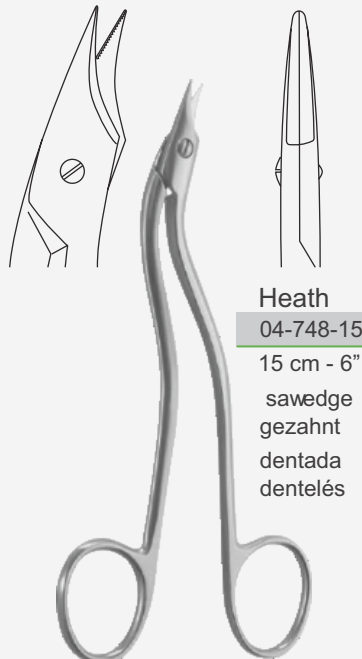

**Heath**  
 04-748-15  
 15 cm - 6"  
 saw edge  
 gezahnt  
 dentada  
 dentelés



**Bob**  
 04-749-12  
 12 cm - 4 3/4"  
 saw edge  
 gezahnt  
 dentada  
 dentelés

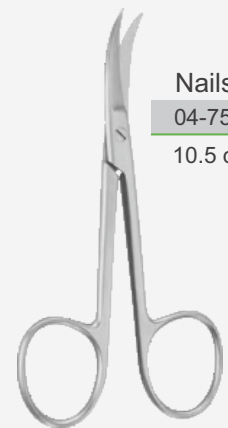

**Nails**  
 04-751-10  
 10.5 cm - 4 1/4"



**Eiselsberg**  
 04-750-11  
 11 cm - 4 1/4"  
 one blade serrated  
 eine Schneide gezahnt  
 une lame dentelée  
 una hoja dentada



**Spencer**  
 04-120-11  
 11 cm - 4 1/4"



04-121-14  
 14.5 cm - 5 3/4"



04-122-11  
 11 cm - 4 1/4"

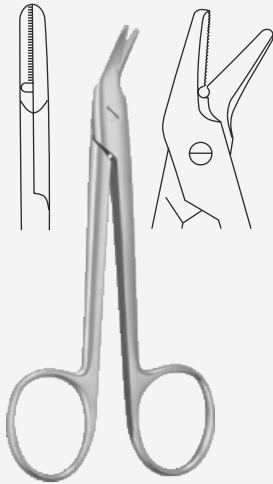

Universal  
04-753-12

12 cm / 4 3/4"

sawedge  
gezahnt  
dentada  
dentalés

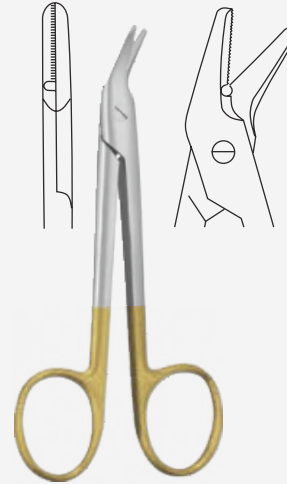

Universal  
04-754-12T

12 cm / 4 3/4"



Harvey  
04-756-12

12.5 cm / 5"

sawedge  
gezahnt  
dentada  
dentalés

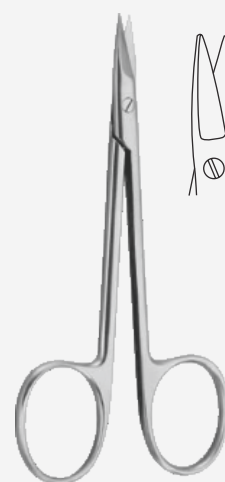

Schuhknecht  
04-757-12

12.5 cm / 5"

sawedge  
gezahnt  
dentada  
dentalés



Beebee

04-761-10

04-761-12

blunt – blunt  
 stumpf – stumpf  
 roma – roma  
 mousse – mousse



04-762-10

04-762-12

sharp – sharp  
 spitz – spitz  
 aguda – aguda  
 pointue – pointue



04-763-10

04-763-12

blunt – blunt, saw edge  
 stumpf – stumpf, gezahnt  
 roma – roma, dentada  
 mousse – mousse, dentelée



04-764-10

04-764-12

sharp – sharp, saw edge  
 spitz – spitz, gezahnt  
 aguda – aguda, dentada  
 pointue – pointue, dentelée

10 cm / 4"

12 cm / 4 3/4"

straight  
 gerade  
 recta  
 droits



Beebee

04-765-10

04-765-12

blunt – blunt  
 stumpf – stumpf  
 roma – roma  
 mousse – mousse



04-766-10

04-766-12

sharp – sharp  
 spitz – spitz  
 aguda – aguda  
 pointue – pointue



04-767-10

04-767-12

blunt – blunt, saw edge  
 stumpf – stumpf, gezahnt  
 roma – roma, dentada  
 mousse – mousse, dentelée



04-768-10

04-768-12

sharp – sharp, saw edge  
 spitz – spitz, gezahnt  
 aguda – aguda, dentada  
 pointue – pointue, dentelée

10 cm / 4"

12 cm / 4 3/4"

curved  
 gebogen  
 curva  
 courbes



Universal

Black	04-494-01	04-769-01	04-770-01
Blue	04-494-02	04-769-02	04-770-02
Green	04-494-03	04-769-03	04-770-03
Red	04-494-04	04-769-04	04-770-04
White	04-494-05	04-769-05	04-770-05
Orange	04-494-06	04-769-06	04-770-06
Pink	04-494-07	04-769-07	04-770-07
Yellow	04-494-08	04-769-08	04-770-08
Brown	04-494-09	04-769-09	04-770-09
Dark Red	04-769-10	04-769-10	04-770-10
Light Blue	04-494-11	04-769-11	04-770-11
Purple	04-494-12	04-769-12	04-770-12
	11 cm - 4¼"	16 cm - 6¼"	18 cm - 7"
	Autoclavable		
	Fig. 1		



Universal

Black	04-116-01	04-117-01	04-118-01
Blue	04-116-02	04-117-02	04-118-02
Green	04-116-03	04-117-03	04-118-03
Purple	04-116-04	04-117-04	04-118-04
Orange	04-116-05	04-117-05	04-118-05
Red	04-116-06	04-117-06	04-118-06
Yellow	04-116-07	04-117-07	04-118-07
	11 cm - 4¼"	16 cm - 6¼"	18 cm - 7"
	With plastic tip		
	Autoclavable		
	Fig. 2		



Snip

Blue	04-112-01	04-113-01	04-114-01
Yellow	04-112-02	04-113-02	04-114-02
Green	04-112-03	04-113-03	04-114-03
Pink	04-112-04	04-113-04	04-114-04
Orange	04-112-05	04-113-05	04-114-05
Red	04-112-06	04-113-06	04-114-06
	12 cm - 4¾"	12 cm - 4¾"	12 cm - 4¾"
	Sharp / sharp	Sharp / blunt	Blunt / blunt
	Autoclavable		

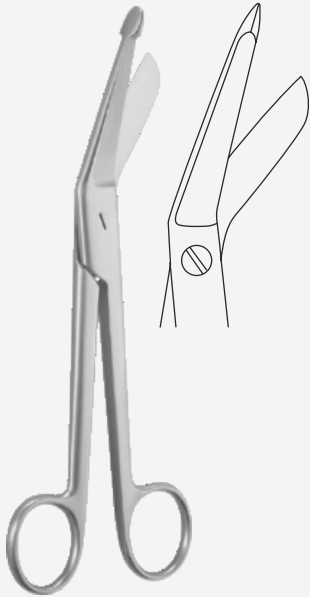

Lister

04-771-09	9 cm - 3 1/2"
04-771-11	11 cm - 4 1/4"
04-771-14	14 cm - 5 1/2"
04-771-18	18 cm - 7"
04-771-20	20 cm - 8"
04-771-25	25 cm - 10"
04-771-30	30 cm - 11 3/4"



Lister

04-772-14T	14 cm - 5 1/2"
04-772-18T	18 cm - 7"
04-772-20T	20 cm - 8"
04-773-14S	14 cm - 5 1/2"
04-773-18S	18 cm - 7"
04-773-20S	20 cm - 8"

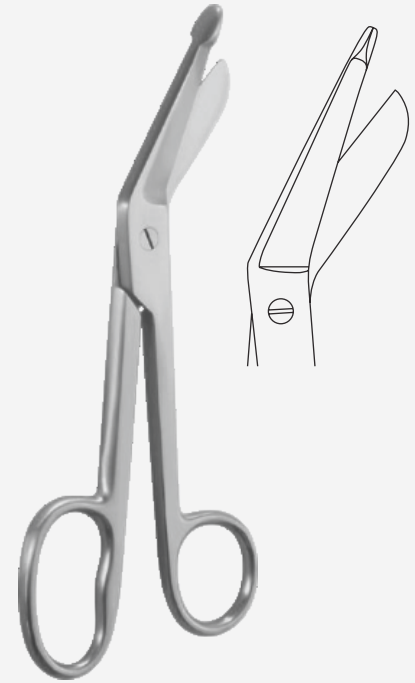

Lister - Modified

04-774-18	18 cm - 7"
04-774-20	20 cm - 8"
04-775-20S	20 cm - 8"



Knowles

04-777-14	14 cm / 5 1/2"
-----------	----------------

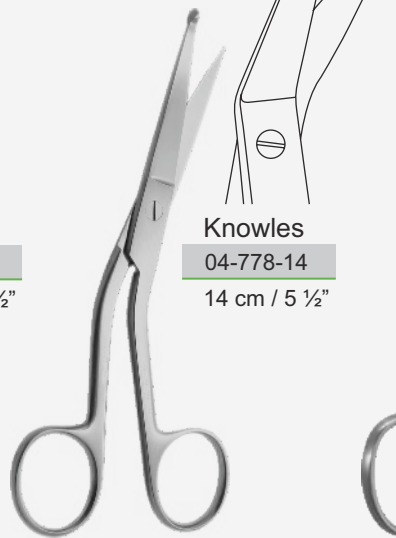

Knowles

04-778-14	14 cm / 5 1/2"
-----------	----------------



Sharp - Modified

04-779-16	16 cm / 6 1/4"
-----------	----------------



Smith (Mod. USA)

04-780-16	16 cm / 6 1/4"
04-780-18	18 cm / 7"
04-780-20	20 cm / 8"
04-780-23	23 cm / 9"





**Lange**  
04-776-18  
18 cm / 7"

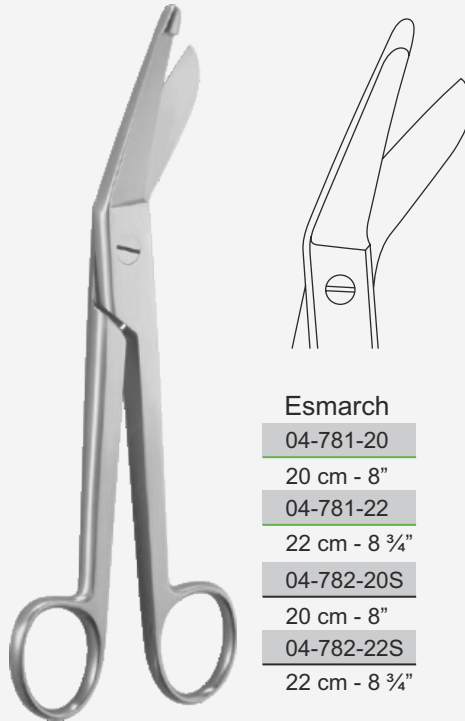

**Esmarch**  
04-781-20  
20 cm - 8"  
04-781-22  
22 cm - 8 3/4"  
04-782-20S  
20 cm - 8"  
04-782-22S  
22 cm - 8 3/4"

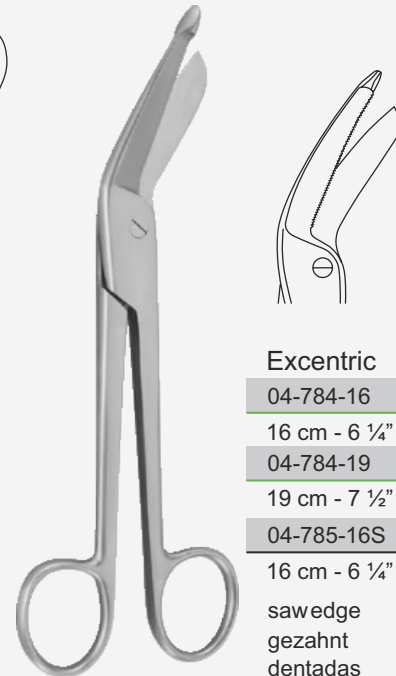

**Excentric**  
04-784-16  
16 cm - 6 1/4"  
04-784-19  
19 cm - 7 1/2"  
04-785-16S  
16 cm - 6 1/4"  
sawedge  
gezahnt  
dentadas  
dentelés

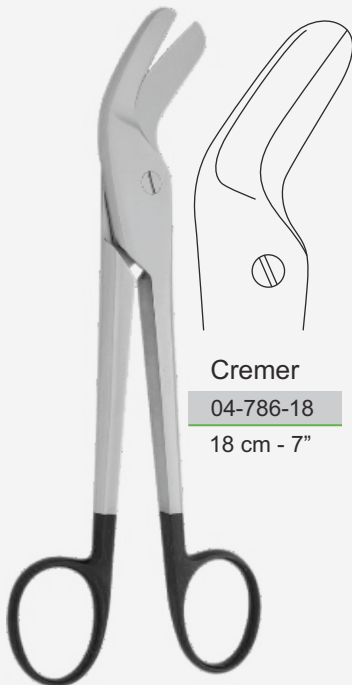

**Cremer**  
04-786-18  
18 cm - 7"

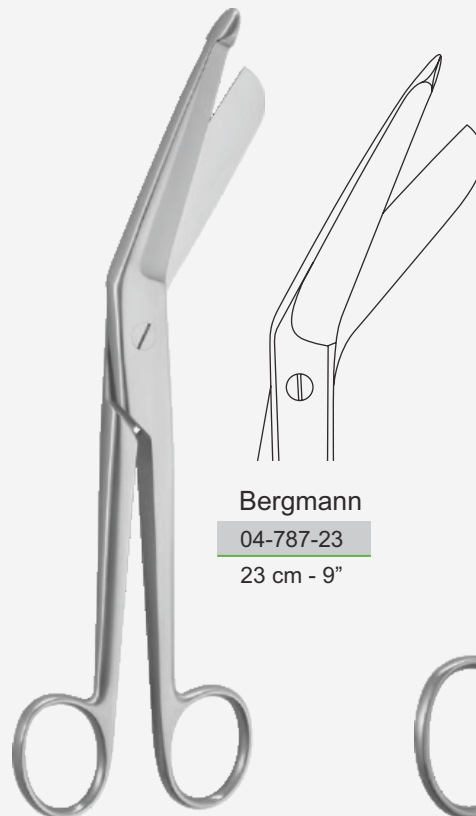

**Bergmann**  
04-787-23  
23 cm - 9"

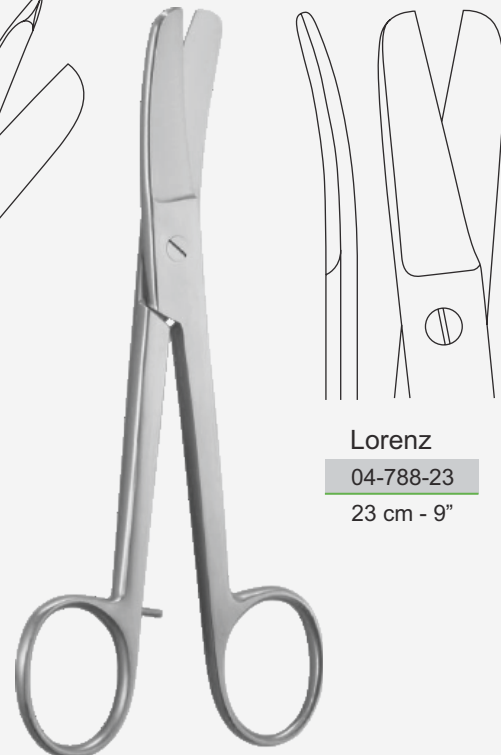

**Lorenz**  
04-788-23  
23 cm - 9"

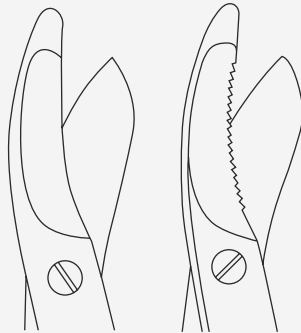

**Brun's**

04-789-24

24 cm - 9 1/2"

04-790-24

24 cm - 9 1/2"

saw edge  
 gezahnt  
 dentadas  
 dentelés



**Brun's**

04-791-24

24 cm - 9 1/2"

04-792-24S

24 cm - 9 1/2"

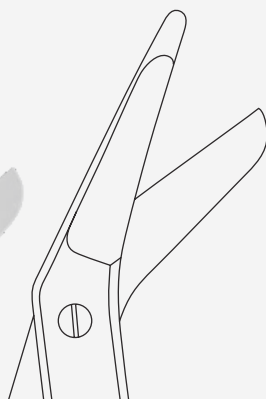

**Western**

04-793-20

20 cm - 8"

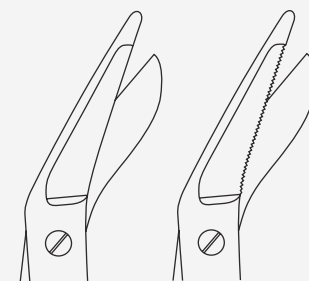

**Seutin**

04-794-23

23 cm - 9"

04-795-23

23 cm - 9"

saw edge  
 gezahnt  
 dentadas  
 dentelés



Plaster  
04-796-23  
23 cm - 9"



Wendy  
04-797-22  
22 cm - 8 3/4"



Collin  
04-798-19  
19 cm - 7 1/2"



Gluck  
04-799-19  
19 cm - 7 1/2"  
04-800-22  
22 cm - 8 3/4"



Stille  
04-801-21  
21 cm - 8 1/4"

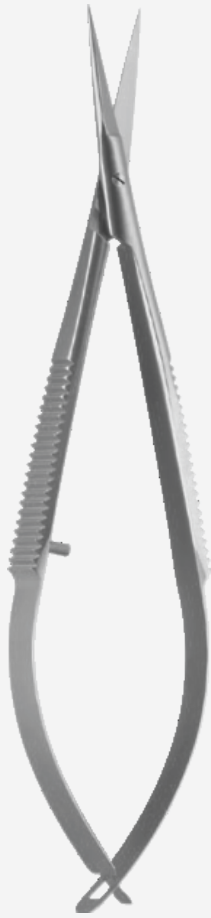

**Noyes**

04-802-12

sharp – sharp  
 spitz – spitz  
 roma – roma  
 pointue – pointue



04-803-12

sharp – blunt  
 spitz – stumpf  
 roma – aguda  
 pointue – mousse



04-804-12

blunt – blunt  
 stumpf – stumpf  
 aguda – aguda  
 mousse – mousse

12 cm - 4 3/4"

straight  
 gerade  
 recta  
 droits



**Noyes**

04-805-12

sharp – sharp  
 spitz – spitz  
 roma – roma  
 pointue – pointue



04-806-12

sharp – blunt  
 spitz – stumpf  
 roma – aguda  
 pointue – mousse



04-807-12

blunt – blunt  
 stumpf – stumpf  
 aguda – aguda  
 mousse – mousse

12 cm / 4 3/4"

angulated  
 abgewinkelt  
 angulado  
 coudé

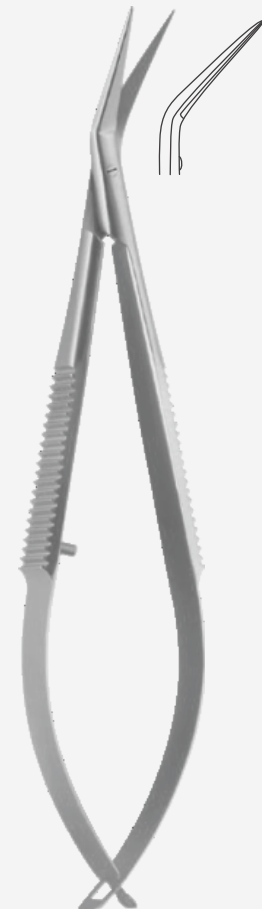



Vannas

04-808-12

12 cm - 4 3/4"

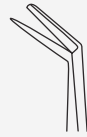

Wecker

04-809-12

sharp – blunt  
spitz – stumpf  
roma – aguda  
pointue – mousse



04-810-12

blunt – blunt  
stumpf – stumpf  
aguda – aguda  
mousse – mousse

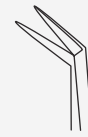

04-811-12

sharp – sharp  
spitz – spitz  
roma – roma  
pointue – pointue



Barraquer

04-812-05

5.5 cm - 2 1/4"  
x = 0.7 cm

04-813-05

5.5 cm - 2 1/4"  
x = 1 cm

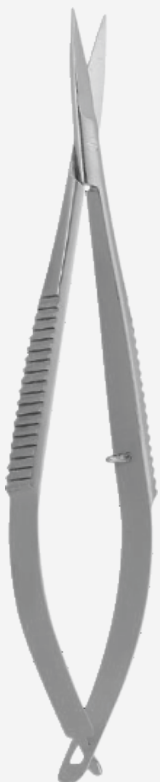

Westcott

04-814-11

11.5 cm - 4 1/2"



04-815-11

11.5 cm - 4 1/2"

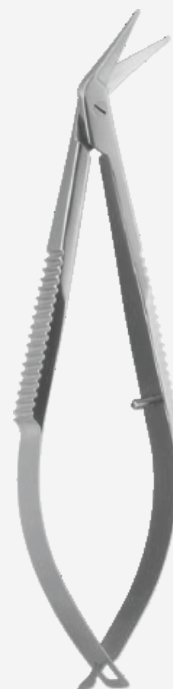

Castroviejo

04-816-09

9 cm - 3 1/2"

Micro scissors  
 Mikroscheren  
 Micro-tijeras  
 Micro-ciseaux  
 forbici micro



**Vannas Micro**

04-817-08

8 cm / 3 1/4"

04-818-08

8 cm / 3 1/4"

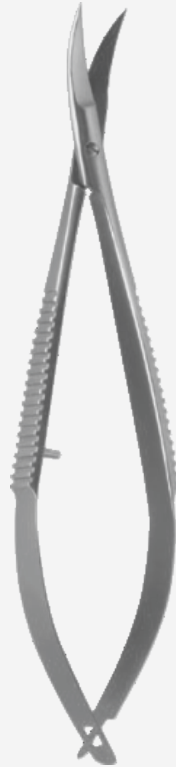
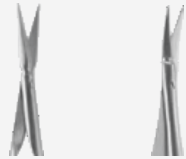

**Castroviejo**

04-819-10

10 cm - 4"

sharp – sharp  
 spitz – spitz  
 aguda – aguda  
 pointue – pointue



04-820-10

10 cm - 4"

blunt – blunt  
 stumpf – stumpf  
 roma – roma  
 mousse – mousse

Tenotomy scissors  
 Sehnenscheren  
 Ciseaux à ténnotomie  
 Tijeras para tenotomia  
 Ombre tendini

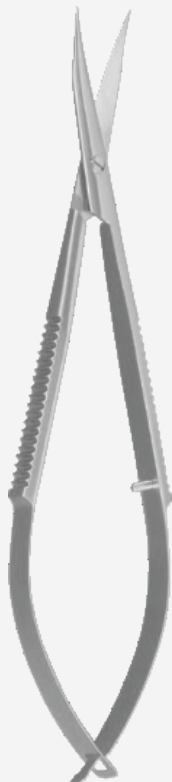

**Westcott**

04-821-11

sharp – sharp  
 spitz – spitz  
 aguda – aguda  
 pointue – pointue



04-825-11 11 cm - 4 1/4"

blunt – blunt  
 stumpf – stumpf  
 roma – roma  
 mousse – mousse



Dissecting - Tissue Forceps  
Präparieren - Gewebezange  
Disección - Pinzas para tejidos  
Dissection - Pince à tissus  
Dissezione - Forcipe per tessuti



Standard

05-901-08
05-901-10
05-901-11
05-901-13
05-901-14
05-901-15
05-901-16
05-901-18
05-901-20
05-901-25
05-901-30
05-901-35



05-902-08

05-902-10
05-902-11
05-902-13
05-902-14
05-902-15
05-902-16
05-902-18
05-902-20
05-902-25
05-902-30
05-902-35

narrow  
 schmal  
 estrecha  
 étroite  
 strette



05-903-08

8 cm - 3 ¼"	
05-903-10	10.5 cm - 4 ¼"
05-903-11	11.5 cm - 4 ½"
05-903-13	13 cm - 5"
05-903-14	14.5 cm - 5 ¾"
05-903-15	15 cm - 6"
05-903-16	16 cm - 6 ¼"
05-903-18	18 cm - 7"
05-903-20	20 cm - 8"
05-903-25	25 cm - 10"
05-903-30	30 cm - 12"
05-903-35	35 cm - 14"



05-901-24R 24 cm - 9½"





**Mehmet**

05-904-13	13 cm - 5"
05-904-14	14.5 cm - 5 ¾"
05-904-16	16 cm - 6 ¼"

cross serated  
kreuzgerieft  
estriada  
striée  
zigrinato a croce

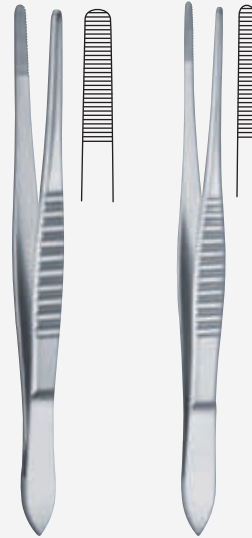

**Mod. USA**

05-905-12	05-906-12	12 cm - 4 ¾"
05-905-13	05-906-13	13 cm - 5"
05-905-14	05-906-14	14.5 cm - 5 ¾"
05-905-15	05-906-15	15.5 cm - 6"
05-905-18	05-906-18	18 cm - 7"
05-905-21	05-906-21	21 cm - 8 ¼"
05-905-25	05-906-25	25 cm - 9 ¾"
05-905-31	05-906-31	31 cm - 12 ¼"

narrow  
schmal  
estrecha  
étroite  
strette

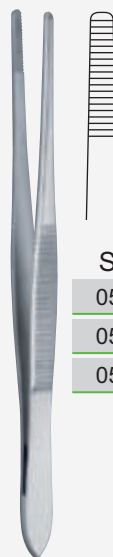

**Stille**

05-907-15	15 cm - 6"
05-907-18	18 cm - 7"
05-907-20	20 cm - 8"



**Semken**

05-908-12	12.5 cm - 5"
05-908-15	15 cm - 6"



Taylor  
 Fig. 1

05-909-17  
 17.5 cm - 7"



Fig. 2

05-910-17  
 17.5 cm - 7"



Fig. 3

05-911-17  
 17.5 cm - 7"



Gerald  
 Fig. 1

05-912-18  
 18 cm - 7"



Fig. 2

05-913-18  
 18 cm - 7"



Fig. 3

05-914-18  
 18 cm - 7"



Adson

05-915-12 12 cm - 4 3/4"

05-915-15 15 cm - 6"



Micro-Adson

05-916-12 12 cm - 4 3/4"

05-916-15 15 cm - 6"



Adson

05-917-12

12 cm - 4 3/4"  
 cross serrated



Hudson  
 (Ewald)

05-918-12

12 cm - 4 3/4"



Waugh

05-920-15	15 cm - 6"
05-920-18	18 cm - 7"
05-920-20	20 cm - 8"
05-920-25	25 cm - 9 3/4"



Potts-Smith

05-921-18
05-921-21
05-921-25

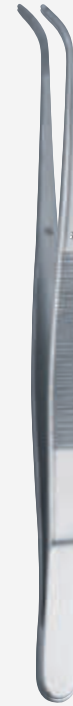

Brophy

05-922-18	18 cm - 7"
05-922-21	21 cm - 8 1/4"
05-922-25	25 cm - 9 3/4"



Mc Indoe

04-147-15	15 cm - 6"
-----------	------------



Gillies

04-148-15	15 cm - 6"
-----------	------------

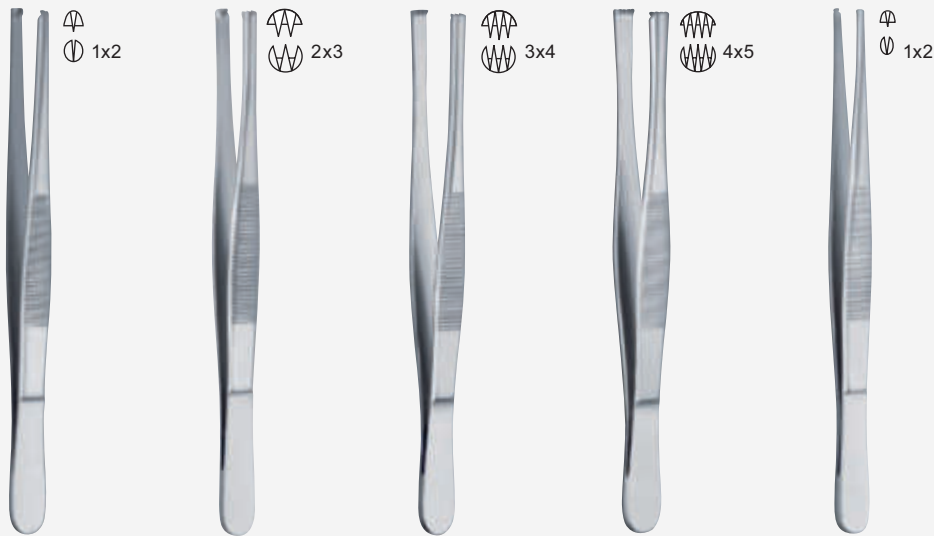

Standard

05-923-10	05-924-10	05-925-10	05-926-10	05-927-10	10.5 cm - 4 1/4"
05-923-11	05-924-11	05-925-11	05-926-11	05-927-11	11.5 cm - 4 1/2"
05-923-13	05-924-13	05-925-13	05-926-13	05-927-13	13 cm - 5"
05-923-14	05-924-14	05-925-14	05-926-14	05-927-14	14.5 cm - 5 3/4"
05-923-15	05-924-15	05-925-15	05-926-15	05-924-15	15 cm - 6"
05-923-16	05-924-16	05-925-16	05-926-16	05-927-16	16 cm - 6 1/4"
05-923-18	05-924-18	05-925-18	05-926-18	05-927-18	18 cm - 7"
05-923-20	05-924-20	05-925-20	05-926-20	05-927-20	20 cm - 8"
05-923-25	05-924-25	05-925-25	05-926-25	05-927-25	25 cm - 10"
05-923-30	05-924-30	05-925-30	05-926-30	05-927-30	30 cm - 12"
05-923-35	05-924-35	05-925-35	05-926-35	05-927-35	35 cm - 14"

narrow  
 schmal  
 estrecha  
 étroite  
 strette



Stille

05-928-15

05-929-15

15 cm - 6"



Mod. USA

05-930-12 12 cm - 4 3/4"

05-930-13 13 cm - 5"

05-930-14 14.5 cm - 5 3/4"

05-930-15 15.5 cm - 6"

05-930-18 18 cm - 7"

05-930-21 21 cm - 8 1/4"

05-930-25 25 cm - 9 3/4"

05-930-31 31 cm - 12 1/4"



Stone

05-931-15

15 cm - 6"



Lerche

05-932-15

15 cm - 6"

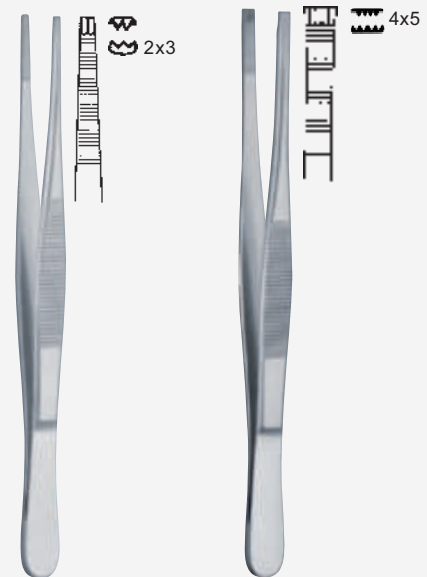

Adlerkreutz

05-933-15

05-934-15

15 cm - 6"

05-933-20

05-934-20

20 cm - 8"

05-933-25

05-934-25

25 cm - 9 3/4"



Brophy

05-935-20

05-936-20

20 cm - 8"



Potts-Smith

05-937-18

05-938-18

18 cm - 7"

05-937-21

05-938-21

21 cm - 8 1/2"

05-937-25

05-938-25

25 cm - 9 3/4"



Hudson  
(Ewald)

05-939-12

12 cm - 4 3/4"



Adson

05-940-01

05-940-02



Adson

05-940-12

12 cm - 4 3/4"

05-940-15

15 cm - 6"

Cross serrated



Adson-  
Graefe

05-941-12

12 cm - 4 3/4"



Adson-Micro

05-942-12

05-942-15

Fig. 1



05-943-12

05-943-15

Fig. 2

12 cm - 4 3/4"

15 cm - 6"

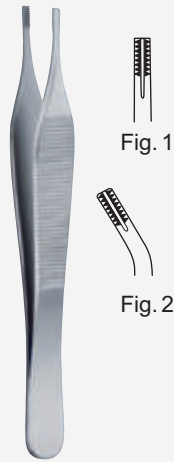

Adson-Brown

05-944-12

05-945-12

Str.

12 cm - 4 3/4"

12 cm - 4 3/4"

Cvd.

12 cm - 4 3/4"



Adson

05-150-15

15 cm - 6"



Adson

05-151-12

12 cm - 4 3/4"

Standard

Cross Serrated



05-152-12

12 cm - 4 3/4"

Micro

Cross Serrated



05-153-12

12 cm - 4 3/4"

Standard



05-154-12

12 cm - 4 3/4"

Micro



Mc Indoe

04-248-15

15 cm / 6"

With pin



Gillies

05-946-15

15 cm - 6"



Semken

05-947-12

12.5 cm - 5"

05-947-15

15 cm - 6"



Duval

05-948-14

14.5 cm - 5 3/4"

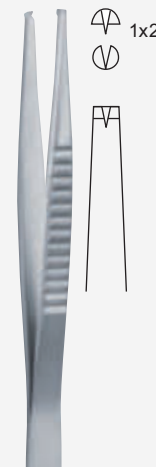

Treves

05-949-12

12.5 cm - 5"

05-949-15

15 cm - 6"



Toe

04-123-13

13 cm - 5"

04-123-15

15 cm - 6"

04-123-18

18 cm - 7"

04-123-20

20 cm - 8"



Bonney

05-950-17	1 x 2 teeth
05-950-17B	Non-toothed
17.5 cm - 7"	
Fig. 1	



05-951-17	2 x 3
17.5 cm - 7"	
Fig. 2	



Ferris-Smith

05-952-18	1 x 2 teeth
05-952-18B	Non-toothed
18 cm - 7"	
Fig. 1	



05-953-18	2 x 3
18 cm - 7"	
Fig. 2	



Lane

05-954-14	05-955-14	14.5 cm - 5 3/4"
05-954-20	05-955-20	20 cm - 8"
Fig. 1		



Fig. 2



Brown

05-956-15	15 cm - 6"
05-956-20	20 cm - 8"
05-956-25	25 cm - 9 3/4"



Denis  
Browne

05-957-19	19 cm - 7 1/2"
-----------	----------------



Waugh

05-958-15	15 cm - 6"
05-958-20	20 cm - 8"
05-958-25	25 cm - 9 3/4"





Stille-Barraya

05-959-18 18 cm - 7"

05-959-20 20 cm - 8"

05-959-25 25 cm - 9 3/4"



Taylor

05-960-17



05-961-17



05-962-17 17.5 cm - 7"



Gerald

05-963-17

17 cm - 6 3/4"



05-964-17

17 cm - 6 3/4"



05-965-18

18 cm - 7"



Cushing

05-966-17

17 cm - 6 3/4"



05-967-17

17 cm - 6 3/4"

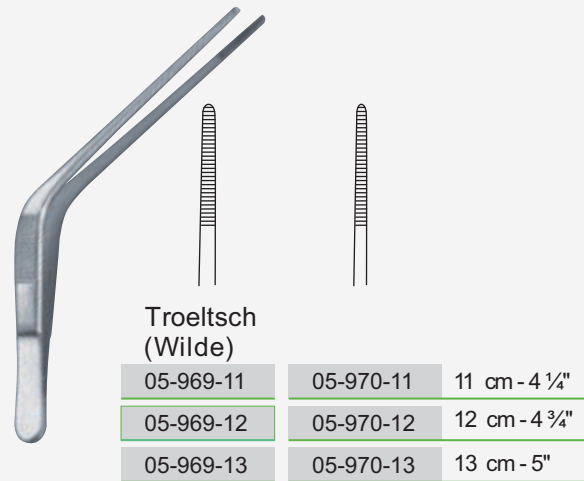
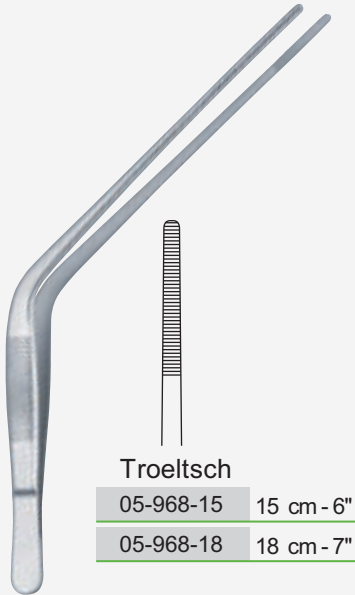

cross action  
 gekreuzt  
 cruzado  
 croisé  
 crociato





**Iris**

05-976-10	05-977-10	05-978-10	05-979-10	05-980-10	05-981-10	10.5 cm - 4 1/4"
05-976-11	05-977-11	05-978-11	05-979-11	05-980-11	05-981-11	11.5 cm - 4 1/4"
05-976-12	05-977-12	05-978-12	05-979-12	05-980-12	05-981-12	12.5 cm - 4 1/4"
05-976-14	05-977-14	05-978-14	05-979-14	05-980-14	05-981-14	14.5 cm - 4 1/4"
05-976-15	05-977-15	05-978-15	05-979-15	05-980-15	05-981-15	15 cm - 4 1/4"
05-976-16	05-977-16	05-978-16	05-979-16	05-980-16	05-981-16	16 cm - 4 1/4"

Straight

Curved

Heavy curved

Straight  
1x2

Curved  
1x2

Heavy curved  
1x2

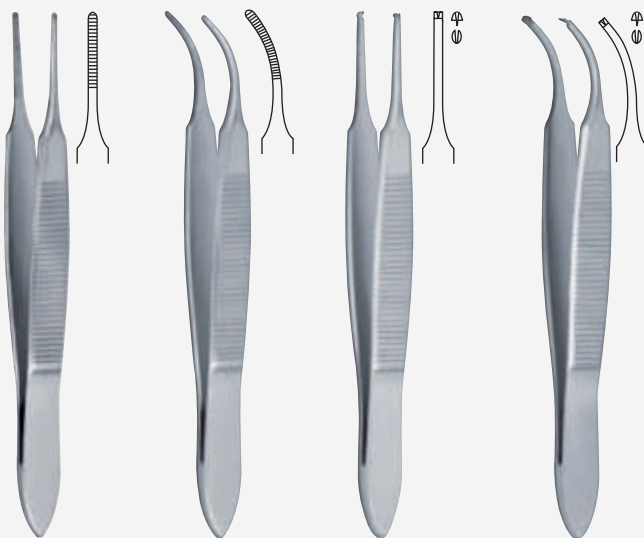

**Graefe**

05-982-07	05-983-07	05-984-07	05-985-07	0.7 mm
05-982-01	05-983-01	05-984-01	05-985-01	1.0 mm
7 cm - 2 3/4"	7 cm - 2 3/4"	7 cm - 2 3/4"	7 cm - 2 3/4"	
Straight	Curved	Straight 1x2	Curved 1x2	



**Finoway**

05-986-09	05-987-09	9 cm - 3 ½"
05-986-10	05-987-10	10.5 cm - 4 ¼"
05-986-11	05-987-11	11.5 cm - 4 ½"
05-986-12	05-987-12	12.5 cm - 5"

smooth  
 glatt  
 lisa  
 lisse  
 liscio



05-988-09	05-989-09	9 cm - 3 ½"
05-988-10	05-989-10	10.5 cm - 4 ¼"
05-988-11	05-989-11	11.5 cm - 4 ½"
05-988-12	05-989-12	12.5 cm - 5"

serrated  
 gerieft  
 estriada  
 striée  
 zigrinato



**Durante**

05-990-14	14.5 cm - 5 3/4"
05-990-16	16 cm - 6 1/4"
05-990-20	20 cm - 8"



**Russian Model**

05-991-15	15 cm - 6"
05-991-20	20 cm - 8"
05-991-25	25 cm - 9 3/4"
05-991-30	30 cm - 11 3/4"

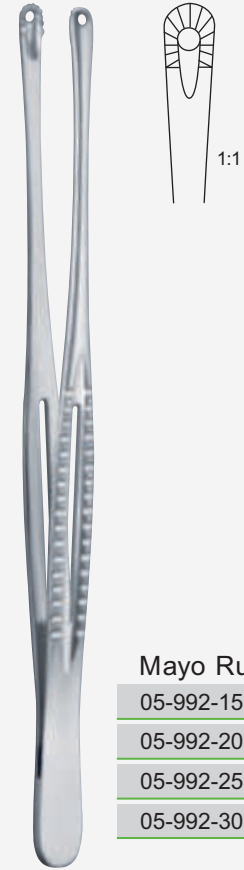

**Mayo Russian**

05-992-15	15 cm - 6"
05-992-20	20 cm - 8"
05-992-25	25 cm - 9 3/4"
05-992-30	30 cm - 11 3/4"



**Nelson**

05-993-23	23 cm - 9"
-----------	------------



**Singley-Tuttle**

05-994-18	18 cm - 7"
05-995-23	23 cm - 9"
05-996-35	35 cm - 14"



**Collin Duval**

05-997-20	20 cm - 8"	x = 14 mm
-----------	------------	-----------



05-998-20	x = 18 mm
-----------	-----------



05-999-20	x = 27 mm
-----------	-----------





De Bakey

05-100-12	05-101-12	05-102-12	05-103-12	12 cm - 4 3/4"
05-100-14	05-101-14	05-102-14	05-103-14	14.5 cm - 5 3/4"
05-100-16	05-101-16	05-102-16	05-103-16	16 cm - 6 1/2"
05-100-20	05-101-20	05-102-20	05-103-20	20 cm - 8"
05-100-24	05-101-24	05-102-24	05-103-24	24 cm - 9 1/2"
05-100-30	05-101-30	05-102-30	05-103-30	30 cm - 12"
05-100-35	05-101-35	05-102-35	05-103-35	35 cm - 14"

x = 1.5 mm

x = 2.0 mm

x = 2.7 mm

x = 3.5 mm

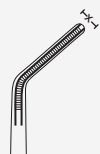

x = 1.5 mm

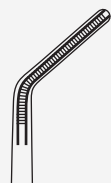

x = 2.0 mm

05-104-14	05-105-14	14.5 cm - 5 3/4"
05-104-16	05-105-16	16 cm - 6 1/2"
05-104-20	05-105-20	20 cm - 8"
05-104-24	05-105-24	24 cm - 9 1/2"
05-104-30	05-105-30	30 cm - 12"

x = 1.5 mm

x = 2.0 mm



De Bakey

05-106-16	05-107-16	05-108-16	05-109-16	05-110-16	16 cm - 6 1/2"
05-106-20	05-107-20	05-108-20	05-109-20	05-110-20	20 cm - 8"
05-106-24	05-107-24	05-108-24	05-109-24	05-110-24	24 cm - 9 1/2"

x = 1.2 mm  
 Titanium

x = 1.5 mm

x = 1.8 mm

x = 2.0 mm

x = 2.8 mm



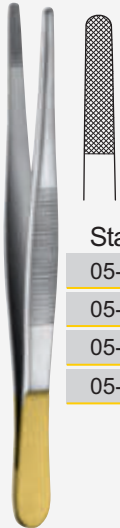

**Standard**

05-111-14T	14.5 cm - 5 ¾"
05-111-20T	20 cm - 8"
05-111-25T	25 cm - 9 ¾"
05-111-30T	30 cm - 12"



**Mc Indoe**

05-112-15T	15 cm 6"
------------	----------



**Potts-Smith**

05-113-18T	18 cm - 7"
05-113-21T	21 cm - 8 ¼"
05-113-25T	25 cm - 9 ¾"



**Adson**

05-114-12T	12 cm - 4 ¾"
05-114-15T	15 cm - 6"



**Wangensteen**

05-115-15T	15 cm - 6"
05-115-23T	23 cm - 9"



**Cushing**

05-116-17T	17.5 cm - 7"
------------	--------------



**Taylor**

05-117-18T	18 cm - 7"
------------	------------



Adson

05-118-12T 12 cm - 4 ¾"

05-118-15T 15 cm - 6"



Adson-Micro

05-119-12T

05-119-15T



Adson-Brown

05-120-12T

05-120-15T



Gillies

05-121-15T

15 cm - 6"



Oehler

05-122-14T

14 cm - 5 ½"



05-123-16T

16 cm - 4 ¼"



05-124-18T

18 cm - 7"



05-125-20T

20 cm - 8"



05-126-25T

25 cm - 9 ¾"



05-127-30T

30 cm - 12"



De Bakey

05-128-15T

05-128-19T

05-128-24T

x = 1.5 mm



05-129-15T 15 cm - 6"

05-129-19T 19 cm - 7 ½"

05-129-24T 24 cm - 9 ½"

x = 2.0 mm



**Feilchenfeld**

05-130-07	7.5 cm - 3"
05-130-09	9 cm - 3½"
05-130-11	11.5 cm - 4 ½"



**Hunter**  
05-131-10



05-132-10 10.5 cm - 4 ¼"



**Walter- Carmalt**

05-133-10



05-134-10 10.5 cm - 4 ½"



**Magnifier**

05-135-08  
8 cm - 3 ¼"

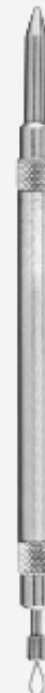

05-130-01  
Magnetic eye loop



**Morga**

05-136-08	8 cm - 3¼"
05-136-10	10 cm - 4"
05-136-12	12.5 cm - 5"



**Beer**  
 05-137-09  
 9 cm - 3 1/2"



**Douglas**  
 05-138-09      05-139-09      9 cm - 3 1/2"



**Littauer**  
 05-140-08      05-141-09  
 8.5 cm - 3 1/4"      9 cm - 3 1/2"



**Grade**  
 05-142-09  
 9.5 cm - 3 3/4"



**Barraquer**  
 05-143-10  
 10.5 cm - 4 1/4"

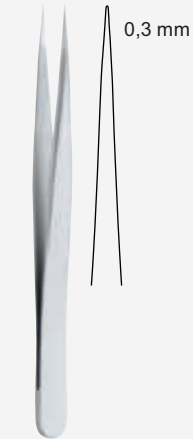

Jeweler  
Fig. 1  
05-175-12  
12 cm - 4 3/4"

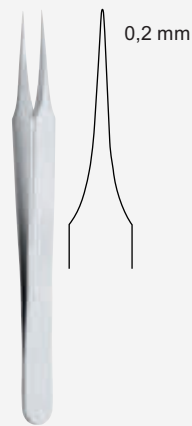

Jeweler  
Fig. 2  
05-176-11  
11 cm - 4 1/4"

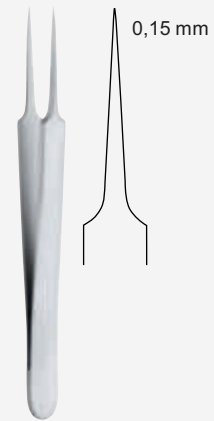

Jeweler  
Fig. 3  
05-177-11  
11 cm - 4 1/4"

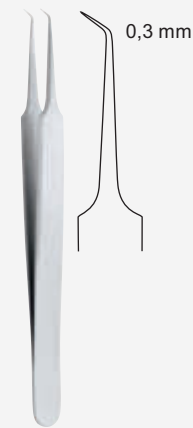

Jeweler  
Fig. 4  
05-178-11  
11 cm - 4 1/4"

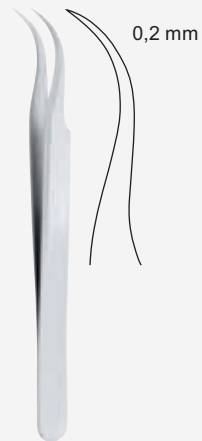

Jeweler  
Fig. 5  
05-179-11  
11.5 cm - 4 1/2"

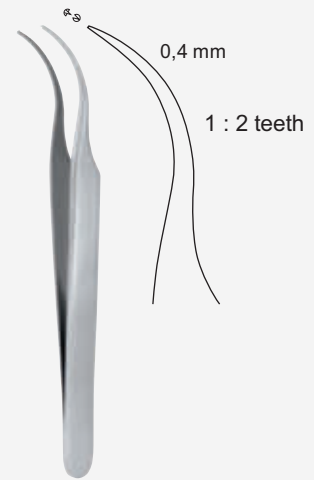

Jeweler  
Fig. 6  
05-180-11  
11.5 cm - 4 1/2"

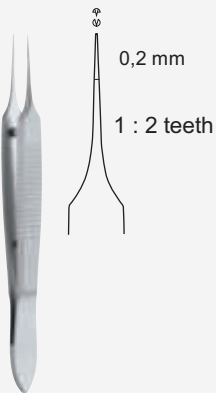

Steven  
05-184-09  
9.5 cm - 3 3/4"

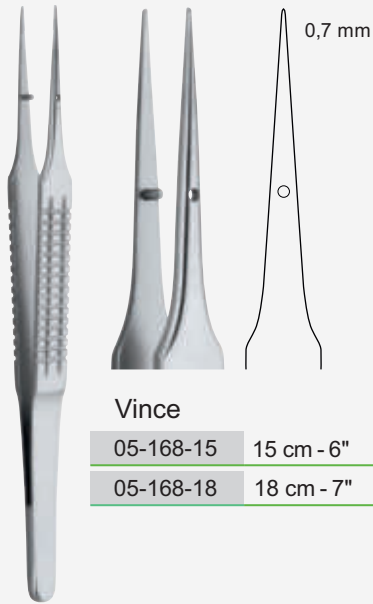

**Vince**  
 05-168-15 15 cm - 6"  
 05-168-18 18 cm - 7"

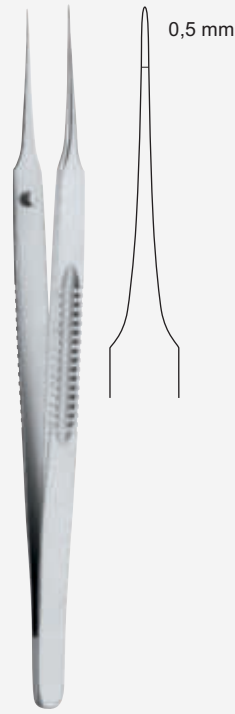

**Harry**  
 05-169-18  
 18 cm - 7"

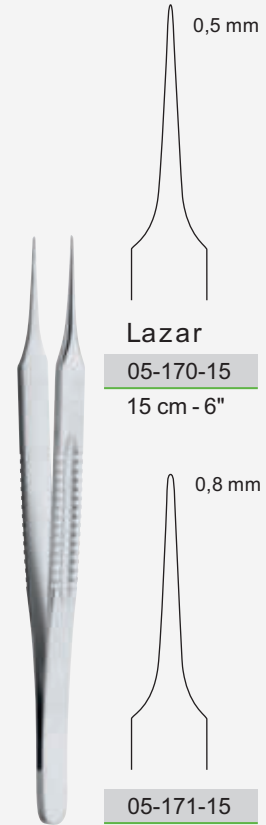

**Lazar**  
 05-170-15  
 15 cm - 6"

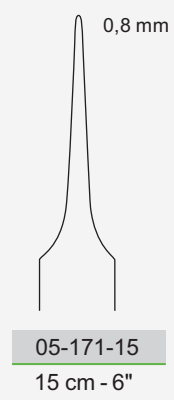

05-171-15  
 15 cm - 6"



**Austin**  
 05-172-14  
 14 cm - 5 1/2"

05-172-18  
 18 cm - 7"

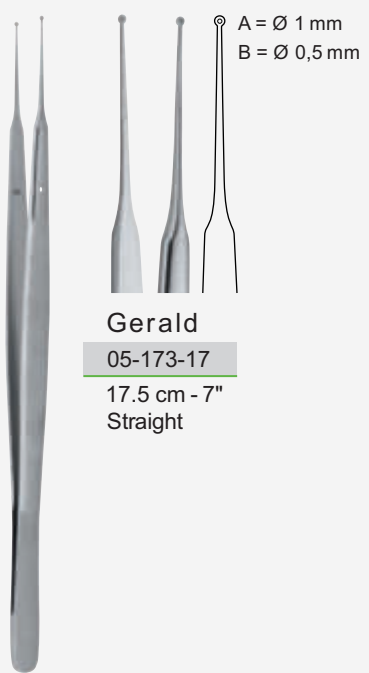

**Gerald**  
 05-173-17  
 17.5 cm - 7"  
 Straight

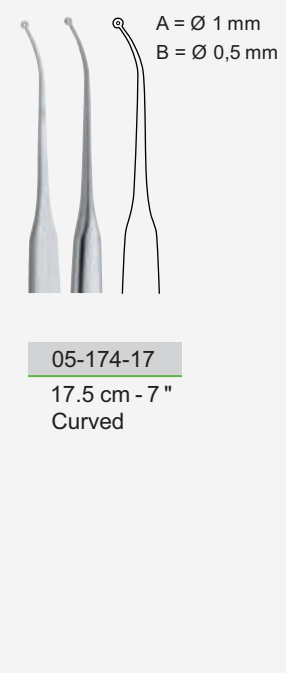

05-174-17  
 17.5 cm - 7"  
 Curved

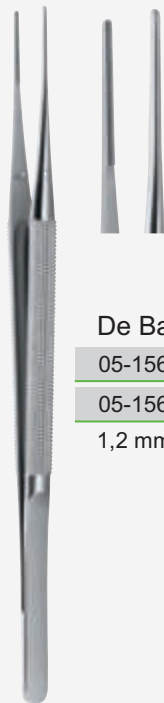

De Bakey

05-156-18	05-157-17	18 cm - 7"
05-156-21	05-157-21	21 cm - 8 ¼"
1,2 mm	2 mm	

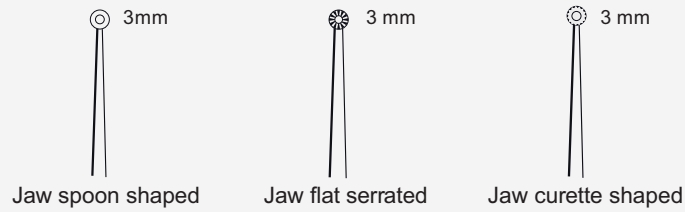

**Tumor Grasping**

05-190-22

22 cm - 8 3/4"

05-191-22

22 cm - 8 3/4"

05-192-22

22 cm - 8 3/4"

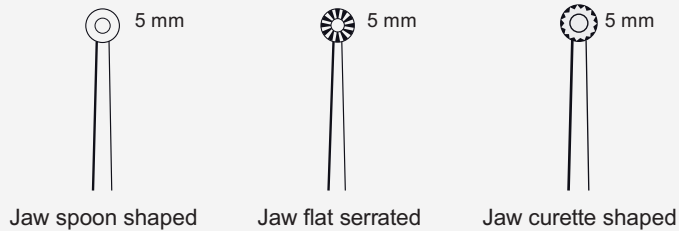

05-193-22

22 cm - 8 3/4"

05-194-22

22 cm - 8 3/4"

05-195-22

22 cm - 8 3/4"



⊙ Ø 3 mm

⊙ Ø 5 mm

⊙ Ø 7 mm

**Tumor Grasping**

05-271-22

05-271-24

05-272-22

05-272-24

05-273-22

05-273-24

22 cm - 8 3/4"

24 cm - 9 1/2"

⊙ Ø 3 mm

⊙ Ø 3

05-274-22

05-275-22

22 cm - 8 3/4"

⊙ Ø 5 mm

⊙ Ø 5 mm

05-276-22

05-277-22

22 cm - 8 3/4"



Artery - Haemostatic Forceps  
Arterie - Blutstillende Pinzette  
Arteria - Pinzas hemostáticas  
Artère - Pince hémostatique  
Arteria - Forcipe emostatico

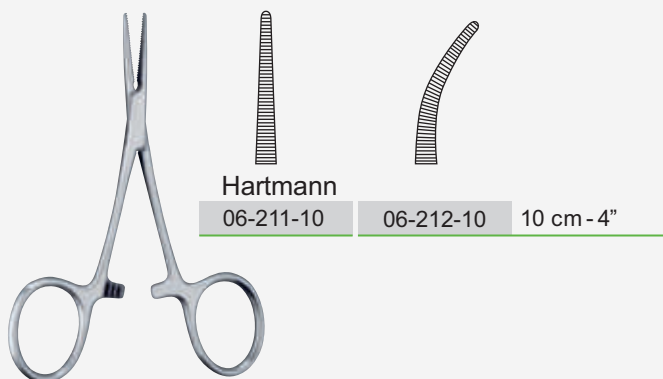

**Hartmann**  
 06-211-10 06-212-10 10 cm - 4"

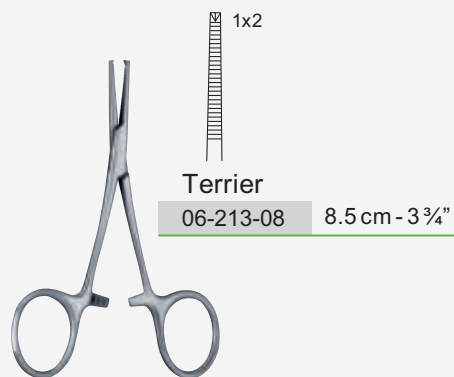

**Terrier**  
 06-213-08 8.5 cm - 3 3/4"



**Halsted-Mosquito**

06-214-12	06-215-12	06-216-12	06-217-12	12.5cm - 5"	06-215-01	12.5cm - 5" Str
06-214-14	06-215-14	06-216-14	06-217-14	14 cm - 5 1/2"	06-215-00	12.5cm - 5" Cvd
		1x2	1x2		Plain	
06-218-12	06-219-12	06-220-12	06-221-12	12.5 cm - 5"		
Titanium		1x2	1x2			
Titan						
Titanio						
Titane						
Titanio						



**Micro-Mosquito**

06-222-10	06-223-10	06-224-10	06-225-10	10 cm - 4"
06-222-12	06-223-12	06-224-12	06-225-12	12 cm - 4 3/4"
		1x2	1x2	



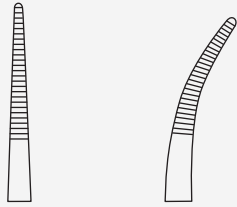
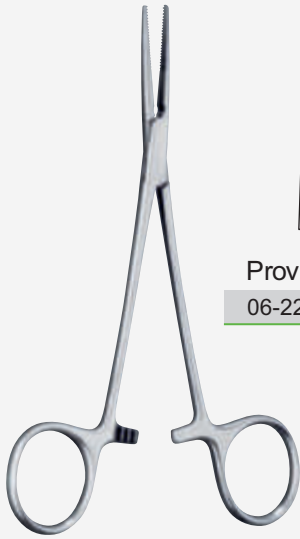

Providence-Hospital

06-226-14 06-227-14 14 cm - 5 1/2"

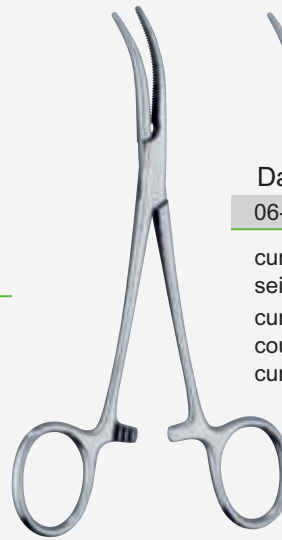

Dandy

06-228-14 06-229-14 14 cm - 5 3/4"

curved to the side 1x2  
seitlich gebogen  
curva al lado  
courbe sur le plat  
curvata lateralmente

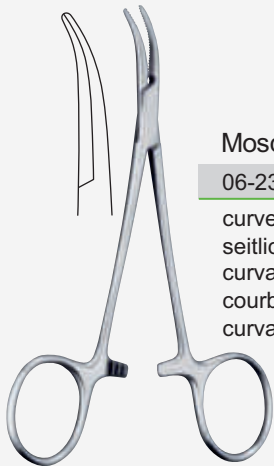

Mosquito-Dandy

06-230-12 12 cm - 4 3/4"

curved to the side  
seitlich gebogen  
curva al lado  
courbe sur le plat  
curvata lateralmente

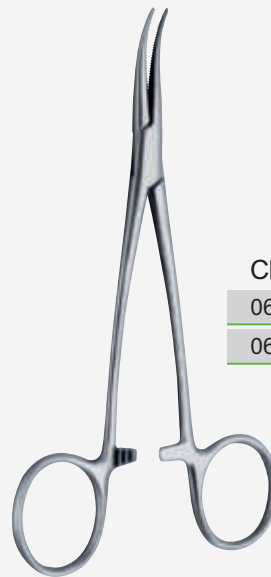

Christophe

06-231-13 13 cm - 4"

06-232-15 15 cm - 6"

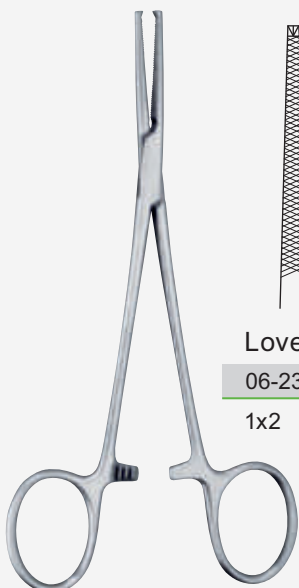

Lovelace

06-233-15 06-234-15 15.5 cm - 6"

1x2



Leriche

06-235-15 06-236-15 15 cm - 6"



Leriche

06-237-15  
 15 cm - 6"  
 1x2

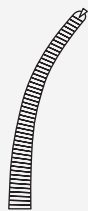

06-238-15  
 15 cm - 6"  
 1x2



Kelly

06-239-14

06-240-14

14 cm - 5 1/2"



Kelly-Rankin

06-241-16

06-242-16

16 cm - 6 1/4"



Crile

06-245-14

06-246-14

06-247-14

06-248-14

14 cm - 5 1/2"

1x2

1x2



Crile-Rankin

06-249-16

06-250-16

06-251-16

06-252-16

16 cm - 6 1/4"

1x2

1x2



Spencer-Wells (Str)

06-257-01

06-257-02

06-257-03

06-257-04

06-257-05

06-257-06

13 cm - 5 1/4"

14 cm - 5 1/2"

15.5 cm - 5 3/4"

18 cm - 6 3/4"

20 cm - 7 3/4"

23 cm - 9"

Spencer-Wells (Cvd)

06-257-08

06-257-09

06-257-10

06-257-11

06-257-12

06-257-13

13 cm - 5 1/4"

14 cm - 5 1/2"

15.5 cm - 5 3/4"

18 cm - 6 3/4"

20 cm - 7 3/4"

23 cm - 9"

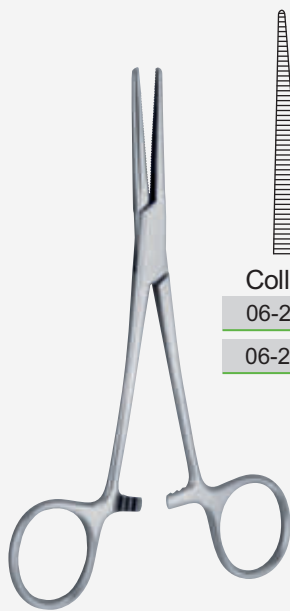

**Coller**

06-255-14	06-256-14	14 cm - 5 1/2"
-----------	-----------	----------------

06-255-16	06-256-16	16 cm - 6 1/4"
-----------	-----------	----------------

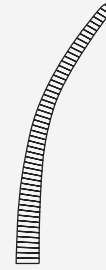

**Pean**

06-257-13	06-258-13	13 cm - 5"
-----------	-----------	------------

06-257-14	06-258-14	14 cm - 5 1/2"
-----------	-----------	----------------

06-257-16	06-258-16	16 cm - 6 1/4"
-----------	-----------	----------------

delicate pattern  
graziles Modell  
modelo delicado  
modèle délicat  
modello delicato

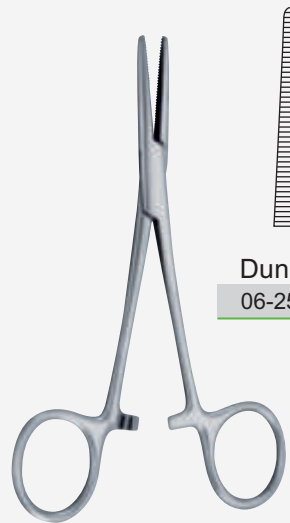

**Dunhill**

06-259-12	12.5 cm - 5"
-----------	--------------

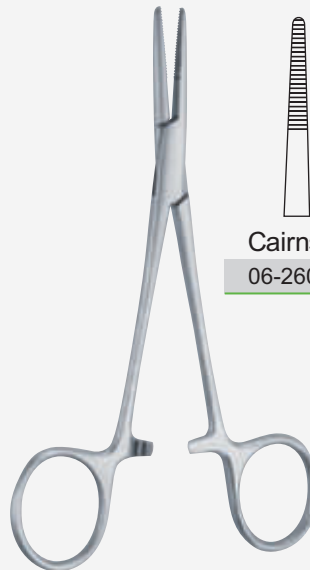

**Cairns**

06-260-15	
-----------	--

06-261-15	15 cm - 6"
-----------	------------



**Kocher**

06-262-13	06-263-13	13 cm - 5"
-----------	-----------	------------

06-262-14	06-263-14	14 cm - 5 1/2"
-----------	-----------	----------------

06-262-16	06-263-16	16 cm - 6 1/4"
-----------	-----------	----------------

1x2

1x2

delicate pattern  
graziles Modell  
modelo delicado  
modèle délicat  
modello delicato

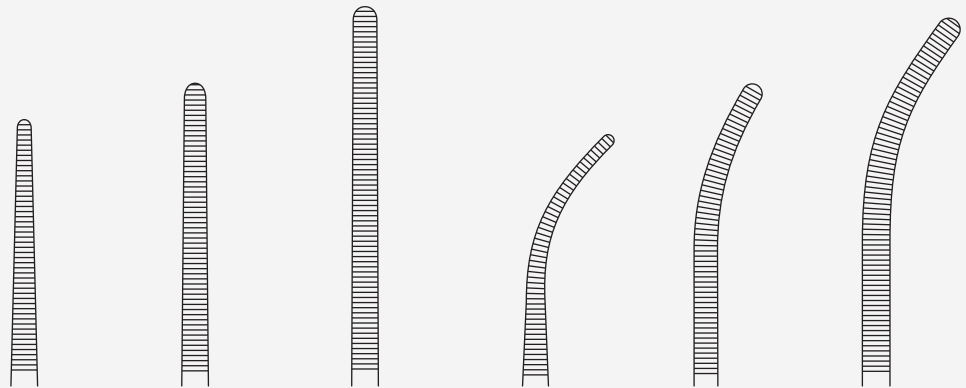

**Pean-Fino**

06-264-14	06-265-16	06-266-18	06-267-14	06-268-16	06-269-18
14.5 cm - 5 1/2"	16.5 cm - 6 1/2"	18.5 cm - 7 1/4"	14 cm - 5 1/2"	16 cm - 6 1/4"	18 cm - 7"

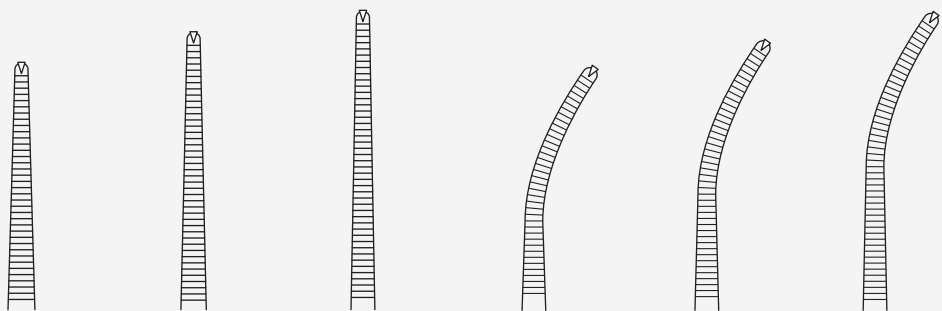

**Kocher-Fino**

06-270-14	06-271-16	06-272-18	06-273-14	06-274-16	06-275-18
14.5 cm - 5 3/4" 1x2	16.5 cm - 6 1/2" 1x2	18.5 cm - 7 1/4" 1x2	14 cm - 5 1/2" 1x2	16 cm - 6 1/4" 1x2	18 cm - 7" 1x2

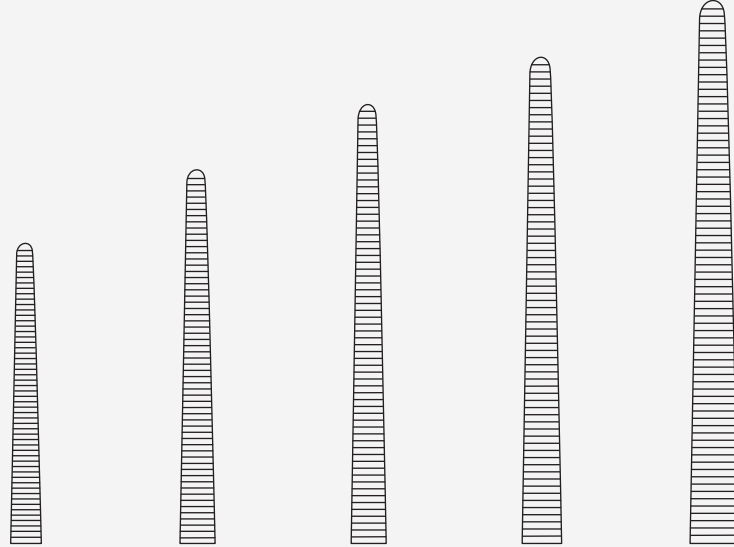

Rochester - Pean

06-276-14

14 cm - 5 1/2"

06-277-16

16 cm - 6 1/4"

06-278-18

18 cm - 7"

06-279-20

20 cm - 8"

06-280-22

22 cm - 8 3/4"

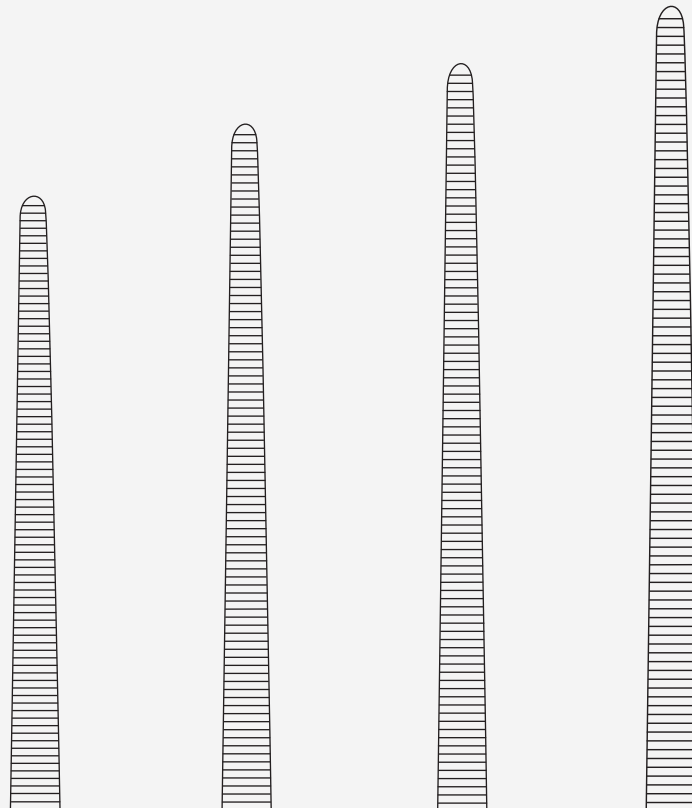

06-281-24

24 cm - 9 1/2"

06-282-26

26 cm - 10 1/4"

06-283-30

30 cm - 12"

06-284-35

35 cm - 14"

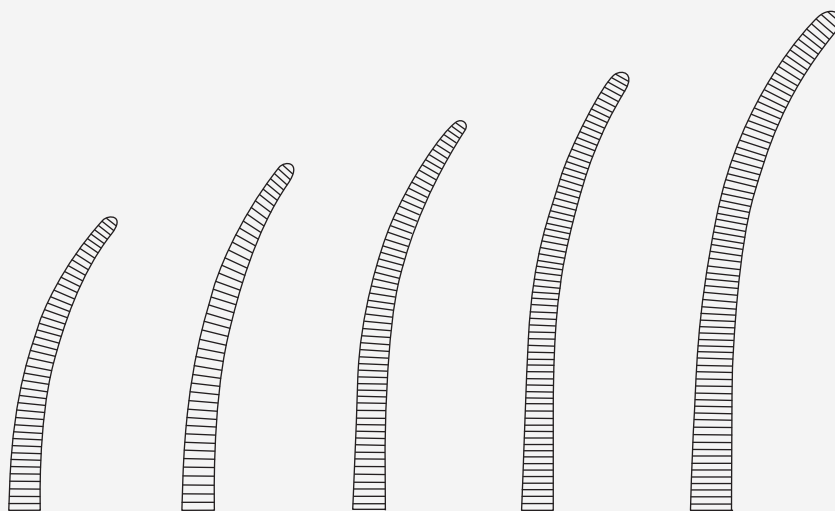

Rochester - Pean

06-285-14

14 cm - 5 1/2"

06-286-16

16 cm - 6 1/4"

06-287-18

18 cm 7"

06-288-20

20cm 8"

06-289-22

22 cm - 8 3/4"

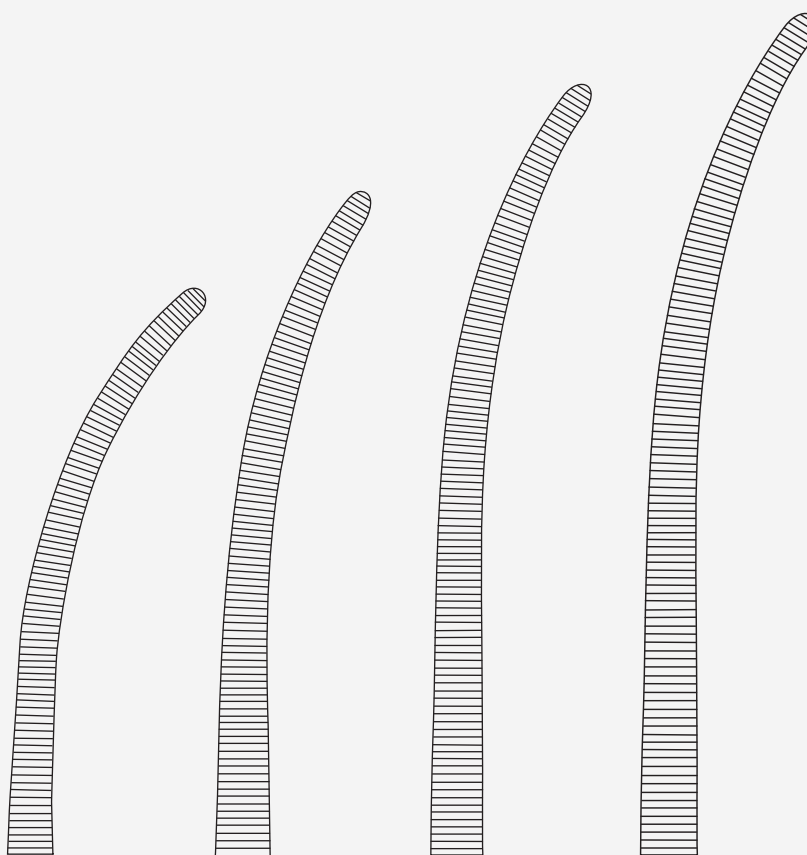

06-290-24

24 cm - 9 1/2"

06-291-26

26 cm - 10 1/4"

06-292-30

30 cm - 12"

06-293-35

35 cm - 14"



**Kocher**

06-294-14

14 cm - 5 1/2"  
1x2

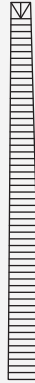

06-295-16

16 cm - 6 1/4"  
1x2



06-296-18

18 - cm 7"  
1x2



06-297-20

20 - cm 8"  
1x2



06-298-22

22 cm - 8 3/4"  
1x2



06-299-24

24 cm - 9 1/2"  
1x2



06-300-26

26 cm - 10 1/4"  
1x2



06-301-30

30 cm - 12"  
1x2



06-302-35

35 cm - 14"  
1x2

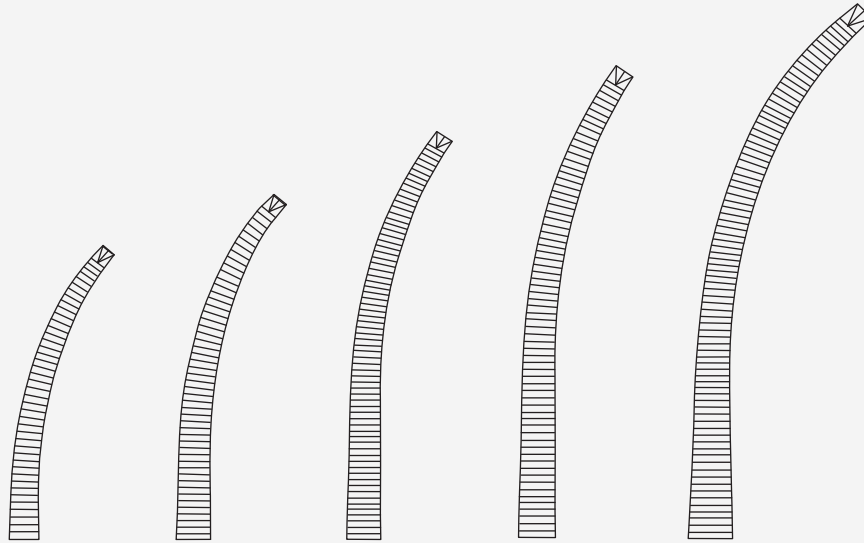

Kocher

06-303-14

14 cm - 5 1/2"  
 1x2

06-304-16

16 cm - 6 1/4"  
 1x2

06-305-18

18 - cm 7"  
 1x2

06-306-20

20 - cm 8"  
 1x2

06-307-22

22 cm - 8 3/4"  
 1x2

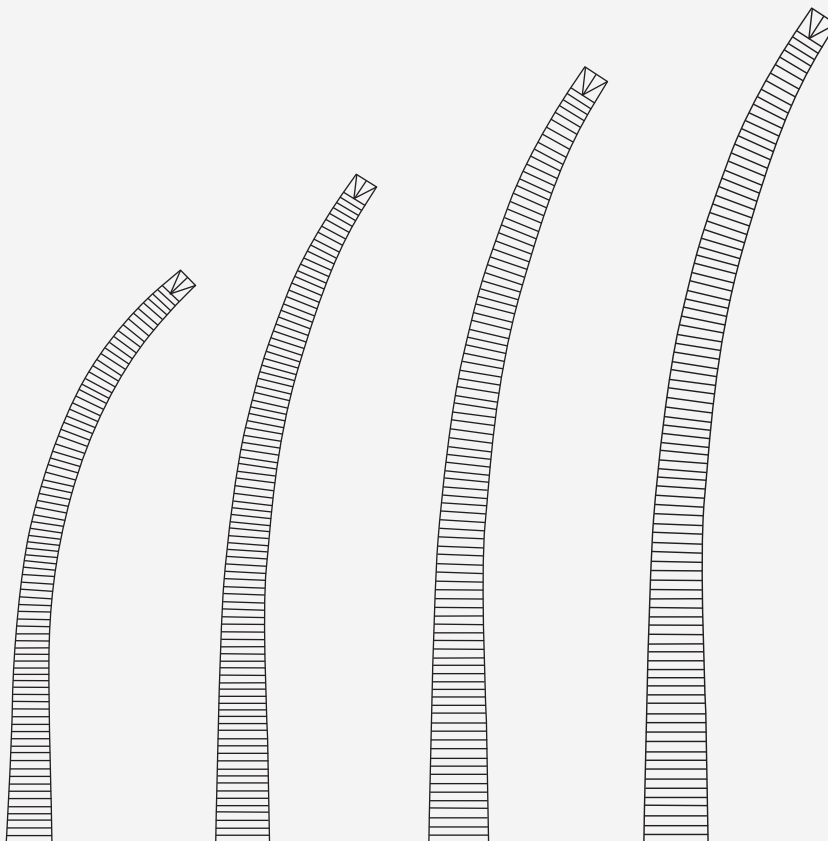

06-308-24

24 cm - 9 1/2"  
 1x2

06-309-26

26 cm - 10 1/4"  
 1x2

06-310-30

30 cm - 12"  
 1x2

06-311-35

35 cm - 14"  
 1x2



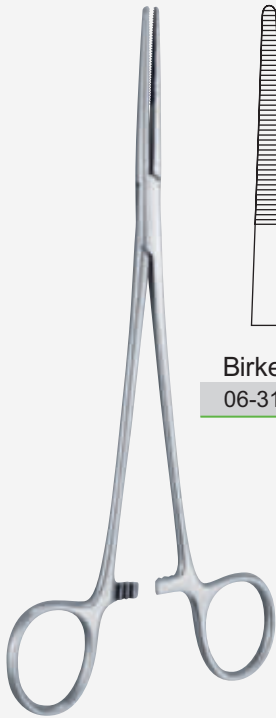

**Birket**

06-312-19

06-313-19

19 cm - 7 1/2"

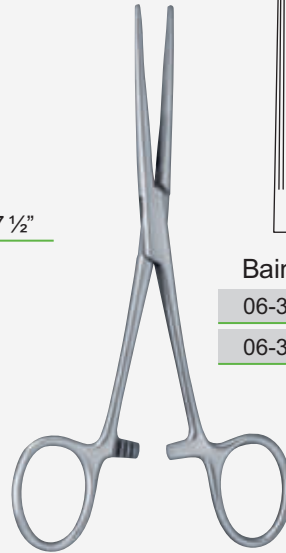
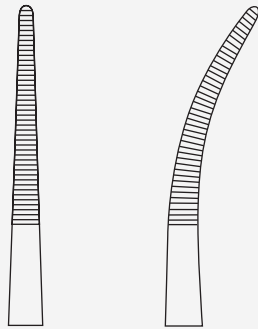

**Bainbridge**

06-314-15

06-315-15

15 cm - 6"

06-314-18

06-315-18

18.5 cm - 7 1/4"

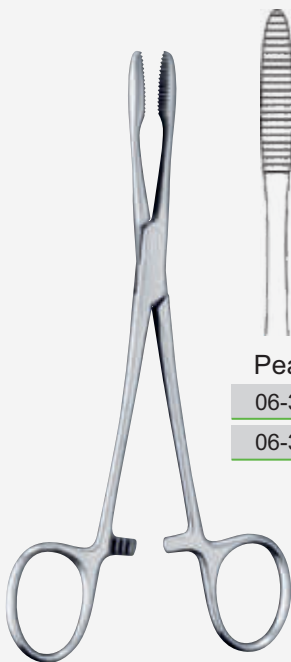
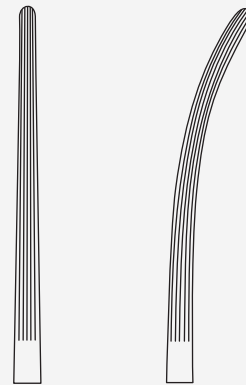

**Pean**

06-316-14

14 cm - 5 1/2"

06-316-22

16 cm - 6 1/4"

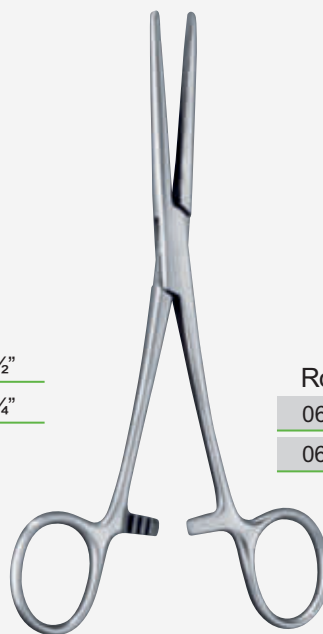

**Rochester-Carmalt**

06-317-16

06-318-16

16 cm - 6 1/4"

06-317-20

06-318-20

20 cm - 8"

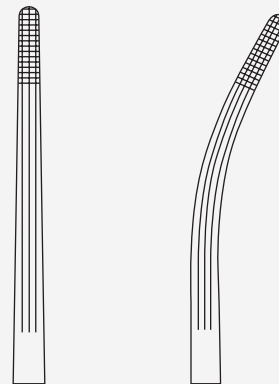



Chaput

06-319-13 13 cm - 5"



Tuffier

06-320-13 13 cm - 5"



Pennington

06-321-15 15.5 cm - 6"

06-321-20 20 cm - 8"



Duval

06-322-14 14 cm - 5 1/2"



Pratt

06-323-15 15 cm - 6"



Martel

06-324-14 14 cm - 5 1/2"



Bengolea

06-337-20	06-338-20	06-339-20	06-340-20	20 cm - 8"
06-337-26	06-338-26	06-339-26	06-340-26	26 cm - 10 1/4"
		1x2	1x2	



Adson

06-341-18	06-342-18	06-343-18	06-344-18	18.5 cm - 7 1/4"
		1x2	1x2	

1:2

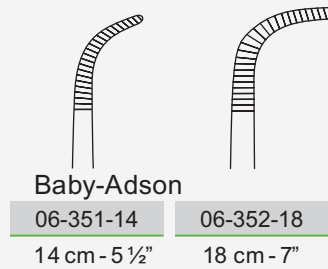
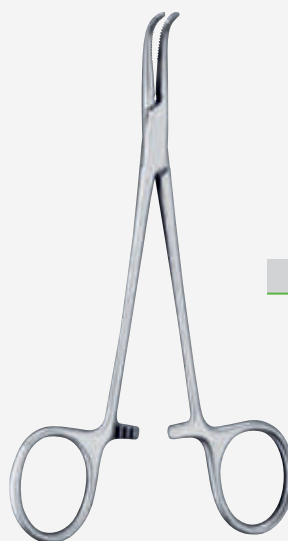
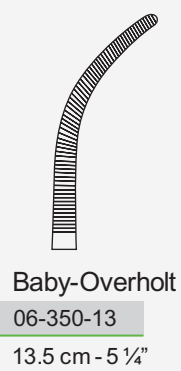
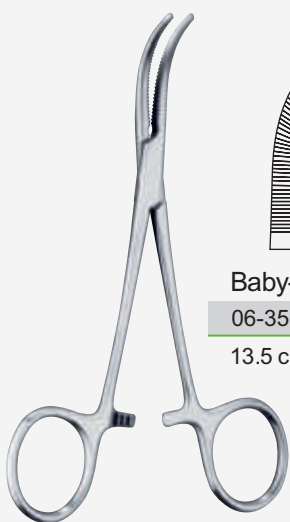
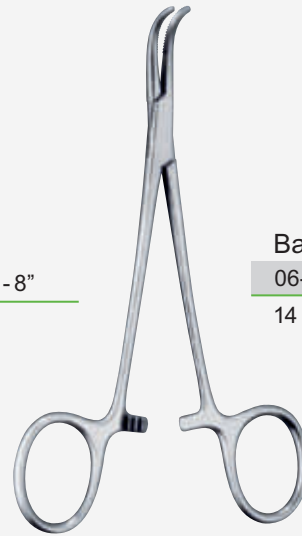
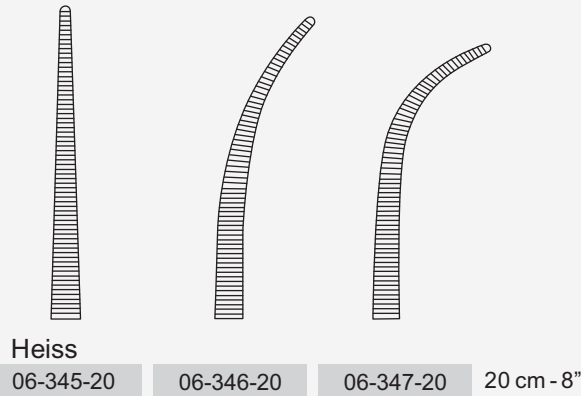
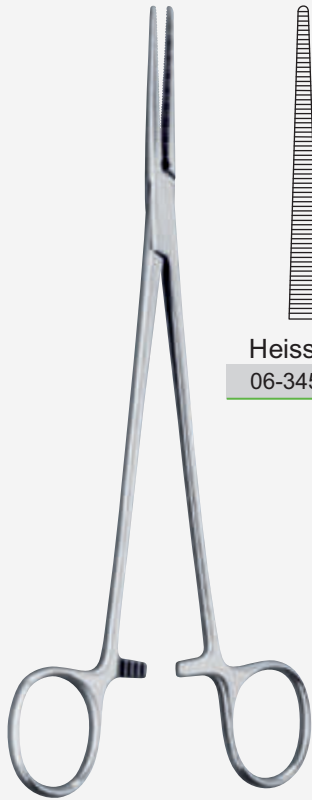

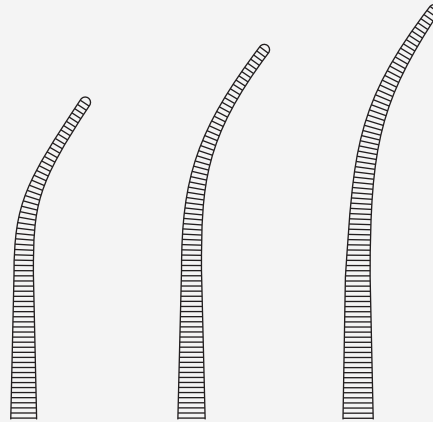

**Kelly-Fraser**

06-353-19

06-354-22

06-355-24

Fig. 1  
19.5 cm - 7 3/4"

Fig. 1  
22 cm - 8 3/4"

Fig. 1  
24 cm - 9 3/4"

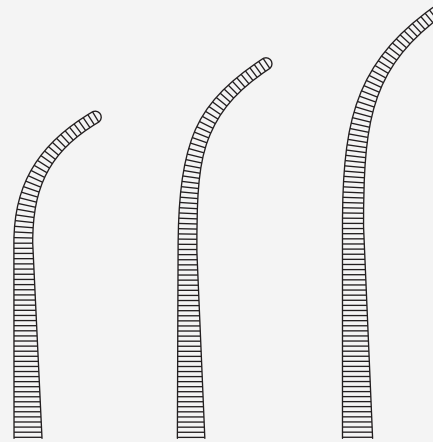

**Kelly-Fraser**

06-356-19

06-357-22

06-358-24

Fig. 2  
19 cm - 7 1/2"

Fig. 2  
22 cm - 8 3/4"

Fig. 2  
24 cm - 9 1/2"

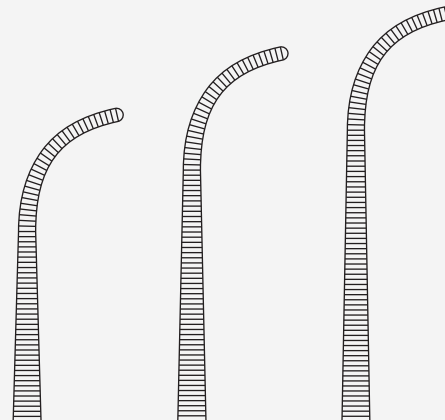

**Kelly-Fraser**

06-359-18

06-360-21

06-361-23

Fig. 3  
18.5 cm - 7 1/4"

Fig. 3  
21.5 cm - 8 1/2"

Fig. 3  
23.5 cm - 9 1/4"

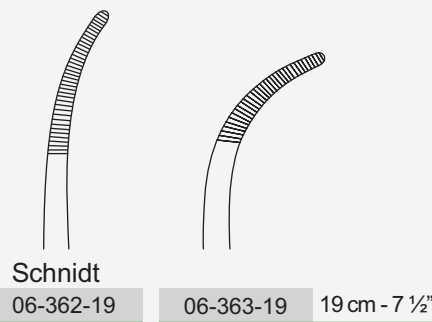
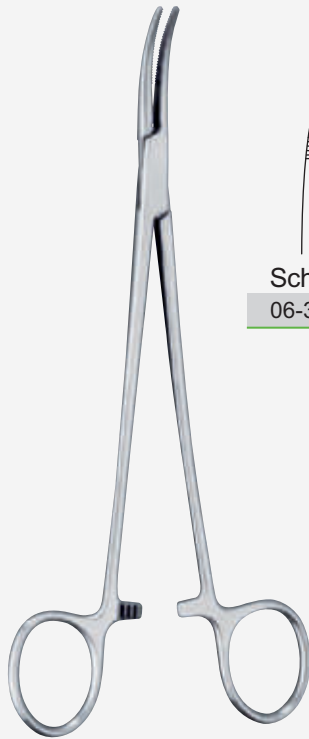

Schmidt

06-362-19

06-363-19

19 cm - 7 1/2"

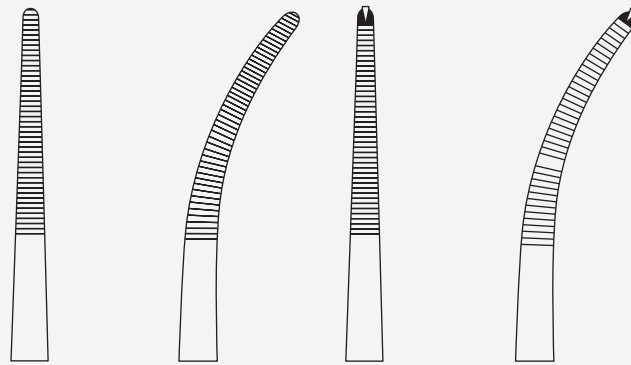
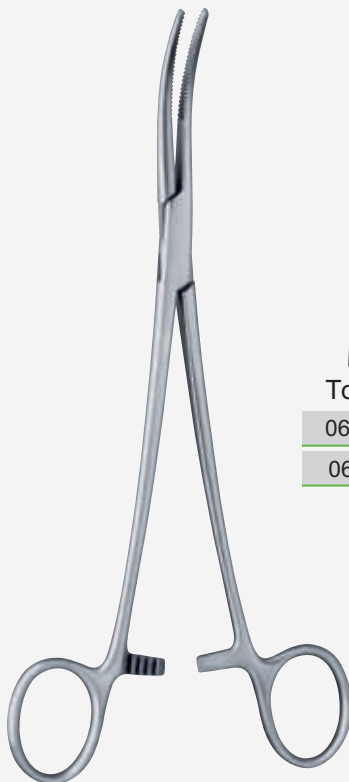

Toennis

06-364-21

06-365-21

06-366-21

06-367-21

21 cm - 8 1/4"

06-364-26

06-365-26

06-366-26

06-367-26

26 cm - 10 1/4"

1x2

1x2



Rumel

06-368-23

Fig. 2

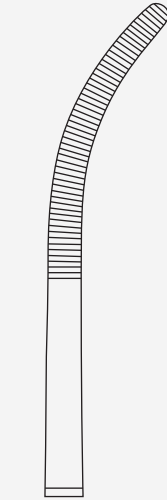
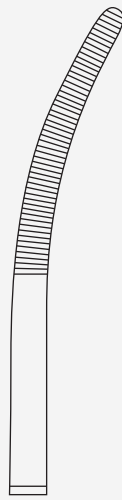

06-369-23

Fig. 2

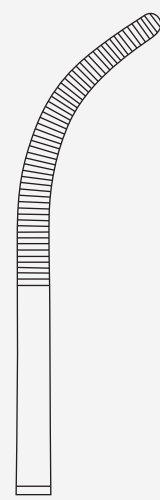

06-370-23

Fig. 3

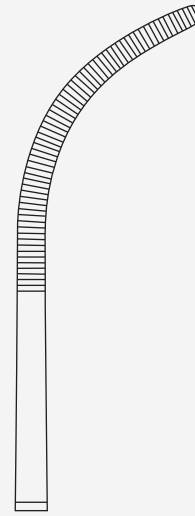

06-371-23

Fig. 4

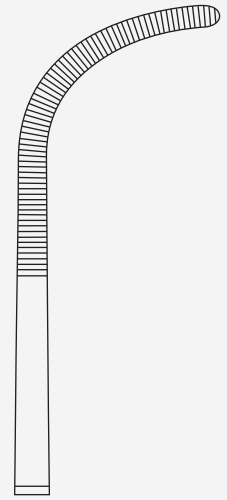

06-372-23

23 cm - 9"

Fig. 5

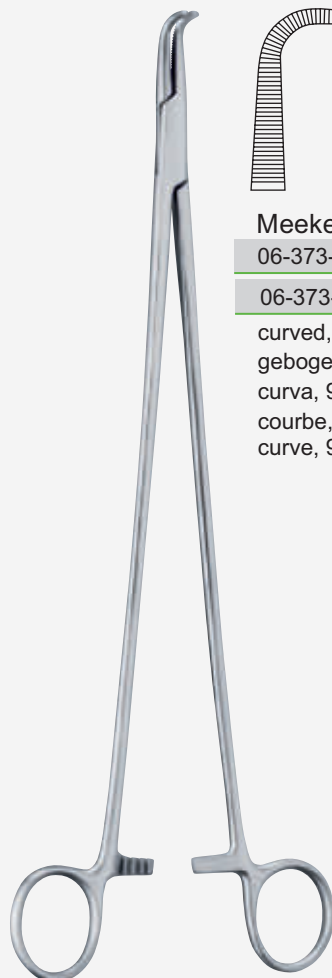

Meeker

06-373-18 18 cm - 7"

06-373-27 27.5 cm - 10 3/4"

curved, 90°  
gebogen, 90°  
curva, 90°  
courbe, 90°  
curve, 90°

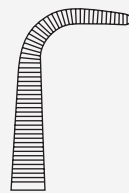

Lawrence

06-374-28

28 cm - 11"

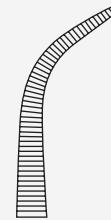



Overholt-Geissendoerfer

06-375-21

06-376-21

06-377-21

06-378-21

21 cm - 8 1/4"

06-375-27

06-376-27

06-377-27

06-378-27

27 cm - 10 3/4"

Fig. 0

Fig. 1

Fig. 2

Fig. 3

06-379-21

06-380-21

06-381-21

21 cm - 8 1/4"

06-379-27

06-380-27

06-381-27

27 cm - 10 3/4"

Fig. 4

Fig. 5

Fig. 6



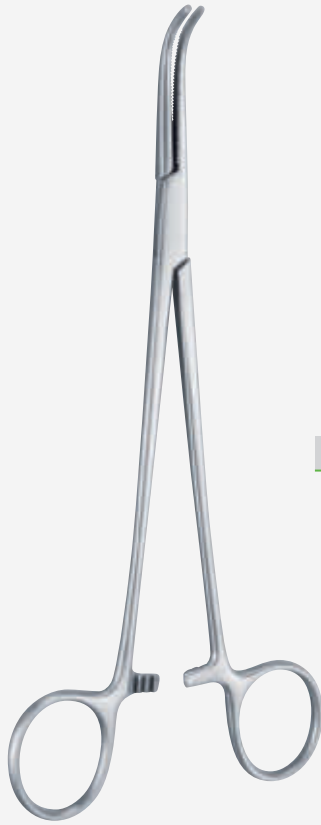

**Overholt- Fino**

06-382-21

Fig. 0

21.5 cm - 8 1/2"

06-383-21

Fig. 1

21 cm - 8 1/4"

06-384-22

Fig. 2

22 cm - 8 3/4"

06-385-23

Fig. 3

23 cm - 9"

06-386-22

Fig. 4

22 cm - 8 3/4"

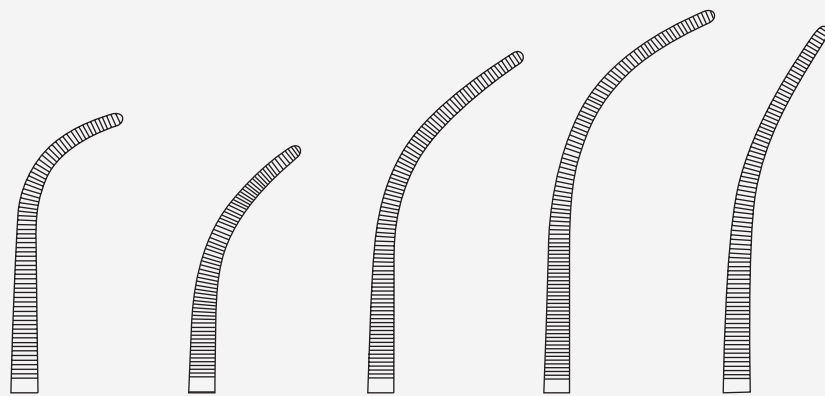

**Overholt**

06-387-29

Fig. 0

29.5 cm - 11 1/2"

06-388-29

Fig. 1

29.5 cm - 11 1/2"

06-389-30

Fig. 2

29.5 cm - 11 1/2"

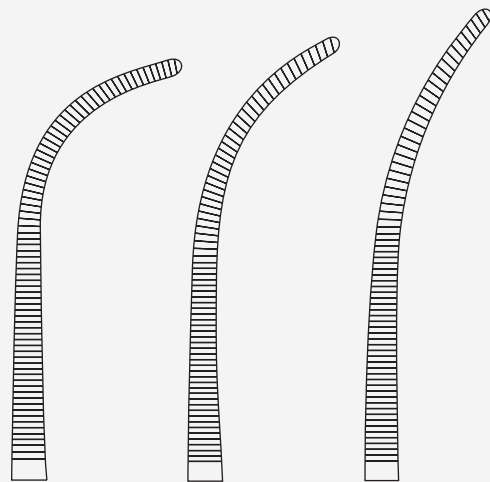

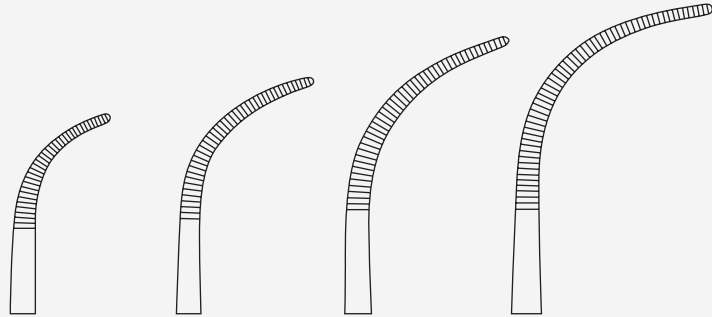

Overholt- Modifiziert

06-390-18

18.5 cm - 7 1/4"

06-391-20

20.5 cm - 8"

06-392-21

21 cm - 8 1/4"

06-393-21

21.5 cm - 8 1/2"

S-curved  
 S-förmig gebogen  
 curva en S  
 courbe en S  
 curve a forma di S



Overholt- Modifiziert

06-394-21

21 cm - 8 1/4"

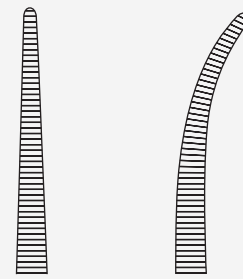
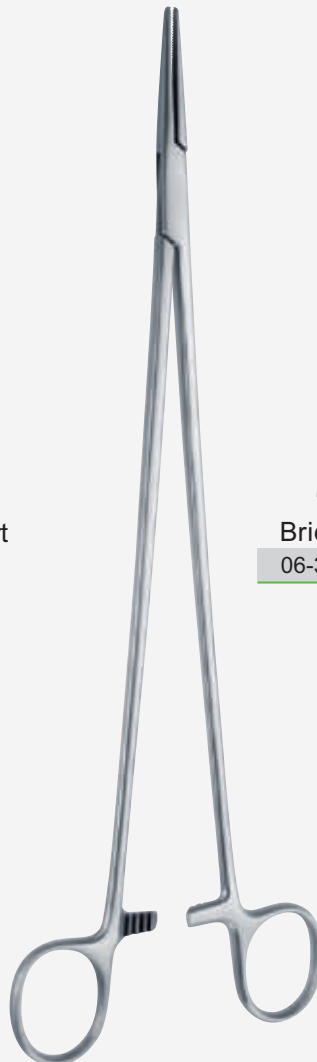

Bridge

06-395-28

06-396-28

28 cm - 11"

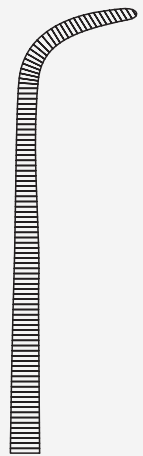
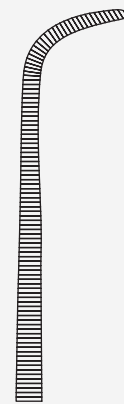
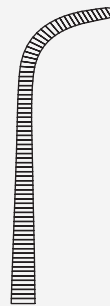
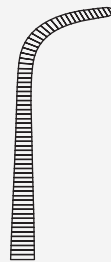
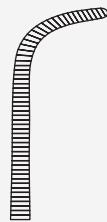
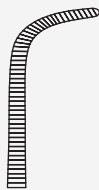
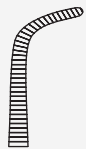

**Gemini**

06-397-13

13 cm - 5"

06-398-16

16 cm - 6 1/4"

06-399-18

18 cm - 7"

06-400-20

20 cm - 8"

06-401-23

23 cm - 9"

06-402-25

25 cm - 9 3/4"

06-403-28

28 cm - 11"

06-404-35

35 cm - 14"



**Mini-Gemini**

06-405-18

18 cm - 7"

06-406-22

22 cm - 8 3/4"

06-407-25

25 cm - 9 3/4"

06-408-28

28 cm - 11"



Zenker

06-408-29

06-409-29A

29.5 cm - 11 1/2"

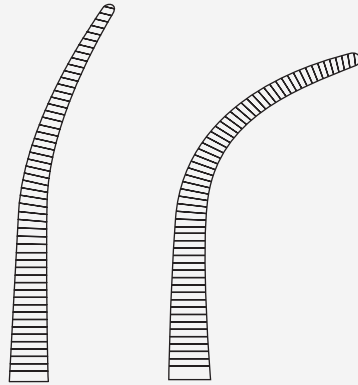

Roberts

06-410-22

06-411-22

22 cm - 8 3/4"

22 cm - 8 3/4"

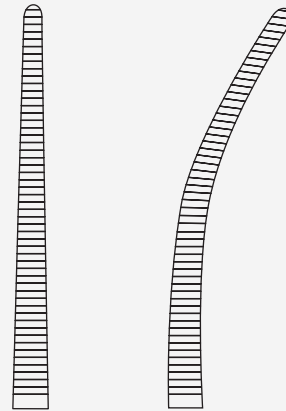

Mixter

06-412-15 15.5 cm - 6"

06-412-19 19 cm - 7 1/2"

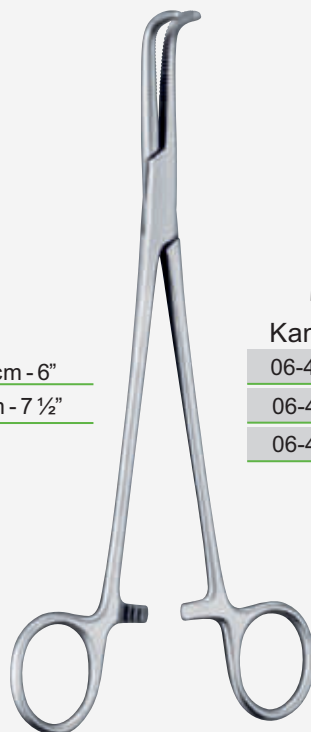
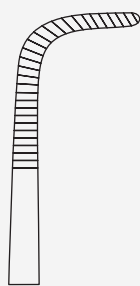

Kantowitz

06-413-19 19 cm - 7 1/2"

06-413-24 24 cm - 9 1/2"

06-413-26 26.5 cm - 10 1/2"

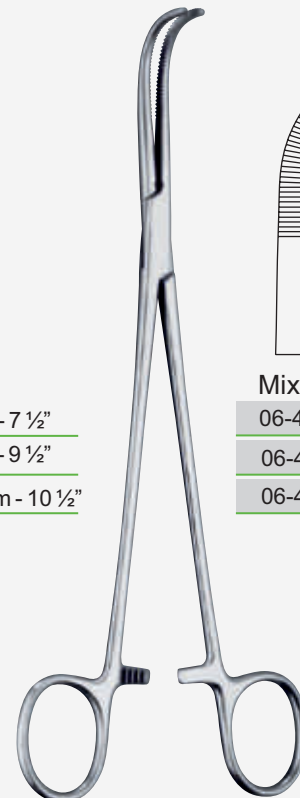
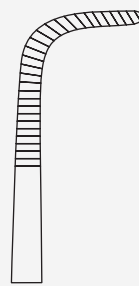

Mixter

06-414-22 22 cm - 8 3/4"

06-414-24 24 cm - 9 1/2"

06-414-35 35 cm - 14"

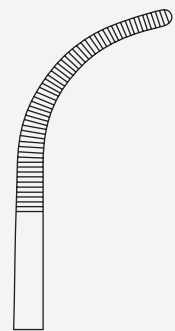

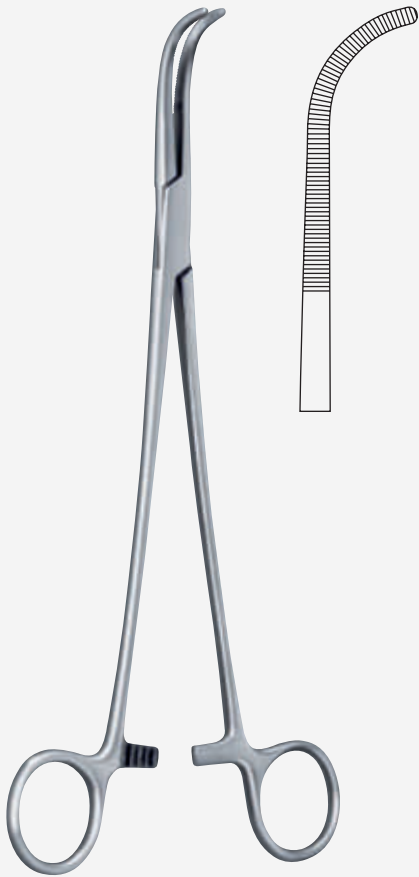

**Mixer**  
06-415-23 23 cm - 9"



**Johns-Hopkins**  
06-416-20 20 cm - 8"

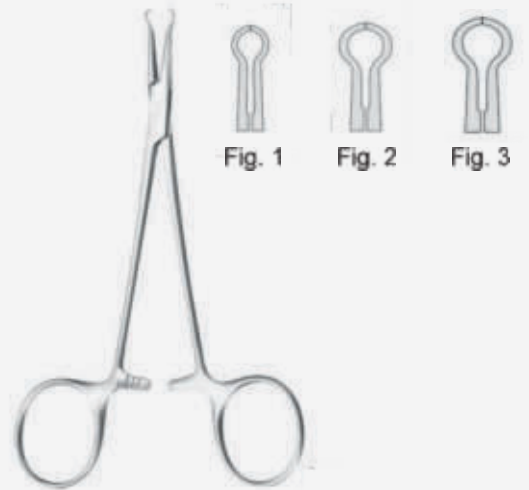

**Vasectomy (Li Ring) Forceps Blunt**

16-203-12 Fig. 1 Ø 3.0 mm

16-204-12 Fig. 2 Ø 3.5 mm

16-205-12 Fig. 3 Ø 4.0 mm  
12.5 cm - 5"

16-206-14 Fig. 1 Ø 3.0 mm

16-207-14 Fig. 2 Ø 3.5 mm

16-208-14 Fig. 3 Ø 4.0 mm  
14 cm - 5½"



**Vasectomy  
Forceps Sharp**  
16-209-12 12.5 cm - 5"



**Mixer-  
O'Shaugnessy**  
06-417-19 19 cm - 7½"



**Wickström**  
06-418-21 21 cm - 8¼"  
06-418-24 24 cm - 9½"

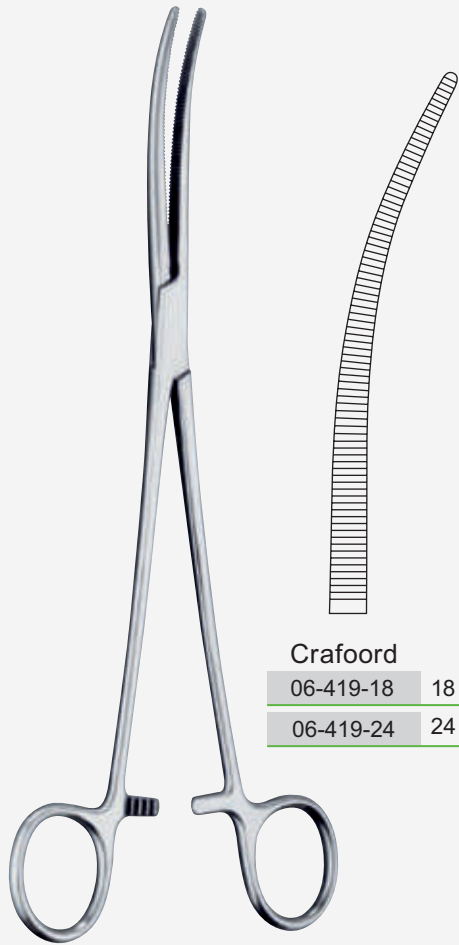

**Crafoord**

06-419-18	18 cm - 7"
06-419-24	24 cm - 9½"

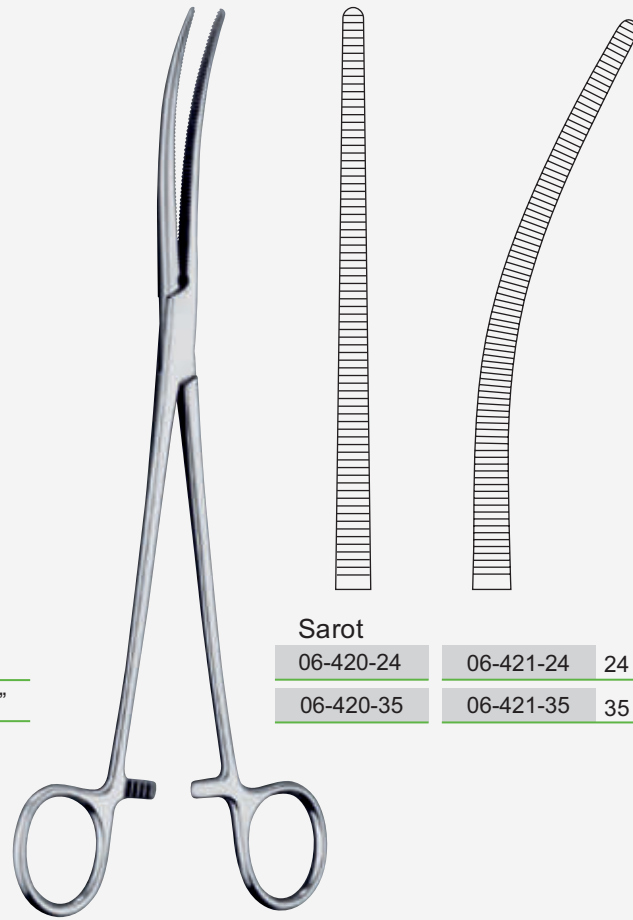

**Sarot**

06-420-24	06-421-24	24 cm - 9½"
06-420-35	06-421-35	35 cm - 14"



**Dean-Shoulder**

06-422-18	18 cm - 7"
-----------	------------



**Negus**

06-423-19	06-424-19	19 cm - 7½"
-----------	-----------	-------------



Lower

06-425-18

18 cm - 7"



Lahey

06-426-19 19 cm - 7 1/2"

06-426-23 23 cm - 9"

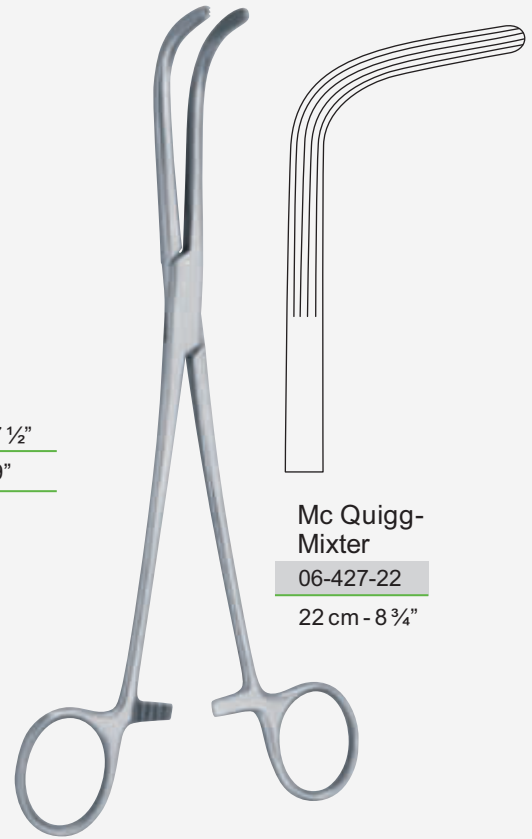

Mc Quigg-Mixer

06-427-22

22 cm - 8 3/4"

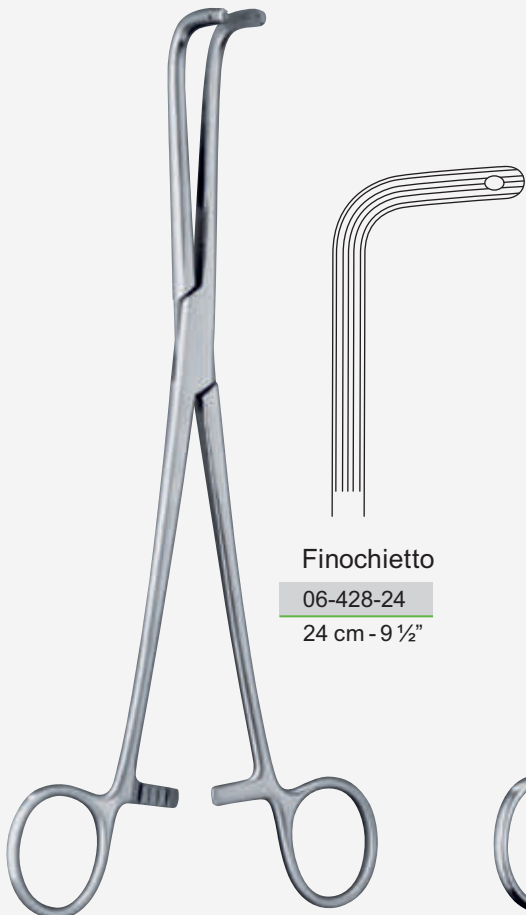

Finochietto

06-428-24

24 cm - 9 1/2"



Mixer

06-429-22

22 cm - 8 3/4"

06-430-25

25 cm - 9 3/4"

06-431-28

28 cm - 11"

Kidney pedicle and gall duct forceps  
 Gallenkanal- und Nierenstielklemmen  
 Pinzas para pediculos renales y conductos biliares  
 Pincas pour pédicules renaux et voies biliaires  
 Pinze per peduncoli renali e vie biliari

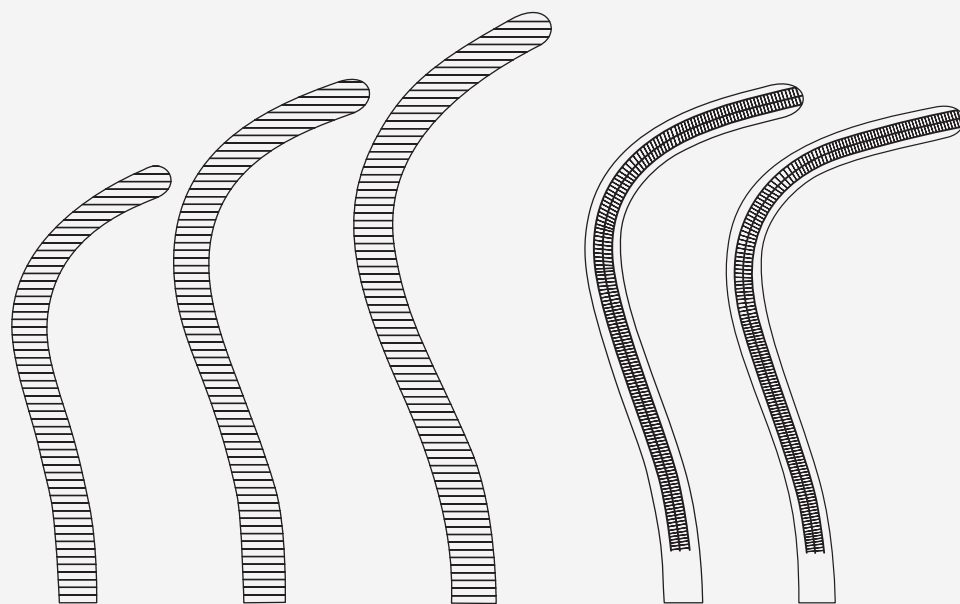

**Guyon**

06-432-20  
 20 mm - 8"

06-433-22  
 22 cm - 8 3/4"

06-434-24  
 24 cm - 9 1/2"

06-435-23  
 23 cm - 9"

06-436-23  
 23 cm - 9"

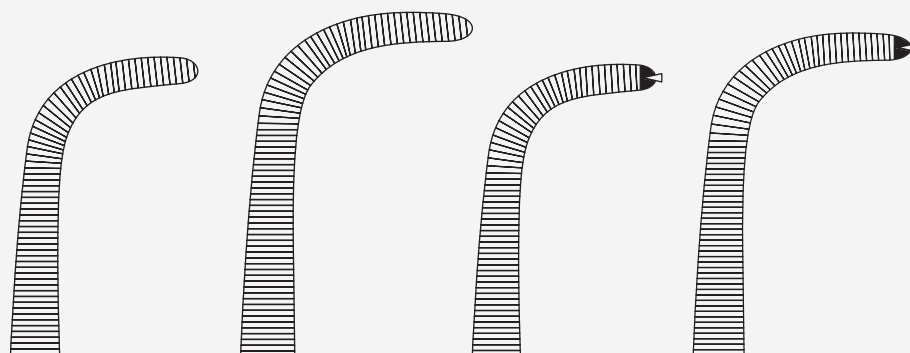
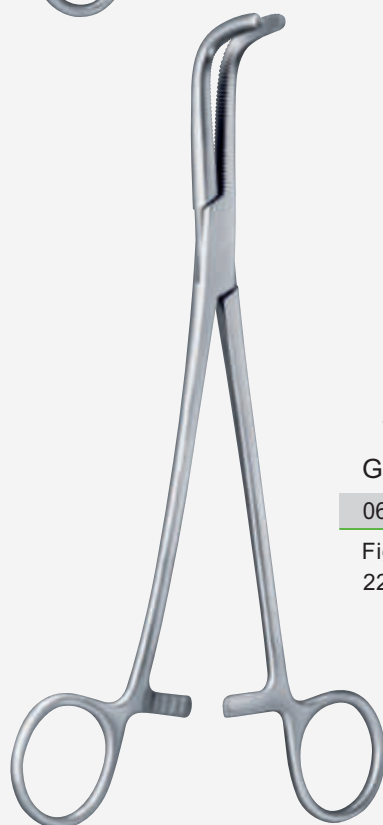

**Gray**

06-437-22  
 Fig. 1  
 22 cm - 8 3/4"

06-438-23  
 Fig. 2  
 23 cm - 9"

06-439-22  
 1x2  
 Fig. 1  
 22 cm - 8 3/4"

06-440-23  
 1x2  
 Fig. 2  
 23 cm - 9"



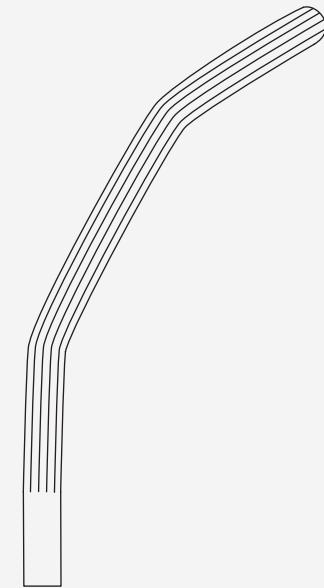

Herrick  
06-441-23  
23 cm - 9"

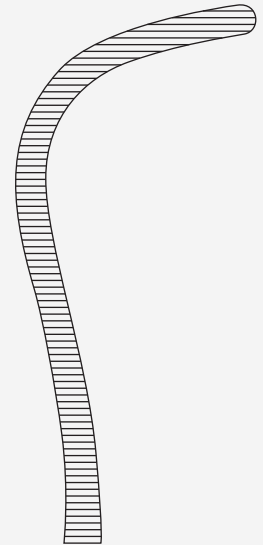

Guyon  
06-442-23  
23 cm - 9"

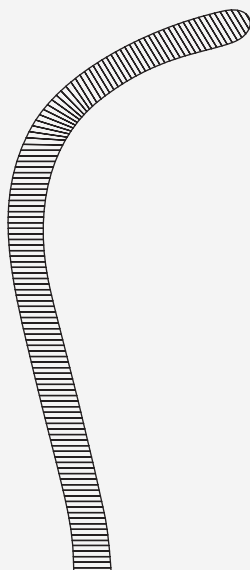

Mayo-  
Guyon  
06-443-23  
23 cm - 9"

Peritoneal forceps  
 Klemmzangen – Peritoneumklemmen  
 Pinzas-clamps – Pinzas para peritoneo  
 Pincers-clamps – Pincers pour le péritoine  
 Pinze per peritoneo

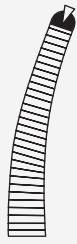

**Faure**  
 06-444-20  
 20 cm - 8"  
 1x2

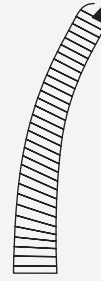
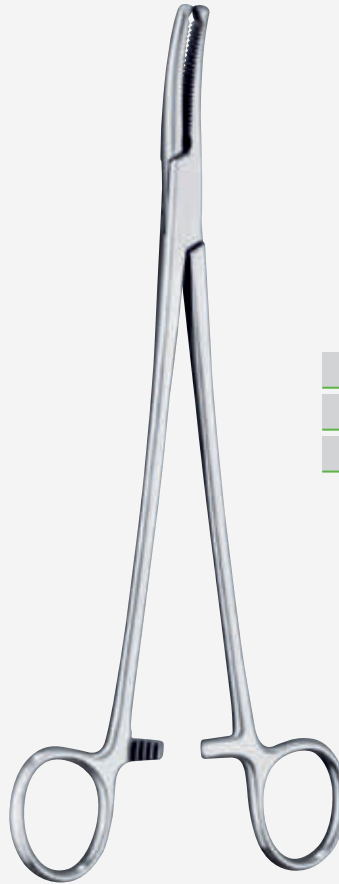

**Wertheim**  
 06-445-22 22 cm - 8 3/4"  
 06-445-23 23 cm - 9"  
 06-445-35 35 cm - 13 3/4"  
 1x2

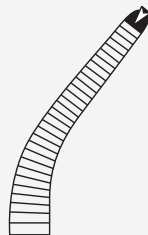
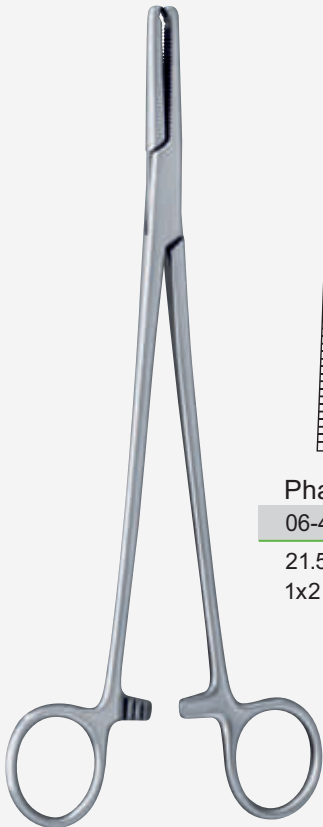

**Phaneuf**  
 06-446-21 21.5 cm - 8 1/2"  
 1x2  
 06-447-21 21.5 cm - 8 1/2"  
 1x2

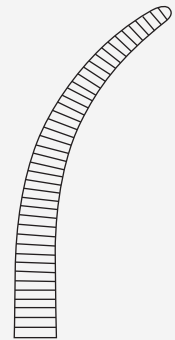
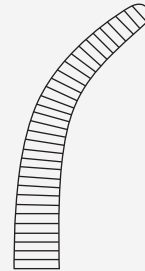

**Moynihan**  
 06-448-23 23 cm - 9"  
 06-449-24 24 cm - 9 1/2"



**Baby- Mikulicz**  
06-450-14 14 cm - 5 ½"  
1x2

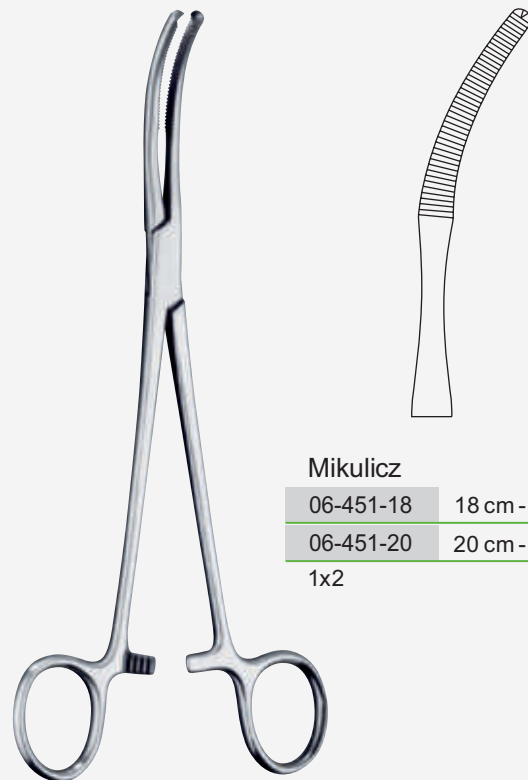

**Mikulicz**  
06-451-18 18 cm - 7"  
06-451-20 20 cm - 8"  
1x2

Clamp forceps – Peritoneal forceps  
Klemmzangen – Peritoneumklemmen  
Pinzas-clamps – Pinzas para peritoneo  
Pinces-clamps – Pinces pour le péritoine  
Pinze per peritoneo

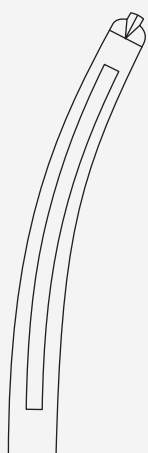

Maingot

06-452-20 20.5 cm - 8"

06-452-25 25 cm - 9 3/4"

1x2

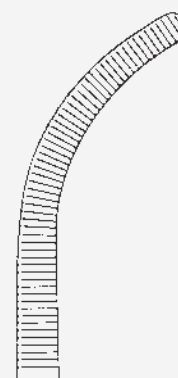
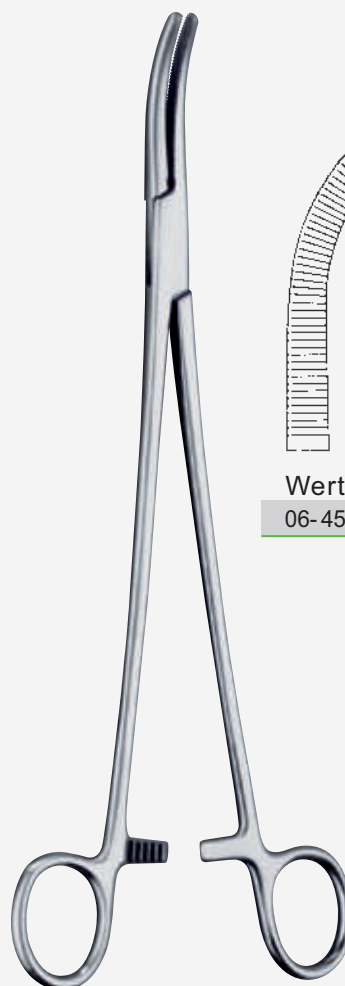

Wertheim

06-453-25 25 cm - 9 3/4"

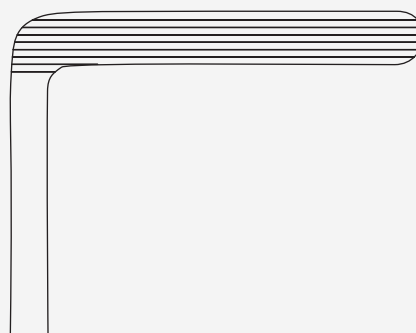

Wertheim-  
Cullen

06-454-21 21.5 cm - 8 1/2"

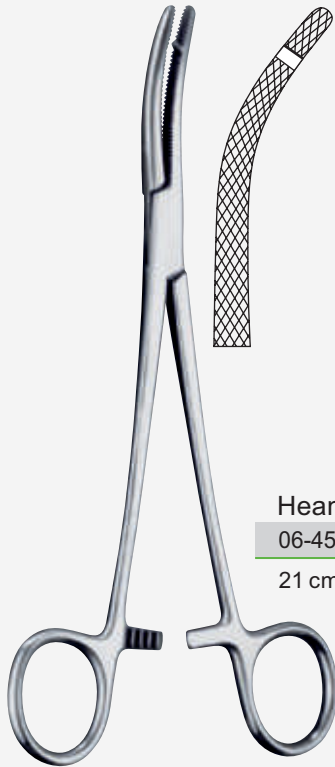

Heaney  
06-455-21  
21 cm - 8 1/4"

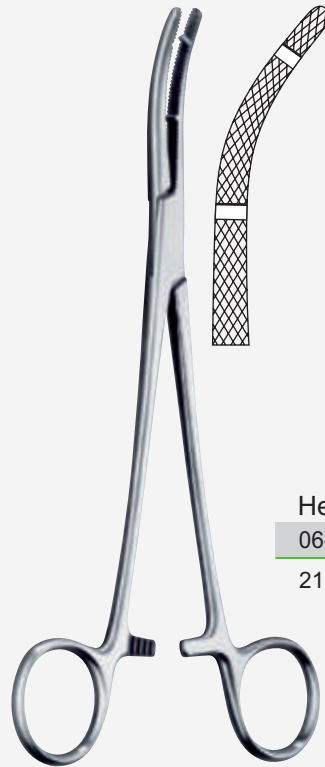

Heaney  
06-456-21  
21 cm - 8 1/4"

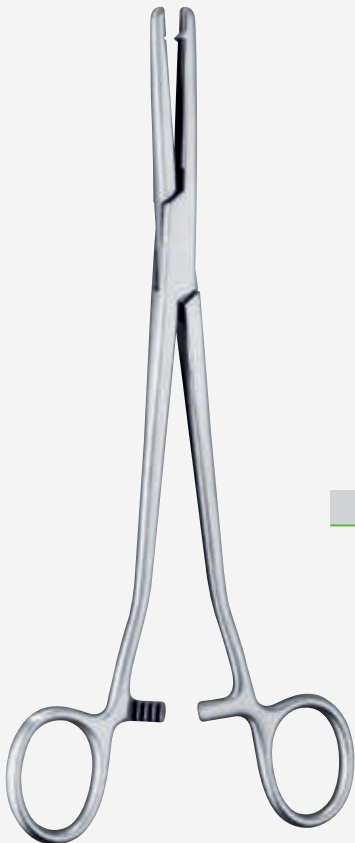

Heaney-  
Ballantine  
06-457-21

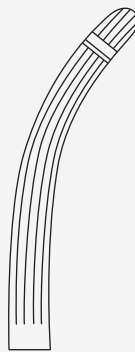

06-458-21 21 cm - 8 1/4"

Lung grasping forceps  
Lungenfasszangen  
Pinzas para coger pulmones  
Pinces-clamps pour poumons  
Pinza per afferrare il polmone

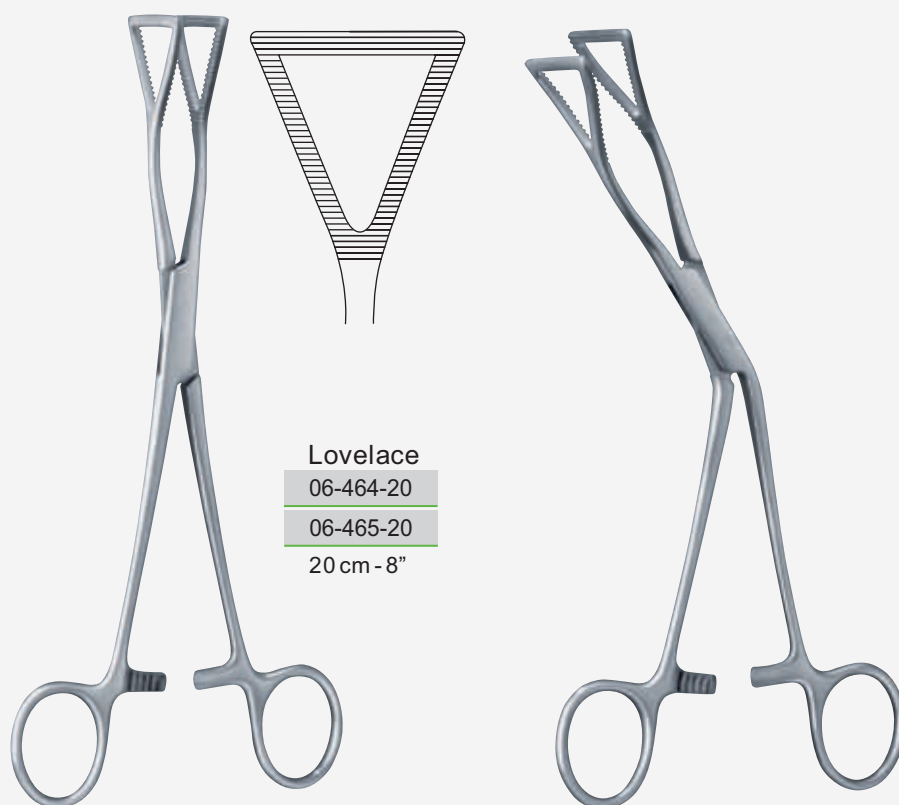

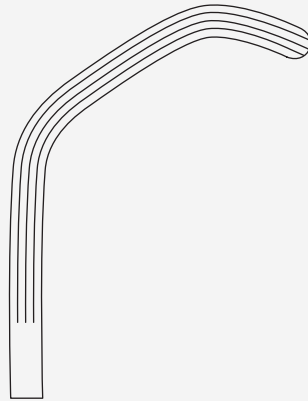
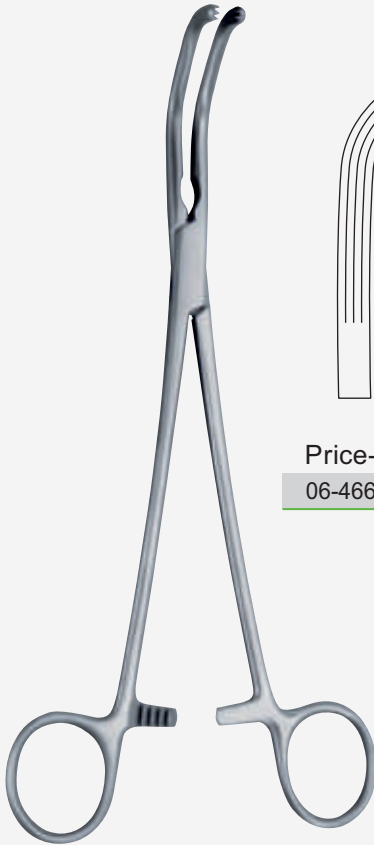

Price-Thomas

06-466-22 22 cm - 8 3/4"

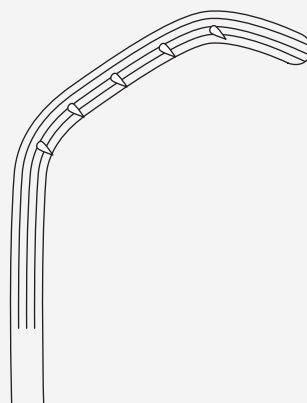

Price-Thomas

06-467-22

Pins left  
Stifte links  
Pernos izquierda  
Goupilles à gauche  
Perni a sinistra

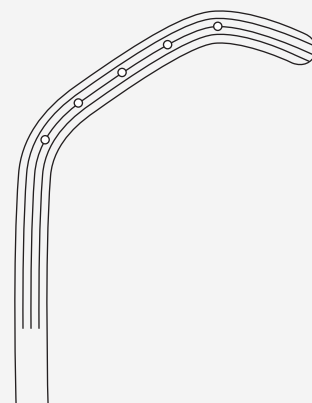

Price-Thomas

06-468-22 22 cm - 8 3/4"

Pins right  
Stifte rechts  
Pernos derecha  
Goupilles à droit  
Perni a destra

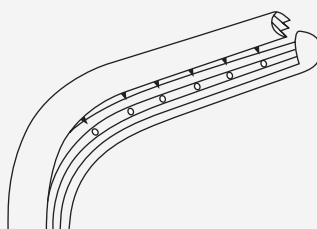

**Sarot**

06-469-23

23 cm - 9"

Pins left

Stifte links

Pernos izquierda

Goupilles à gauche

Perni a sinistra

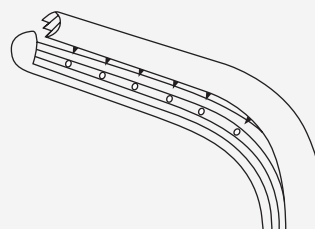

06-470-23

23 cm - 9"

Pins right

Stifte rechts

Pernos derecha

Goupilles à droit

Perni a destra

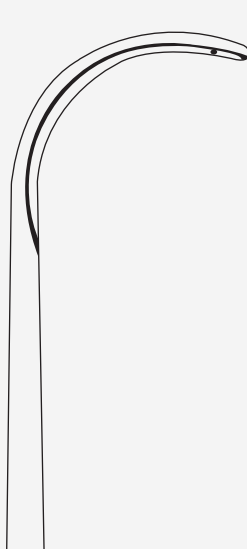

**Semb**

06-471-24

24 cm - 9 1/2"



06-472-24

24 cm - 9 1/2"



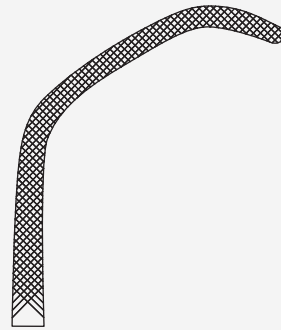

**Baby- Satinsky**

06-473-15 15 cm - 6"

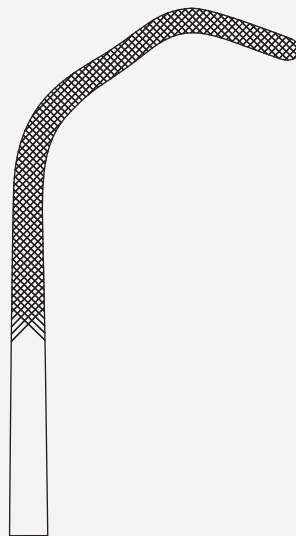

**Satinsky**

06-474-26

Fig. 1

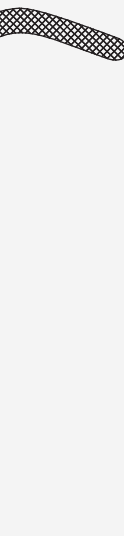

06-475-26

Fig. 1

S-curved  
S-förmig gebogen  
curva en S  
courbe en S  
curva a forma di S

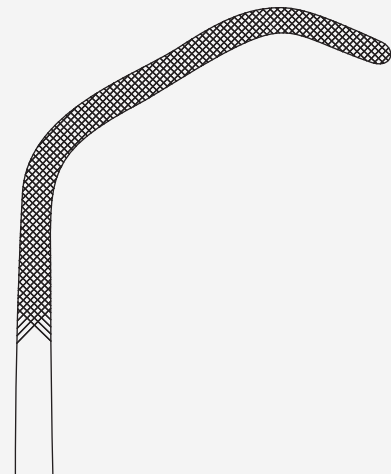

06-476-26

Fig. 2

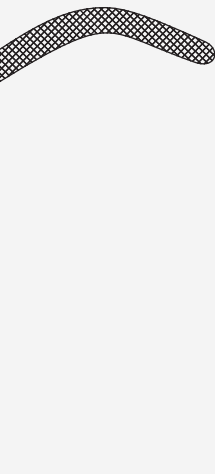

06-477-26

26.5 cm - 10 1/2"

Fig. 2

S-curved  
S-förmig gebogen  
curva en S  
courbe en S  
curva a forma di S

ovel forceps  
 Tuchklemmen  
 Pinzas de campo  
 Pincés à champs  
 Pinze fissateli



**Bernhard**

06-478-10	10 cm - 4"
06-478-12	12 cm - 4 ¾"
06-478-14	14 cm - 5 ½"
06-478-16	16.5 cm 6 ½"
06-478-18	18 cm - 7"



**Backhaus**

06-479-09	9 cm - 3 ½"
06-479-11	11 cm - 4 ¼"
06-479-13	13 cm - 5"
06-479-15	15 cm - 6"



**Roeder**

06-480-13	13 cm - 5"
06-480-15	15 cm - 6"



**Towel**

06-481-11 11 cm - 4"

with clip for tube  
mit Schlauchhalter  
con soporte de tubo  
avec porte-tuyeau  
con supporto per tubo



**Robin**

06-482-13 13.5 cm - 5 ¼"

with clip for tube up to 5 mm Ø  
mit Schlauchhalter bis 5 mm Ø  
con soporte de tubo hasta 5 mm Ø  
avec porte-tuyeau à 5 mm Ø  
con supporto per tubo fino a 5 mm Ø



**Jones**

06-483-05 5 cm - 2"

06-483-09 9 cm - 3 ½"



**Schaedel**

06-484-09 9 cm - 3 ½"



Doyen

06-485-18

18 cm - 7"



Lorna

06-486-10 10 cm - 4"

06-486-13 13 cm - 5"



Lane

06-487-13 13 cm - 5"

06-487-15 15 cm - 6"

06-487-20 20 cm - 8"





Tohoku-Japan

06-488-10 10 cm - 4"

06-488-13 13 cm - 5"



Peers-Bertram

06-489-14 14.5 cm - 5 ¾"



Ball & Socket

06-490-11 11.5 cm - 4 ½"

06-490-14 14 cm - 5 ½"

für Papierabdeckung  
for paper clothes  
pour couvertures en papier  
para paños de papel  
per copertura di carta



Tube

06-491-15 15 cm - 6"

06-491-16 16 cm - 6 1/4"

06-491-19 19 cm - 7 1/2"

06-491-24 24 cm - 9 1/2"



Tube - Modified

06-492-15 15 cm - 6"

06-492-16 16 cm - 6 1/4"

06-492-19 19 cm - 7 1/2"

with protection  
mit Schutzbügel  
con protector  
avec protection  
con protettore



Tube - Plain

06-493-16 16.5 cm - 6 1/2"

06-493-18 18 cm - 7"



Klinikum-Berlin

06-494-14

06-495-14 14.5 cm - 5 3/4"

with extra long ratchet  
mit extra langer Sperre  
con cremallera extra larga  
avec crémaillère extra longue  
con cremagliera extra lunga



Gunnar

06-496-18

18.5 cm - 7 1/4"



Cotton Swab Forceps  
Wattestäubchen Pinzette  
Pinzas para hisopos de algodón  
Pinces à coton-tige  
Pinza per cotton fioc

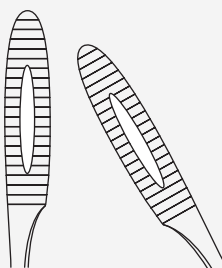

**Gross-Maier**

07-400-20	07-401-20	20 cm - 8"
07-400-22	07-401-22	22 cm - 8 ¾"
07-400-25	07-401-25	25 cm - 9 ¾"
07-400-27	07-401-27	27 cm - 10 ¾"

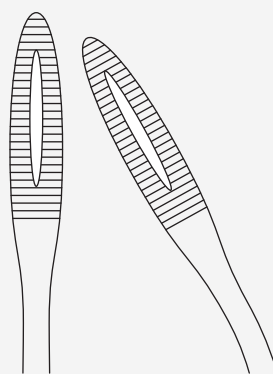

**Maier**

07-402-20	07-403-20	20 cm - 8"
07-402-25	07-403-25	25 cm - 9 ¾"

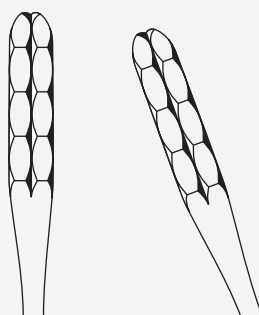

**Ulrich**

07-404-22	07-405-22	22 cm - 8 ¾"
07-404-25	07-405-25	25 cm - 9 ¾"
07-404-27	07-405-27	27 cm - 10 ¾"
07-404-35	07-405-35	35 cm - 14"





Rampley  
06-125-18 18 cm - 7"



06-126-25 25 cm - 9¾"

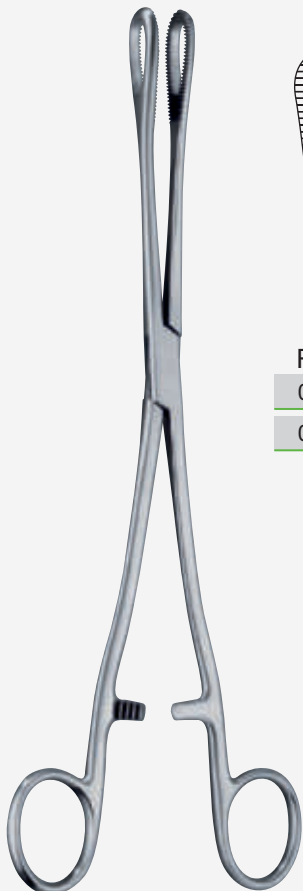

Rampley  
07-406-18 07-407-18 18 cm - 7"  
07-406-25 07-407-25 25 cm - 9¾"

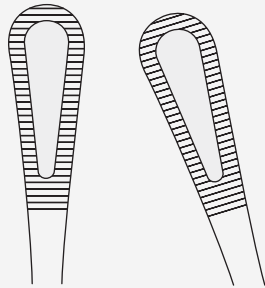

Collin  
07-408-25  
25 cm - 9¾"



Sponge holding forceps  
Schwammzangen  
Pinzas para esponjas  
Pinces à éponges  
Pinze per tamponi

**comed**  
operate better with us

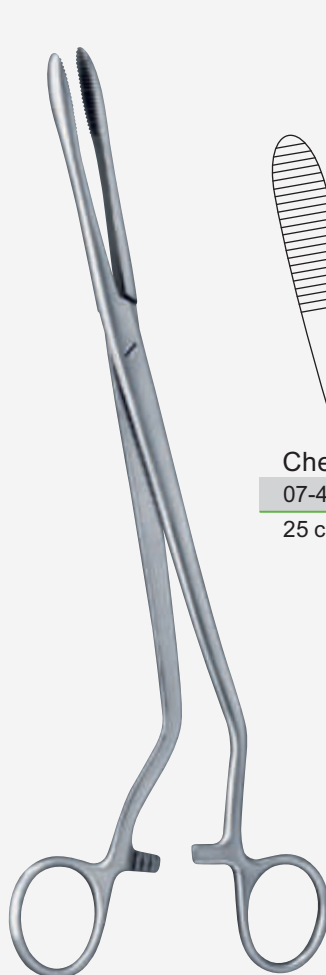

**Cheron**  
07-409-25  
25 cm - 9¾"

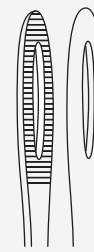
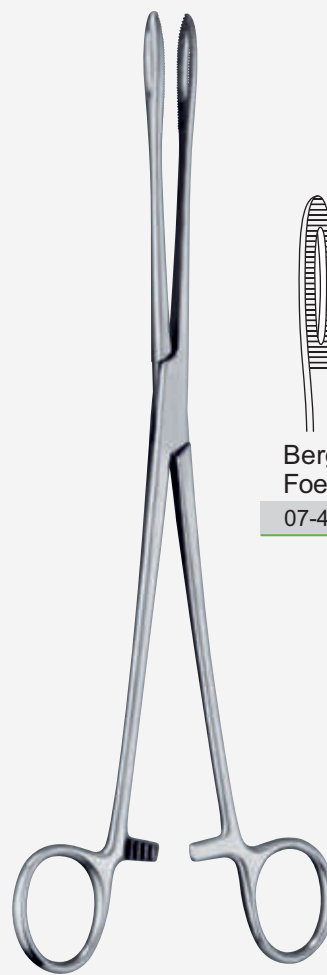

**Bergmann-  
Foerster**  
07-410-25

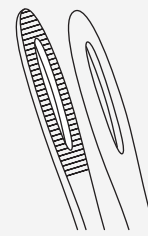

07-411-25 25 cm - 9¾"



Bonney  
17-169-24  
24 cm - 9½"



Foerster (Ballenger)

07-412-18	07-413-18	07-414-18	07-415-18	18 cm - 7"
07-412-20	07-413-20	07-414-20	07-415-20	20 cm - 8"
07-412-25	07-413-25	07-414-25	07-415-25	25 cm - 9¾"
07-412-30	07-413-30	07-414-30	07-415-30	30 cm - 12"

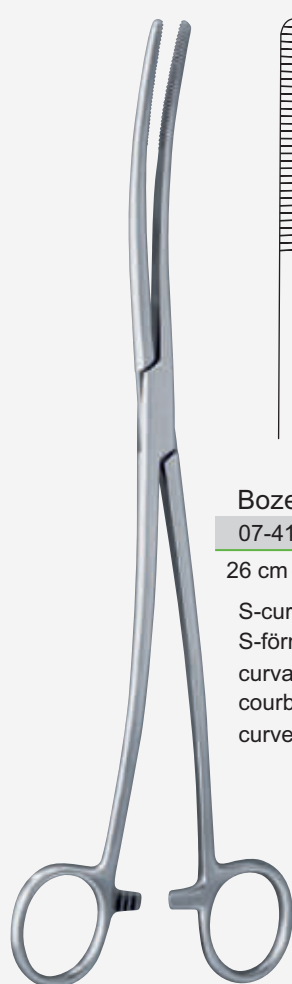

**Bozemann**  
07-416-26

26 cm - 10 1/4"  
S-curved  
S-förmig gebogen  
curva en S  
courbe en S  
curve a forma di S

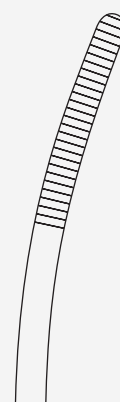
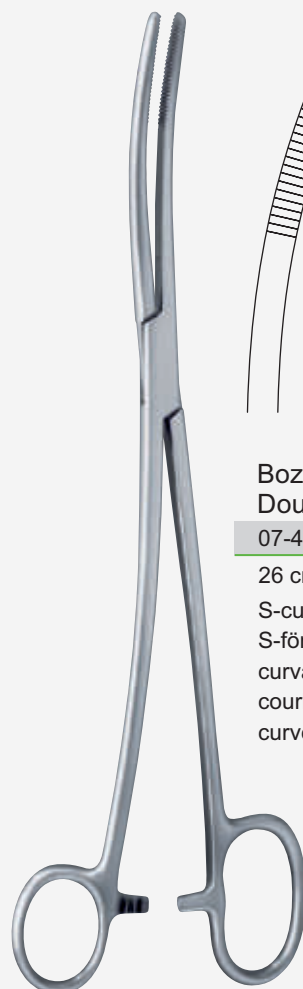

**Bozemann-  
Douglas**  
07-417-26

26 cm - 10 1/4"  
S-curved  
S-förmig gebogen  
curva en S  
courbe en S  
curve a forma di S



Polypus and dressing forceps – Sponge holding forceps  
 Kornzangen – Schwammzangen  
 Pinzas para pólipos y vendajes – para tapones y esponjas  
 Pincers à polypes et à pansements – à tampons et éponges  
 Pinze per medicazione e polipi – Pinze per tamponi



**Bryant**

07-421-13

13 cm - 5"

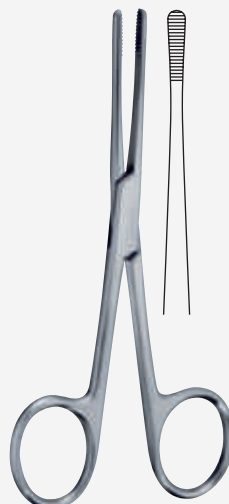

**Lister  
 (Sinus)**

07-422-13 13 cm - 5"

07-422-16 16 cm - 6 ¼"

07-422-18 18 cm - 7"

Sinus forceps  
 Sinusklemmen  
 Pinza para el sinus  
 Pincers à sinus  
 Pinze per seni

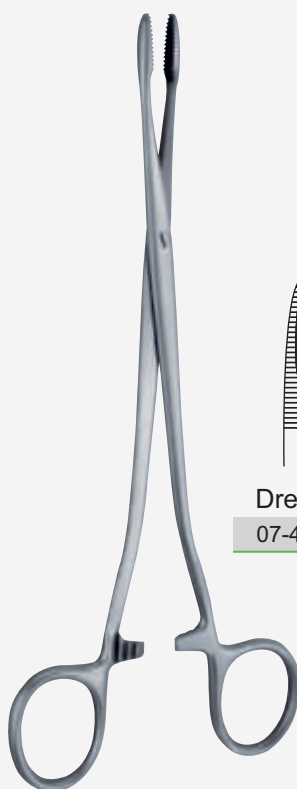

**Dressing**

07-423-20

07-424-20

20 cm - 8"



Retractors  
Wundhaken  
Separadores  
Ecarteurs  
Divaricatori

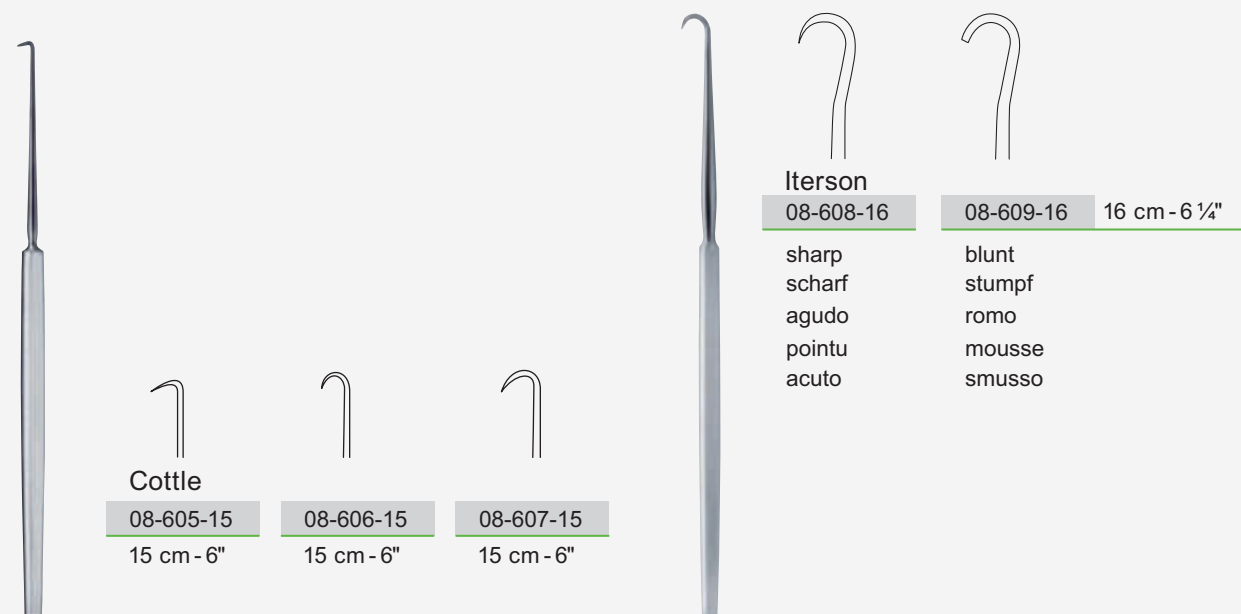



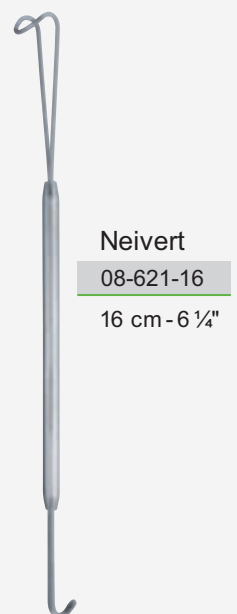
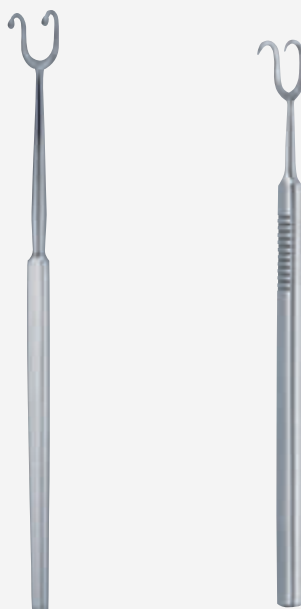
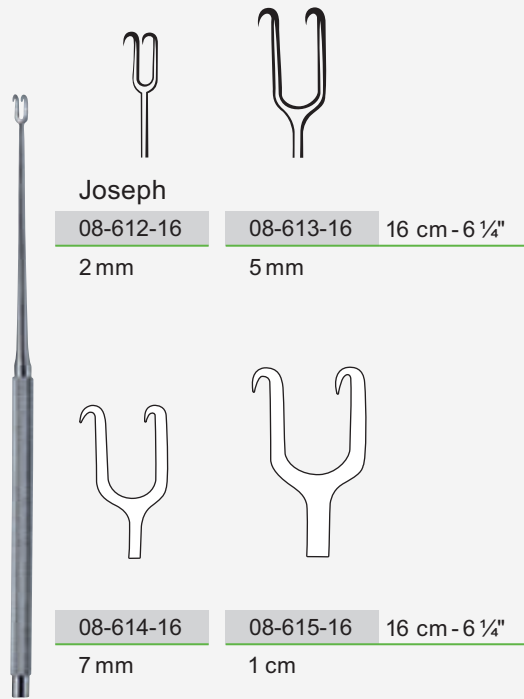
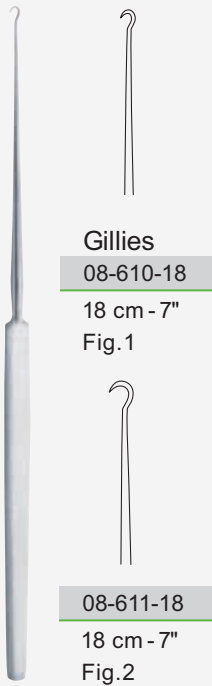



**Cottle**  
 08-622-15

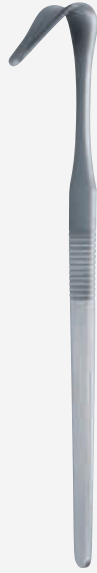

**Cottle - Modified**  
 08-623-15 15 cm - 6"

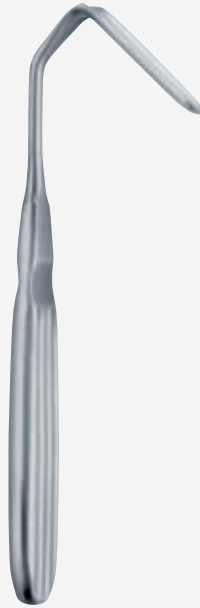

**Aufricht**  
 08-624-19  
 19 cm - 7 1/2"

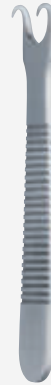

**Kilner**  
 08-625-10  
 10 cm - 4"



**Converse**  
 08-626-12  
 12 cm - 4 3/4"



**Jackson**  
 08-627-15  
 15 cm - 6"



**Lukens**  
 08-628-17  
 17 cm - 6 3/4"  
 blunt  
 stumpf  
 romo  
 mousse  
 smusso



Jackson  
08-629-17  
17 cm - 6 3/4"



Jackson	08-630-18	08-631-18	18 cm - 7"
stumpf		scharf	
blunt		sharp	
mousse		pointu	
romo		agudo	
smusso		acuto	



Rose  
08-632-13  
13 cm - 5"



Luer  
08-633-11  
11 cm - 4 1/4"



Schoenborn  
08-634-21  
21 cm - 8 1/4"

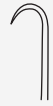

Emmet

08-635-22

Fig.1



08-636-22

Fig.2



08-637-22

Fig.3



08-638-22

Fig.4

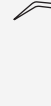

08-639-22

Fig.5

22 cm - 8 3/4"



Davidson

08-640-16

sharp  
scharf  
agudo  
pointu  
acuto



08-641-16



08-642-16



08-643-16

16 cm - 6 1/4"



08-644-16

blunt  
stumpf  
romo  
mousse  
smusso



08-645-16



08-646-16



08-647-16

16 cm - 6 1/4"



**Flexi**

08-648-16A

08-648-16

08-649-16

08-650-16

16 cm - 6 1/4"

flexible, sharp  
flexibel, scharf  
flexible, agudo  
flexible, pointu  
flessibile, acuto



08-651-16A

08-651-16

08-652-16

08-653-16

16 cm - 6 1/4"

flexible, blunt  
flexibel, stumpf  
flexible, romo  
flexible, mousse  
flessibile, smusso



**Desmarres**

08-654-16

08-655-16

08-656-16

16 cm - 6 1/4"

x = 8 mm

x = 1 cm

x = 1.2 cm



08-657-16

08-658-16

08-659-16

16 cm - 6 1/4"

x = 1.4 cm

x = 1.6 cm

x = 1.8 cm



**Knapp  
(Rollet)**

08-660-16

16 cm - 6 1/4"

flexibel, scharf  
flexible, sharp  
flexible, pointu  
flexible, agudo  
flessibile, acuto

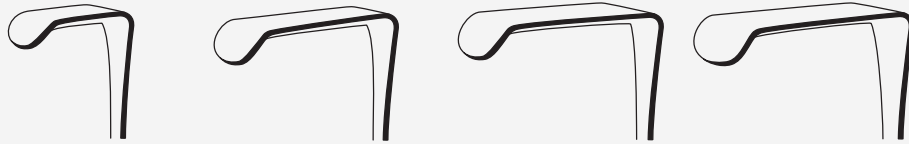
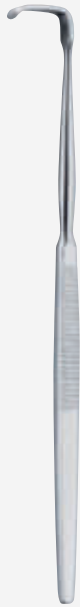

Mini-Langenbeck

08-661-16

10 mm x 6 mm

08-662-16

17 mm x 5 mm

08-663-16

20 mm x 6 mm

08-664-16

16 cm - 6 1/4"

22 mm x 8 mm



Kocher

08-665-22

08-666-22

08-667-22

08-668-22

08-669-22

08-670-22

08-671-22

22 cm - 8 3/4"

sharp  
scharf  
agudo  
pointu  
acuto



08-672-22

08-673-22

08-674-22

08-675-22

08-676-22

08-677-22

08-678-22

22 cm - 8 3/4"

blunt  
stumpf  
romo  
mousse  
smusso



08-679-22

08-680-22

08-681-22

08-682-22

08-683-22

08-684-22

08-685-22

22 cm - 8 3/4"

semi-sharp  
halbscharf  
semi-agudo  
semi-pointu  
semi-acuto



**Volkman**

08-686-21

sharp  
scharf  
agudo  
pointu  
acuto



08-687-21



08-688-21



08-689-21



08-690-21

21.5 cm - 8 1/2"



08-691-21

blunt  
stumpf  
romo  
mousse  
smusso



08-692-21



08-693-21



08-694-21

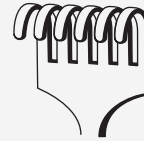

08-695-21

21.5 cm - 8 1/2"



08-696-21

semi-sharp  
halbscharf  
semi-agudo  
semi-pointu  
semi-acuto



08-697-21



08-698-21



08-699-21



08-700-21

21.5 cm - 8 1/2"

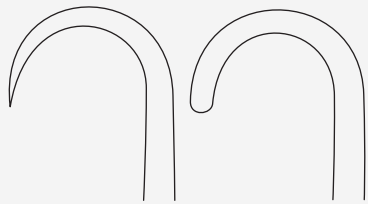

**Volkman**

08-701-21

21.5 cm - 8 1/2"

sharp  
scharf  
agudo  
pointu  
acuto

08-702-21

21.5 cm - 8 1/2"

blunt  
stumpf  
romo  
mousse  
smusso

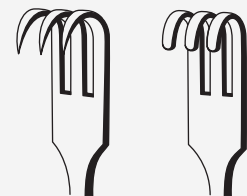

**Senn-Mueller**

08-703-16

16 cm - 6 1/4"

sharp  
scharf  
agudo  
pointu  
acuto

08-704-16

16 cm - 6 1/4"

blunt  
stumpf  
romo  
mousse  
smusso

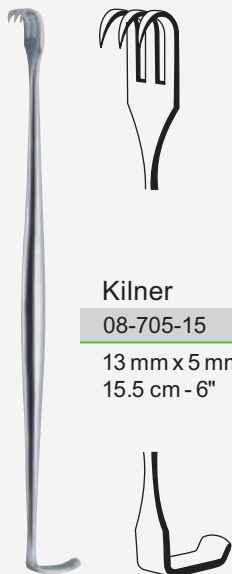

**Kilner**

08-705-15

13 mm x 5 mm  
15.5 cm - 6"

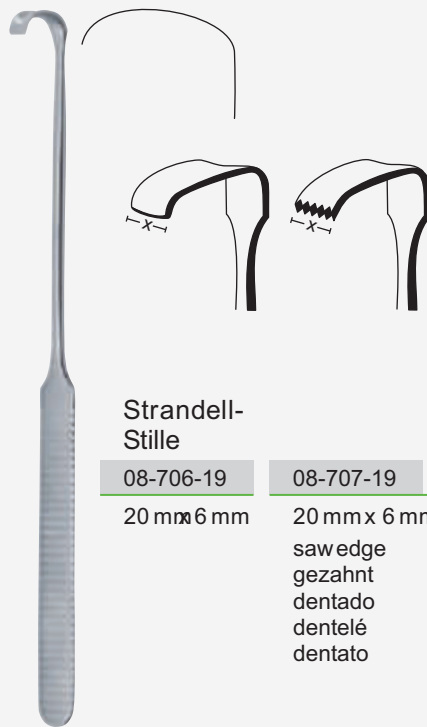

**Strandell-  
Stille**

08-706-19

20 mm x 6 mm

08-707-19

20 mm x 6 mm

saw edge  
gezahnt  
dentado  
dentelé  
dentato

19 cm - 7 1/2"

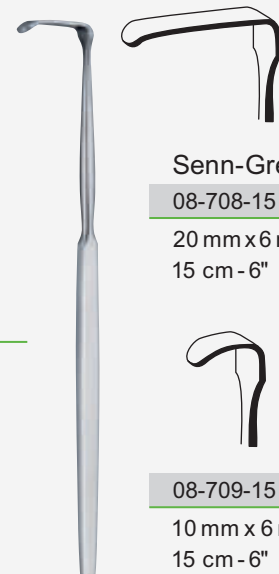

**Senn-Green**

08-708-15

20 mm x 6 mm  
15 cm - 6"

08-709-15

10 mm x 6 mm  
15 cm - 6"





Cottle  
08-711-15  
15 cm - 6"



Crile  
08-712-11  
11 cm - 4 1/4"

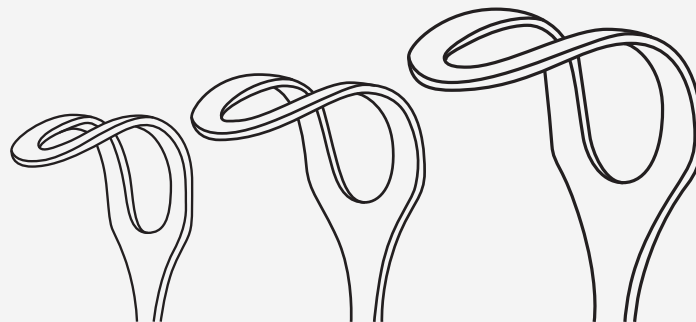

Middeldorpf

08-713-21  
1.4 cm x 1.7 cm  
21.5 cm - 8 1/2"

08-714-22  
2 cm x 2.2 cm  
22 cm - 8 3/4"

08-715-23  
2.6 cm x 3 cm  
23.5 cm - 9 1/4"



Meyerding

08-716-18

18 mm x 7 mm



08-717-18

18 cm - 7"

10 mm x 3 mm



08-718-18

16 mm x 5 mm



08-719-18

18 cm - 7"

7 mm x 4 mm



08-720-18

10 mm x 4 mm



08-721-18

18 cm - 7"

7 mm x 4 mm

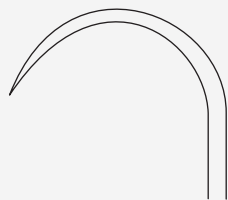

Koerte

08-722-23

26 mm x 40 mm

sharp  
scharf  
agudo  
pointu  
acuto

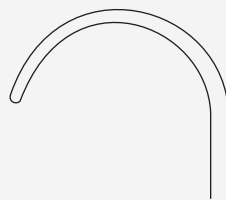

08-723-23

23.5 cm - 9 1/4"

26 mm x 40 mm

blunt  
stumpf  
romo  
mousse  
smusso



Green

08-724-21

21.5 cm - 8 1/2"

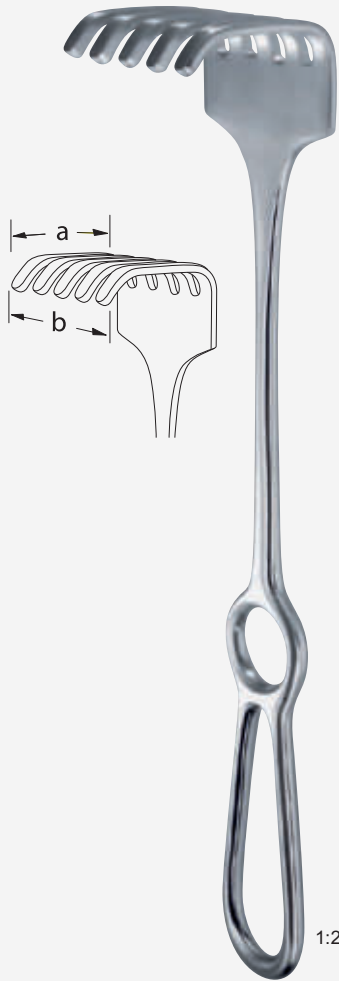

**Israel**

**08-725-25**

a = 4 cm – b = 4 cm

- 4 Teeth
- 4 Zähne
- 4 Dientes
- 4 Dents
- 4 Denti

**08-726-25** 25 cm - 9 3/4"

a = 4.5 cm – b = 5 cm

- 5 Teeth
- 5 Zähne
- 5 Dientes
- 5 Dents
- 5 Denti

**08-727-25**

a = 5 cm – b = 6 cm

- 6 Teeth
- 6 Zähne
- 6 Dientes
- 6 Dents
- 6 Denti

**08-728-25** 25 cm - 9 3/4"

a = 7 cm – b = 7 cm

- 6 Teeth
- 6 Zähne
- 6 Dientes
- 6 Dents
- 6 Denti

**Langenbeck**

**08-729-22**

- Fig.1
- 3 cm x 1.1 cm
- semi-sharp
- halbscharf
- semi-agudo
- semi-pointu
- semi-acuto

**08-730-22**

- Fig.2
- 3 cm x 1.4 cm

**08-731-22** 22 cm - 8 3/4"

- Fig.3
- 3 cm x 1.6 cm

**08-732-22**

- Fig.4
- 4 cm x 1.1 cm

**08-733-22** 22 cm - 8 3/4"

- Fig.5
- 5 cm x 1.1 cm



**Langenbeck**

08-734-21

Fig.1  
3 cm x 1.1 cm  
blunt



08-735-21

Fig.2  
3 cm x 1.4 cm  
blunt



08-736-21

21 cm - 8 1/4"

Fig.3  
3 cm x 1.6 cm  
blunt



08-737-21

Fig.4  
4 cm x 1.1 cm  
blunt

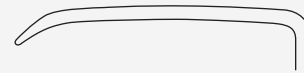

08-738-21

21 cm - 8 1/4"

Fig.5  
5 cm x 1.1 cm  
blunt



08-739-21

2.5 cm x 7 mm



08-740-21

3.5 cm x 8 mm



08-741-21

3.5 cm x 1.1 cm



08-742-21

3.5 cm x 1.5 cm

**Kocher-Langenbeck (Obwegeser)**

21.5 cm - 8 1/2"



08-743-21

4.2 cm x 1 cm



08-744-21

5.5 cm x 1.2 cm

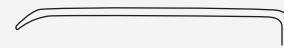

08-745-21

7 cm x 1.4 cm

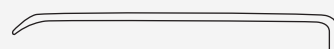

08-746-21

8 cm x 1.2 cm

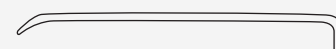

08-747-21

8 cm x 1.6 cm

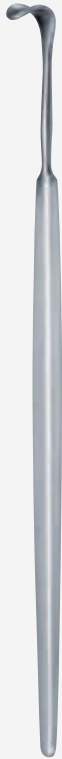

Cushing

08-748-20	08-749-20	08-750-20	08-751-20	08-752-20	08-753-20	20 cm - 8"
08-748-24	08-749-24	08-750-24	08-751-24	08-752-24	08-753-24	24 cm - 9 1/2"
x = 8 mm	x = 1 cm	x = 1.2 cm	x = 1.4 cm	x = 1.6 cm	x = 1.8 cm	



Obwegeser

08-754-22  
4.2 cm x 1.3 cm

08-755-22 22 cm - 8 3/4"  
6 cm x 1.2 cm

08-756-22 22 cm - 8 3/4"  
8 cm x 1.6 cm



Obwegeser

08-757-22

4.4 cm x 9,5 mm

08-758-22 22 cm - 8 3/4"

7 cm x 1,5 cm



Obwegeser

08-759-15

15.5 cm - 6"

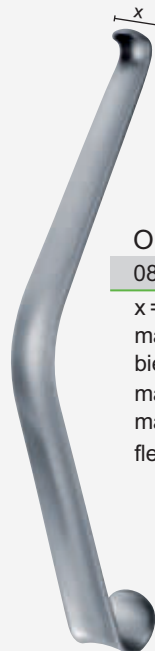

Obwegeser

08-760-16

x = 8 mm  
malleable  
biegsam  
maleable  
malléable  
flessibile

08-761-16

16 cm - 6 1/4"

x = 1 cm

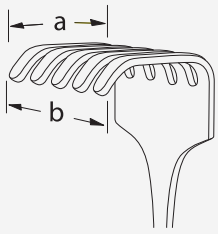

Ollier

08-762-22

a = 3.6 cm b = 3 cm  
Fig. 1



08-763-22 22.5 cm - 8 3/4"

a = 3.6 cm b = 6 cm  
Fig. 2



Kocher

08-764-21

08-765-21

5.5 cm x 1.1 cm 4 cm x 1.2 cm  
21 cm - 8 1/4" 21 cm - 8 1/4"



Langenbeck

08-766-21 21 cm - 8 1/4"

6 cm x 2 cm



Langenbeck

08-767-21 21 cm - 8 1/4"

8.5 cm x 1.5 cm

Handle vertical to the blade  
Griff vertikal zum Blatt  
Mango vertical a la hoja  
Poignée verticale à la lame  
Manico verticale verso la lama



Sauerbruch

08-768-22

4.5 cm x 1.5 cm

08-769-22

22.5 cm - 8 3/4"

7.5 cm x 2 cm

08-770-22

22 cm - 8 3/4"

6 cm x 2.3 cm

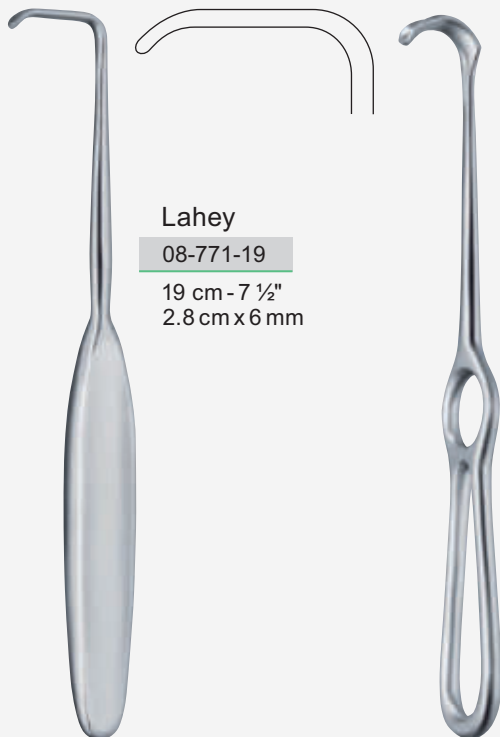

Lahey

08-771-19

19 cm - 7 1/2"  
2.8 cm x 6 mm

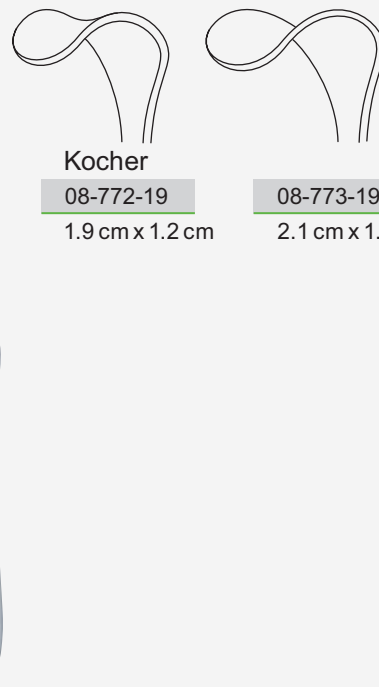

Kocher

08-772-19

1.9 cm x 1.2 cm

08-773-19

19 cm - 7 1/2"

2.1 cm x 1.4 cm

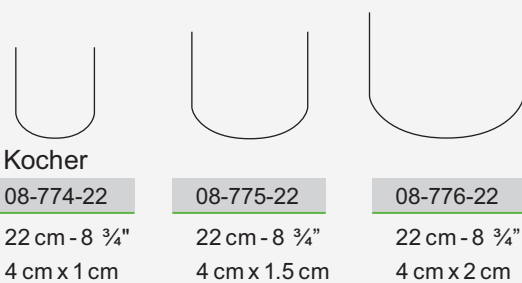

Kocher

08-774-22

22 cm - 8 3/4"  
4 cm x 1 cm

08-775-22

22 cm - 8 3/4"  
4 cm x 1.5 cm

08-776-22

22 cm - 8 3/4"  
4 cm x 2 cm





**Kocher**

08-777-23

4 cm x 1.8 cm



08-778-22 23 cm - 9"

6 cm x 2 cm



08-779-22

6 cm x 2.5 cm



08-780-22 23 cm - 9"

7.5 cm x 3 cm



08-781-22 23 cm - 9"

7.5 cm x 4 cm



**Richardson**

08-782-24

2.8 cm x 2 cm

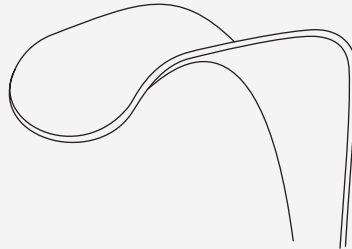

08-783-24

3.6 cm x 2.8 cm

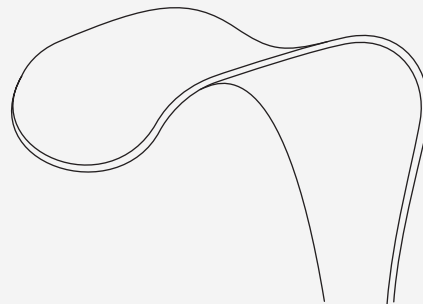

08-784-24 24 cm - 9 1/2"

4.4 cm x 3.8 cm

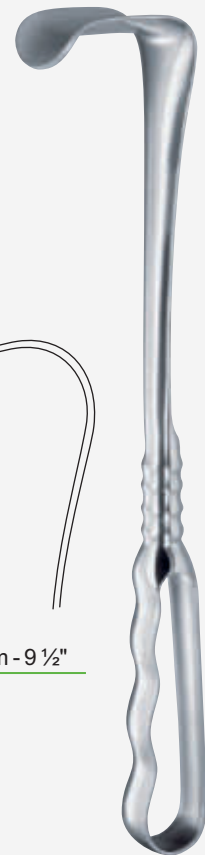



Richardson-Eastman

08-785-00

Set of 2

Satz

Juego

Jeu

Serie

08-785-28

28 cm - 11"

49 mm x 38 mm

63 mm x 49 mm

Fig.1

08-786-26

26 cm - 10 1/4"

36 mm x 28 mm

28 mm x 20 mm

Fig.2



Richardson

08-787-24

24 cm - 9 1/2"

52 mm x 22 mm



Kelly

08-788-26

26 cm - 10 1/4"

65 mm x 50 mm



Hoesel  
26 cm - 10 1/4"

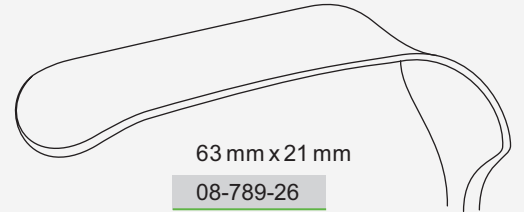

63 mm x 21 mm  
08-789-26

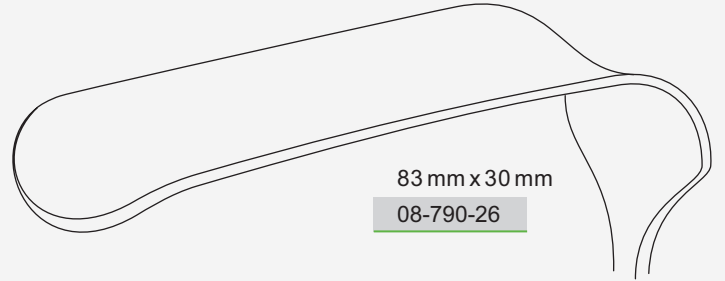

83 mm x 30 mm  
08-790-26

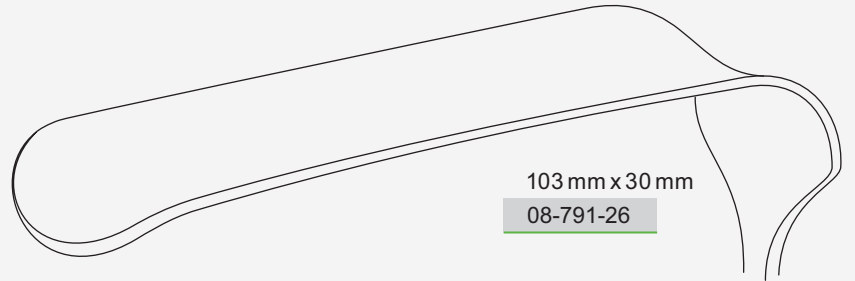

103 mm x 30 mm  
08-791-26

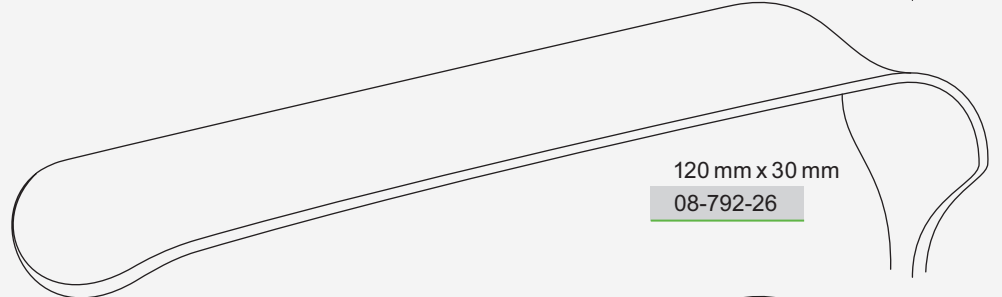

120 mm x 30 mm  
08-792-26



140 mm x 30 mm  
08-793-26

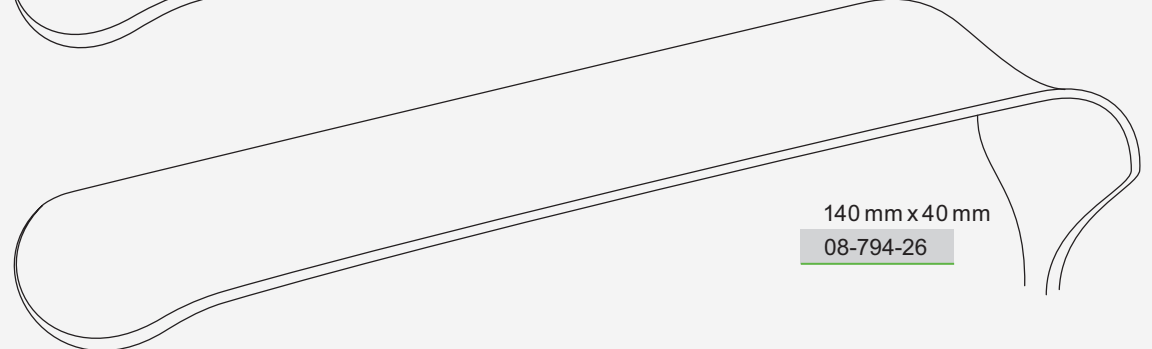

140 mm x 40 mm  
08-794-26



**Meyerding**

08-795-20

20 cm - 8"  
50 mm x 16 mm

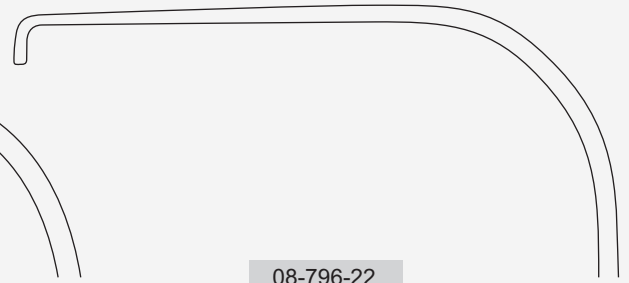
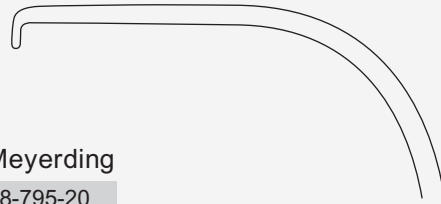

08-796-22

22 cm - 8 3/4"  
75 mm x 25 mm

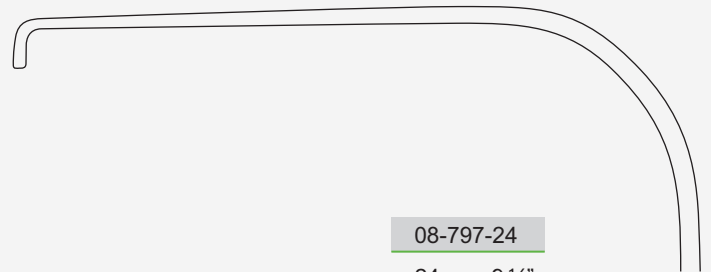

08-797-24

24 cm - 9 1/2"  
90 mm x 50 mm

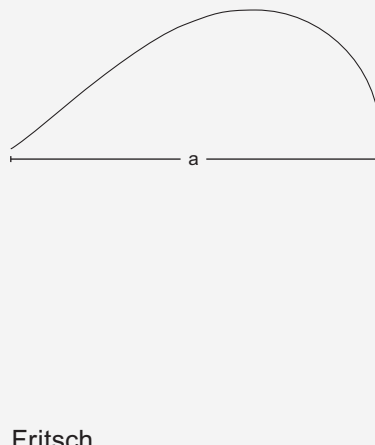

**Fritsch**

08-798-23	23.5 cm - 9 1/4"	a = 37 mm - b = 31 mm
08-798-24	24 cm - 9 1/2"	a = 38 mm - b = 40 mm
08-798-25	25 cm - 9 3/4"	a = 43 mm - b = 51 mm
08-798-25B	25 cm - 9 3/4"	a = 49 mm - b = 61 mm
08-799-25	25.5 cm - 10"	a = 48 mm - b = 75 mm
08-800-26	26.5 cm - 10 1/2"	a = 65 mm - b = 85 mm



**Simon**

08-801-28    08-802-28    28 cm - 11"  
115 mm x 22 mm    115 mm x 27 mm



**Harrington**

08-803-32    08-804-32    32 cm - 12 1/2"  
127 mm x 40 mm    127 mm x 62 mm



Mikulicz

08-805-26 26 cm - 10 1/4"  
95 mm x 35 mm

08-806-26

120 mm x 50 mm

08-807-26

150 mm x 50 mm



**Mikulicz**

08-808-26

26 cm - 10 1/4"

90 mm x 50 mm

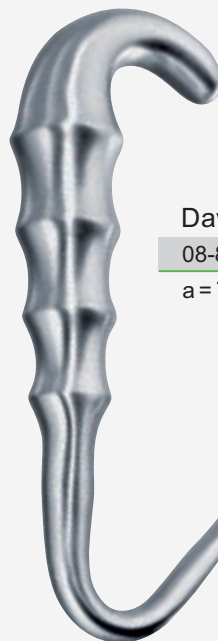

**Davidson**

08-809-16

08-810-16

16 cm - 6 1/4"

a = 75 mm - b = 50 mm

a = 75 mm - b = 90 mm





**Kelly**

08-811-27

190 mm x 38 mm

08-812-27

190 mm x 57 mm

27 cm - 10 3/4"

**Zenker**

08-813-25

25 cm - 9 3/4"

35 mm x 8 mm

08-814-26

26 cm - 10 1/4"

60 mm x 12 mm

08-815-27

27.5 cm - 10 3/4"

75 mm x 12 mm

08-816-29

29 cm - 11 1/2"

120 mm x 12 mm



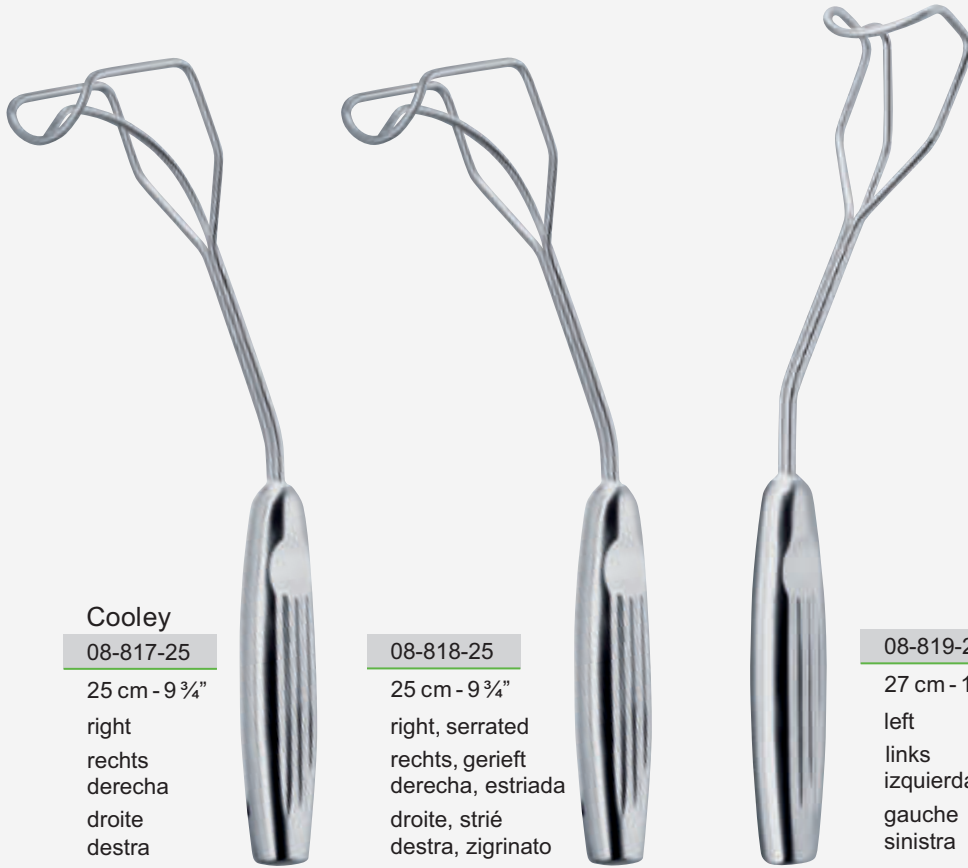

**Cooley**  
08-817-25  
25 cm - 9 3/4"  
right  
rechts  
derecha  
droite  
destra

08-818-25  
25 cm - 9 3/4"  
right, serrated  
rechts, gerieft  
derecha, estriada  
droite, strié  
destra, zigrinato

08-819-27  
27 cm - 10 1/2"  
left  
links  
izquierda  
gauche  
sinistra

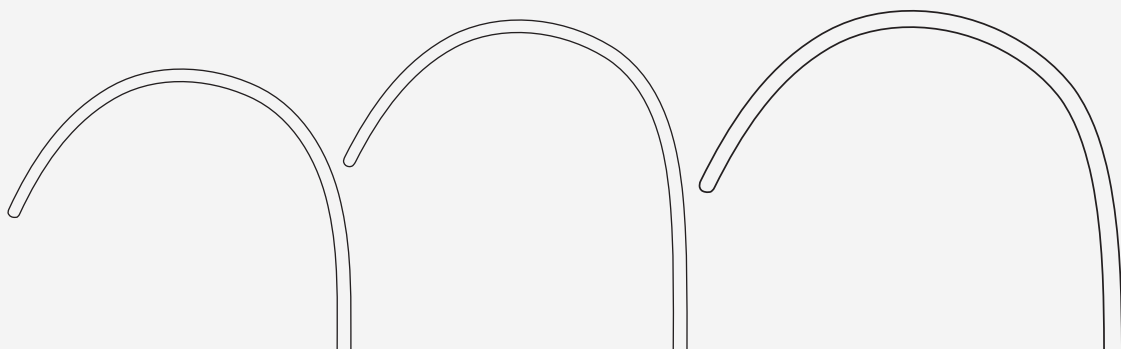

**Middeldorpf**  
08-820-25  
45 mm x 45 mm

08-821-25  
45 mm x 50 mm

08-822-25 25.5 cm - 10"  
55 mm x 70 mm

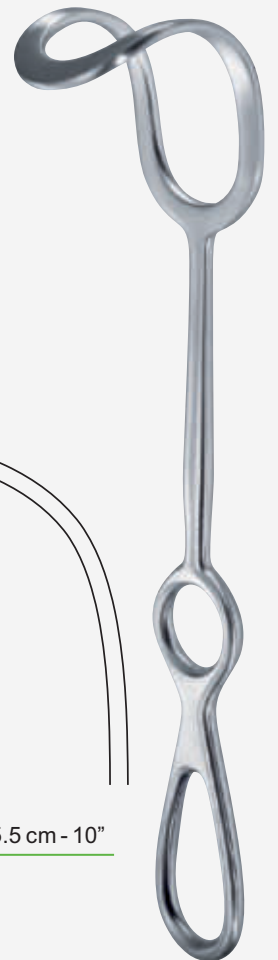



Doyen

08-823-25

25 cm - 9 3/4"

50 mm x 85 mm

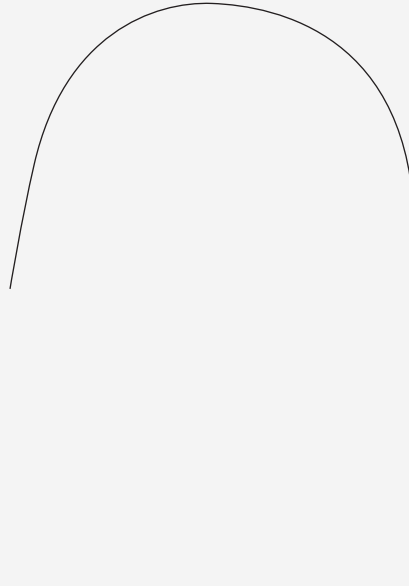

Kocher

08-825-25 80 mm x 45 mm

08-826-25 80 mm x 55 mm

08-827-25 80 mm x 65 mm

25 cm - 9 3/4"

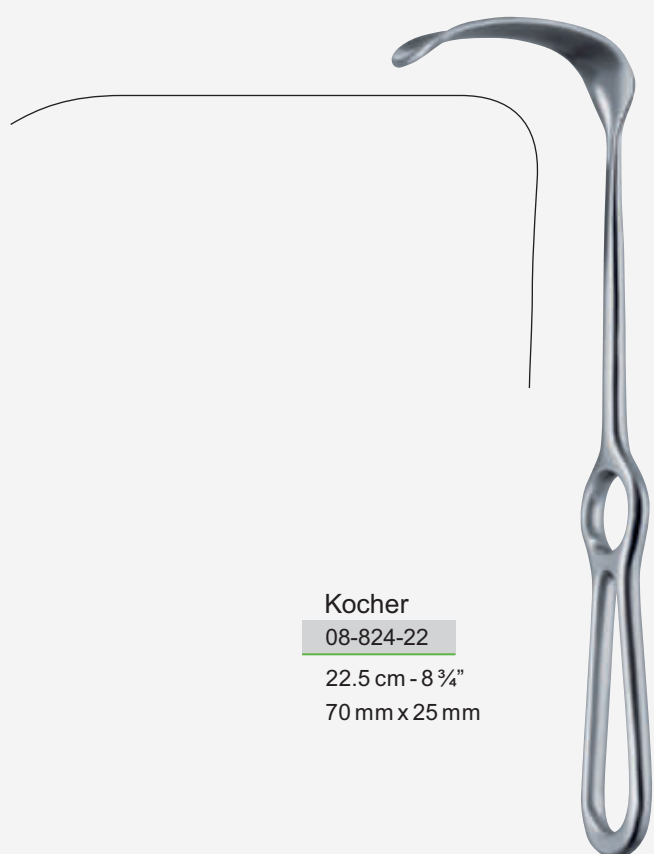

Kocher

08-824-22

22.5 cm - 8 3/4"

70 mm x 25 mm



**Tuffier**  
08-828-23  
23 cm - 9"  
64 mm x 60 mm



**Martin**  
08-829-25  
25 cm - 9 3/4"  
105 mm x 27 mm



**Sauerbruch**  
08-830-25  
25 cm - 9 3/4"  
125 mm x 37 mm

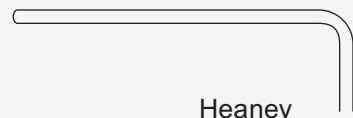

Heaney

08-831-27

45 mm x 25 mm



08-832-27 27 cm - 10 3/4"

73 mm x 28 mm



08-833-27

82 mm x 28 mm

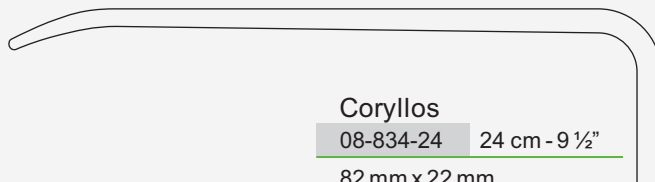

Coryllos

08-834-24 24 cm - 9 1/2"

82 mm x 22 mm



08-835-24

108 mm x 43 mm



08-836-24

115 mm x 65 mm





**Brunner**  
25 cm - 9 3/4"

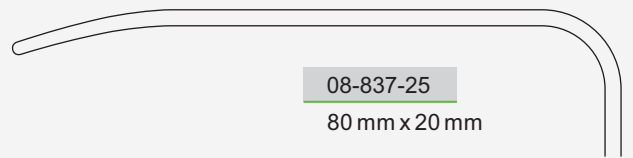

**08-837-25**  
80 mm x 20 mm

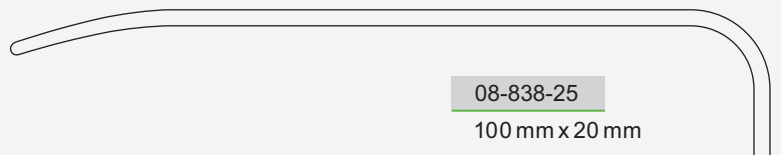

**08-838-25**  
100 mm x 20 mm



**08-839-25**  
120 mm x 25 mm



**08-840-25**  
140 mm x 25 mm



**08-841-25**  
160 mm x 30 mm



**08-842-25**  
180 mm x 30mm



**Brunner**

08-843-24

24 cm - 9 1/2"

142 mm x 25 mm



**Gil-Vernet**

08-844-24	08-845-24	08-846-24	08-847-24	08-848-24	08-849-24
x = 8 mm	x = 11 mm	x = 15 mm	x = 17 mm	x = 20 mm	x = 23 mm
24 cm - 9 1/2"	24 cm - 9 1/2"	24 cm - 9 1/2"	24 cm - 9 1/2"	24 cm - 9 1/2"	24 cm - 9 1/2"

malleable  
biegsam  
maleable  
malléable  
malleabile



**St. Marks**  
Fig. 1

08-850-29  
29 cm - 11 1/2"  
130 mm x 60 mm

**Fig. 2**

08-851-32  
32.5 cm - 12 3/4"  
180 mm x 60 mm

**Fig. 3**

08-852-33  
33 cm - 13"  
180 mm x 60 mm

Cushing  
08-853-20  
20 cm - 8"

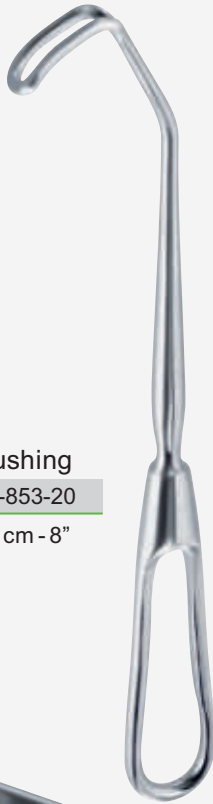

Koerte  
08-854-28  
28 cm - 11"  
120 mm x 47 mm



Morris  
08-855-21  
21 cm - 8 1/4"  
50 mm x 55 mm  
Angled



Morris  
Fig. 1

08-856-24

70 mm x 40 mm

Fig. 2

08-857-24

70 mm x 50 mm

Fig. 3

08-858-24

24.5 cm - 9 3/4"

70 mm x 65 mm





**Morris**

10-227-13	40 x 20 mm / 60 x 40 mm
10-227-15	60 x 40 mm / 80 x 60 mm
10-227-16	60 x 50 mm / 80 x 60 mm

23 cm - 9"  
Double ended



**Langenbeck**

10-221-01	22 x 6 mm
10-221-02	44 x 13 mm
10-221-03	64 x 25 mm

22 cm - 8 1/2"

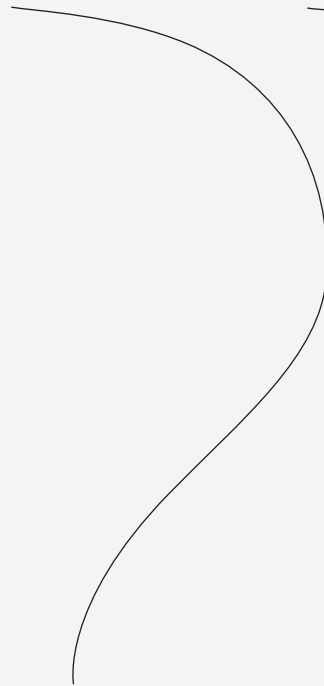

Deaver  
08-859-31  
x = 25 mm

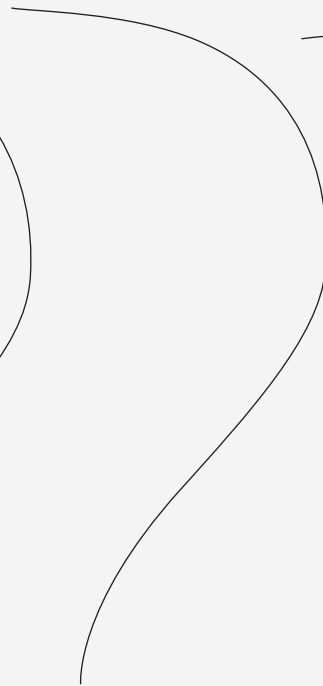

08-860-31  
x = 38 mm

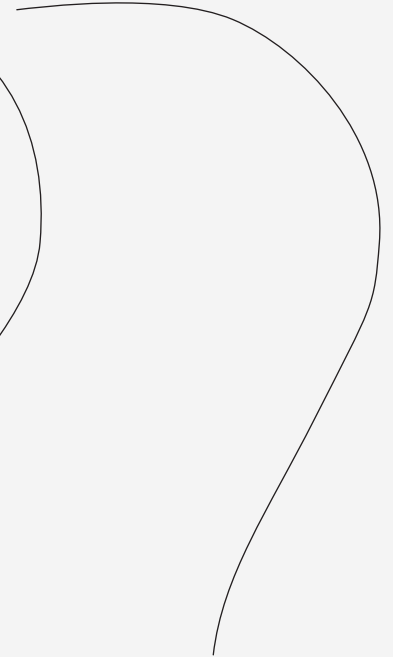

08-861-31 31.5 cm - 12 1/2"  
x = 50 mm



08-862-31  
x = 75 mm



08-863-31  
x = 100 mm



Deaver

08-864-18

18 cm - 7"

x = 19 mm

08-865-21

21.5 cm - 8 1/2"

x = 22 mm

08-866-23

23 cm - 9"

x = 25 mm



Deaver

08-867-30

30 cm - 12"

x = 25 mm

08-868-33

33 cm - 13"

x = 25 mm

08-869-36

36 cm - 14 1/4"

x = 25 mm



Deaver

08-870-30

30 cm - 12"  
x = 38 mm

08-871-30

30 cm - 12"  
x = 50 mm

08-872-30

30 cm - 12"  
x = 75 mm



**Roux**

08-873-00

Set of 3  
Satz  
Juego  
Jeu  
Serie

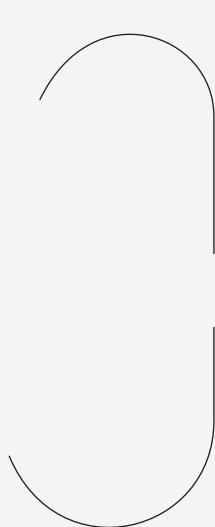

08-873-14

Fig. 1  
14 cm - 5 1/2"  
24 mm x 20 mm  
30 mm x 28 mm

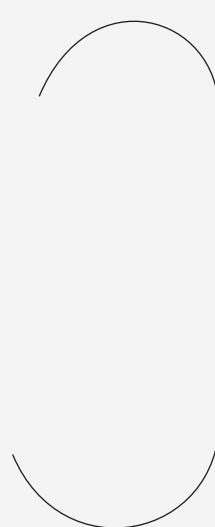

08-874-15

Fig. 2  
15 cm - 6"  
29 mm x 26 mm  
36 mm x 36 mm

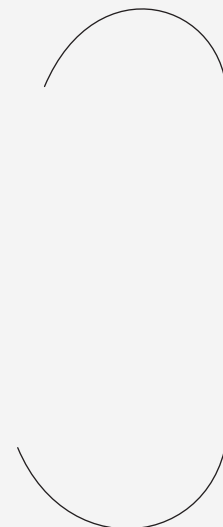

08-875-17

Fig. 3  
17 cm - 6 3/4"  
33 mm x 29 mm  
38 mm x 43 mm



**Parker**

08-876-00

Set of 2  
Satz  
Juego  
Jeu  
Serie

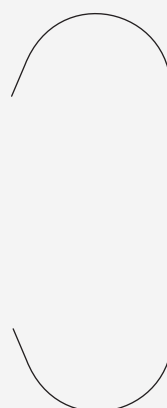

08-876-13

Fig. 1  
13.5 cm - 5 1/4"  
18 mm x 15 mm

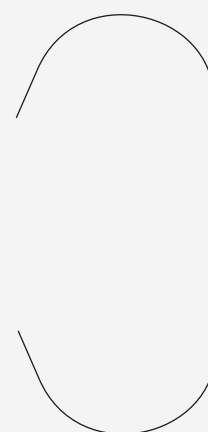

08-877-13

Fig. 2  
13.5 cm - 5 1/4"  
22 mm x 15 mm



**Parker**

08-878-00

Set of 2  
Satz  
Juego  
Jeu  
Serie

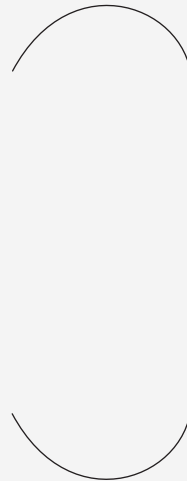

08-878-18

Fig. 1  
26 mm x 25 mm  
27 mm x 25 mm

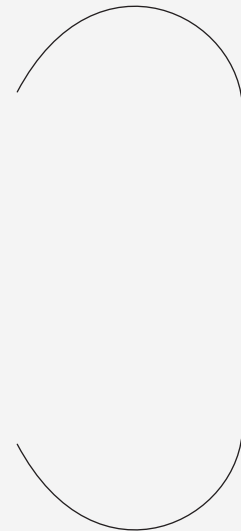

08-879-18 18 cm - 7"

Fig. 2  
29 mm x 25 mm  
27 mm x 25 mm

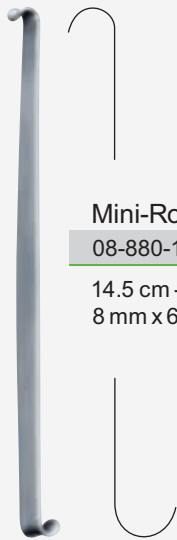

**Mini-Roux**  
08-880-14

14.5 cm - 5 3/4"  
8 mm x 6 mm

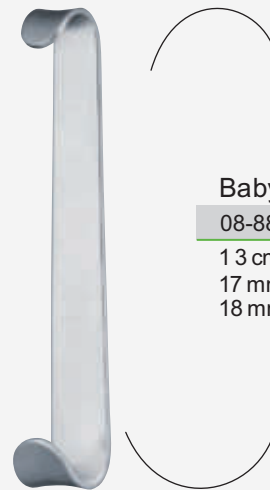

**Baby-Roux**  
08-881-13

13 cm - 5"  
17 mm x 16 mm  
18 mm x 22 mm



Mayo-Collin

08-882-00

Set of 2  
Satz  
Juego  
Jeu  
Serie

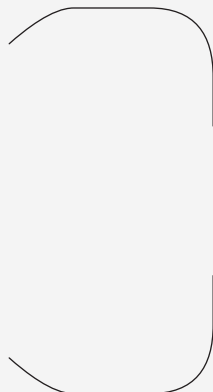

08-882-15

Fig. 1  
25 mm x 18 mm  
28 mm x 18 mm

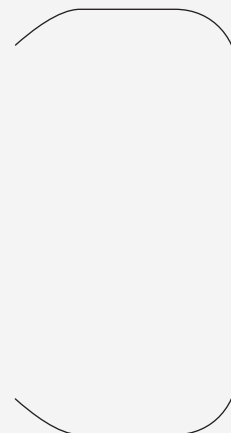

08-883-15 15 cm - 6"

Fig. 2  
28 mm x 19 mm  
32 mm x 19 mm



Parker-Langenbeck  
(US Army)

08-884-00

Set of 2  
Satz  
Juego  
Jeu  
Serie

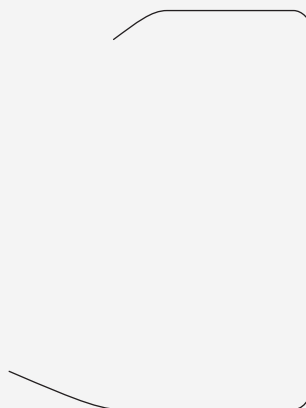

08-884-21

Fig. 1  
21 mm x 24 mm  
40 mm x 15 mm

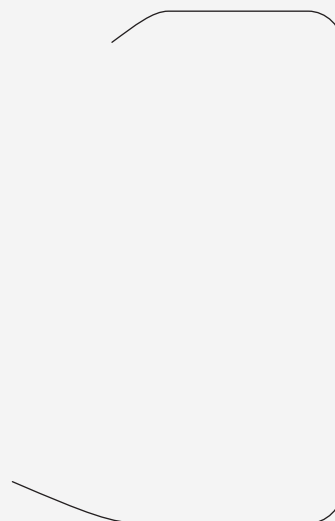

08-885-21 21 cm - 8 1/4"

Fig. 2  
25 mm x 24 mm  
45 mm x 15 mm





**Mathieu**

08-886-00

Set of 2  
Satz  
Juego  
Jeu  
Serie

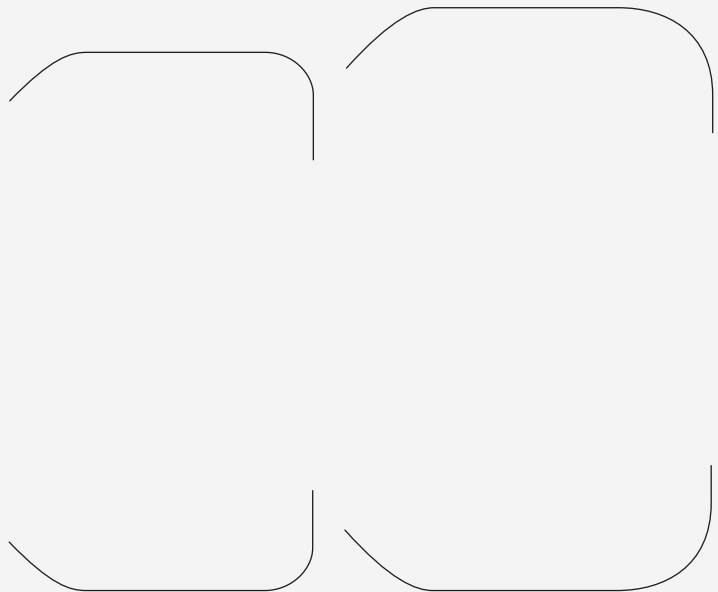

08-886-20

Fig.1  
42 mm x 13 mm  
42 mm x 26 mm

08-887-20 20 cm - 8"

Fig.2  
47 mm x 13 mm  
46 mm x 26 mm



Farabeuf  
08-888-00

Set of 2  
Satz  
Juego  
Jeu  
Serie

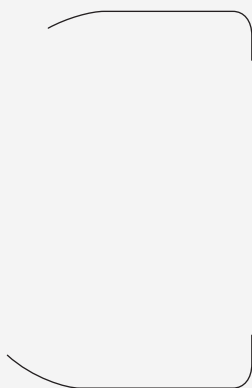

08-888-12

Fig. 1  
26 mm x 10 mm  
30 mm x 12 mm

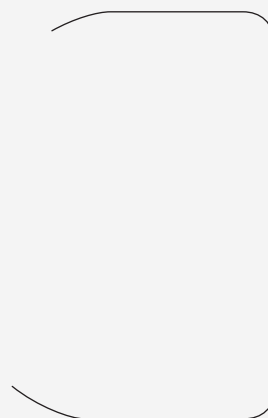

08-889-12 12 cm - 4 3/4"

Fig. 2  
30 mm x 10 mm  
34 mm x 12 mm



Farabeuf  
08-890-00

Set of 2  
Satz  
Juego  
Jeu  
Serie

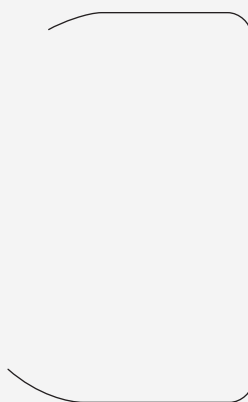

08-890-15

Fig. 1  
23 mm x 16 mm  
26 mm x 16 mm

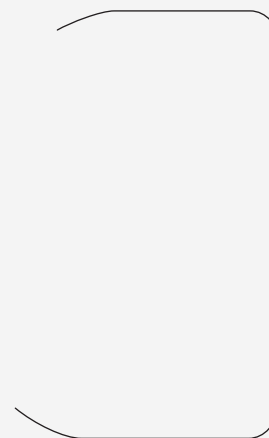

08-891-15 15 cm - 6"

Fig. 2  
27 mm x 16 mm  
30 mm x 16 mm



Alm

08-892-07

08-893-07

08-894-07

7 cm - 2 3/4"

08-892-10

08-893-10

08-894-10

10 cm - 4"

sharp  
scharf  
agudo  
pointu  
acuto

semi-sharp  
halbscharf  
semi-agudo  
semi-pointu  
semi-acuto

blunt  
stumpf  
romo  
mousse  
smusso



Holtzheimer

08-895-10

08-896-10

10 cm - 4"

sharp  
scharf  
agudo  
pointu  
acuto

blunt  
stumpf  
romo  
mousse  
smusso



Bose

08-897-07

7 cm - 2 3/4"



Jansen

08-898-10

08-899-10

10 cm - 4"

08-898-11

08-899-11

11 cm - 4 1/4"

sharp  
scharf  
agudo  
pointu  
acuto

blunt  
stumpf  
romo  
mousse  
smusso



Cloward-Contour

08-900-14      08-901-14      14 cm - 5½"

3x4	3x4
sharp	blunt
scharf	stumpf
agudo	romo
pointu	mousse
acuto	smusso



Wullstein

08-902-10      08-903-10      10 cm - 4"

3x3	3x3
sharp	blunt
scharf	stumpf
agudo	romo
pointu	mousse
acuto	smusso



Weitlaner-Wullstein

08-904-13      08-905-13      13 cm - 5"

3x3	3x3
sharp	blunt
scharf	stumpf
agudo	romo
pointu	mousse
acuto	smusso



Milligan

08-906-13      13 cm - 5"

3x3
blunt
stumpf
romo
mousse
smusso



**Belucci**  
08-907-11  
08-907-13

1x2  
left, blunt  
links, stumpf  
izquierda, romo  
gauche, mousse  
sinistra, smusso



**Belucci**  
08-908-11 11 cm - 4 1/4"  
08-908-13 13 cm - 5"

1x2  
right, blunt  
rechts, stumpf  
derecha, romo  
droit, mousse  
destra, smusso



**Mollison**  
08-909-15

15 cm - 6"  
4x4  
sharp  
scharf  
agudo  
pointu  
acuto

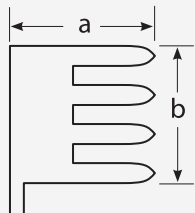

**Weitlaner-Loktite**

08-910-10	08-911-10	08-912-10	08-913-10	08-914-10	08-915-10	10.5 cm - 4 1/4"	a = 17 mm- b = 13 mm
08-910-13	08-911-13	08-912-13	08-913-13	08-914-13	08-915-13	13 cm - 5"	a = 17 mm- b = 17 mm
08-910-16	08-911-16	08-912-16	08-913-16	08-914-16	08-915-16	16.5 cm - 6 1/2"	a = 17 mm- b = 17 mm
08-910-20	08-911-20	08-912-20	08-913-20	08-914-20	08-915-20	20 cm - 8"	a = 20 mm- b = 19 mm
08-910-26	08-911-26	08-912-26	08-913-26	08-914-26	08-915-26	26 cm - 10 1/4"	a = 26 mm- b = 21 mm
2 x 3 sharp scharf agudo pointu acuto	2 x 3 semi-sharp halbscharf semi-agudo semi-pointu semi-acuto	2 x 3 blunt stumpf romo mousse smusso	3 x 4 sharp scharf agudo pointu acuto	3 x 4 semi-sharp halbscharf semi-agudo semi-pointu semi-acuto	3 x 4 blunt stumpf romo mousse smusso		



Plester

08-916-13

08-917-13

13 cm - 5"

2x2  
blunt  
stumpf  
romo  
mousse  
smusso

2x2  
sharp  
scharf  
agudo  
pointu  
acuto



Plester

08-918-11

2x1  
left, blunt  
links, stumpf  
izquierda, romo  
gauche, mousse  
sinistra, smusso



08-919-11

11 cm - 4 1/4"

1x2  
right, blunt  
rechts, stumpf  
derecha, romo  
droit, mousse  
destra, smusso

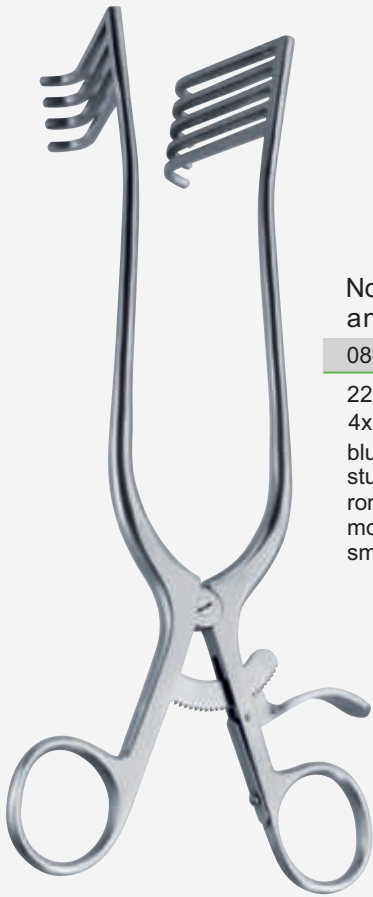

Norfolk  
and Norwich

08-920-22

22 cm - 8 3/4"

4x5

blunt  
stumpf  
romo  
mousse  
smusso



Travers

08-921-21

21.5 cm - 8 1/2"

4x5

blunt  
stumpf  
romo  
mousse  
smusso



Anderson-Adson

08-922-19

4x4  
sharp  
scharf  
agudo  
pointu  
acuto

08-923-19

4x4  
blunt  
stumpf  
romo  
mousse  
smusso

19.5 cm - 7 3/4"

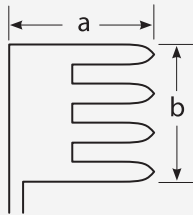

Adson (Cone)

08-924-13	08-925-13	13 cm - 5"	a = 17 mm- b = 19 mm
08-924-16	08-925-16	16 cm - 6 ¼"	a = 17 mm- b = 19 mm
08-924-20	08-925-20	20 cm - 8"	a = 20 mm- b = 20 mm
08-924-26	08-925-26	26 cm - 10 ¼"	a = 26 mm- b = 21 mm

3x4  
sharp  
scharf  
agudo  
pointu  
acuto

3x4  
blunt  
stumpf  
romo  
mousse  
smusso

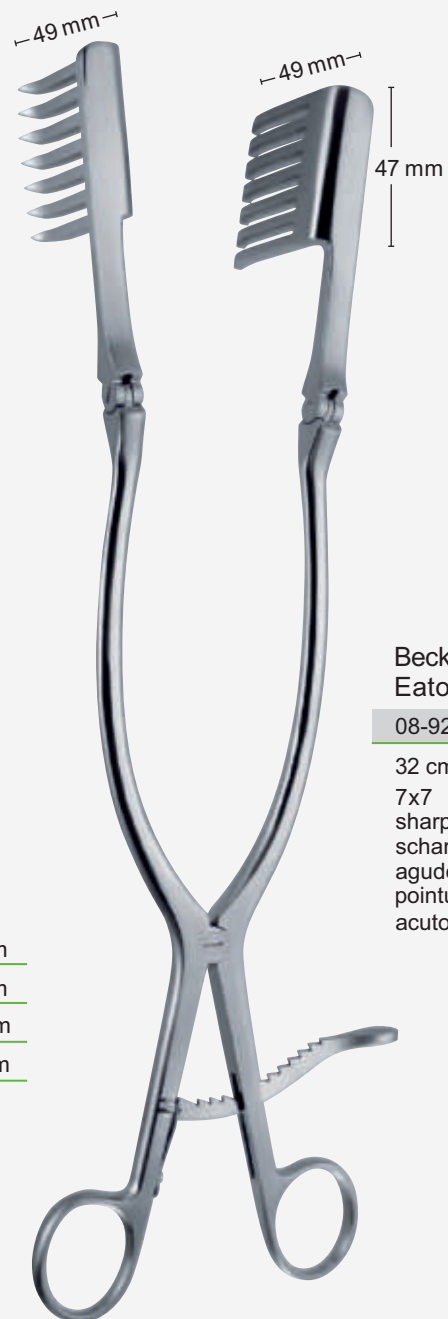

Beckmann-Eaton

08-926-32

32 cm - 12 ½"  
7x7  
sharp  
scharf  
agudo  
pointu  
acuto





**Beckmann**

08-927-31	08-928-31	08-929-31	31 cm - 12 1/4"
4x4 sharp scharf agudo pointu acuto	4x4 semi-sharp halbscharf semi-agudo semi-pointu semi-acuto	4x4 blunt stumpf romo mousse smusso	

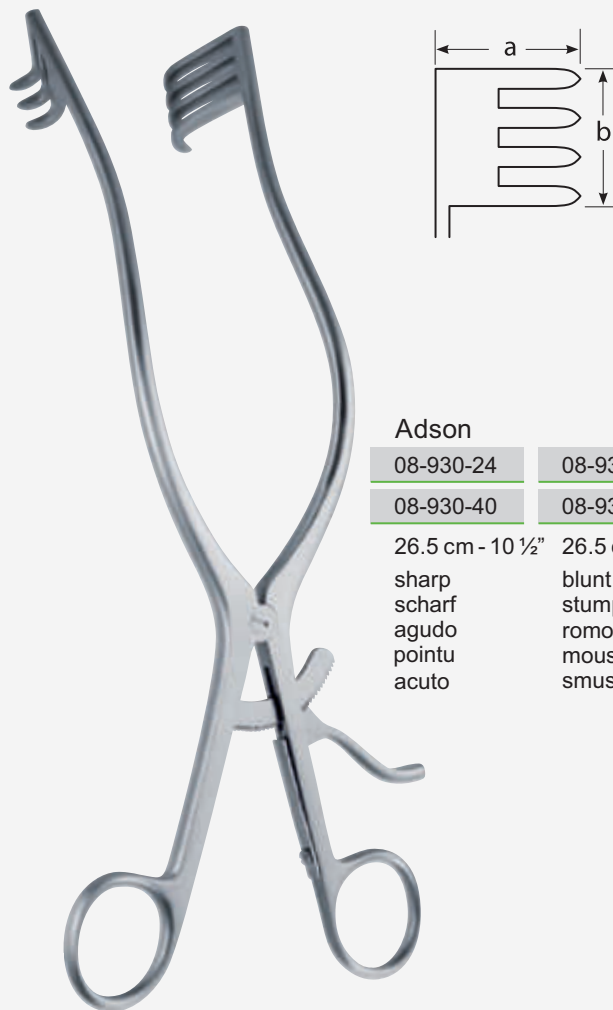

**Adson**

08-930-24	08-931-24	3x4	a = 24 mm - b = 24 mm
08-930-40	08-931-40	6x6	a = 40 mm - b = 40 mm
26.5 cm - 10 1/2"	26.5 cm - 10 1/2"		
sharp scharf agudo pointu acuto	blunt stumpf romo mousse smusso		

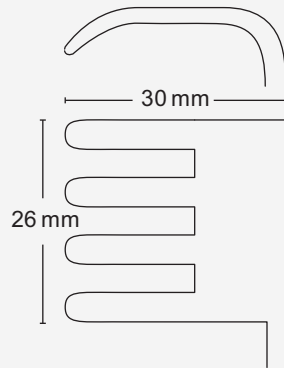

Beckmann-Adson

08-932-31

blunt  
stumpf  
romo  
mousse  
smusso

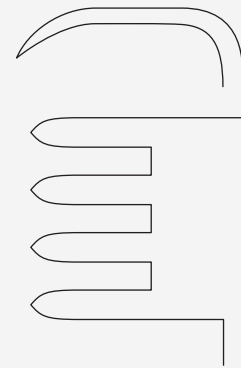

08-933-31 31 cm - 12 1/4"

sharp  
scharf  
agudo  
pointu  
acuto

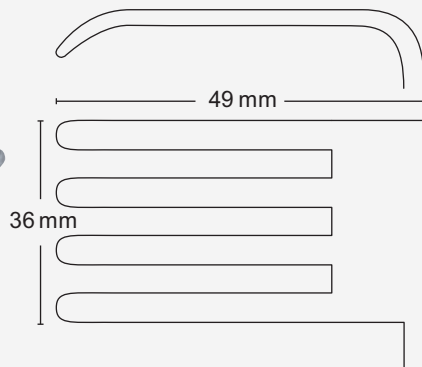

08-934-31

blunt, with deep blades  
stumpf, mit tiefen Blättern  
romo, con palas profundas  
mousse, avec lames profondes  
smusso, con valve profonde

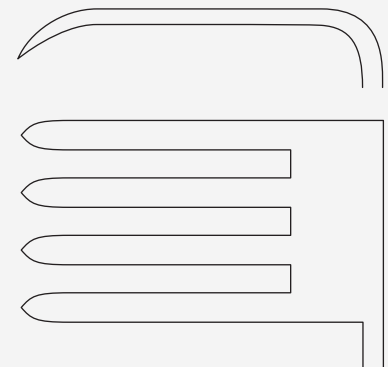

08-935-31

sharp, with deep blades  
scharf, mit tiefen Blättern  
agudo, con palas profundas  
pointu, avec lames profondes  
acuto, con valve profonde



Gelpi-Loktite

08-936-09
08-936-11
08-936-13
08-936-15
08-936-18



08-937-09	9 cm - 3 1/2"
08-937-11	11 cm - 4 1/4"
08-937-13	13 cm - 5"
08-937-15	15 cm - 6"
08-937-18	18 cm - 7"



Markham-Meyering

08-938-18	08-939-18	18 cm - 7"
right	left	
rechts	links	
derecha	izquierda	
droit	gauche	
destra	sinistra	



Rigby

08-940-18
18 cm - 7"



**Cloward**

08-941-18	18 mm
08-941-20	20 mm
08-941-23	23 mm

16 cm - 6 1/4"



**Tittle**

08-942-20
-----------

20 cm - 8"  
 12 x 14 mm



Hibbs  
08-943-00  
Set of two  
24.5 cm - 9 3/4"

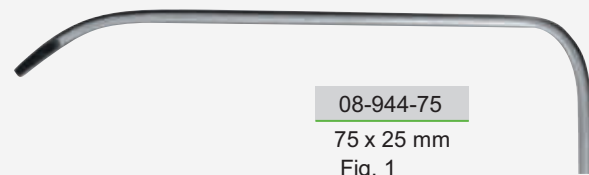

08-944-75  
75 x 25 mm  
Fig. 1

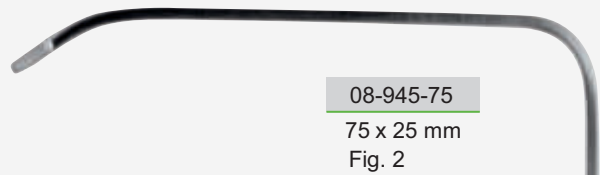

08-945-75  
75 x 25 mm  
Fig. 2

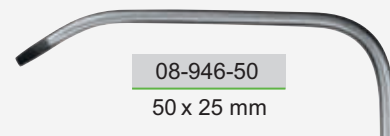

08-946-50  
50 x 25 mm



08-947-10  
100 x 25 mm



Meyerding

08-948-32	32 x 25 mm
08-948-54	54 x 25 mm
08-948-60	60 x 25 mm

24.5 cm - 9 3/4" blade size



Markham-Meyerding

08-949-19
-----------

19 cm - 7 1/2"  
 Left blade



Markham-Meyerding

08-950-19	50 x 26 mm
-----------	------------

19 cm - 7 1/2"  
 Right blade

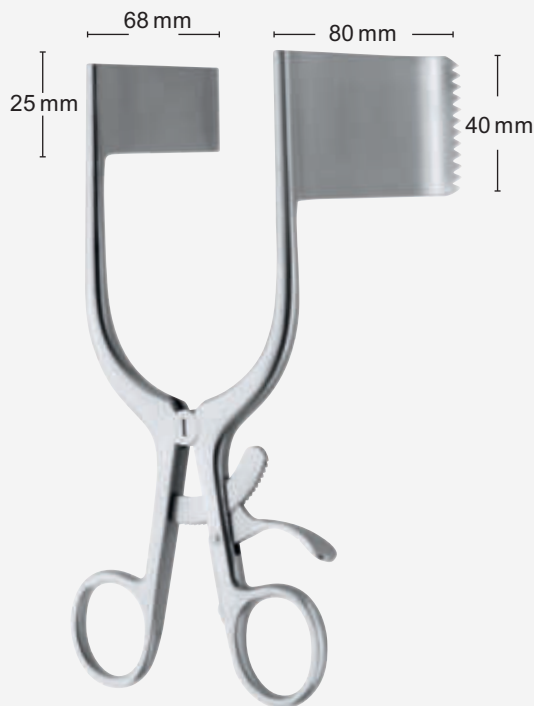

Darling

08-951-18

18 cm - 7"

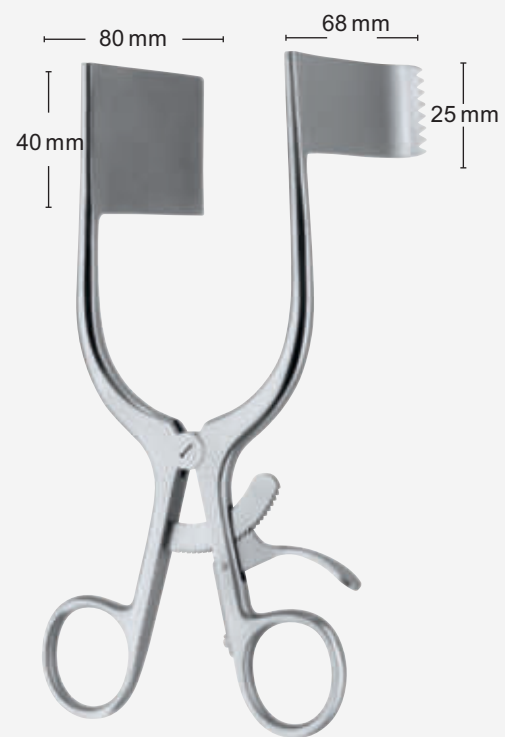

Darling

08-952-18

18 cm - 7"



**Henley**

08-993-00	Complete set consisting of:
08-993-16	Retractor 3x4 teeth 16.5 cm - 6½" Sharp
08-995-19	Fig. 1 Central blade 19x16 mm
08-996-25	Fig. 2 Central blade 25x16 mm
08-997-32	Fig. 3 Central blade 32x16 mm
08-994-00	Complete set consisting of:
08-994-16	Retractor 3x4 teeth 16.5 cm - 6½" Blunt
08-995-19	Fig. 1 Central blade 19x16 mm
08-996-25	Fig. 2 Central blade 25x16 mm
08-997-32	Fig. 3 Central blade 32x16 mm



Fig. 1  
08-995-19

19 mm x 16 mm



Fig. 2  
08-996-25

25 mm x 16 mm



Fig. 3  
08-997-32

32 mm x 16 mm





**Baby Collin**

08-998-00	Complete set consisting of:	
08-998-18	1 Retractor	18 cm - 7"
08-998-01	1 pair of blade	40x18 mm
08-998-02	1 pair of blade	40x27 mm



**Collin**

08-999-22	22 cm - 8¾"	x = 100 mm
-----------	-------------	------------

**Collin**

08-101-22	Complete set consisting of:	
	Retractor	22.5 cm - 8¾"
	1 pair of lateral blade	a=38 mm b=60mm
	1 center blade	a=38 mm b=55mm
08-102-22	Complete set consisting of:	
	Retractor	22.5 cm - 8¾"
	1 pair of lateral blade	a=38 mm b=80mm
	1 center blade	a=50 mm b=75mm
08-103-22	Complete set consisting of:	
	Retractor	22.5 cm - 8¾"
	1 pair of lateral blade	a=37 mm b=98mm
	1 center blade	a=53 mm b=76mm

x = 100 mm





**Collin**

08-104-26	Complete set consisting of:
	1 Retractor 26 cm - 10¼"
	1 pair of lateral blade a=60 mm b=80mm
	1 center blade a=60 mm b=75mm

x = 100 mm

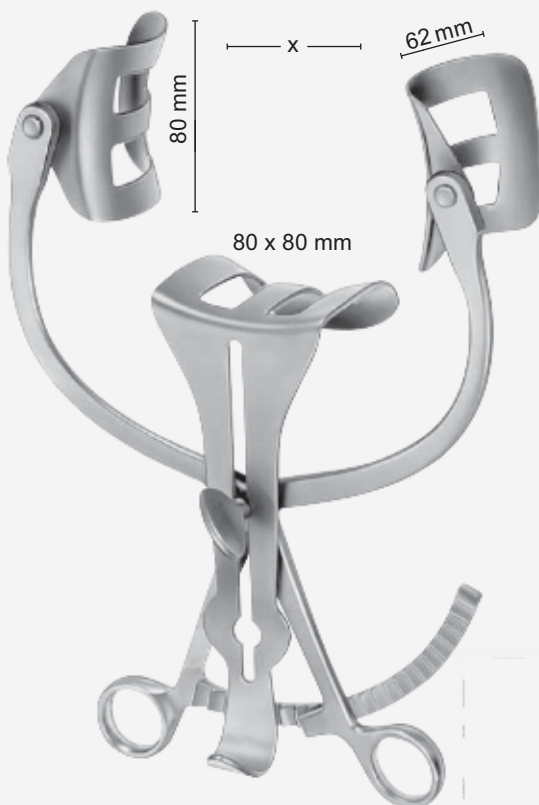

**Holzbach**

08-105-26	Complete set consisting of:
	1 Retractor 26 cm - 10¼"
	1 pair of lateral blade a=62 mm b=80mm
	1 center blade a=80 mm b=80mm

x = 100 mm

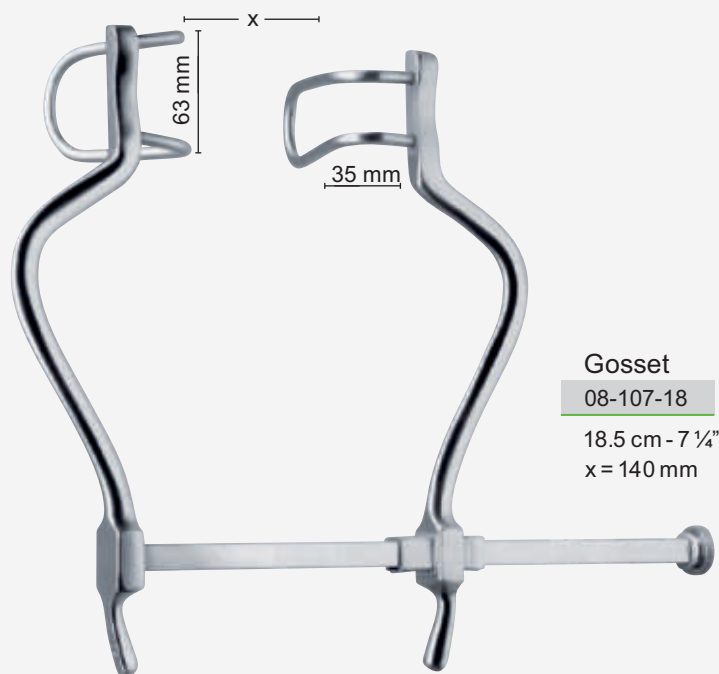
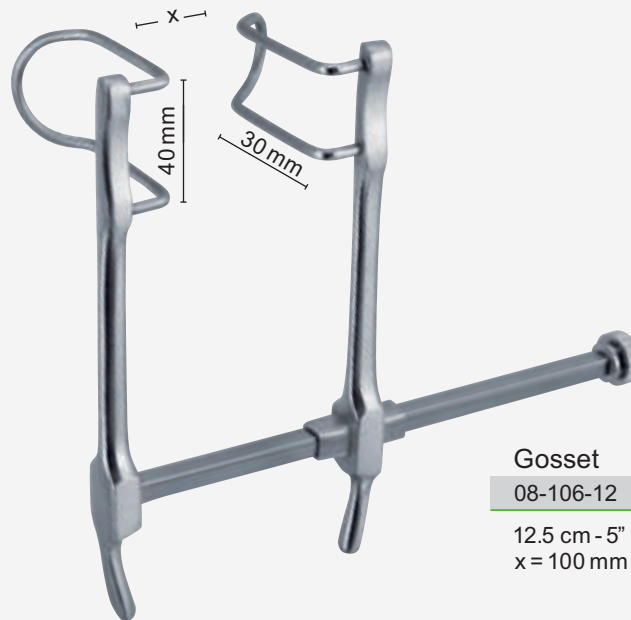



**Gosset**

08-108-16 Complete set consisting of:

08-108-00	Retractor
08-108-01	Lateral blade 35x63mm
08-108-02	Center blade 65x70mm

x = 160 mm



**Balfour**

08-109-20 Complete set consisting of:

08-109-00	Retractor
08-109-01	Lateral blade 35x100mm
08-109-02	Center blade 70x100mm

x = 200 mm



**Balfour - Baby**

08-110-27 Complete set consisting of:

08-110-00	Retractor
08-110-01	Lateral blade 27x27mm
08-110-02	Center blade 20x24mm

x = 90 mm



#### Balfour

08-111-18 Complete set consisting of:

08-111-00 Retractor

08-111-01 Lateral blade 35x70mm

08-111-02 Center blade 45x80mm

x = 180 mm

08-112-18 Complete set consisting of:

08-112-00 Retractor

08-112-01 Lateral blade 35x100mm

08-112-02 Center blade 70x85mm

x = 250 mm

08-113-45 45 mm x 80 mm

08-113-70 70 mm x 85 mm

08-113-80 80 mm x 90 mm

Center blades only  
Mittelvalven allein  
Valvas centrales sola  
Valves centrales seul  
Valve centrali solo



Ricard - 1

08-114-28	Complete set consisting of:
08-114-00	Retractor
08-114-01	Lateral blade 60x80mm
08-114-02	Center blade 55x70mm

x = 280 mm



O'Sullivan-O'Connor

08-115-45	Complete set consisting of:
08-115-00	Retractor
08-115-01	Lateral blade 60x80mm
08-115-02	Center blade 55x70mm

Ricard - 2

08-115-30	Complete set consisting of:
08-116-00	Retractor
08-116-01	Lateral blade 70x85mm
08-116-02	Center blade 80x90mm

x = 300 mm



O'Sullivan-O'Connor - Baby

08-130-00	Complete set consisting of:
	1 Frame
08-156-01	Fig. 1 1 blade 45x17cm
08-157-02	Fig. 2 1 blade 90x37cm
08-158-03	Fig. 3 1 blade 90x45cm



Fig. 1  
08-156-01  
45 mm x 17 mm

Fig. 2  
08-157-02  
90 mm x 37 mm

Fig. 3  
08-158-03  
90 mm x 45 mm



Friedmann  
08-159-10  
10 cm - 4"



**Kirschner, oval**

08-117-00	Complete set consisting of:
08-117-24	1 Frame 24x30cm
08-118-05	3 blades 5x6.5cm
08-119-08	1 blade 8x9cm
08-120-05	1 blades 5x9.8cm
08-121-03	1 blade 3.5x10.5cm

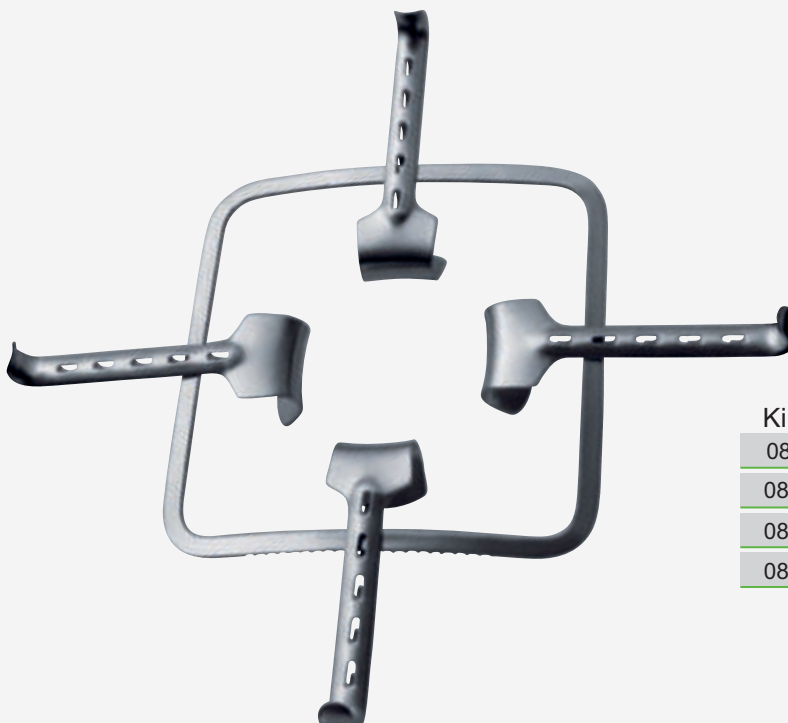

**Kirschner**

08-122-00	Complete set consisting of:
08-122-24	1 Frame 24x24cm
08-123-04	2 blades 4x5.5cm
08-124-50	2 blade 5x6.5cm



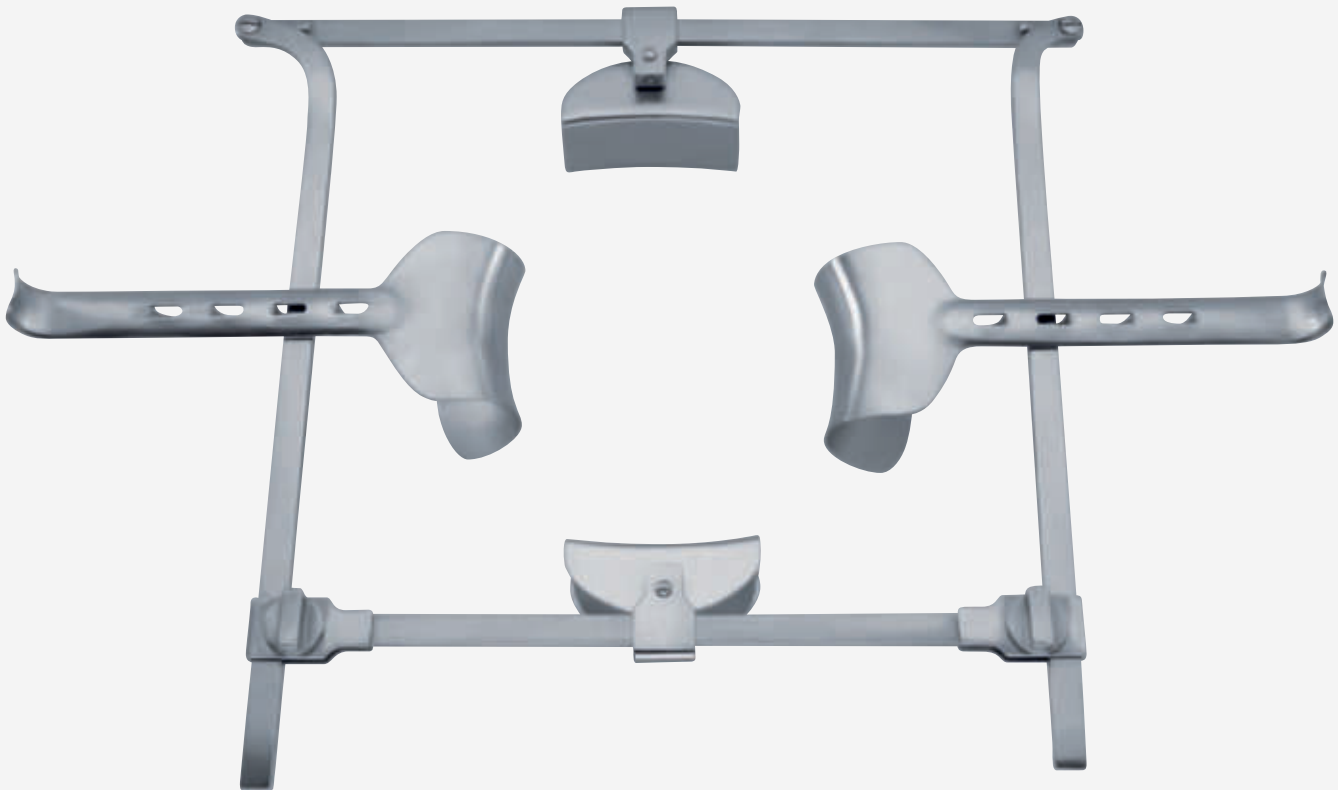

**Franz**

08-130-00	Complete set consisting of:
08-130-06	1 Frame 30x30cm
08-131-04	2 blades 4x6cm
08-132-04	2 blade 4.5x8cm
08-134-05	2 blades 5x6.5cm
08-135-06	2 blade 6x8.5cm

**Franz**

08-130-01	Complete set consisting of:
08-130-06	1 Frame 30x30cm
08-131-04	2 blades 4x6cm
08-134-05	2 blade 5x6.5cm
08-135-06	2 blade 6x8.5cm

Abdominal retractors  
 Bauchdeckenhalter  
 Separadores abdominales  
 Ecarteurs abdominaux  
 Divaricatori addominali



Franz

08-125-30

Frame 30x30cm



08-131-04

4 cm x 6 cm



08-132-04

4.5 cm x 8 cm



08-133-04

4 cm x 5.5 cm



08-134-05

5 cm x 6.5 cm



08-135-06

6 cm x 8.5 cm



08-136-08

8 cm x 9 cm



08-137-05

5 cm x 9.8 cm



08-138-03

3.5 cm x 10.5 cm



**Emma**

08-139-33	08-140-33	08-141-33	33 cm - 13"
-----------	-----------	-----------	-------------

30 mm	40 mm	50 mm
-------	-------	-------

malleable  
biegsam  
malléable  
maleable  
flessibile

**Martin**

08-142-20	08-143-20	08-144-25
-----------	-----------	-----------

20 cm - 8"	20 cm - 8"	25 cm - 9 3/4"
12 mm	17 mm	25 mm

soft  
weich  
flexible  
souple  
morbido

**Haberer Modified**

08-145-20	08-146-20	08-147-20	08-148-20	08-149-20	08-150-20	20 cm - 8"
-----------	-----------	-----------	-----------	-----------	-----------	------------

6,5 mm	9,5 mm	13 mm	16 mm	19 mm	25 mm
--------	--------	-------	-------	-------	-------

malleable, very soft  
biegsam, sehr weich  
maleable, muy flexible  
malléable, très souple  
flessibile, molto morbido



Abdominal spatulas  
Bauchspatel  
Espátulas abdominales  
Spatulas abdominales  
Spatole addominali

comed  
operate better with us



Haberer

08-151-20

20 cm - 8"

17 mm / 25 mm

08-152-28

28 cm - 11"

25 mm / 30 mm

08-153-30

30 cm - 12"

37 mm / 45 mm

malleable  
biegsam  
maleable  
malléable  
flessibile



Reverdin

08-154-28

28 cm - 11"

46 mm x 60 mm



Cloward  
Fig. 1

13-873-15	Retractor only	15 cm - 6"
13-873-00	Complete set consisting of:	
13-873-15	1 Retractor	
	1 pair of blades 13-877-40 to 13-877-60	



Cloward  
Fig. 2

13-874-17	Retractor only	17 cm - 6 3/4"
12-874-00	Complete set consisting of:	
13-874-17	1 Retractor	
	1 pair of blades 13-877-40 to 13-877-60	



Cloward  
Fig. 3

13-875-15	Retractor only	25 cm - 10"
13-875-00	Complete set consisting of:	
13-875-15	1 Retractor	
	1 pair of blades 13-876-40 to 13-876-60	

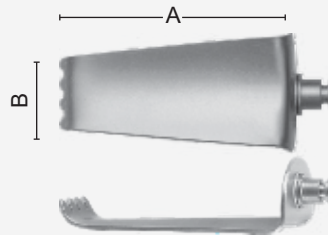

	A	B
13-876-40	40 x 16 mm	
13-876-45	45 x 16 mm	
13-876-50	50 x 16 mm	
13-876-55	55 x 16 mm	
13-876-60	60 x 16 mm	

Toothed blade

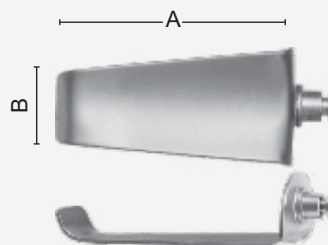

	A	B
13-877-40	40 x 16 mm	
13-877-45	45 x 16 mm	
13-877-50	50 x 16 mm	
13-877-55	55 x 16 mm	
13-877-60	60 x 16 mm	

Non toothed blade

Laminectomy retractors  
Laminektomiesperrer  
Separadores para laminectomia  
Ecarteurs pour laminectomie  
divaricatori per laminectomia

comed  
operate better with us



Inge

08-166-16

16.5 cm - 6 1/2"

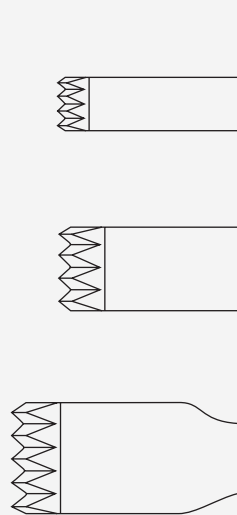

Inge

08-167-16

16 cm - 6 1/4"

08-167-25

25 cm - 10"

08-167-27

27 cm - 10 1/2"

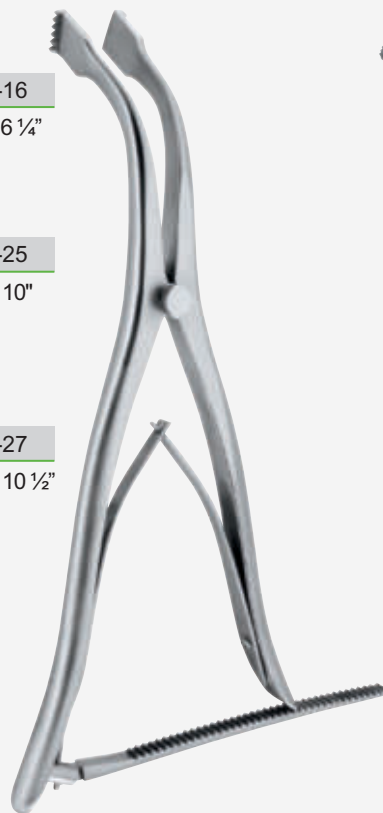

Cloward-  
Vertebra

08-168-16

16 cm - 6 1/4"



**Inge**

08-171-12	12 mm
08-171-08	8 mm
27 cm - 10 1/2"	

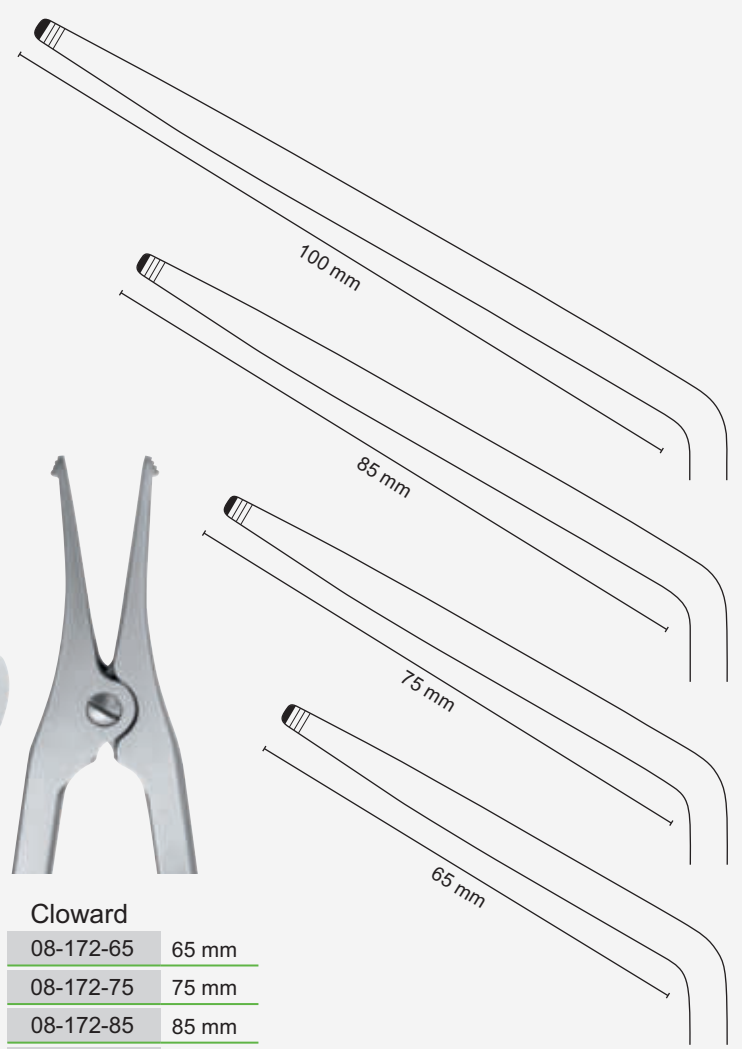

**Cloward**

08-172-65	65 mm
08-172-75	75 mm
08-172-85	85 mm
08-172-10	100 mm



08-217-07 7 cm - 2 ¾"  
1 prongs Length of blades



08-218-08 8 cm - 3 ¼"  
08-219-10 10 cm - 4"  
3 prongs Length of blades





Suture  
Naht  
Sutura  
Suture  
Sutura

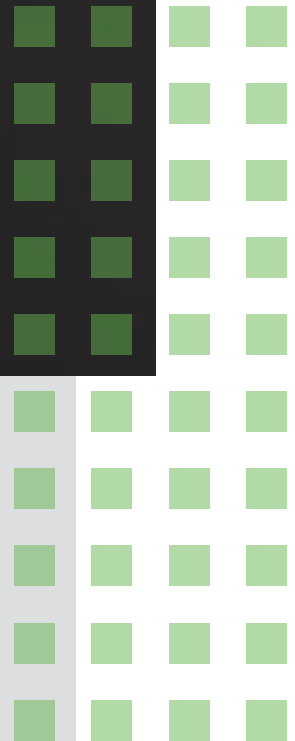



Crile-Murray

09-800-13 13 cm - 5¼"

09-800-15 15 cm - 6"



Crile-Wood

09-801-15 15 cm - 6"

09-801-18 18 cm - 7"



Hegar-Baumgartner

09-802-14

14 cm - 5 ¾"



Brown

09-803-13 13 cm - 5"

09-803-18 18mc - 7"



Collier

09-804-12

12.5 cm - 5"

heavy pattern, diagonal serrated jaw  
 kräftiges Modell, Maul diagonal gerieft  
 modelo fuerte, boca estriada diagonalmente  
 modèle fort, mors strié diagonalement  
 modello forte, morso con striae diagonali



Derf

09-805-12

12.5 cm - 5"



09-806-12

12 cm - 4 ¾"



**Webster**

09-807-13

13 cm - 5"  
smooth  
glatt  
liso  
lisse  
liscio



**Halsey**

09-808-13

smooth  
glatt  
liso  
lisse  
liscio



09-809-13

serrated  
gerieft  
estriada  
strié  
zigrinato

13 cm - 5"

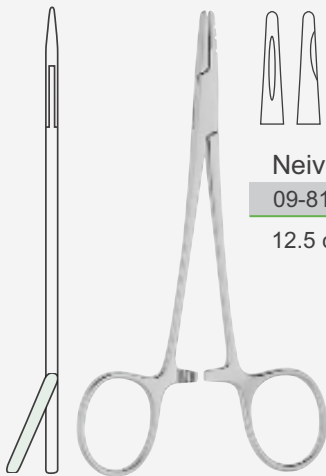

**Neivert**

09-810-12

12.5 cm - 5"

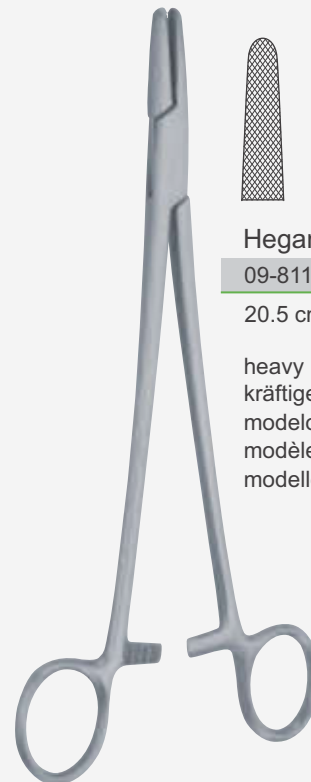

**Hegar**

09-811-20

20.5 cm - 8"

heavy pattern  
kräftiges Modell  
modelo fuerte  
modèle fort  
modello forte

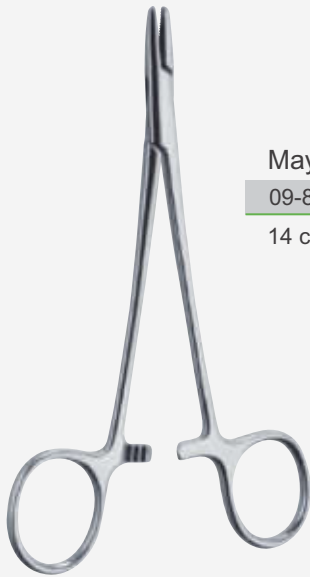

Mayo-Hegar

09-812-14	09-813-16	09-814-18	09-815-20	09-816-24	09-817-26	09-818-30
14 cm - 5 1/2"	16 cm - 6 1/4"	18 cm - 7"	20 cm - 8"	24 cm - 9 1/2"	26 cm - 10 1/4"	30 cm - 12"

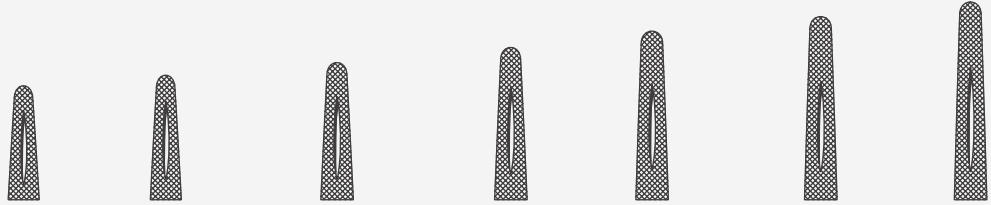

09-819-14	09-820-16	09-821-18	09-822-20	09-823-24	09-824-26
14 cm - 5 1/2"	16 cm - 6 1/4"	18 cm - 7"	20 cm - 8"	24 cm - 9 1/2"	26 cm - 10 1/4"

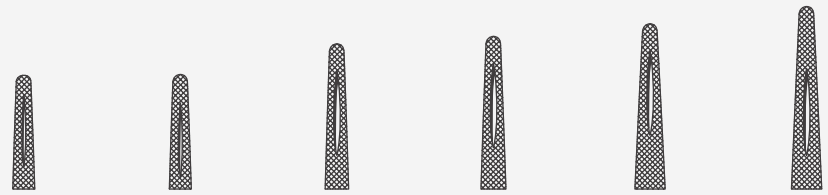

delicate pattern  
schlankes Modell  
modelo delicado  
motif délicat  
modello delicato



Heaney

09-825-16	16 cm - 6 1/4"
09-825-18	18 cm - 7"
09-825-20	20 cm - 8"



Sarot

09-826-18	18 cm - 7"
09-826-26	26 cm - 10 1/4"



Jameson

09-827-23	23.5 cm - 9 1/4"
-----------	------------------





Masson

09-828-27

27 cm - 10 3/4"



Finochietto

09-829-27

27 cm - 10 3/4"



Stratte

09-830-23

23 cm - 9"



Wangensteen

09-831-27

27 cm - 10 3/4"

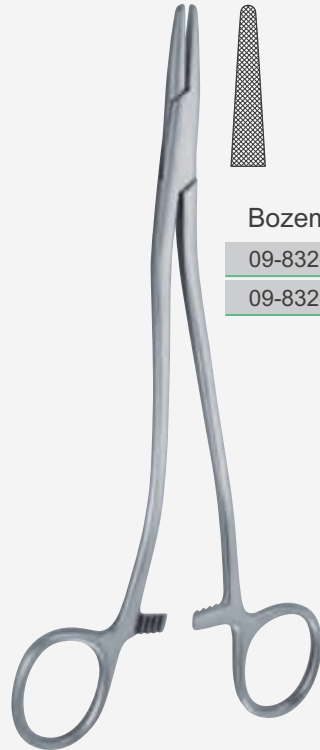

Bozemann (Wertheim)

09-832-20 20 cm - 8"

09-832-24 24 cm - 9 1/2"



Thomson-Walker  
 (Bozemann)

09-833-20

09-833-20T

20 cm - 8"



Olsen-Hegar

09-834-14 14 cm - 5 1/2"

09-834-17 17 cm - 6 3/4"

09-834-19 19 cm - 7 1/2"

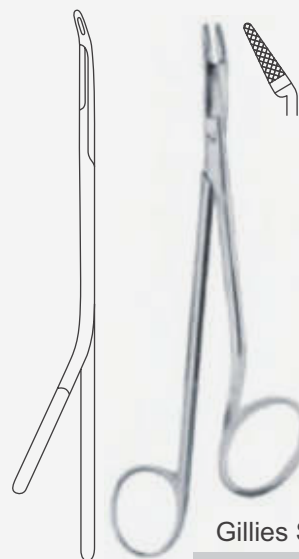

Gillies Slim

09-835-14

14.5 cm - 5 3/4"

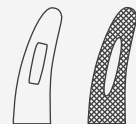

Gillies

09-836-16

16 cm - 6 1/4"



**Mathieu**

09-837-14	09-838-14	09-839-14	14 cm - 5 1/2"
09-837-17	09-838-17	09-839-17	17 cm - 6 3/4"
09-837-20	09-838-20	09-839-20	20 cm - 8"
09-837-24	09-838-24	09-839-24	24 cm - 9 1/2"

standard pattern  
standardmuster  
patrón estándar  
modèle standard  
modello standard

heavy pattern  
kräftiges Modell  
modelo fuerte  
modèle fort  
modello forte

delicate pattern  
schlankes Modell  
modelo delicado  
motif délicat  
modello delicato



**Kilner**

07-117-13	13.5 cm - 5 1/4"
07-117-18	18 cm - 7"



**Mathieu-Olsen**

09-840-14	14 cm - 5 1/2"
09-840-17	17 cm - 6 3/4"
09-840-20	20 cm - 8"

**Mathieu**

09-841-17	17 cm - 6 3/4"
09-841-20	20 cm - 8"

**Toennis**

09-842-18	18 cm - 7"
-----------	------------

**Lichtenberg**

09-843-17	17 cm - 6 3/4"
09-843-20	20 cm - 8"



**Castroviejo-Jacobson**

09-844-14
09-844-15
09-844-18
09-844-21

straight, without ratchet  
gerade, ohne Sperre  
recta, sin cremallera  
droit, sans crémaillère  
retto, senza cremagliera

smooth jaws  
glattes Maul  
boca lisa  
mors lisse  
morso liscio



09-845-14
09-845-15
09-845-18
09-845-21

straight, with ratchet  
gerade, mit Sperre  
recta, con cremallera  
droit, avec crémaillère  
retto, con cremagliera



09-846-14
09-846-15
09-846-18
09-846-21

curved, without ratchet  
gebogen, ohne Sperre  
curva, sin cremallera  
courbe, sans crémaillère  
curvo, senza cremagliera



09-847-14	14 cm - 5 1/2"
09-847-15	15 cm - 6"
09-847-18	18 cm - 7"
09-847-21	21 cm - 8 1/4"

curved, with ratchet  
gebogen, mit Sperre  
curva, con cremallera  
courbe, avec crémaillère  
curvo, con cremagliera



straight

09-254-15	09-255-15
with ratchet 1 mm	without ratchet 1 mm



curved

09-256-15	09-257-15	15 cm - 6"
with ratchet 1 mm	without ratchet 1 mm	



**Boynton**

09-848-12
12 cm - 4 3/4"

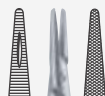

**Kalt**

09-849-14
14 cm - 5 1/2"



**Arruga**

09-850-16	09-851-16
16 cm - 6 1/4"	16 cm - 6 1/4"
straight gerade recta droit retto	curved gebogen curva courbe curvo







Hegar-Baumgartner

09-852-14T

14 cm - 5 1/2"



Baby-Crile-Wood

09-853-15T

15 cm - 6"

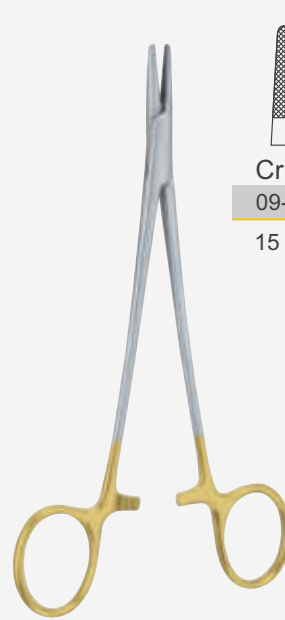

Crile-Wood

09-854-15T

15 cm - 6"



09-855-18T

18 cm - 7"



09-856-20T

20 cm - 8"



09-857-23T

23cm - 9"



09-858-26T

26 cm 10 1/4"



Derf (Wright)

09-859-12T

12 cm - 4 3/4"



Webster

09-860-13T

13 cm - 5"

smooth  
glatt  
lisa  
lisse  
liscio

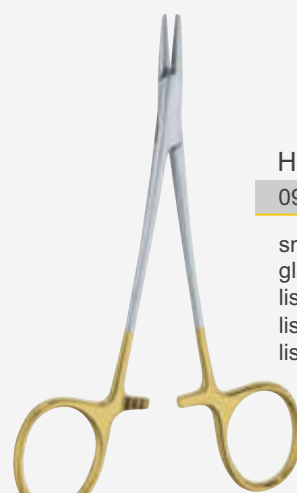

Halsey

09-861-13T

smooth  
glatt  
liso  
lisse  
liscio



09-862-13T

serrated  
gerieft  
estriada  
strié  
zigrinato

13 cm - 5"



**Kilner**

09-863-13T

13.5 cm - 5 1/4"



**Mayo-Hegar**

09-864-13T

13 cm - 5 1/4"

09-864-14T

14 cm - 5 1/2"

09-864-15T

15 cm - 6"

09-865-16T

16 cm - 6 1/4"



09-866-18T

18 cm - 7"

09-867-20T

20 cm - 8"

09-868-24T

24 cm - 9 1/2"

09-869-26T

26 cm - 10 1/4"



09-870-30T

30 cm - 12"



**Neivert (Masing)**

09-871-13T

13 cm - 5"

one ring angled  
 ein Ring abgewinkelt  
 un anillo acodado  
 une bague coudée  
 un anello angolato



**Converse**

09-872-13T

13 cm - 5"



**Mathieu-Olsen**

09-873-14T 14 cm - 5 1/2"

09-874-17T 17 cm - 6 3/4"

09-875-20T 20 cm - 8"



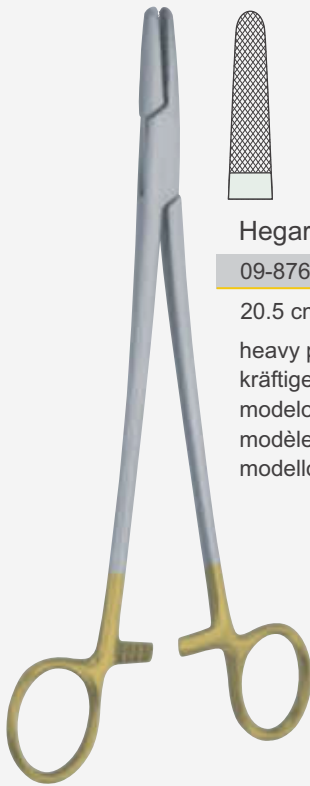

**Hegar**

09-876-20T

20.5 cm - 8 "

heavy pattern  
kräftiges Modell  
modelo fuerte  
modèle fort  
modello forte

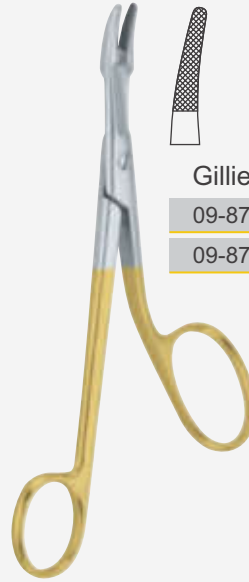

**Gillies**

09-877-14T 14.5 cm - 5 ¾"

09-877-16T 16 cm - 6 ¼"

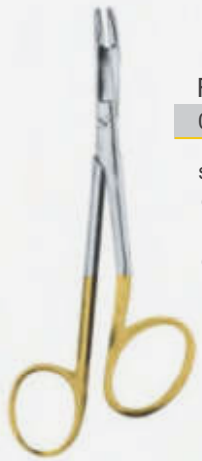

**Foster-Gillies**

09-878-12T

straight, serrated  
gerade, gerieft  
recta, estriada  
droit, strié  
retto, zigrinato



09-879-12T

straight, smooth  
gerade, glatt  
recta, lisa  
droit, lisse  
retto, liscio



09-880-12T

curved, serrated  
gebogen, gerieft  
curva, estriada  
courbe, strié  
curvo, zigrinato



09-881-12T 12 cm - 4 ¾"

curved, smooth  
gebogen, glatt  
curva, lisa  
courbe, lisse  
curvo, liscio

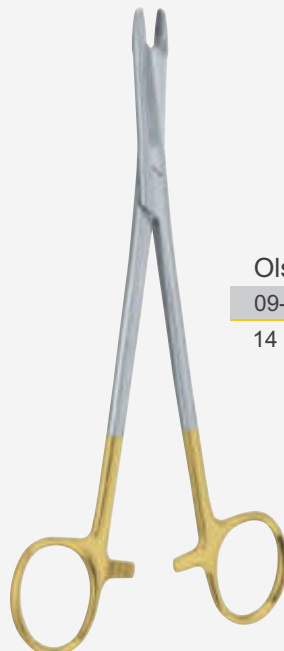

**Olsen-Hegar**

09-882-05T

14 cm - 5 ½"



09-883-17T

17 cm - 6 ¾"



09-884-19T

19 cm - 7 ½"



Stratte

09-885-23T

23 cm - 9 "



Heaney

09-886-16T 16 cm - 6 ¼"

09-886-18T 18 cm - 7 "

09-886-20T 20 cm - 8 "



Bozemann (Wertheim)

09-887-20T

20 cm - 8 "



09-888-24T

24 cm - 9 ½"



09-889-26T

26 cm - 10 ¼"



09-890-30T

30 cm - 12 "



Masson  
09-891-27T



Finochietto  
09-892-27T  
27 cm - 10 3/4"



Wangensteen  
09-893-27T  
27 cm - 10 3/4"



Mathieu

09-894-14T

14 cm - 5 1/2"



09-895-17T

17 cm - 6 3/4"



09-896-20T

20 cm - 8"



09-897-24T

24 cm - 9 1/2"



09-898-17T

17 cm - 6 3/4"

heavy pattern  
 kräftiges Modell  
 modelo fuerte  
 modèle fort  
 modello forte



09-899-20T

20 cm - 8"



09-900-14T

14 cm - 5 1/2"

delicate pattern  
 schlankes Modell  
 modelo delicado  
 motif délicat  
 modello delicato



09-901-17T

17 cm - 6 3/4"



09-902-20T

20 cm - 8"



09-903-24T

24 cm - 9 1/2"



**Mathieu**

09-904-17T

17 cm - 6 3/4"



09-905-20T

20 cm - 8"



**Lichtenberg**

09-906-17T

17 cm - 6 3/4"



09-907-20T

20 cm - 8"



**Hösel**

09-908-20T

20 cm - 8"

with long neck  
mit langem Hals  
con cuello largo  
avec col longue  
con collo lungo



09-909-25T

25 cm - 9 3/4"



**Hösel - Modified**

09-910-20T

20.5 cm - 8"

with long neck  
mit langem Hals  
con cuello largo  
avec col longue  
con collo lungo

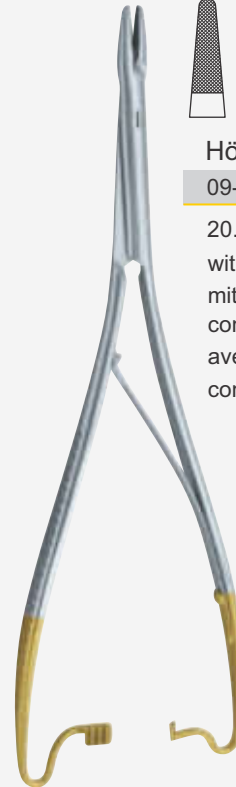



**Zweifel**  
 09-911-20T  
 20 cm - 8"



09-912-23T  
 23 cm - 9"



**Arruga**  
 09-913-16T  
 16 cm - 6 ¼"



09-914-16T  
 16 cm - 6 ¼"

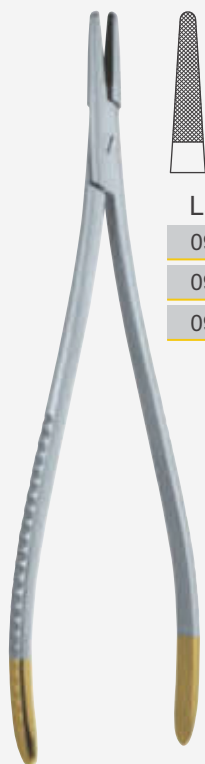

**Langenbeck**  
 09-915-18T 18 cm - 7 "  
 09-915-20T 20 cm - 8 "  
 09-915-23T 23 cm - 9 "

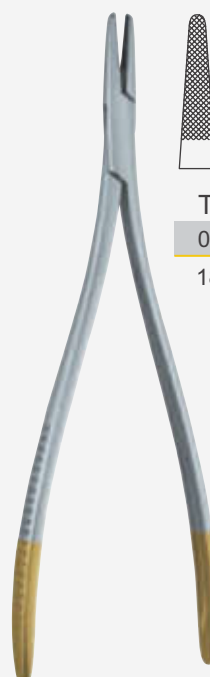

**Toennis**  
 09-916-18T  
 18 cm - 7 "





Sarot

09-917-18T

18 cm - 7 "



09-918-20T

20 cm - 8 "



09-919-26T

26 cm - 10 ¼"



De Bakey

09-920-18T

18 cm - 7 "



09-921-20T

20 cm - 8 "



09-922-23T

23 cm - 9 "



09-923-26T

26 cm - 10 ¼"



Wire -Twist

09-924-15T

09-924-18T

09-924-20T



09-925-15T 15 cm - 6 "

09-925-18T 18 cm - 7 "

09-925-20T 20 cm - 8 "

Wire forceps  
Drahtzange  
Pinza para hilos  
pince à fil  
pinza a filo

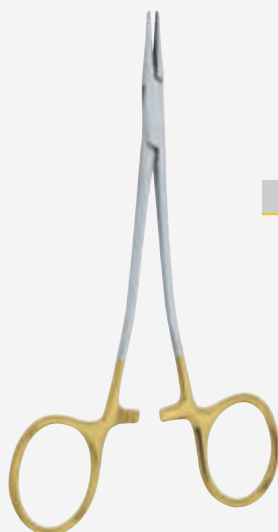

Model	Length
09-926-14T	14 cm - 5 1/2"
09-927-18T	18 cm - 7"
09-928-20T	20 cm - 8"
09-929-23T	23 cm - 9"



Model	Length
09-930-13T	13 cm - 5"
09-930-15T	15 cm - 6"
09-930-18T	18 cm - 7"
09-930-20T	20 cm - 8"
09-930-23T	23 cm - 9"
09-930-26T	26 cm - 10 1/4"



Model	Length
09-932-16T	16 cm - 6 1/4"
09-932-18T	18 cm - 7"
09-932-20T	20 cm - 8"
09-932-23T	23 cm - 9"
09-932-25T	25 cm - 9 3/4"



**De Bakey Slim**

09-933-13

13 cm - 5"

09-934-15

15 cm - 5 3/4"

09-935-17

17 cm - 6 3/4"

with special coated jaw  
mit Spezialbeschichtung im Maul  
boca con capa especial  
mors avec couche special  
morso con spalmatura speciale



09-936-18

18 cm - 7"

09-937-20

20 mm - 8"

09-938-23

23 cm - 9"

with special coated jaw  
mit Spezialbeschichtung im Maul  
boca con capa especial  
mors avec couche special  
morso con spalmatura speciale



**Ryder**

09-939-13 13 cm - 5"

09-939-15 15 cm - 6"

09-939-18 18 cm - 7"

09-939-20 20 cm - 8"

09-939-23 23 cm - 9"

with special coated jaw  
mit Spezialbeschichtung im Maul  
boca con capa especial  
mors avec couche special  
morso con spalmatura speciale



### Castroviejo-Jacobson

09-940-14T

09-941-14T

09-942-14T

09-943-14T 14 cm - 5 ½"

09-940-15T

09-941-15T

09-942-15T

09-943-15T 15 cm - 6 "

09-940-18T

09-941-18T

09-942-18T

09-943-18T 18 cm - 7 "

09-940-21T

09-941-21T

09-942-21T

09-943-21T 21 cm - 8 ¼"

straight, without ratchet  
gerade, ohne Sperre  
recta, sin cremallera  
droit, sans crémaillère  
retto, senza cremagliera

straight, with ratchet  
gerade, mit Sperre  
recta, con cremallera  
droit, avec crémaillère  
retto, con cremagliera

curved, without ratchet  
gebogen, ohne Sperre  
curva, sin cremallera  
courbe, sans crémaillère  
curvo, senza cremagliera

curved, with ratchet  
gebogen, mit Sperre  
curva, con cremallera  
courbe, avec crémaillère  
curvo, con cremaliera

smooth jaws  
glattes Maul  
boca lisa  
mors lisse  
morso liscio



### Vascular

09-944-18T

09-945-18T

09-946-18T

09-947-18T 18 cm - 7 "

straight, without ratchet  
gerade, ohne Sperre  
recta, sin cremallera  
droit, sans crémaillère  
retto, senza cremagliera

straight, with ratchet  
gerade, mit Sperre  
recta, con cremallera  
droit, avec crémaillère  
retto, con cremagliera

curved, without ratchet  
gebogen, ohne Sperre  
curva, sin cremallera  
courbe, sans crémaillère  
curvo, senza cremagliera

curved, with ratchet  
gebogen, mit Sperre  
curva, con cremallera  
courbe, avec crémaillère  
curvo, con cremaliera

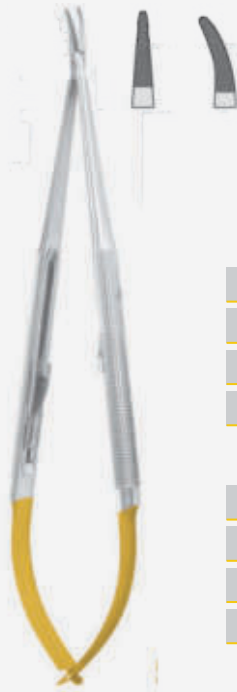

**Castroviejo - Barraquer**

07-333-14	14.5 cm - 5 3/4"
07-333-18	18/ cm - 7 "
07-333-21	21 cm - 8 1/4 "
07-333-23	23 cm - 9"

Round handle, straight

07-334-14	14.5 cm - 5 3/4"
07-334-18	18/ cm - 7 "
07-334-21	21 cm - 8 1/4 "
07-334-23	23 cm - 9"

Round handle, curved

07-335-14	14.5 cm - 5 3/4"
07-335-18	18/ cm - 7 "
07-335-21	21 cm - 8 1/4 "
07-335-23	23 cm - 9"

Round handle with lock, straight

07-336-14	14.5 cm - 5 3/4"
07-336-18	18/ cm - 7 "
07-336-21	21 cm - 8 1/4 "
07-336-23	23 cm - 9"

Round handle with lock, curved



**Jacobson**

07-337-15	15 cm - 6"
07-337-18	18/ cm - 7"
07-338-18	18/ cm - 7" Fine pattern
07-339-21	21 cm - 8 1/4 "
07-339-23	23 cm - 9"
07-340-23	23 cm - 9" Fine pattern
07-341-15	15 cm - 6"
07-341-18	18/ cm - 7 "
07-341-21	21 cm - 8 1/4 "
07-341-23	23 cm - 9"

Round handle, straight  
Diamond coated

**Jacobson**

07-342-15	15 cm - 6"
07-342-18	18/ cm - 7"
07-343-18	18/ cm - 7" Fine pattern
07-344-21	21 cm - 8 1/4 "
07-344-23	23 cm - 9"
07-345-23	23 cm - 9" Fine pattern
07-346-15	15 cm - 6"
07-346-18	18/ cm - 7 "
07-346-21	21 cm - 8 1/4 "
07-346-23	23 cm - 9"

Round handle, straight  
Diamond coated

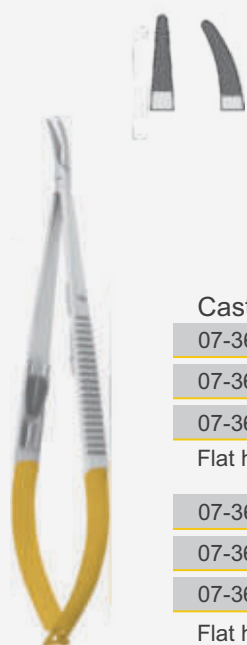

Castroviejo

07-360-14 14 cm - 5 1/2"

07-360-18 18/ cm - 7 "

07-360-21 21 cm - 8 1/4 "

Flat handle with lock, straight

07-361-14 15 cm - 5 1/2"

07-361-18 18/ cm - 7 "

07-361-21 21 cm - 8 1/4 "

Flat handle with lock, curved

07-362-14 14 cm - 5 1/2"

07-362-18 18/ cm - 7 "

07-362-21 21 cm - 8 1/4 "

Flat handle, straight

07-363-14 15 cm - 5 1/2"

07-363-18 18/ cm - 7 "

07-363-21 21 cm - 8 1/4 "

Flat handle, curved



Castroviejo

09-948-13T

straight, serrated jaws  
gerade, gerieftes Maul  
recta, boca estriada  
droit, mors strié  
retto, morso zigrinato



09-949-13T 13 cm - 5 "

curved, serrated jaws  
gebogen, gerieftes Maul  
curva, boca estriada  
courbe, mors strié  
curvo, morso zigrinato



**Castroviejo**  
09-950-13T  
130 mm – 5 "  
smooth jaws  
glattes Maul  
boca lisa  
mors strié  
morso liscio



**Barraquer**  
09-951-13T

curved, with ratchet  
gebogen, mit Sperre  
curva, con cremallera  
courbe, avec crémaillère  
curvo, con cremaliera



09-952-13T 130 mm – 5 "

curved, without ratchet  
gebogen, ohne Sperre  
curva, sin cremallera  
courbe, sans crémaillère  
curvo, senza cremagliera



**Boynton**  
09-953-12T  
12 cm - 4 ¾"



**Kalt**  
09-954-14T  
14 cm - 5 ½"

Muscular and skin suture needles  
 Haut- und Muskelnadeln  
 Agujas para suturas musculares y cutáneas  
 Aiguilles pour sutures musculaires et cutanées  
 Aghi da sutura muscolare e della pelle

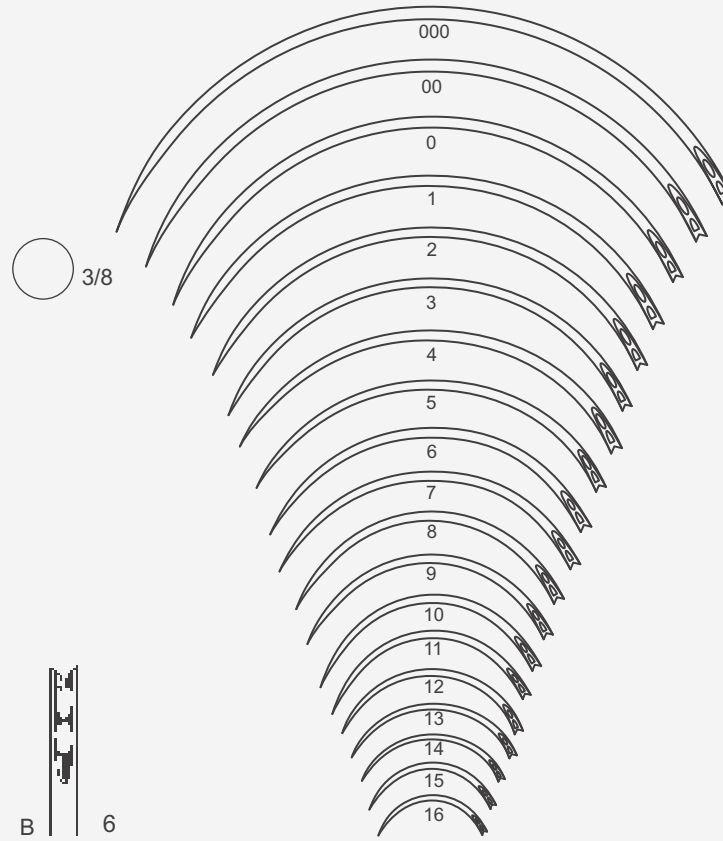

09-955-000 Fig. 000	09-956-00 Fig. 00	09-957-0 Fig. 0	09-958-1 Fig. 1	09-959-2 Fig. 2
09-960-3 Fig. 3	09-961-4 Fig. 4	09-962-5 Fig. 5	09-963-6 Fig. 6	09-964-7 Fig. 7
09-965-8 Fig. 8	09-966-9 Fig. 9	09-967-10 Fig. 10	09-968-11 Fig. 11	09-969-12 Fig. 12
09-970-13 Fig. 13	09-971-14 Fig. 14	09-972-15 Fig. 15	09-973-16 Fig. 16	



Pack of 12 Pieces



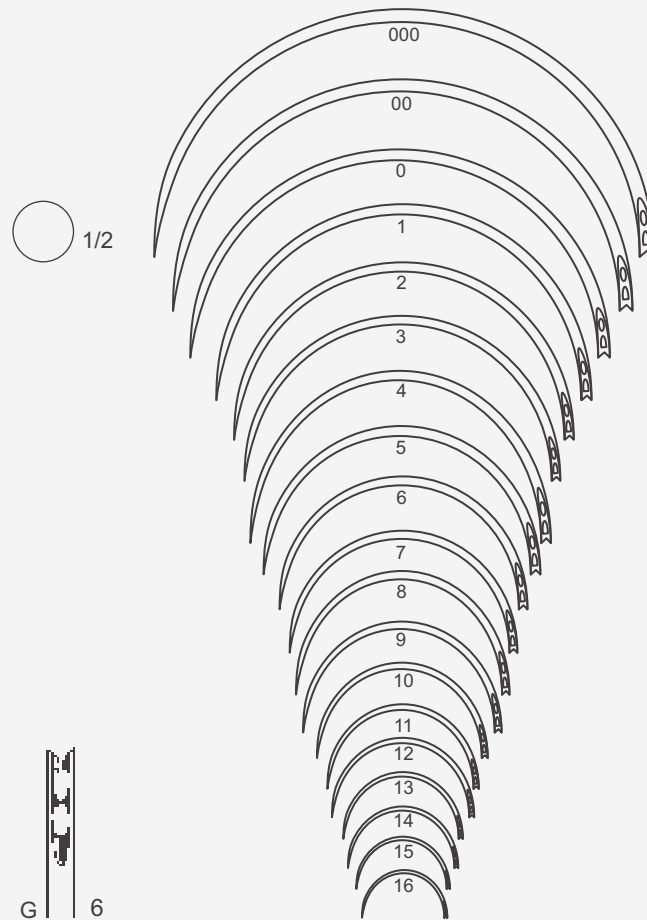

09-974-000

Fig.000

09-975-00

Fig.00

09-976-0

Fig.0

09-977-01

Fig. 1

09-978-02

Fig.2

09-979-03

Fig.3

09-980-04

Fig.4

09-981-05

Fig.5

09-982-06

Fig.6

09-983-07

Fig.7

09-984-08

Fig.8

09-985-09

Fig.9

09-986-10

Fig.10

09-987-11

Fig.11

09-988-12

Fig.12

09-989-13

Fig.13

09-990-14

Fig.14

09-991-15

Fig.15

09-992-16

Fig.16



Pack of 12 Pieces

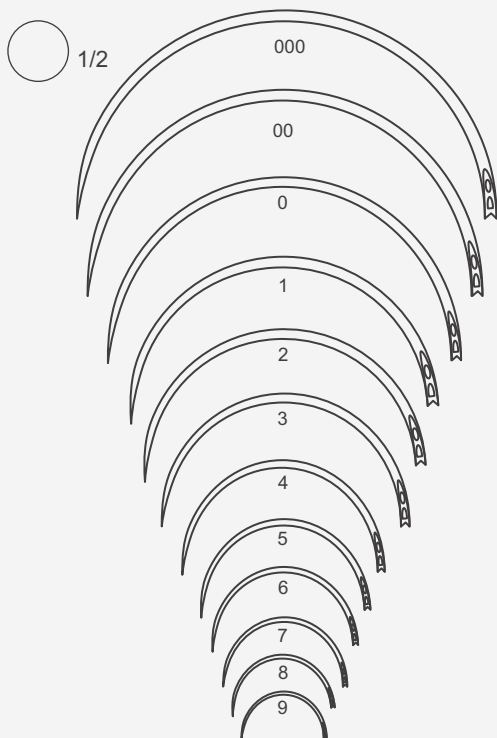

09-993-000 Fig. 000	09-994-00 Fig. 00	09-995-0 Fig. 0
09-996-01 Fig. 1	09-997-02 Fig. 2	09-998-03 Fig. 3
09-999-04 Fig. 4	09-100-05 Fig. 5	09-101-06 Fig. 6
09-102-07 Fig. 7	09-103-08 Fig. 8	09-104-09 Fig. 9

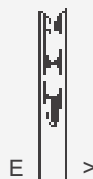
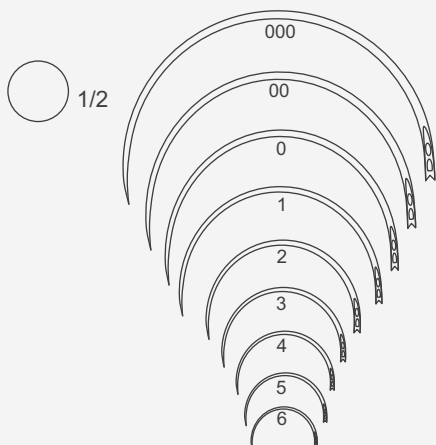

09-105-000 Fig. 000	09-106-00 Fig. 00	09-107-0 Fig. 0
09-108-01 Fig. 1	09-109-02 Fig. 2	09-110-03 Fig. 3
09-111-04 Fig. 4	09-112-05 Fig. 5	09-113-06 Fig. 6

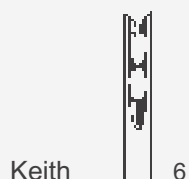
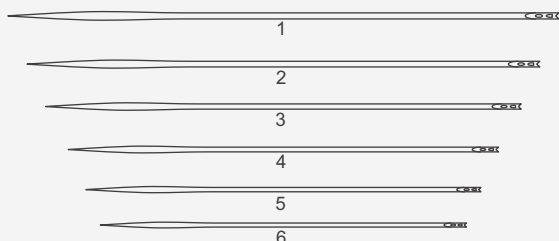

09-114-01 Fig. 1	09-115-02 Fig. 2	01-116-03 Fig. 3
09-117-04 Fig. 4	09-118-05 Fig. 5	09-119-06 Fig. 6
09-120-01 Fig. 1	09-121-02 Fig. 2	09-122-03 Fig. 3
09-123-04 Fig. 4	09-124-05 Fig. 5	09-125-06 Fig. 6

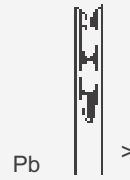
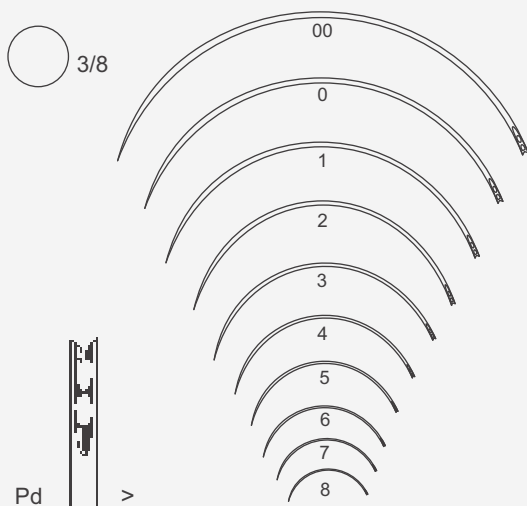
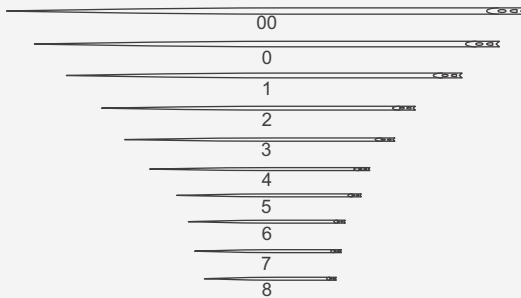
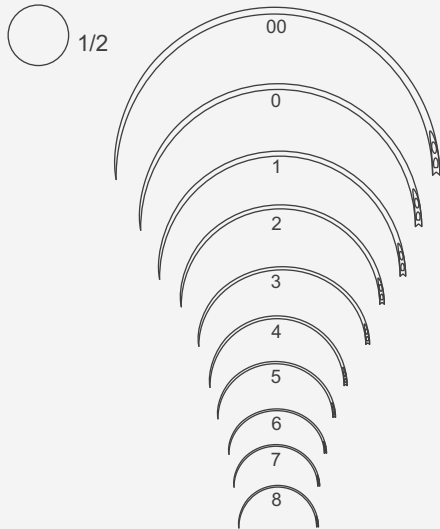

09-126-00	09-127-0	09-128-01
Fig.00	Fig.0	Fig.1

09-129-02	09-130-03
Fig.2	Fig.3

09-131-04	09-132-05	09-133-06
Fig.4	Fig.5	Fig.6

09-134-07	09-135-08
Fig.7	Fig.8

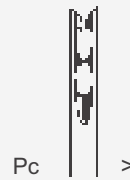

09-136-00	09-137-0	09-138-01
Fig.00	Fig.0	Fig.1

09-139-02	09-140-03
Fig.2	Fig.3

09-141-04	09-142-05	09-143-06
Fig.4	Fig.5	Fig.6

09-144-07	09-145-08
Fig.7	Fig.8

09-146-00	09-147-0	09-148-01
Fig.00	Fig.0	Fig.1

09-149-02	09-150-03
Fig.2	Fig.3

09-151-04	09-152-05	09-153-06
Fig.4	Fig.5	Fig.6

09-154-07	09-155-08
Fig.7	Fig.8

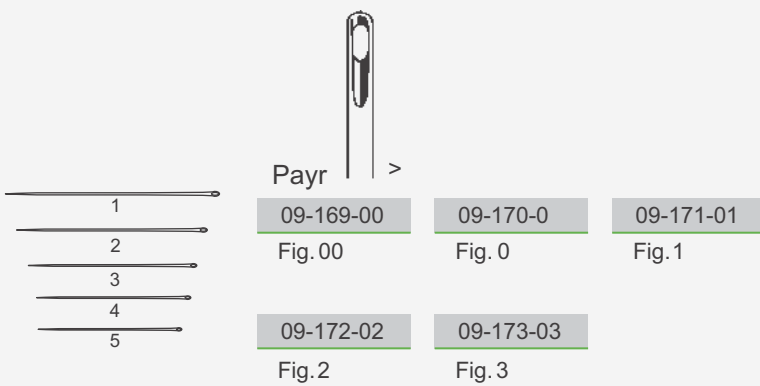
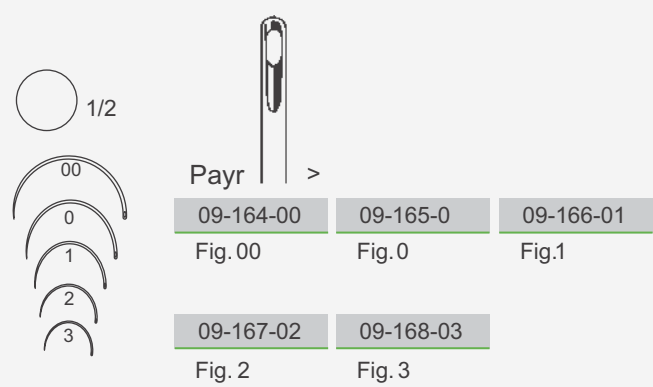
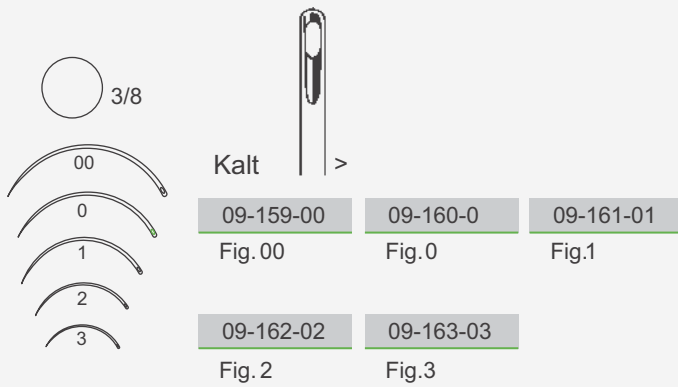
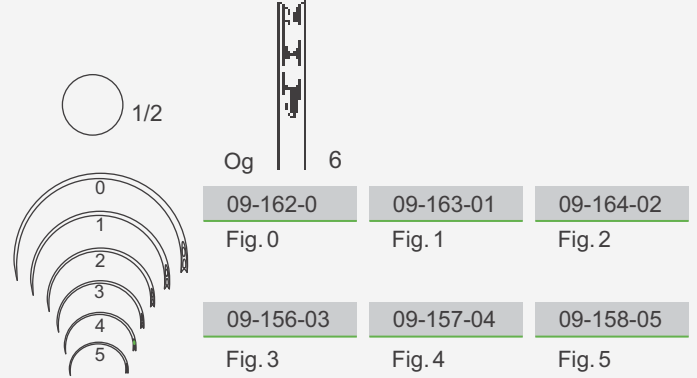
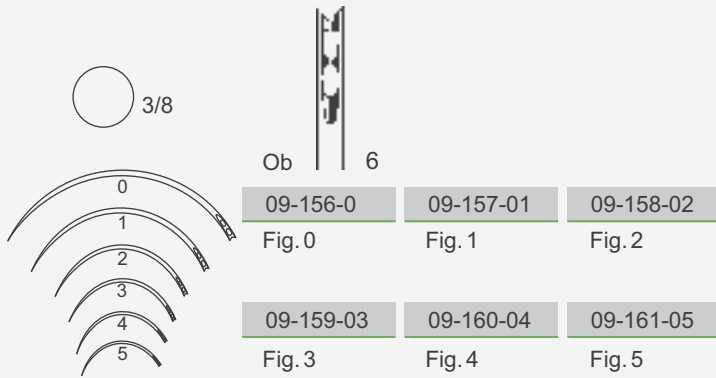



Reverdin

09-174-15	09-175-15	09-176-15	09-177-15	15 cm - 6"
09-174-19	09-175-19	09-176-19	09-177-19	19.5 cm - 7 3/4"
09-174-22	09-175-22	09-176-22	09-177-22	22.5 cm - 8 3/4"

Fig. 1

Fig. 2

Fig. 3

Fig. 4



Young

09-178-25

25 cm - 9 3/4"

Complete with one needle

Komplett mit einem Nadelaufsatz

Completo con una aguja

Complet avec une aiguille

Completo con un ago

Size 1



09-179-25

Spareneedle

Ersatznadel

Aguja de cambio

Aiguille de rechange

Ago di ricambio

Size 2



09-180-25

Size 3

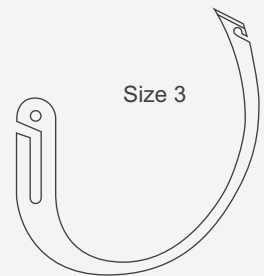

09-181-25



Gibson

09-182-20

20 cm - 8"

flexible  
biegsam  
maleable  
malléable  
flessibile



Cooper

09-183-19

19 cm - 7 1/2"

Kronecker

09-184-13

for right hand  
für die rechte Hand  
para la mano derecha  
pour la main droite  
per la mano destra

09-185-13 13 cm - 5"

for left hand  
für die linke Hand  
para la mano izquierda  
pour la main gauche  
per la mano sinistra





**Deschamps**

09-186-20
09-186-21
09-186-27

sharp  
scharf  
aguda  
pointue  
acuta

for right hand  
für die rechte Hand  
para la mano derecha  
pour la main droite  
per la mano destra



09-187-20
09-187-21
09-187-27

sharp  
scharf  
aguda  
pointue  
acuta

for left hand  
für die linke Hand  
para la mano izquierda  
pour la main gauche  
per la mano sinistra



09-188-20
09-188-21
09-188-27

blunt  
stumpf  
roma  
mousse  
smussa

for right hand  
für die rechte Hand  
para la mano derecha  
pour la main droite  
per la mano destra



09-189-20	20 cm - 8"
09-189-21	21 cm - 8 ¼"
09-189-27	27 cm - 10 ¾"

blunt  
stumpf  
roma  
mousse  
smussa

for left hand  
für die linke Hand  
para la mano izquierda  
pour la main gauche  
per la mano sinistra



**Rotter**

09-190-26

for right hand  
 für die rechte Hand  
 para la mano derecha  
 pour la main droite  
 per la mano destra



09-191-26

for left hand  
 für die linke Hand  
 para la mano izquierda  
 pour la main gauche  
 per la mano sinistra



09-192-26

for right hand  
 für die rechte Hand  
 para la mano derecha  
 pour la main droite  
 per la mano destra



09-193-26

26 cm - 10 1/4"

for left hand  
 für die linke Hand  
 para la mano izquierda  
 pour la main gauche  
 per la mano sinistra



**Schmieden**

09-194-21

21 cm - 8 1/4"



**Claus-Eicken**

09-195-23

23 cm - 9"



**Claus**

09-196-23

23 cm - 9"





**Hurd**

09-197-21

for right hand  
für die rechte Hand  
para la mano derecha  
pour la main droite  
per la mano destra



09-198-21 21 cm - 8 ¼"

for left hand  
für die linke Hand  
para la mano izquierda  
pour la main gauche  
per la mano sinistra



**Dupuy-Weiss**

09-199-22

for right hand  
für die rechte Hand  
para la mano derecha  
pour la main droite  
per la mano destra



09-200-22 22 cm - 8 ¾"

for left hand  
für die linke Hand  
para la mano izquierda  
pour la main gauche  
per la mano sinistra



**Yankauer**  
 09-201-17

Septumsuture needles  
 Septumnadeln  
 Aguja de sutura de septum  
 Aiguilles de sutures du septum  
 Aghi di sutura per setto



09-202-17



09-203-17



09-204-17



09-205-17 17 cm - 6 3/4"



09-206-17



09-207-17



09-208-17

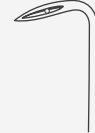

09-209-17 17 cm - 6 3/4"



**Nager**  
 09-210-24  
 24 cm - 9 1/2"



**Falk**  
 09-211-24  
 for right hand  
 für die rechte Hand  
 para la mano derecha  
 pour la main droite  
 per la mano destra



09-212-24 24 cm - 9 1/2"  
 for left hand  
 für die linke Hand  
 para la mano izquierda  
 pour la main gauche  
 per la mano sinistra



**Kirschner**

09-213-28

28 cm - 11"

4 mm

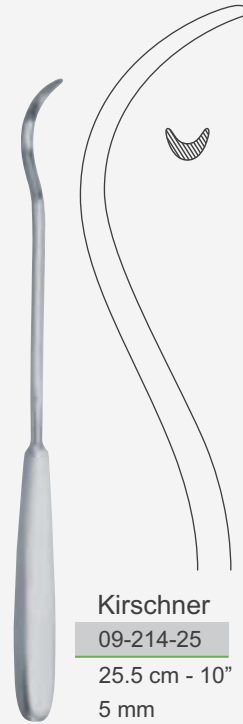

**Kirschner**

09-214-25

25.5 cm - 10"

5 mm

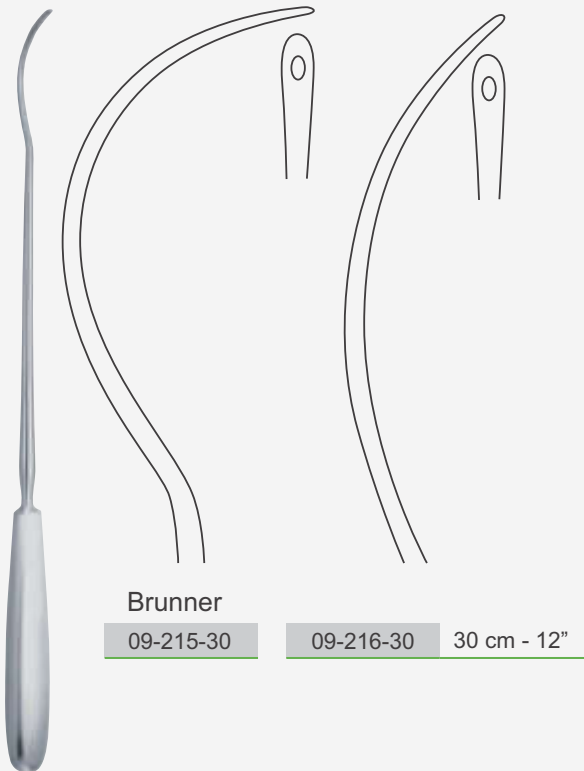

**Brunner**

09-215-30

09-216-30

30 cm - 12"

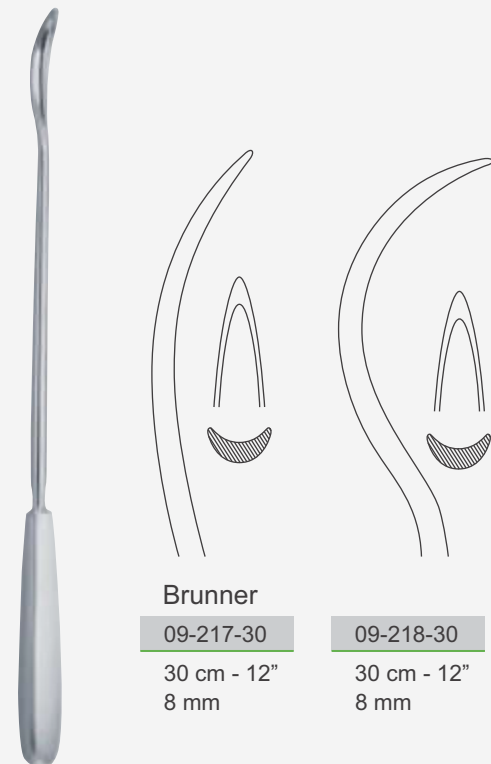

**Brunner**

09-217-30

30 cm - 12"  
8 mm

09-218-30

30 cm - 12"  
8 mm

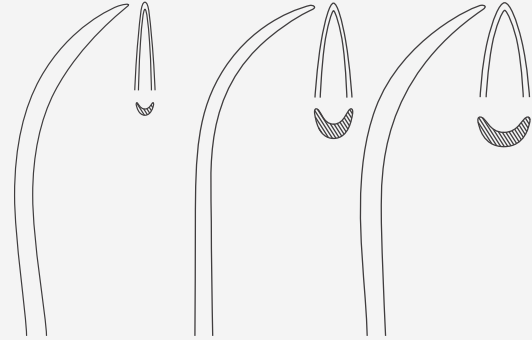

**König**

09-219-19

19 cm - 7 1/2"  
 2.5 mm

09-220-19

19 cm - 7 1/2"  
 5 mm

09-221-20

20 cm - 8"  
 7 mm



**Brunner**

09-222-18 18 cm - 7"

09-222-27 27 cm - 10 3/4"

Ferrozell



**Kirschner**

09-223-27 27 cm - 10 3/4"

Ferrozell



**Schmieden**

09-224-19

19 cm - 7 1/2"  
 8 mm



**Schmieden-Payr**

09-225-19

19 cm - 7 1/2"  
 8 mm

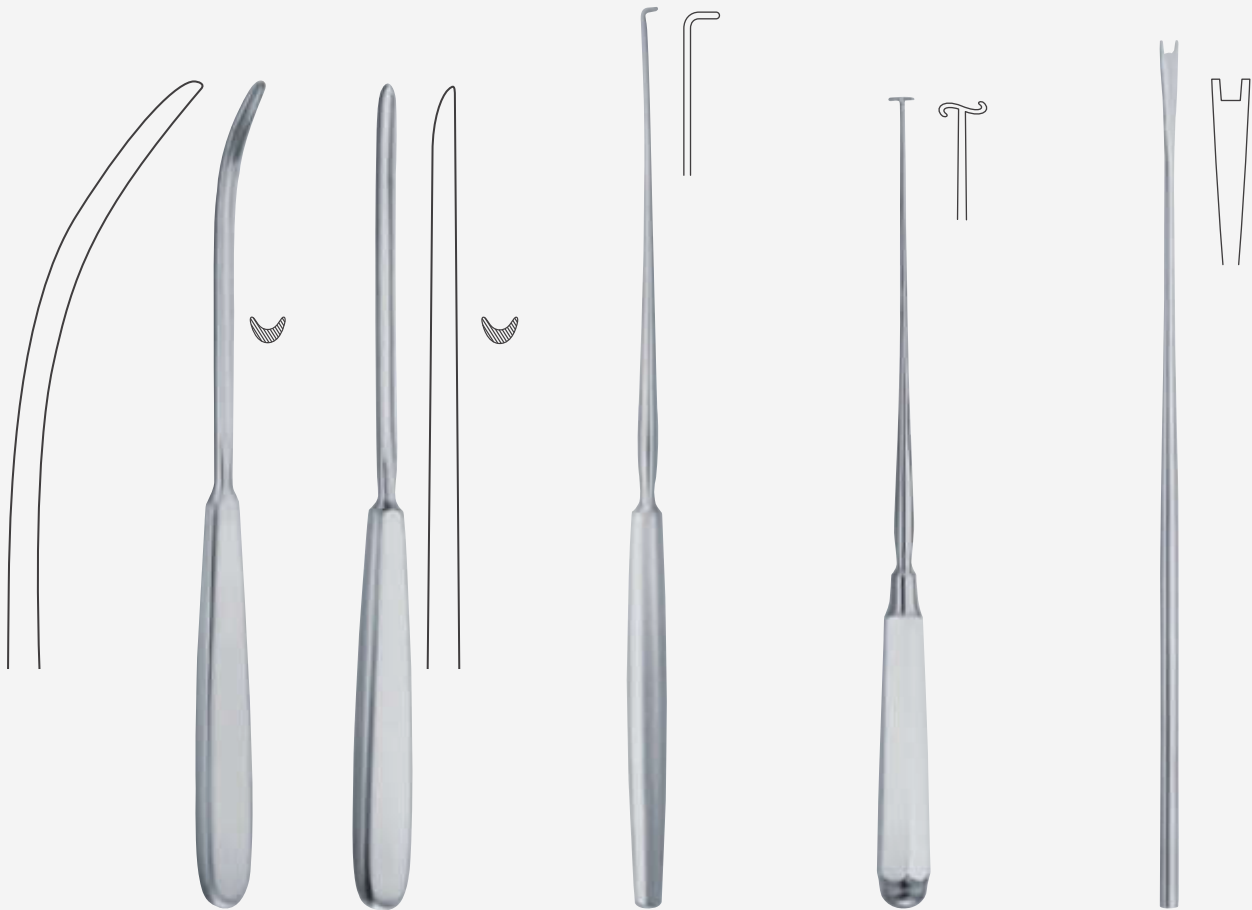

**Payr**

09-226-22

22 cm - 8 3/4"  
5 mm

09-227-22

22 cm - 8 3/4"  
5 mm

**Mod. Wien**

09-228-23

23.5 cm - 9 1/4"

Ligaturecatcher  
 Fadenfänger  
 Captador de hilos  
 Porte-ligature  
 Portalegature

**Bozemann**

09-229-21

21 cm - 8 1/4"

Knot tier  
 Schlingendreher  
 Tuerce-lazos  
 niveau de noeud  
 livello del nodo

**Adjuster**

09-230-23

23 cm - 9"

Ligature adjuster  
 Fadengabel  
 Horquilla de hilos  
 réglleur de lagature  
 Forchetta da sutura



Childe

09-231-18

18 cm - 7"

heavy pattern, with clip holder  
 kräftig, mit Klammerschiene  
 modelo fuerte, con barra para agrafes  
 modèle fort, avec porte-agrafe  
 modello forte, con portaagrafes



Michel

09-232-12

12 cm - 4 3/4"



Wachenfeldt

09-233-12

09-234-12

12.5 cm - 5"



Hegenbarth

09-235-12

12.5 cm - 5"



Collin

09-236-13

13 cm - 5"



Richter-Heath

09-237-14

14 cm - 5 1/2"



Michel  
09-238-12  
12 cm - 4 ¾



Michel  
09-239-12  
7,5 mm x 1,75 mm



09-240-12  
11 mm x 2 mm



09-241-12  
12 mm x 3 mm



09-242-12  
14 mm x 3 mm



09-243-12  
16 mm x 3 mm



09-244-12  
18 mm x 3 mm



09-245-12  
20 mm x 3 mm



09-246-12  
22 mm x 3 mm



Pack of 100 Piece





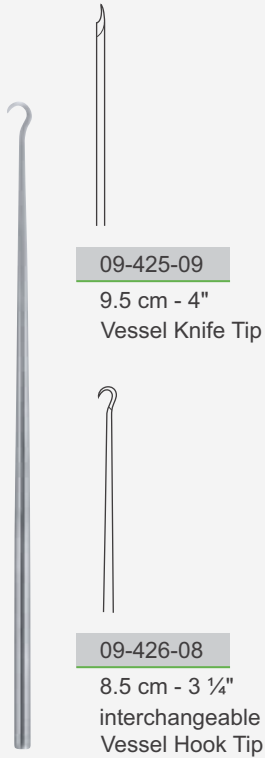

09-425-09

9.5 cm - 4"  
Vessel Knife Tip

09-426-08

8.5 cm - 3 1/4"  
interchangeable  
Vessel Hook Tip



Jacobson  
09-427-10

10.5 cm - 4 1/4"  
Handle with Chuck for inter-changeable  
Vessel Knives and Hooks



Jacobson  
09-430-18

18.5 cm - 7 1/4"  
Micro Vessel Knife



90°

09-428-18

18.5 cm - 7 1/4"  
curved

90°

Fisch

09-429-18

18.5 cm - 7 1/4"  
angled



**Yasargil**

09-431-18

18.5 cm - 7 1/4"  
 Micro Raspatory  
 angled



09-432-18

18.5 cm - 7 1/4"  
 Micro Dissector  
 angled

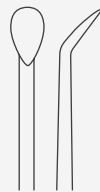

09-433-18

18.5 cm - 7 1/4"  
 Micro Raspatory  
 angled



09-434-18

18.5 cm - 7 1/4"  
 Micro Raspatory  
 slightly curved



09-435-18

18.5 cm - 7 1/4"  
 Micro Raspatory  
 strongly curved



**Yasargil**

09-436-18

18.5 cm - 7 1/4"  
 Micro Raspatory



09-437-18

18.5 cm - 7 1/4"  
 Micro Raspatory



09-438-18

18.5 cm - 7 1/4"  
 Micro Raspatory

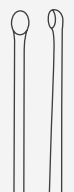

09-439-18

18.5 cm - 7 1/4"  
 Micro Spoon, sharp

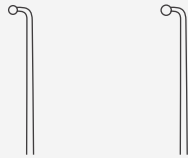

**Krayenbuhl**

09-440-19

19 cm - 7 1/2"

09-441-19

19 cm - 7 1/2"

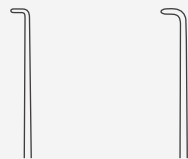

09-442-19

19 cm - 7 1/2"

09-443-19

19 cm - 7 1/2"



Fadenführer, geknöpft  
Ligature Guide, probe pointed

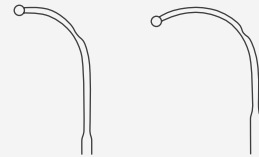

**Yasargil**

09-444-19

19 cm - 7 1/2"

09-445-19

19 cm - 7 1/2"



09-446-19

19 cm - 7 1/2"

09-447-19

19 cm - 7 1/2"



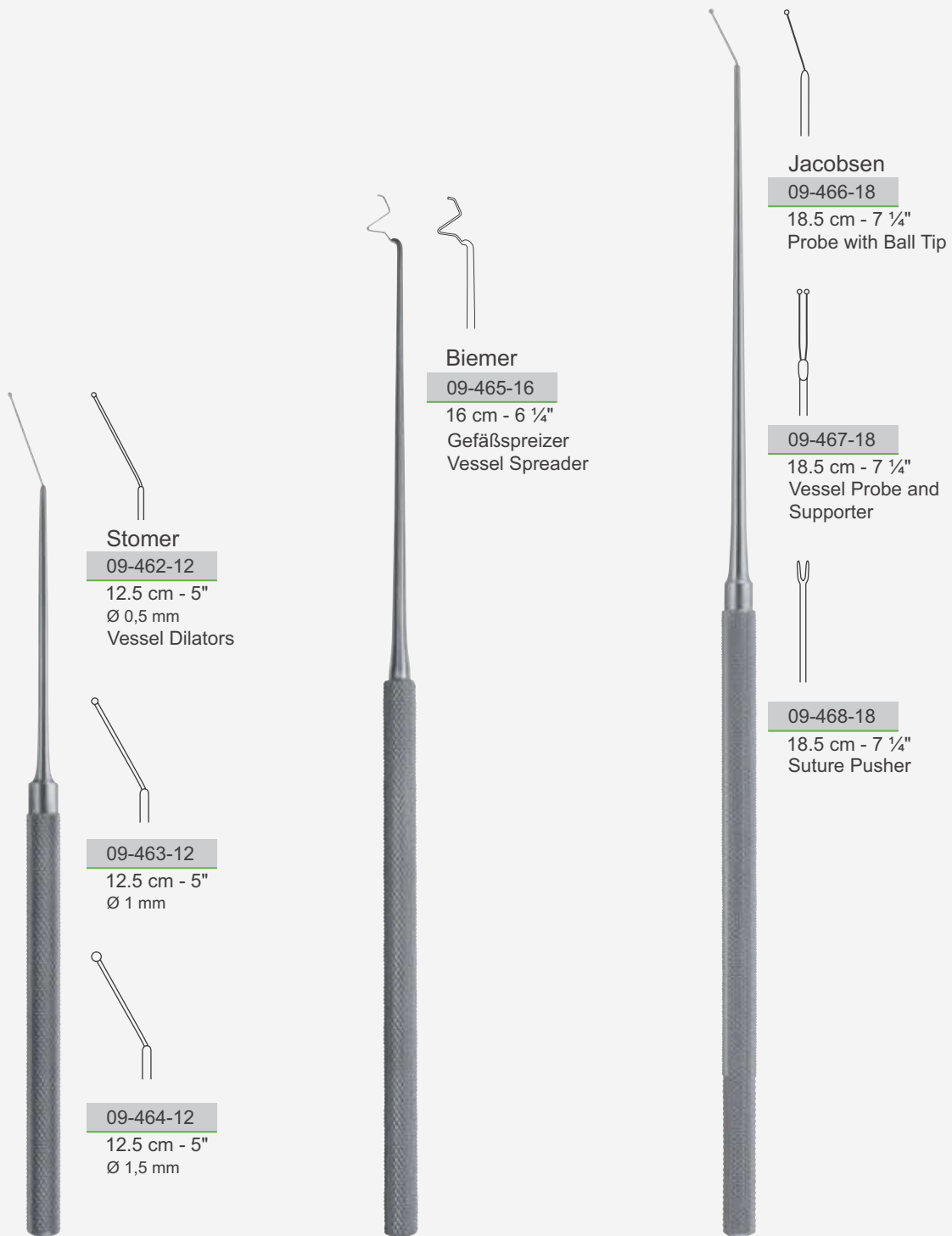



Case only

09-470-00

Stainless

Rhoton

09-469-00 Complete set consisting of:

09-470-00 Stainless case

1 of each 09-471-19 to 09-484-19

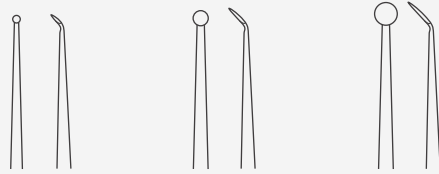

Dissectors, round

**Rhoton**

09-471-19

Fig. 1  
Ø1mm

09-472-19

Fig. 2  
Ø 2 mm

09-473-19

Fig. 3  
Ø 3 mm

19 cm - 7 1/2"

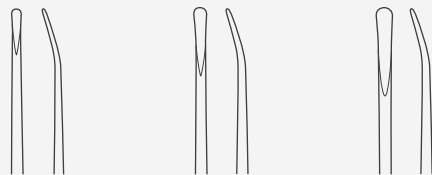

Dissectors, spatula shaped

09-474-19

Fig. 6  
1 mm

09-475-19

Fig. 7  
1,5 mm

09-476-19

Fig. 8  
2 mm

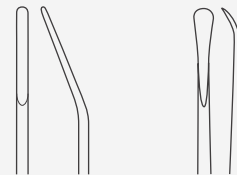

Elevators

09-477-19

Fig. 4  
1,2 mm

09-478-19

Fig. 5  
2,8 mm

19 cm - 7 1/2"



Needles, semi-sharp

09-479-19

19 cm - 7 1/2"  
Fig. 12



Hooks, blunt

09-480-19

19 cm - 7 1/2"  
Fig. 10  
2 mm  
90°

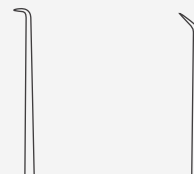

Hooks, semi-sharp

09-481-19

19 cm - 7 1/2"  
Fig. 9  
2 mm  
90°

09-482-19A

19 cm - 7 1/2"  
Fig. 11  
3 mm  
45°



Probes, angled,  
probe pointed

09-482-19B

19 cm - 7 1/2"  
Fig. 16  
3 mm  
90°



Curettes, sharp, oval

09-483-19

19 cm - 7 1/2"  
Fig. 13  
1 x 2 mm



Curettes, sharp,  
oval, angled down

09-484-19

19 cm - 7 1/2"  
Fig. 14  
1 x 2 mm  
45°



Probes, probe pointed

**Rhoton**

09-485-19

09-486-19

09-487-19

09-488-19

19 cm - 7 1/2"

Fig. 15

Fig. 17  
90°

Fig. 18  
40°

Fig. 19  
40°



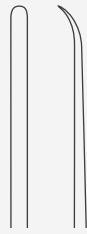

**Brewer**  
09-489-19

19 cm - 7 1/2"  
Dissectors  
2mm



09-490-19

19 cm - 7 1/2"  
Nerve Hooks  
5mm



09-491-19

19 cm - 7 1/2"  
Nerve Hooks  
8mm



**Samii**  
09-492-23

23 cm - 9"  
Knives for Tumor Tissue  
1,5 mm



09-493-23

23 cm - 9"  
3 mm

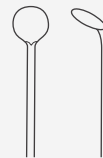

09-494-23

23 cm - 9"  
4,5 mm

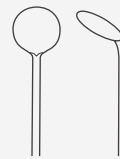

09-495-23

23 cm - 9"  
6 mm

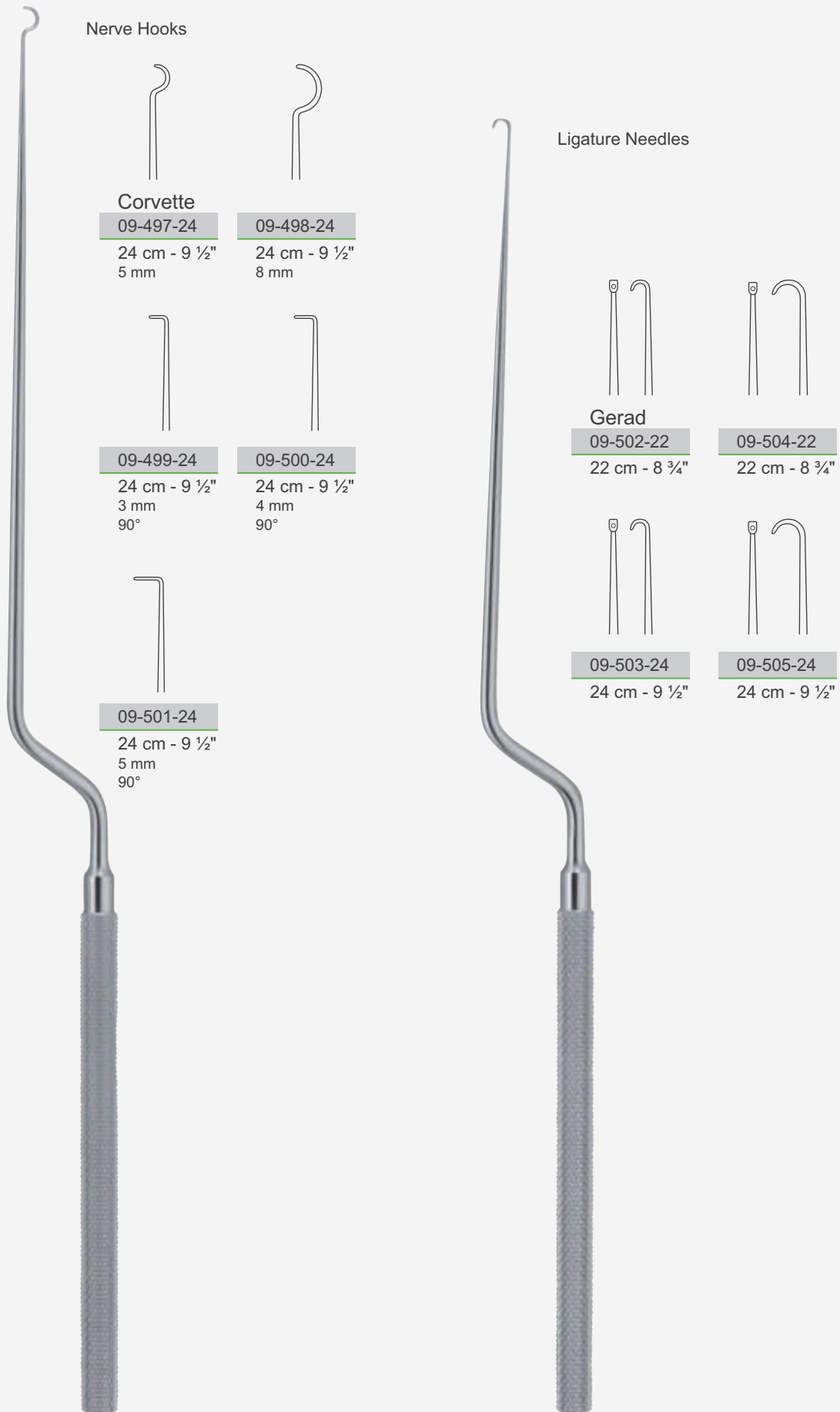



Spatula Dissectors



straight

Respa

09-506-25

25 cm - 10"  
5mm

Dissectors, angled

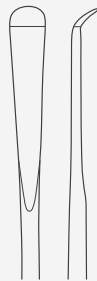

sharp, angled up

09-507-25

25 cm - 10"  
5 mm



sharp, angled down

09-508-25

25 cm - 10"  
5 mm

Raspatories



curved up

09-509-25

09-510-25



curved down

09-511-25

09-512-25

25 cm - 10" 2 mm

25 cm - 10" 4 mm



**Rigor**

09-513-24

09-514-24

09-515-24

09-516-24

Ø 2,5 mm  
 90°

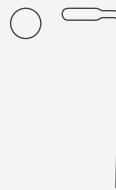

09-517-24

09-518-24

09-519-24

09-520-24

Ø 4 mm  
 90°

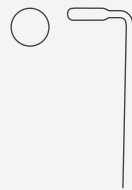

09-521-24

24 cm - 9 3/4" up

09-522-24

24 cm - 9 3/4" down

09-523-24

24 cm - 9 3/4" right

09-524-24

24 cm - 9 3/4" left

Ø 5 mm  
 90°



09-525-24

09-526-24

09-527-24

09-528-24

Ø 2,5 mm  
 45°

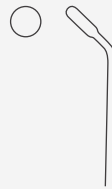

09-529-24

09-530-24

09-531-24

09-532-24

Ø 4 mm  
 45°

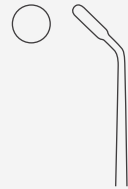

09-533-24

24 cm - 9 3/4" up

09-534-24

24 cm - 9 3/4" down

09-535-24

24 cm - 9 3/4" right

09-536-24

24 cm - 9 3/4" left

Ø 5 mm  
 45°

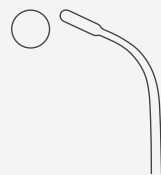

**Hardy**

09-537-24

curved left  
 Ø 5 mm

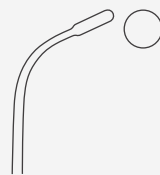

09-538-24

24 cm - 9 3/4"

curved right  
 Ø 5 mm



<b>Jorgenson</b>			
<b>09-539-24</b>	<b>09-540-24</b>	<b>09-541-24</b>	<b>09-542-24</b>
24 cm - 9 3/4" Ø 3 mm	24 cm - 9 3/4" Ø 3 mm 45°	24 cm - 9 3/4" Ø 3 mm 90°	24 cm - 9 3/4" Ø 3 mm 45°

with stick 5 mm		withstick 10 mm			
<b>09-544-24</b>	<b>09-548-24</b>	<b>09-552-24</b>	<b>up</b>	<b>09-553-24</b>	<b>down</b>
<b>09-545-24</b>	<b>09-549-24</b>	<b>09-553-24</b>	<b>down</b>	<b>09-554-24</b>	<b>right</b>
<b>09-546-24</b>	<b>09-550-24</b>	<b>09-554-24</b>	<b>right</b>	<b>09-555-24</b>	<b>left</b>
<b>09-547-24</b>	<b>09-551-24</b>	<b>09-555-24</b>	<b>left</b>		
24 cm - 9 3/4" Ø 3 mm 90°	24 cm - 9 3/4" Ø 3 mm 45°	24 cm - 9 3/4" Ø 3 mm 45°			

malleable



<b>09-557-24</b>	<b>09-558-24</b>
24 cm - 9 3/4" Ø 2,5 mm	24 cm - 9 3/4" Ø 3 mm
<b>09-560-24</b>	<b>09-561-24</b>
24 cm - 9 3/4" Ø 3,5 mm	24 cm - 9 3/4" Ø 4 mm



<b>Mhook</b>
<b>09-543-23</b>
23 cm - 9" 3 mm
<b>09-556-23</b>
23 cm - 9" 5 mm
<b>09-559-24</b>
23 cm - 9" 8 mm



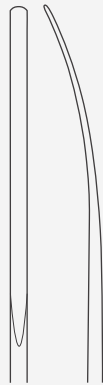

**Craig**

09-569-01	09-569-09	09-569-17	18.5 cm - 7 ¼"
09-569-02	09-569-10	09-569-18	18.5 cm - 7 ¼"
09-569-03	09-569-11	09-569-19	20 cm - 8"
09-569-04	09-569-12	09-569-20	20 cm - 8"
09-569-05	09-569-13	09-569-21	21.5 cm - 8 ½"
09-569-06	09-569-14	09-569-22	21.5 cm - 8 ½"
09-569-07	09-569-15	09-569-23	23 cm - 9"
09-569-08	09-569-16	09-569-24	23 cm - 9"
curved 4,5 mm	curved 1 mm	curved 3 mm	



Micro Spoon

**Hardy**

09-570-24  
24 cm - 9 ½"

	Item No.	Description
	Steima Fig. 1 09-571-00	Set consisting of:
	13-144-20	1 Micro scissors bayonet, 20 cm - 8"
	13-967-18	1 Welsh micro scissors, 18.5 cm - 7¼"
	13-213-18	1 Micro forceps, 18 cm - 7", 0.9 mm
	13-213-20	1 Micro forceps, 20 cm - 8", 0.9 mm
	13-328-20	1 Micro needle holder 20 cm - 8"
	07-360-18	1 Micro needle holder 20 cm - 8" TC
	21-516-05	1 Sterilization container
	21-628-01	1 Silicon matt
	21-609-05	1 Identification label red



	Item No.	Description
	<b>Steima</b> Fig. 2 09-572-00	Set consisting of:
	13-995-14	1 Irwan Micro scissors straight long blade 14.5 cm - 5 ½"
	13-996-14	1 Irwan Micro scissors curved long blade 14.5 cm - 5 ½"
	13-181-15	2 Micro forceps straight 15 cm - 6"
	13-299-05	1 Micro needle holder straight 15 cm - 6"
	13-300-05	1 Micro needle holder curved 15 cm - 6"
	21-516-05	1 Sterilization container
	21-628-01	1 Silicon matt
	21-609-05	1 Identification label red

	Item No.	Description
	Steima Fig. 3 09-573-00	Set consisting of:
	13-991-18	1 Irwan Micro scissors straight short blade 18 cm - 7"
	13-992-18	1 Irwan Micro scissors curved short blade 18 cm - 7"
	13-181-18	2 Micro forceps straight 18 cm - 7"
	13-179-20	1 Micro forceps straight 18 cm - 7"
	13-182-18	1 Micro forceps curved 18 cm - 7"
	13-299-06	1 Micro needle holder straight 18 cm - 7"
	13-300-06	1 Micro needle holder curved 18 cm - 7"
	21-516-05	1 Sterilization container
	21-628-01	1 Silicon matt
	21-609-05	1 Identification label red



**Hardy**

09-577-26

09-578-26

26 cm - 10 1/4"

09-577-26T

09-578-26T

26 cm - 10 1/4"

Ø 6 mm  
malleable

Ø 4 mm



Ray

09-579-18

09-580-18

18 cm - 9"

09-579-18T

09-580-18T

18 cm - 9"

horizontal 45°  
Ø 4 mm

vertical 45°  
Ø 4 mm



**Nicola**

09-581-26 26 cm - 10 ¼"

09-581-26T 26 cm - 10 ¼"

cutting to the right  
Ø 6,5 mm



09-582-26 26 cm - 10 ¼"

09-582-26T 26 cm - 10 ¼"

cutting to the left  
Ø 6,5 mm



09-583-26 26 cm - 10 ¼"

09-583-26T 26 cm - 10 ¼"

angled up  
Ø 6,5 mm



09-584-21 21.5 cm - 8 ½"

09-584-21T 21.5 cm - 8 ½"

Raspatory  
2 mm

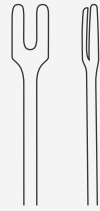

Hosobuchi

09-585-26

Fork Spatula, rigid

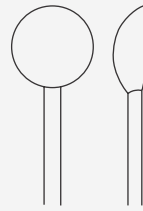

Landolt

09-586-26

26 cm - 10 ¼"

Spoon, malleable



Landolt

09-587-26

Hook, blunt, malleable

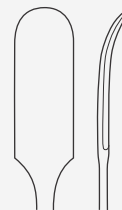

Landolt

09-589-26

Curette, malleable

Enucleator, blunt, malleable



Landolt

09-590-26

09-590-26T

left



09-591-26

09-591-26T

right



Landolt

09-592-26

09-592-26T

left



09-593-26

09-593-26T

right

26 cm - 10 ¼"

26 cm - 10 ¼"



09-594-24

09-594-24T

left bend  
right, sharp



09-595-24

09-595-24T

left bend  
left, sharp



09-596-24

09-596-24T

right bend  
right, sharp



09-597-24

09-597-24T

right bend  
left, sharp

24.5 cm - 9 3/4"

24.5 cm - 9 3/4"



09-598-24

09-598-24T

left bend  
right, blunt



09-599-24

09-599-24T

left bend  
left, blunt



09-600-24

09-601-24T

right bend  
right, blunt



innen scharf

09-602-24

09-602-24T

right bend  
left, blunt

24.5 cm - 9 3/4"

24.5 cm - 9 3/4"

Dissector, sharpened inner edge



Hardy-Fahlbusch

09-603-24

09-603-24T

left bend

09-604-24

09-604-24T

right bend

24.5 cm - 9 3/4"

24.5 cm - 9 3/4"

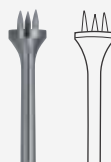

Hardy

09-605-24T

Implant Fork

24.5 cm - 9 3/4"

dissectors, Hooks, Curettes, Spoon, Raspatories  
 Dissektoren, Haken, Küretten, Löffel, Raspatories  
 disectores, Ganchos, Curetas, cuchara, Raspatories  
 dissecteurs, crochets, Curettes, cuillère, Raspatories  
 dissectori, Ganci, Curette, cucchiaio, Raspatories



**Landolt-reulen**

09-606-26

09-606-26T

Dissector, rigid  
 2 mm



**Landolt-reulen**

09-607-26 26 cm - 10 ¼"

09-607-26T 26 cm - 10 ¼"

Hook, blunt, rigid  
 1,7 mm



**Fahlbusch**

09-608-26

09-608-26T

Curette, malleable  
 2,5 mm



**Landolt-reulen**

09-609-26 26 cm - 10 ¼"

09-609-26T 26 cm - 10 ¼"

Curette, rigid  
 2,5 mm

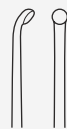

**Fahlbusch**

09-610-26 26 cm - 10 ¼"

09-610-26T 26 cm - 10 ¼"

Spoon, malleable  
 Ø 2 mm



**Landolt-reulen**

09-611-26

09-611-26T

Raspatories, rigid  
 2,2 mm



09-612-26 26 cm - 10 ¼"

09-612-26T 26 cm - 10 ¼"

Raspatories, rigid  
 3,2 mm













Cardiovascular Surgery  
Herz-Kreislauf-Chirurgie  
Cirugía Cardiovascular  
Chirurgie cardiovasculaire  
Chirurgia cardiovascolare

**comed**  
operate better with us

**10**

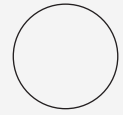
						
	Vasel					
	10-100-50	10-101-50	10-102-50	10-103-50	10-104-50	50 cm - 20"
	2 mmØ	3 mmØ	4 mmØ	5 mmØ	6 mmØ	
						
	10-105-50	10-106-50	10-107-50	10-108-50	50 cm - 20"	
	8.5 mmØ	10 mmØ	12 mmØ	14 mmØ		



Favoe  
 10-109-12  
 12 cm - 4 3/4"

Rumel-Belmont

10-110-32	10-111-32	32.5 cm - 12 3/4"
3.2 mm Ø for children für Kinder para niños pour enfants per bambini	6.4 mm Ø for adults für Erwachsene para adultos pour adultes per adulti	

Tourniquet  
 Tourniquet  
 Tourniquete  
 Tourniquet  
 Tourniquet



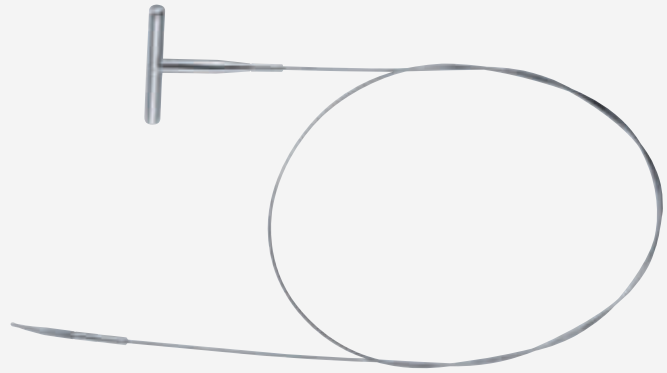

**Nabatof**

10-112-00	Complete set consisting of:
10-113-00	Metal case 135 mm x 100 mm x 25 mm
10-114-00	Handle
10-115-00	Cable
10-116-00	Probe tip in plastic
10-117-00	Probe
10-118-00	Tip 6 mm
10-119-00	Tip 9 mm
10-120-00	Tip 12 mm
10-121-00	Tip 15 mm

10-113-00

Metal case

10-114-00

Handle

10-115-00

Cable 900 mm

10-116-00

Probe tip in plastic



10-117-00

3 mm Ø  
Probe



10-118-00

6 mm Ø  
Olive



10-119-00

9 mm Ø



10-120-00

12 mm Ø



10-121-00

15 mm Ø



**Biemer**

10-122-00

applying forceps with lock  
 Anlegepinzette mit Schloss  
 aplicadora con cierre  
 pince à poser avec verrou  
 pinza posa clips con cremagliera

10-123-00

applying forceps without lock  
 Anlegepinzette ohne Schloss  
 aplicadora sin cierre  
 pince à poser sans verrou  
 pinza posa clips senza cremagliera



x

jaw length  
 Maullänge  
 longitud de la boca  
 longueur du mors  
 lunghezza del morso

y

max. jaw opening  
 max. Maulöffnung  
 apertura max. de la boca  
 ouverture max. du mors  
 apertura mass.

gms

closing pressure  
 Schließkraft  
 fuerza de cierre  
 force de fermeture  
 pressione



10-124-00

x = 6 mm  
 y = 4 mm  
 gms = 30–40



10-125-00

x = 9 mm  
 y = 5 mm  
 gms = 30–40



10-126-00

x = 9 mm  
 y = 5 mm  
 gms = 20–25

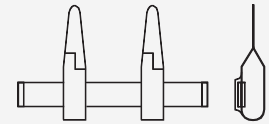

10-127-00

x = 4.5 mm  
 y = 3.0 mm  
 gms = 30–40

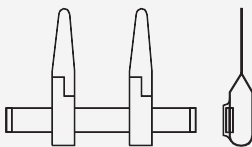

10-128-00

x = 9 mm  
 y = 5 mm  
 gms = 30–40

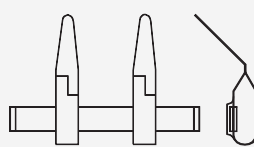

10-129-00

x = 9 mm  
 y = 5 mm  
 gms = 30–40

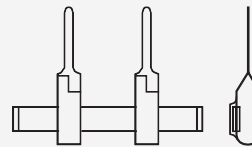

10-130-00

x = 9 mm  
 y = 5 mm  
 gms = 20–25

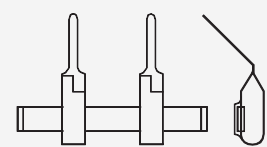

10-131-00

x = 9 mm  
 y = 5 mm  
 gms = 30–40

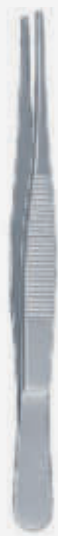

A-Forceps  
Fig. 1

10-132-14 10-133-14 14 cm - 5 1/2"

with lock  
mit Schloß  
con cierre  
avec serrure  
con cremagliera



A-Forceps  
Fig. 2

10-134-14 14 cm - 5 1/2"

for approximators and double-clips  
für Approximatoren und Doppelklemmen  
para aproximadores y clips dobles  
pour approximateurs et clips doubles  
per approssimatori e clips doppi



x	Ø	V	A
Length	Vessel	Vein	Artery
Länge	Gefäß	Vene	Arterie
Longitud	Vaso	Vena	Arteria
Longueur	Vaisseau	Veine	Artère
Lunghezza	Vaso	Vena	Arteria



10-135-01

10-135-02



10-136-01

10-136-02



10-137-01

10-137-02



10-138-01

10-138-02

x = 8 mm

V

A

Ø = 0,4 mm-1 mm



10-139-01

10-139-02

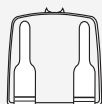

10-140-01

10-140-02

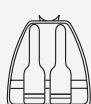

10-141-01

10-141-02

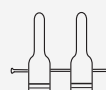

10-142-01

10-142-02

x = 11 mm

V

A

Ø = 0,6 mm-1,5 mm



10-143-01

10-143-02

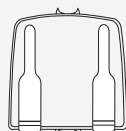

10-144-01

10-144-02

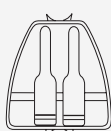

10-145-01

10-145-02

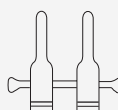

10-146-01

10-146-02

x = 14 mm

V

A

Ø = 1 mm-2 mm



10-147-01

10-147-02

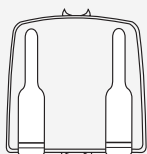

10-148-01

10-148-02

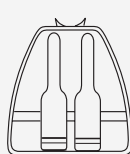

10-149-01

10-149-02

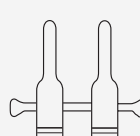

10-150-01

10-150-02

x = 17 mm

V

A

Ø = 1 mm-2,25 mm



10-151-01

10-151-02

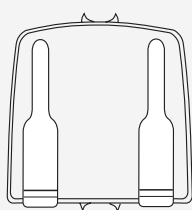

10-152-01

10-152-02

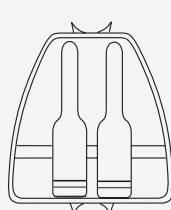

10-153-01

10-153-02

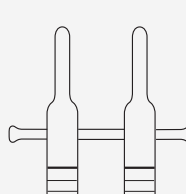

10-154-01

10-154-02

x = 25 mm

V

A

Ø = 1,5 mm-3,5 mm



10-155-01

10-155-02

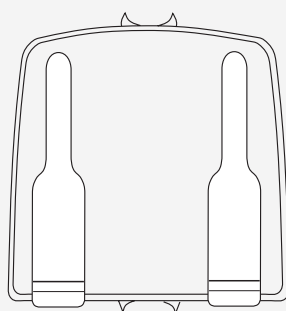

10-156-01

10-156-02

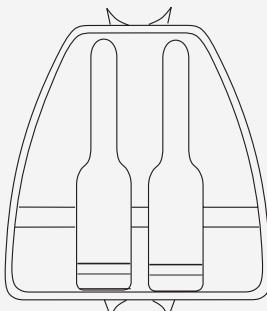

10-157-01

10-157-02

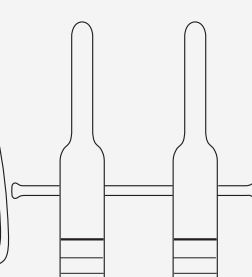

10-158-01

10-158-02

x = 36 mm

V

A

Ø = 1,5 mm-3,5 mm

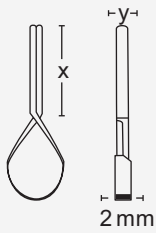

x = Jaw length  
x = Maullänge  
x = Longitud de la boca  
x = Longueur du mors  
x = Lunghezza del morso

y = max. opening  
y = max. Maulöffnung  
y = Apertura max. de la boca  
y = Ouverture max. du mors  
y = Apertura mass. del morso

gms = Pressure  
gms = Schließkraft  
gms = Presión  
gms = Force de fermeture  
gms = Sforza della chiusura

for temporary closure  
für temporären Verschluss  
para oclusión temporal  
pour fermeture temporaire  
per chiusura temporanea



10-159-00

x = 10.0 mm  
y = 1.5 mm  
gms = 70

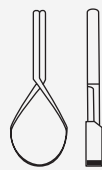

10-160-00

x = 8.0 mm  
y = 1.0 mm  
gms = 70

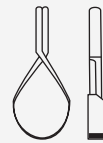

10-161-00

x = 6.0 mm  
y = 0.8 mm  
gms = 70

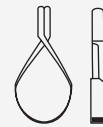

10-162-00

x = 4.0 mm  
y = 0.75 mm  
gms = 70

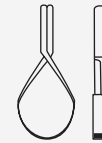

10-163-00

x = 6.0 mm  
y = 1.0 mm  
gms = 70



10-164-00

x = 6.0 mm  
y = 1.0 mm  
gms = 70

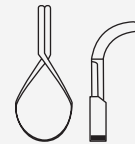

10-165-00

x = 6.0 mm  
y = 1.0 mm  
gms = 70

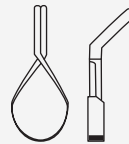

10-166-00

x = 6.0 mm  
y = 1.0 mm  
gms = 70

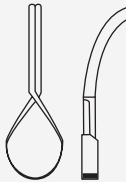

10-167-00

x = 10.0 mm  
y = 1.0 mm  
gms = 70



### Baggi

10-168-15

15 cm - 6"  
with ratchet  
mit Sperre  
con cierre  
avec crémaillère  
con cremagliera

10-169-18

18 cm - 7"  
with ratchet, bayonet shaped  
mit Sperre, bajonettförmig  
con cierre, en forma de bayoneta  
avec crémaillère, en forme de baionette  
con cremagliera, a forma baionetta

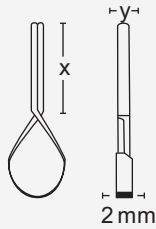

x = Jaw length  
 x = Maullänge  
 x = Longitud de la boca  
 x = Longueur du mors  
 x = Lunghezza del morso

y = max. opening  
 y = max. Maulöffnung  
 y = Apertura max. de la boca  
 y = Ouverture max. du mors  
 y = Apertura mass. del morso

gms = Pressure  
 gms = Schließkraft  
 gms = Presión  
 gms = Force de fermeture  
 gms = Sforza della chiusura

for temporary closure  
 für temporären Verschluss  
 para oclusión temporal  
 pour fermeture temporaire  
 per chiusura temporanea

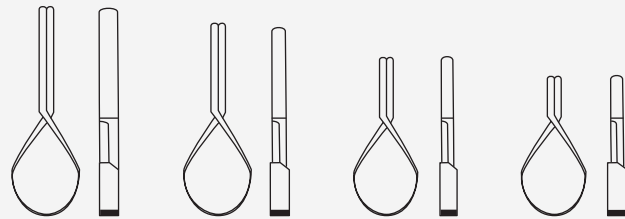

10-170-00

x = 10.0 mm  
 y = 2.0 mm  
 gms = 150

10-171-00

x = 8.0 mm  
 y = 2.0 mm  
 gms = 150

10-172-00

x = 6.0 mm  
 y = 1.0 mm  
 gms = 150

10-173-00

x = 4.0 mm  
 y = 0.75 mm  
 gms = 150

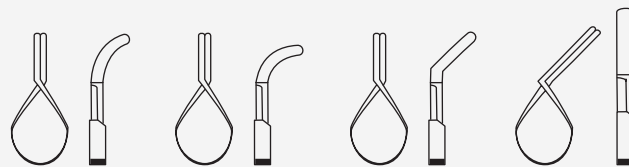

10-174-00

x = 6.0 mm  
 y = 1.0 mm  
 gms = 150

10-175-00

x = 6.0 mm  
 y = 1.0 mm  
 gms = 150

10-176-00

x = 6.0 mm  
 y = 1.0 mm  
 gms = 150

10-177-00

x = 8.0 mm  
 y = 2.0 mm  
 gms = 150





Johns Hopkins

10-178-03	10-179-05	10-180-05	10-181-06	10-182-07	10-183-07	10-184-09
3.8 cm - 1½"	5 cm - 2"	5.5 cm - 2¼"	6.5 cm - 2½"	7 cm - 2¾"	7.5 cm - 3"	9 cm - 3½"

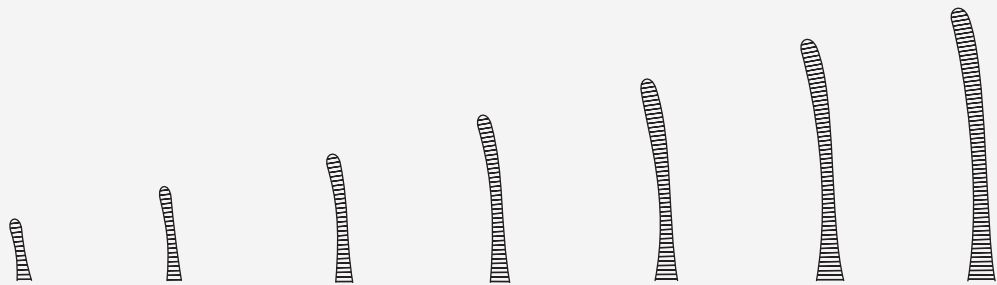

Johns Hopkins

10-185-03	10-186-05	10-187-05	10-188-06	10-189-07	10-190-07	10-191-09
3.8 cm - 1½"	5 cm - 2"	5.5 cm - 2¼"	6.5 cm - 2½"	7 cm - 2¾"	7.5 cm - 3"	9 cm - 3½"



Fridous

10-192-23

23.5 cm - 9¼"

Applying forceps for bulldog clamps  
Anlegezange für Bulldogklemmen  
Pinza aplicadora para clamps Bulldog  
Pince pour poser les clamps Bulldog  
Pinza per posizionare le pinze Bulldog



Schwartz

10-001-19

19 cm - 7½"



Applicator

10-002-01	10-002-02	10-002-03
2.7 cm - 1"	2.7 cm - 1"	2.7 cm - 1"



Dieffenbach

10-003-03	10-004-03	3.5 cm - 1½"
10-003-05	10-004-05	5 cm - 2"
10-003-06	10-004-06	6 cm - 2"

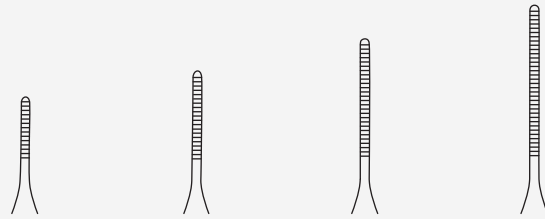

**Diethrich**

10-193-05

8 mm

10-194-05

12 mm

10-195-05

16 mm

10-196-05

20 mm

5 cm - 2"

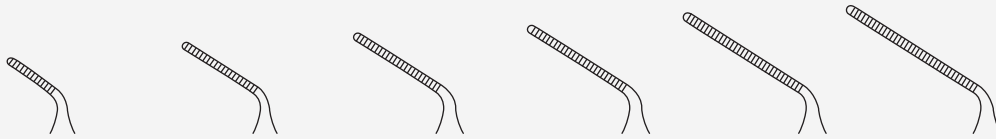

**Diethrich**

10-197-05

8 mm

10-198-05

12 mm

10-199-05

13 mm

10-200-05

16 mm

10-201-05

18 mm

10-202-05

20 mm

5 cm - 2"

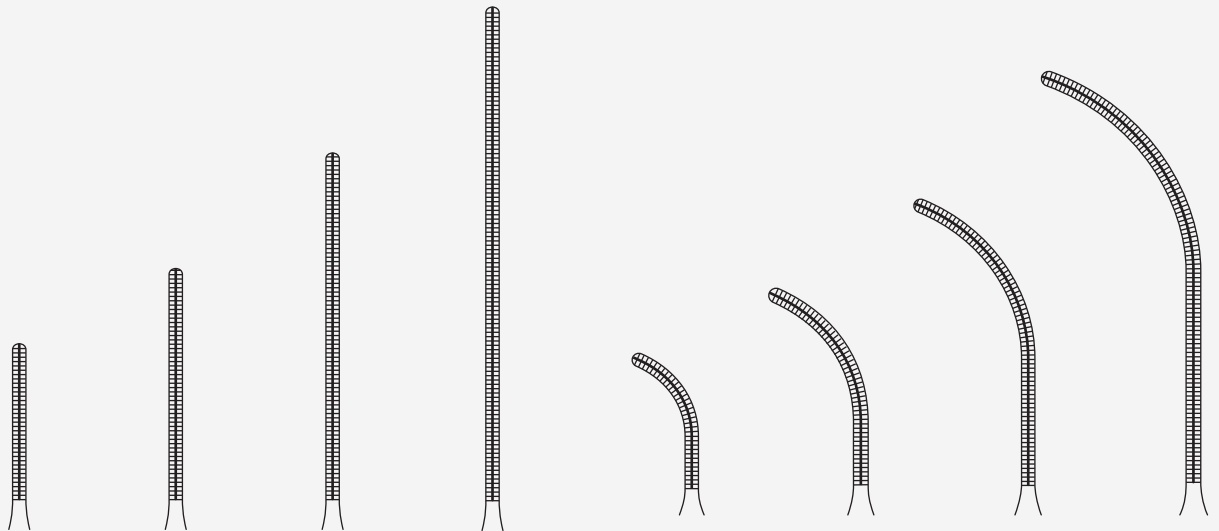

**Cooley**

10-203-08

8 cm - 3 1/4"

10-204-09

9 cm - 3 1/2"

10-205-10

10.5 cm - 4 1/4"

10-206-12

12.5 cm - 5"

10-207-07

7.5 cm - 3"

10-208-08

8.5 cm - 3 1/4"

10-209-09

9.5 cm - 3 3/4"

10-210-11

11.5 cm - 4 1/2"



De Bakey  
10-211-07  
7.5 cm - 3"



10-212-08  
8.5 cm - 3 1/4"



10-213-10  
10.5 cm - 4 1/4"



10-214-12  
12 cm - 4 3/4"

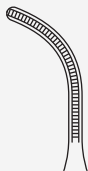

De Bakey  
10-215-07  
7 cm - 2 3/4"

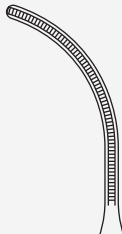

10-216-08  
8 cm - 3 1/4"

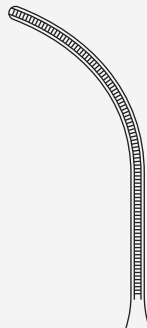

10-217-10  
10 cm - 4"

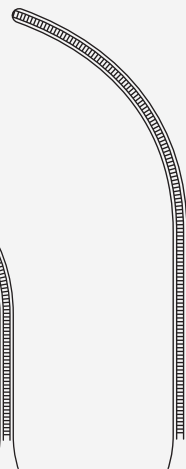

01-218-11  
11.5 cm - 4 1/2"

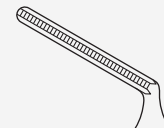

10-219-05  
5 cm - 2 1/4"  
angled on flat  
abgewinkelt  
angulado  
coudée sur le plat  
angolato



Glover  
 10-220-06  
 6 cm - 2 1/2"



10-221-07  
 7 cm - 2 3/4"



10-222-09  
 9 cm - 3 1/2"



10-223-11  
 11 cm - 4 1/4"

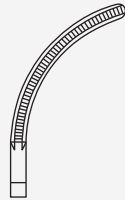

Glover  
 10-224-05  
 5.5 cm - 2 1/4"

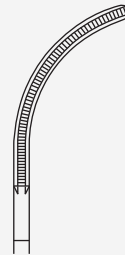

10-225-06  
 6.5 cm - 2 1/2"

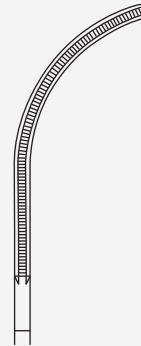

10-226-08  
 8.5 cm - 3 1/4"

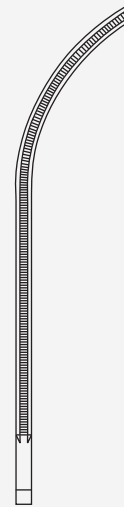

10-227-10  
 10.5 cm - 4 1/4"

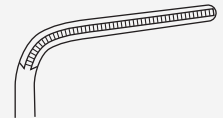

10-228-05  
 5 cm - 2"  
 angled on flat  
 abgewinkelt  
 angulado  
 coudée sur le plat  
 angolato



De Bakey-Satinsky

10-229-07

7 cm - 2 3/4"



De Bakey-Carotis

10-230-09

9 cm - 3 1/2"

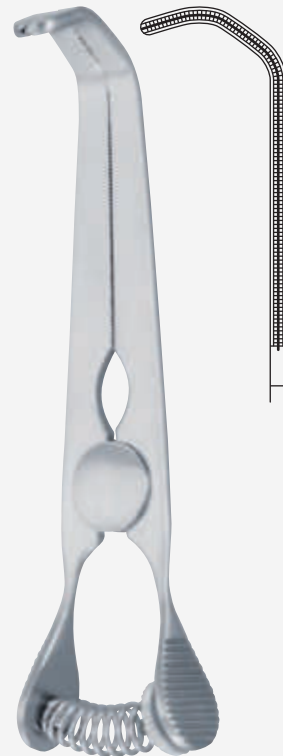

De Bakey-Satinsky

10-231-10

10 cm - 4"

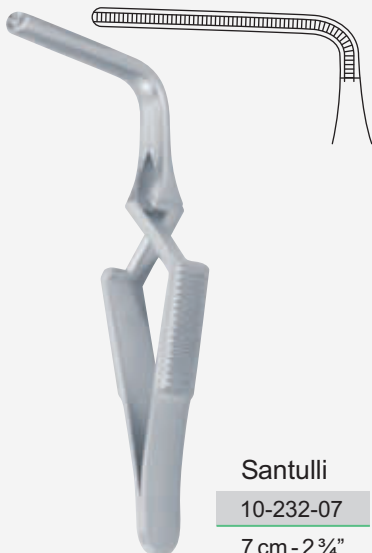

Santulli

10-232-07

7 cm - 2 3/4"

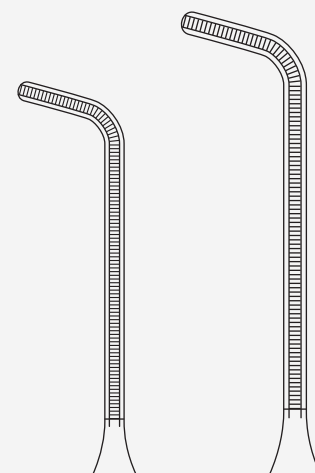

Gregory-soft

10-233-09

9 cm - 3 1/2"

10-234-11

11 cm - 4 1/4"

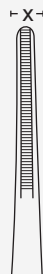

**Mercury**

10-246-15	10-247-15	15 cm - 6"
10-246-20	10-247-20	20 cm - 8"
10-246-24	10-247-24	24 cm - 9 1/2"

x = 2.5 mm

x = 3.0 mm

stainless  
 rostfrei  
 inoxidable  
 inoxydable  
 inossidabile

10-248-15	10-249-15	150 mm - 6"
10-248-20	10-249-20	20 cm - 8"
10-248-24	10-249-24	24 cm - 9 1/2"

x = 2.5 mm

x = 2.8 mm

Titanium



Potts

10-250-20

20 cm - 8"



10-251-22

22 cm - 8 3/4"

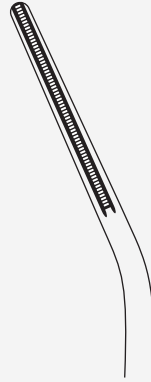

10-252-20

20 cm - 8"

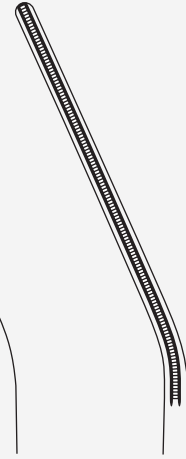

10-253-22

22 cm - 8 3/4"



Potts

10-254-22

22 cm - 8 3/4"



10-255-21

21 cm - 8 1/4"

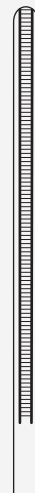

10-256-22

22 cm - 8 3/4"

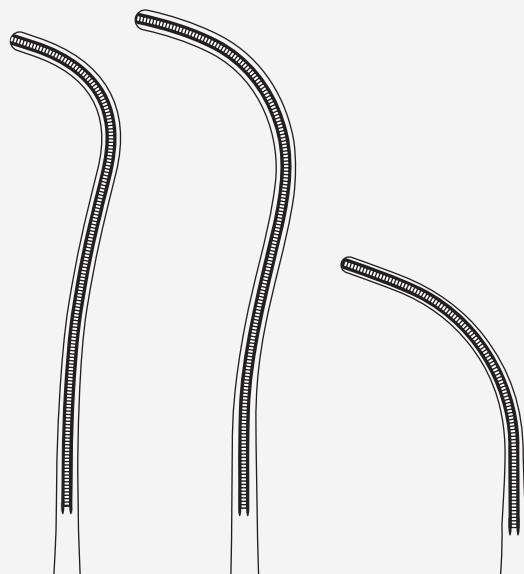

De Bakey

10-257-19

19 cm - 7 1/2"

10-258-23

23 cm - 9"

10-259-16

16 cm - 6 1/4"







Bainbridge,  
light

10-265-15  
15 cm 6"



10-266-18  
18 cm 7"



10-267-15  
15 cm 6"



10-268-18  
18 cm 7"

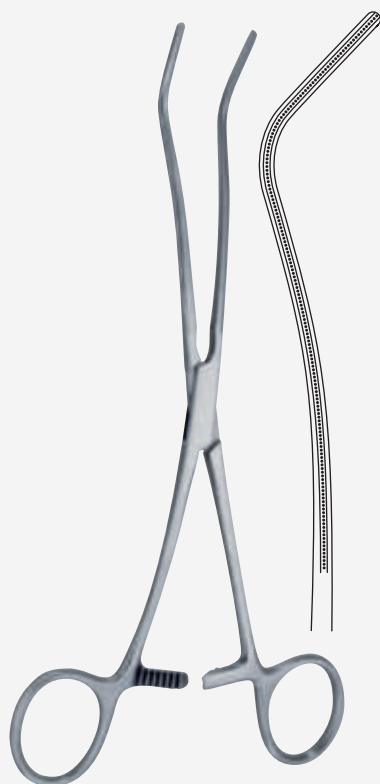

De Bakey

10-269-20

20 cm - 8"  
 S-curved  
 S-förmiggebogen  
 curva en S  
 courbe en S  
 curva a forma S

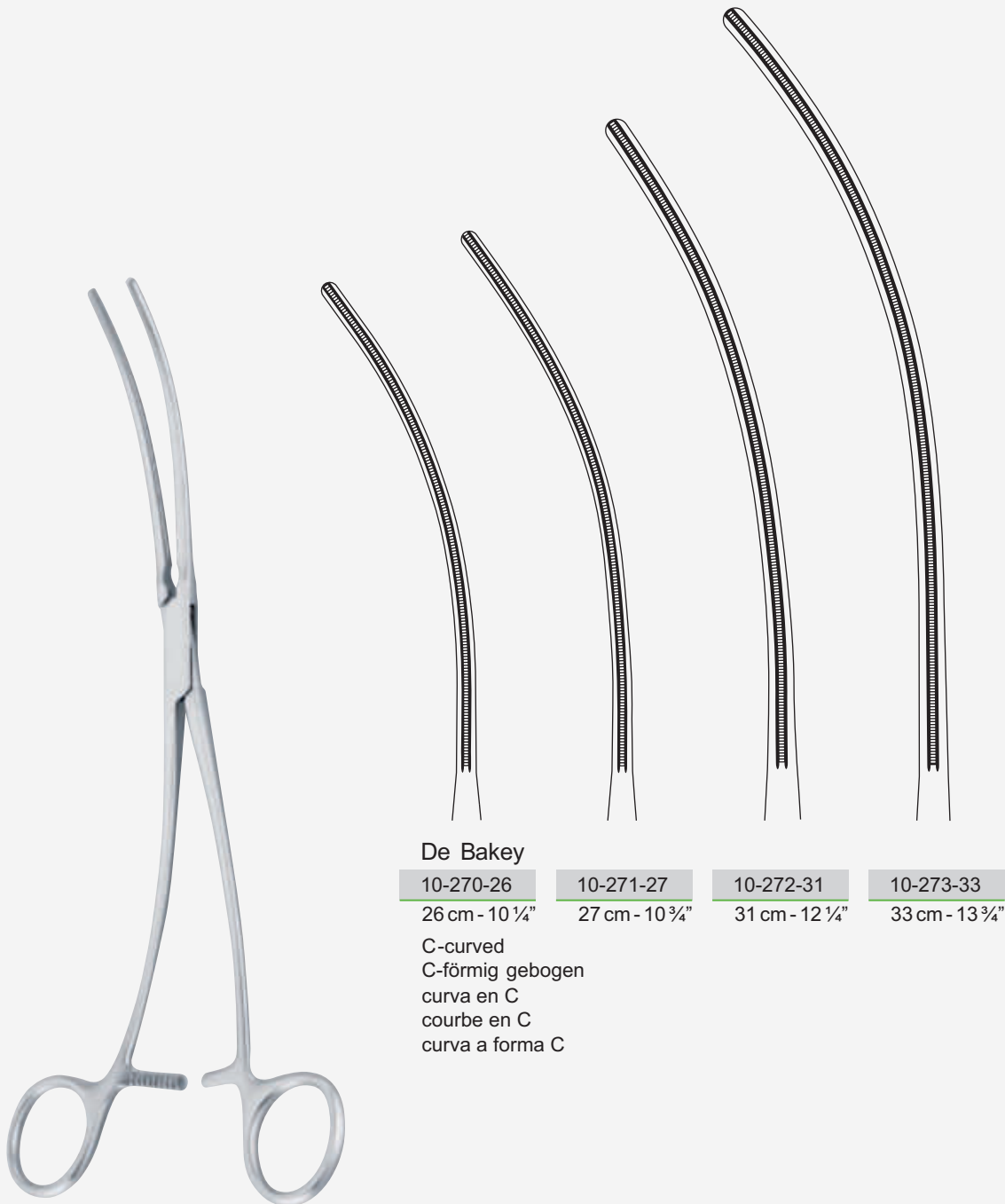

**De Bakey**

10-270-26

26 cm - 10 1/4"

10-271-27

27 cm - 10 3/4"

10-272-31

31 cm - 12 1/4"

10-273-33

33 cm - 13 3/4"

C-curved  
C-förmig gebogen  
curva en C  
courbe en C  
curva a forma C



De Bakey  
10-274-28  
28 cm - 11"



Brixton  
10-275-30  
30 cm - 11 3/4"  
S-curved  
S-förmiggebogen  
curva en S  
courbe en S  
curva a forma S



Weber

10-276-26

26 cm - 10 1/4"

curved left

links gebogen

curva a la izquierda

courbe à gauche

curvata a sinistra

Weber

10-277-26

26 cm - 10 1/4"

curved right

rechts gebogen

curva a la derecha

courbe à droite

curvata a destra

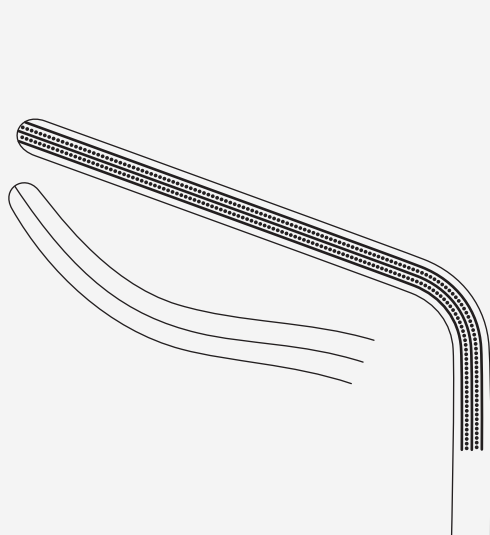

De Bakey  
10-278-27  
27 cm - 10 3/4"

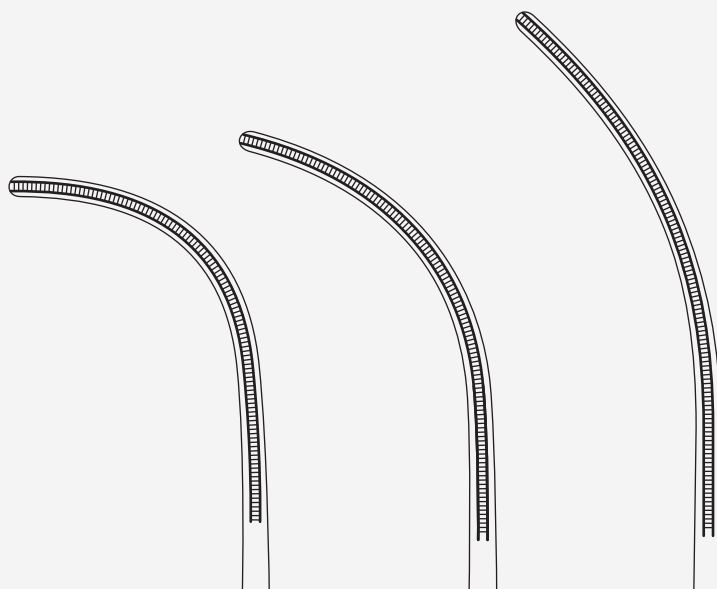

De Bakey-  
Bahnson  
10-279-24  
24 cm - 9 1/2"

10-280-25  
25 cm - 9 3/4"

10-281-26  
26 cm - 10 1/4"

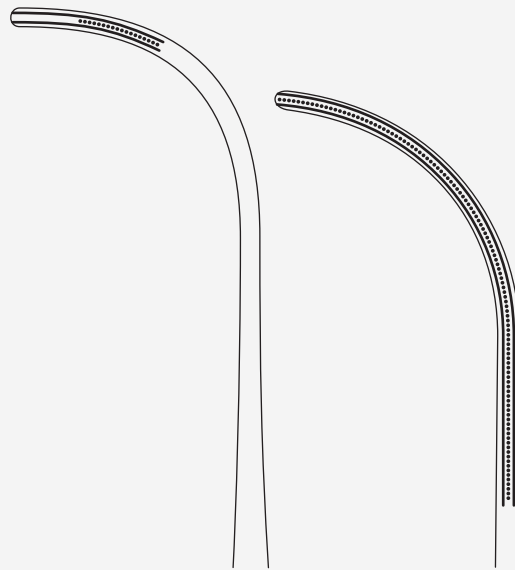

De Bakey-Semb

10-282-24

10-283-24

24 cm - 9 1/2"

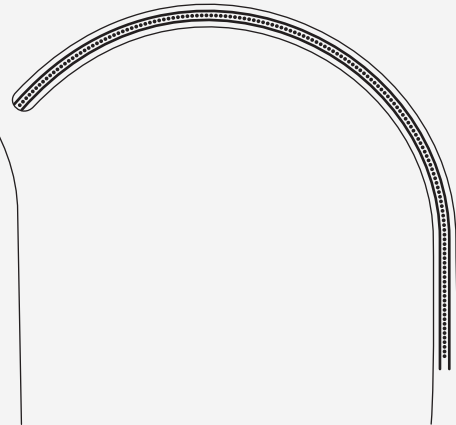
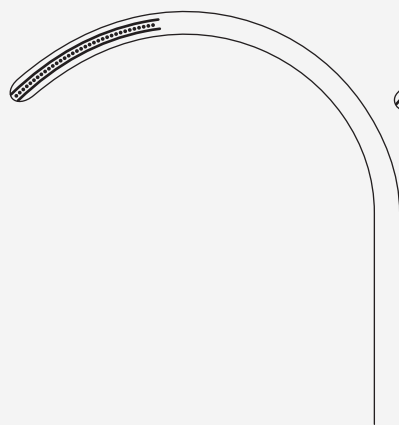

De Bakey

10-284-25

25 cm - 10"

10-285-26

26 cm - 10 1/4"

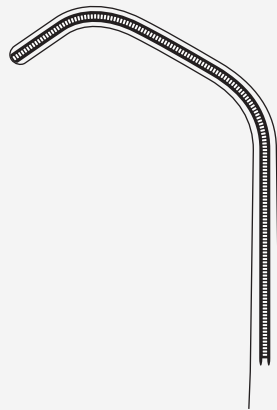

Satinsky-  
De Bakey  
10-286-20  
20.5 cm - 8"

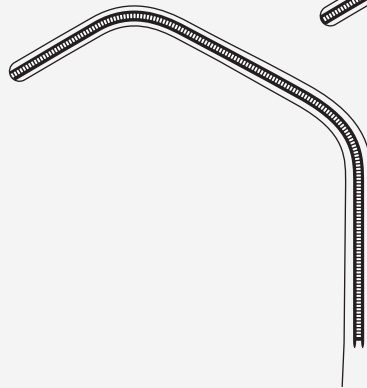

10-287-24  
24 cm - 9 3/4"

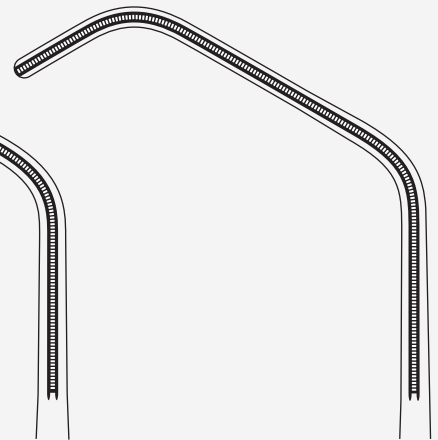

10-288-25  
25 cm - 10"

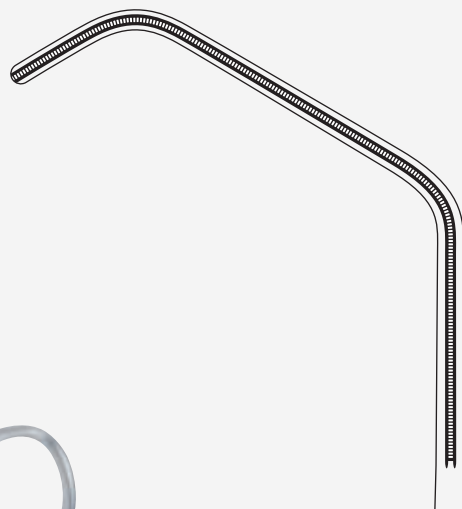

10-289-26  
26.5 cm - 10 1/2"

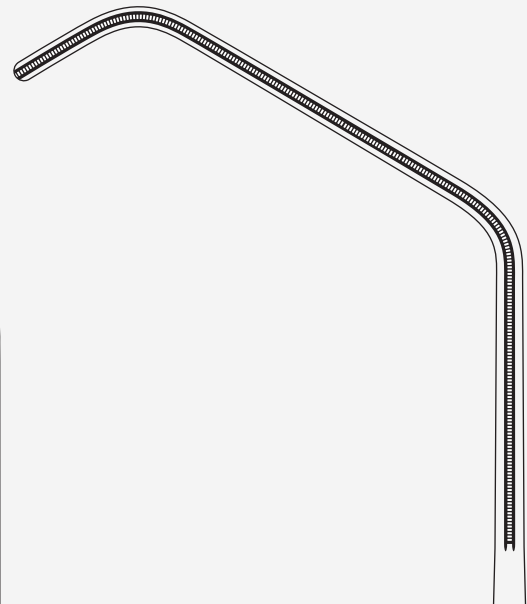

10-290-27  
27.5 cm - 10 3/4"





Lees

10-291-23

23 cm - 9"

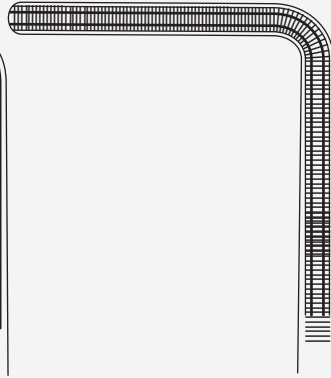
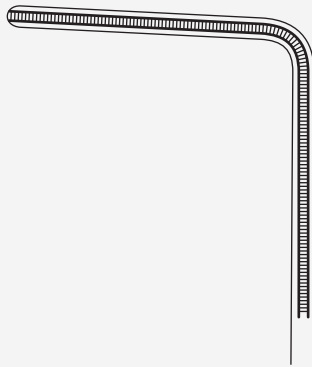

10-292-25

25 cm - 9 3/4"

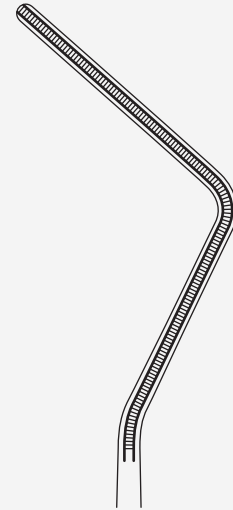

10-293-25

25 cm - 9 3/4"

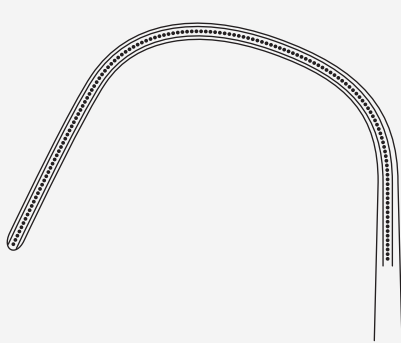

Lambert-Kay

10-294-20

20 cm - 8"

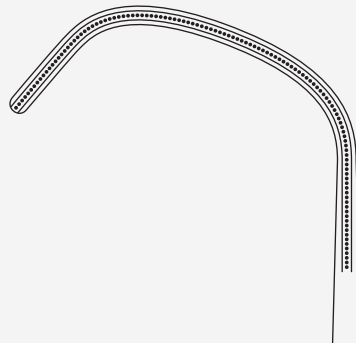

10-295-00

20 cm - 8"

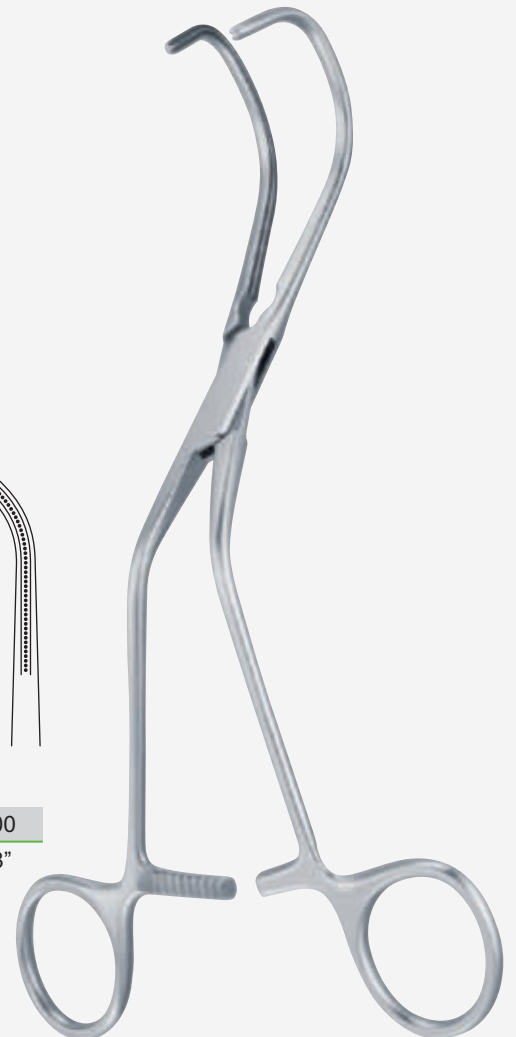

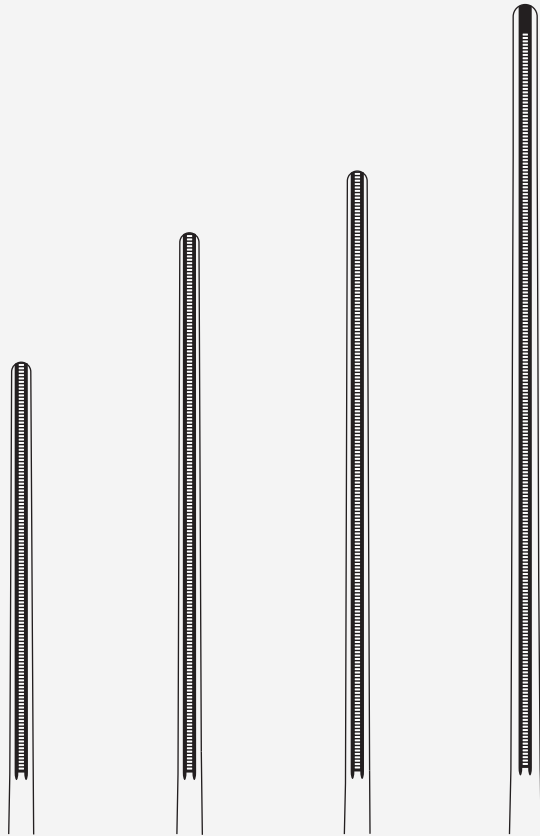

De Bakey

10-296-21	10-297-23	10-298-27	10-299-31
21.5 cm - 8 1/2"	23 cm - 9"	27 cm - 10 3/4"	31.5 cm - 12 1/2"

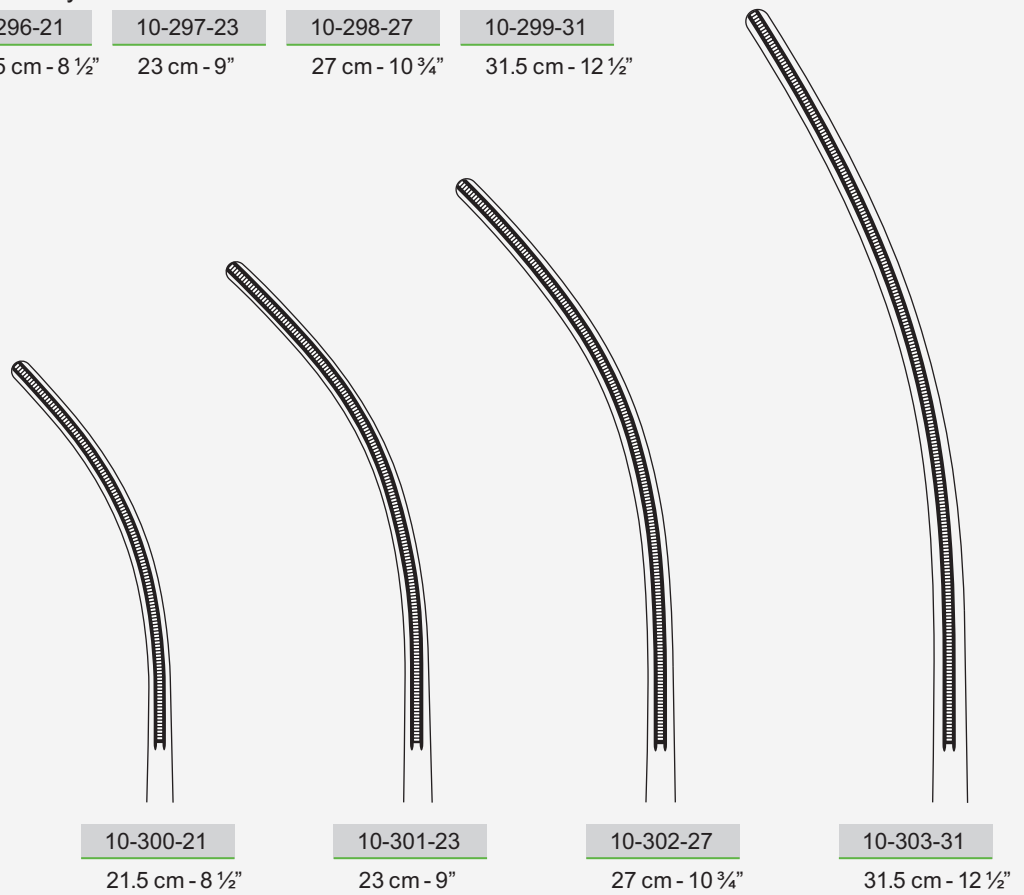

10-300-21	10-301-23	10-302-27	10-303-31
21.5 cm - 8 1/2"	23 cm - 9"	27 cm - 10 3/4"	31.5 cm - 12 1/2"

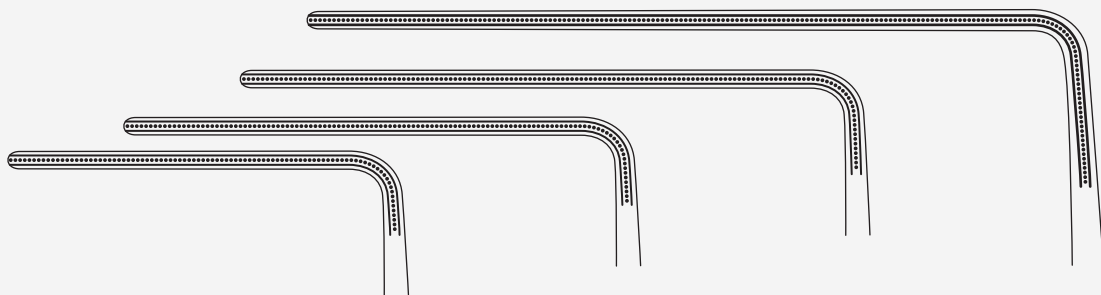

**De Bakey**

10-304-18

18 cm - 7"

10-305-19

19 cm - 7 1/2"

10-306-23

23 cm - 9"

10-307-27

27 cm - 10 3/4"

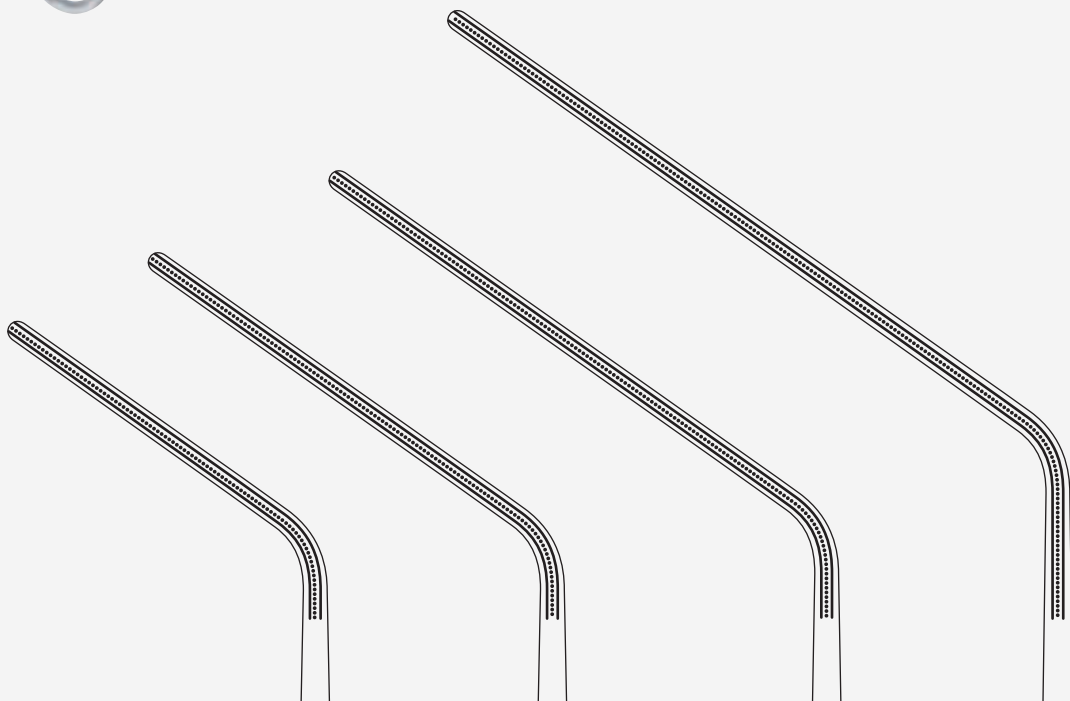

10-308-20

20 cm - 8"

10-309-21

21 cm - 8 1/4"

10-310-25

25 cm - 9 3/4"

10-311-30

30 cm - 12"

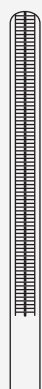

Dardik

10-312-17

0°

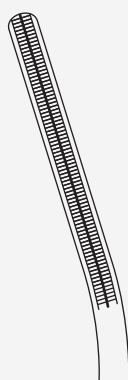

10-313-17

15°

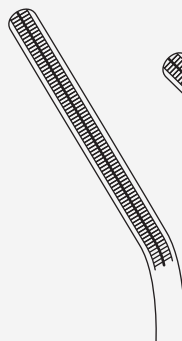

10-314-17

30°

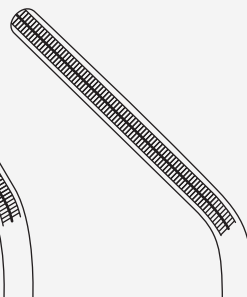

10-315-17

45°

17 cm - 6 3/4"



10-316-16

16 cm - 6 1/4"

90°

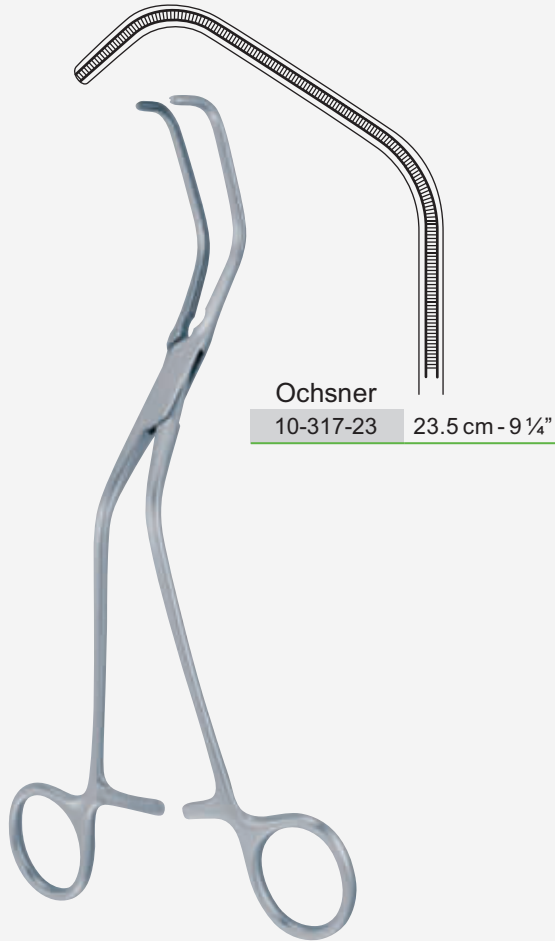

Ochsner  
10-317-23 23.5 cm - 9 ¼"

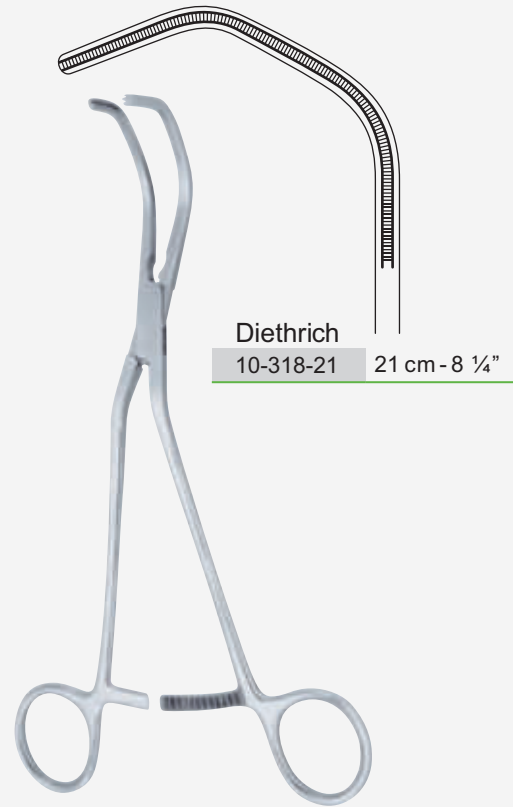

Diethrich  
10-318-21 21 cm - 8 ¼"

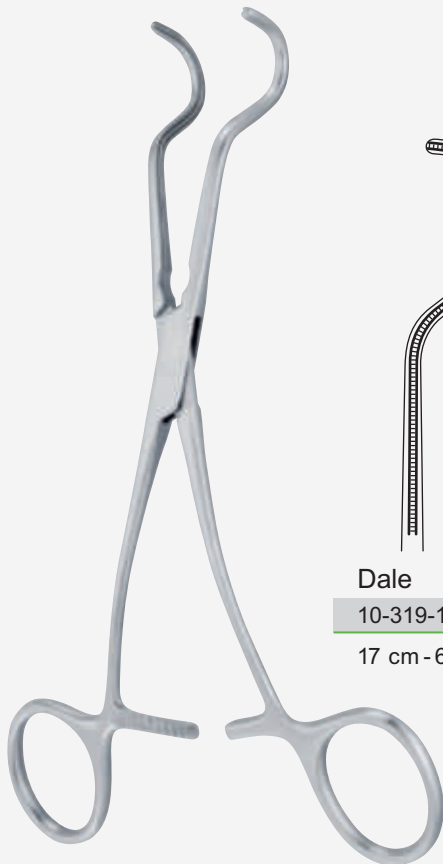

Dale  
10-319-17  
17 cm - 6 ¾"

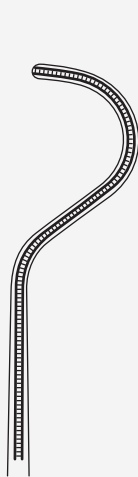

10-320-17  
17.5 cm - 7"

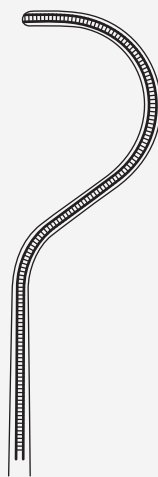

10-321-18  
18.5 cm - 7 ¼"

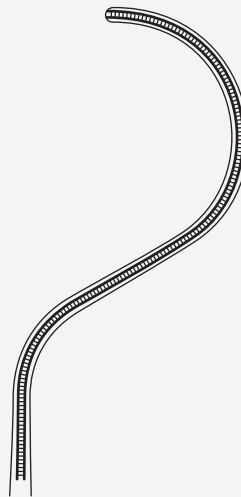

10-322-18  
18.5 cm - 7 ¼"

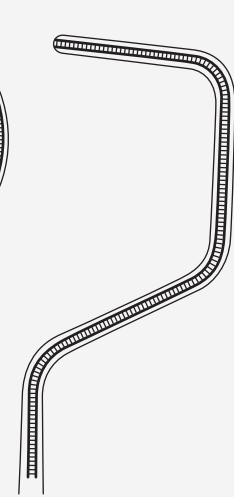

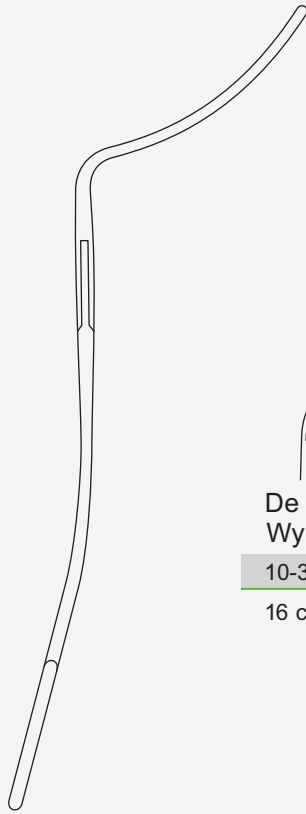
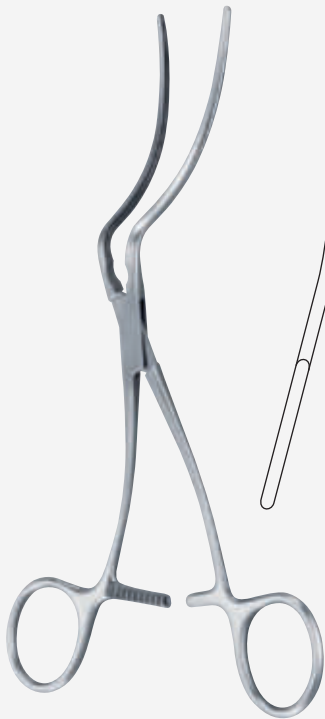

De Bakey-  
Wylie

10-323-16

16 cm - 6 1/4"

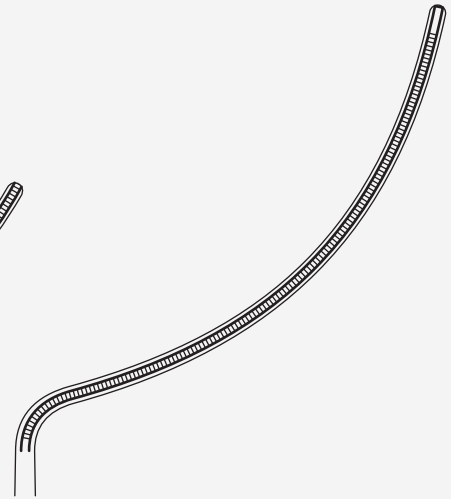
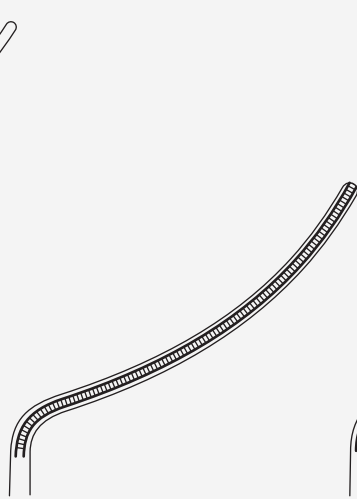

10-324-18

18 cm - 7"

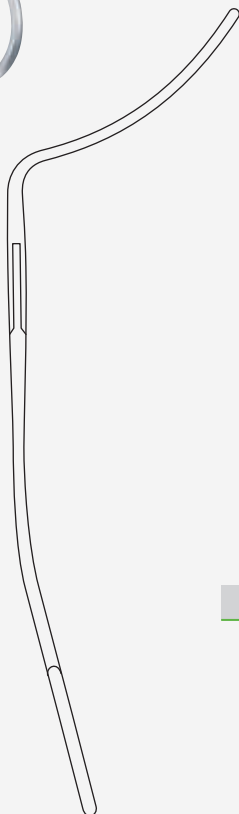

De Bakey-Wylie

10-325-17

17 cm - 6 3/4"

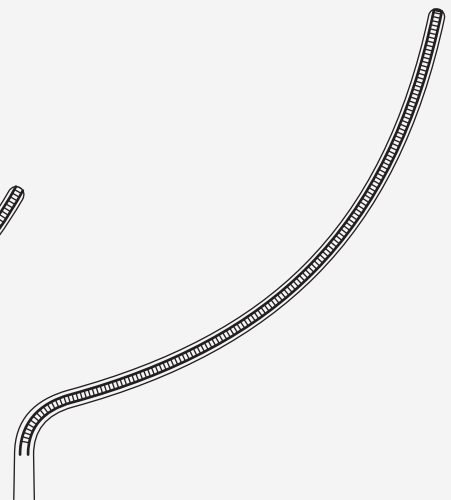
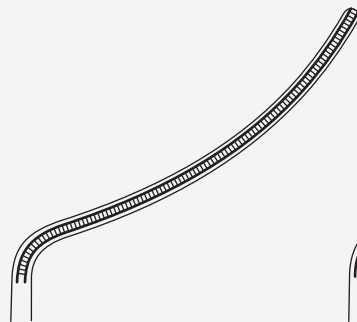

10-326-20

20 mm - 8"



Gregory

10-327-14  
14 cm - 5 1/2"

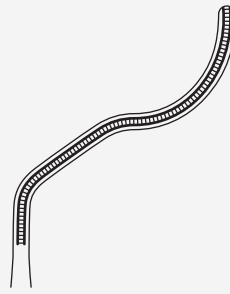

10-328-16  
16 cm - 6 1/4"

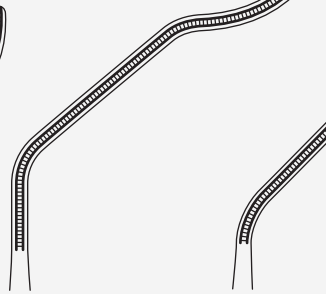

10-329-18  
18 cm - 7"

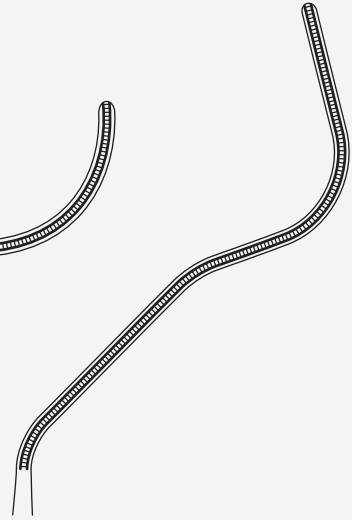

Javid

10-330-16  
16 cm - 6 1/4"

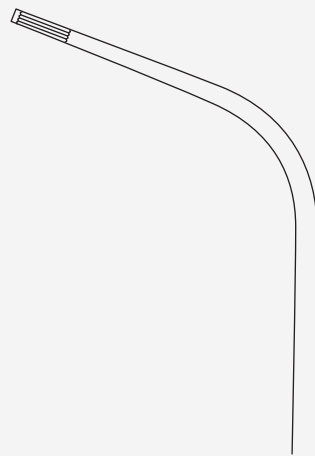

10-331-19  
19 cm - 7 1/2"

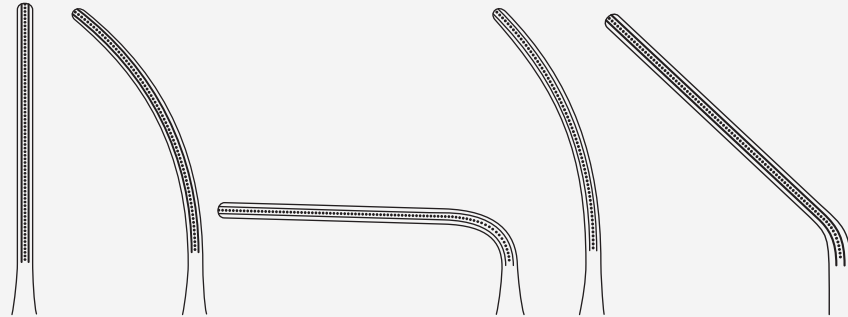

**De Bakey**

10-332-12

12 cm - 4 3/4"

10-333-11

11 cm - 4 1/4"

10-334-10

10 cm - 4"

10-335-12

12 cm - 4 3/4"

10-336-13

13 cm - 5"

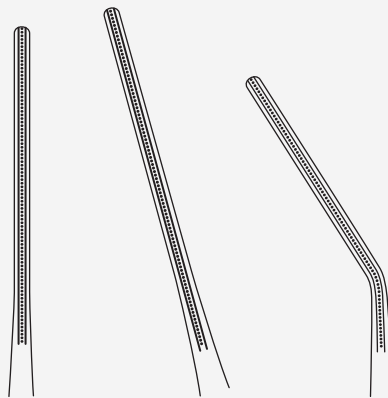

**De Bakey**

10-337-17

17 cm - 6 3/4"

10-338-17

17 cm - 6 3/4"

10-339-16

16 cm - 6 1/4"

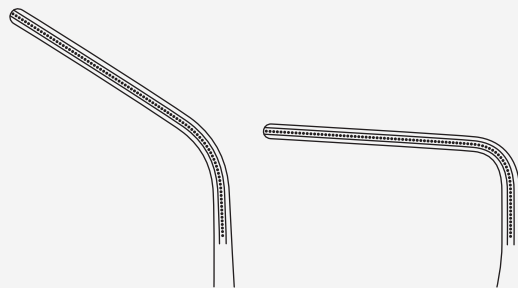

10-340-15

15 cm - 6"

10-341-14

14 cm - 5 1/2"





Glover  
10-342-20  
20.5 cm - 8"



10-343-22  
22 cm - 8 ¾"



10-344-26  
26 cm - 10 ¼"

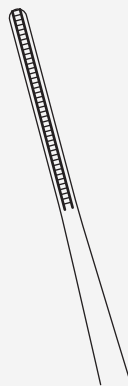

Glover  
10-345-20  
20.5 cm - 8"  
angled on flat  
abgewinkelt  
angulado  
coudé sur le plat  
angolato

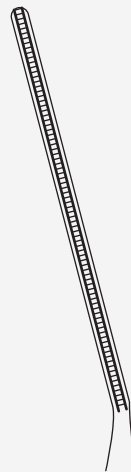

10-346-22  
22 cm - 8 ¾"  
angled on flat  
abgewinkelt  
angulado  
coudé sur le plat  
angolato

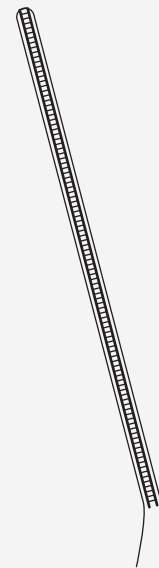

10-347-26  
26 cm - 10 ¼"  
angled on flat  
abgewinkelt  
angulado  
coudé sur le plat  
angolato

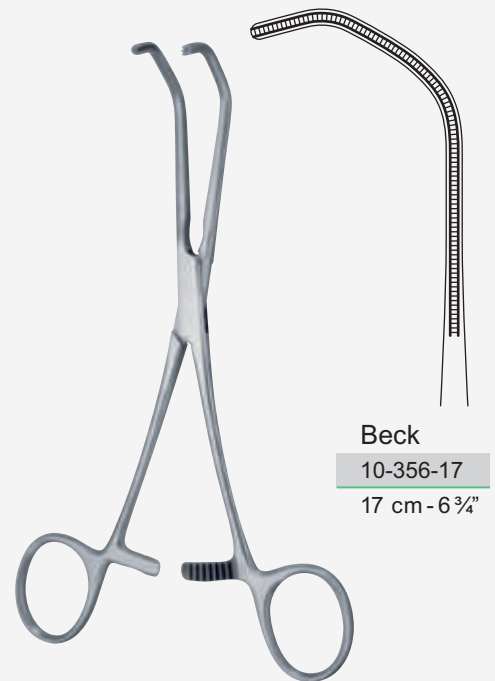
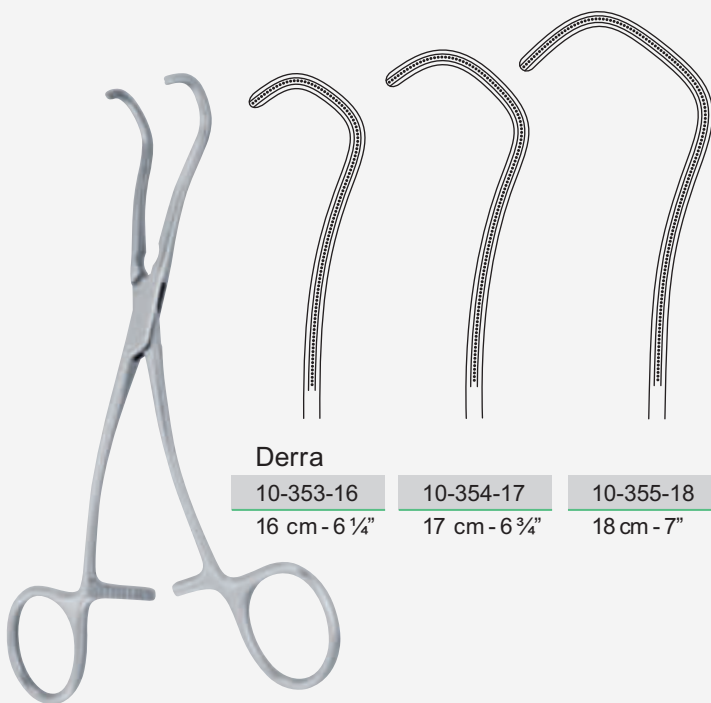
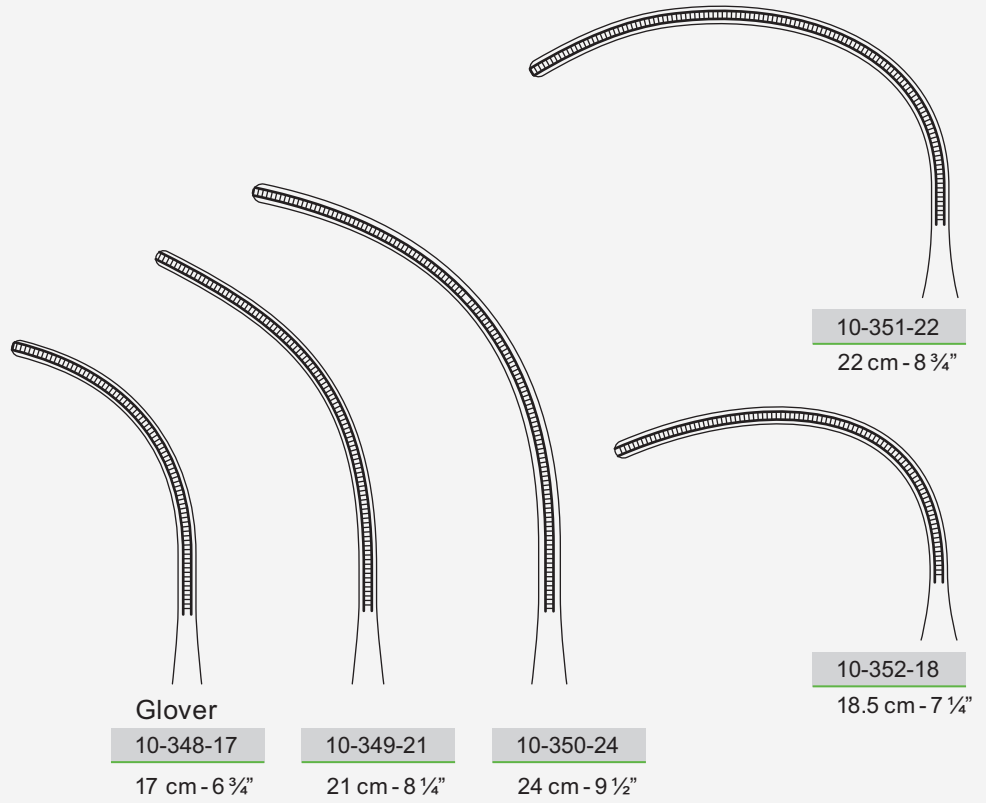



curved  
gebogen  
curva  
courbe  
curve

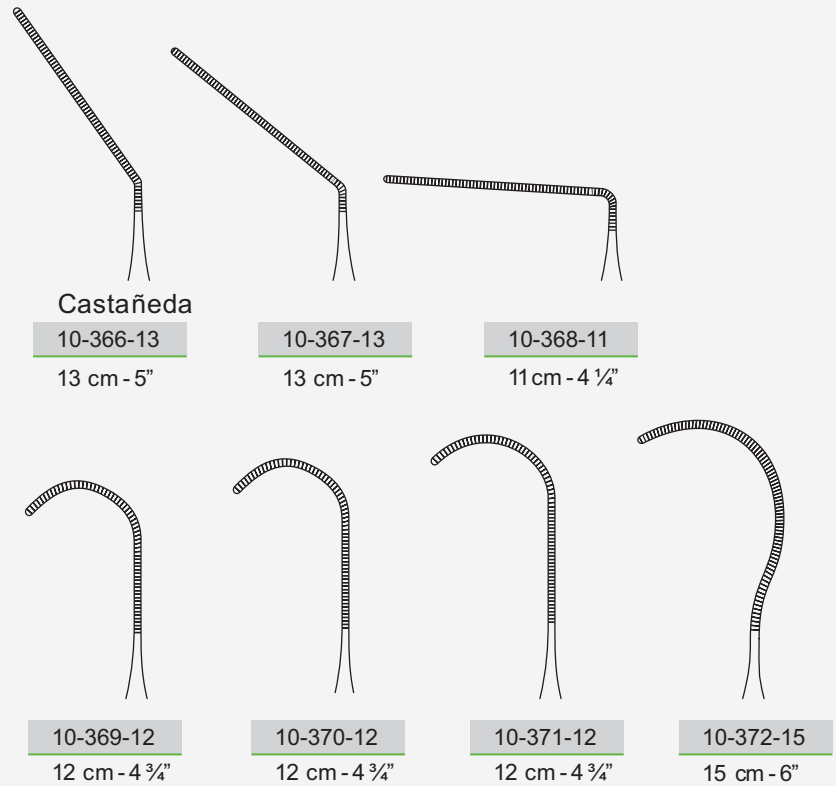
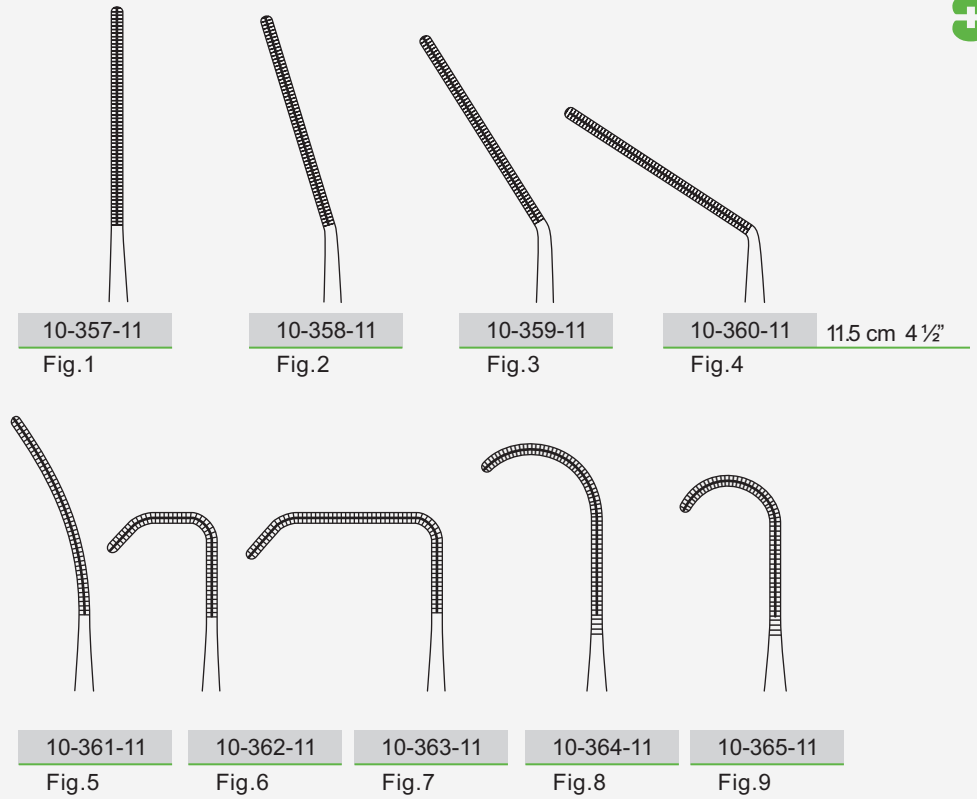

Neonatal and children's clamps, extra delicate patterns  
 Neonatal- u. Kinderklemmen, extra feine Modelle  
 Pinzas para recién nacidos y niños, modelos muy finos  
 Pinces pour nouveaux-nés et enfants, modèles très fins  
 Pinze neonatali e per bambini, i modelli delicati aggiuntivi

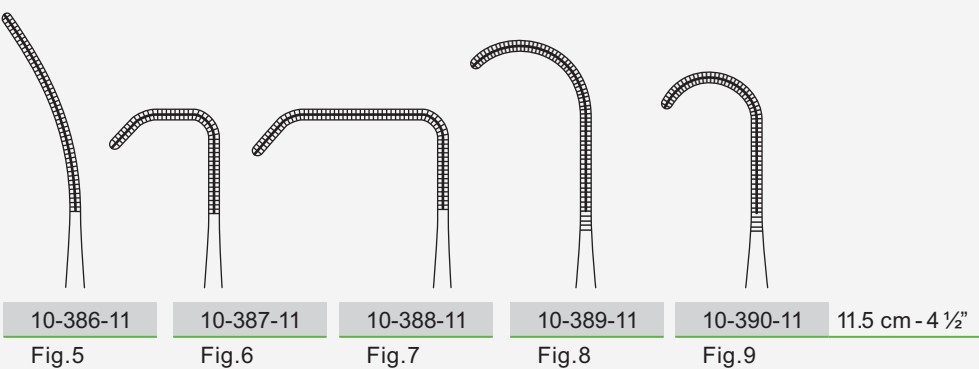
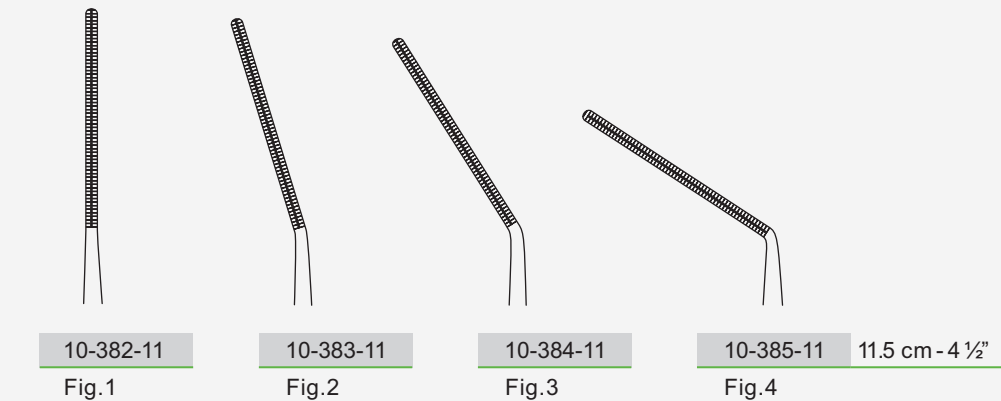
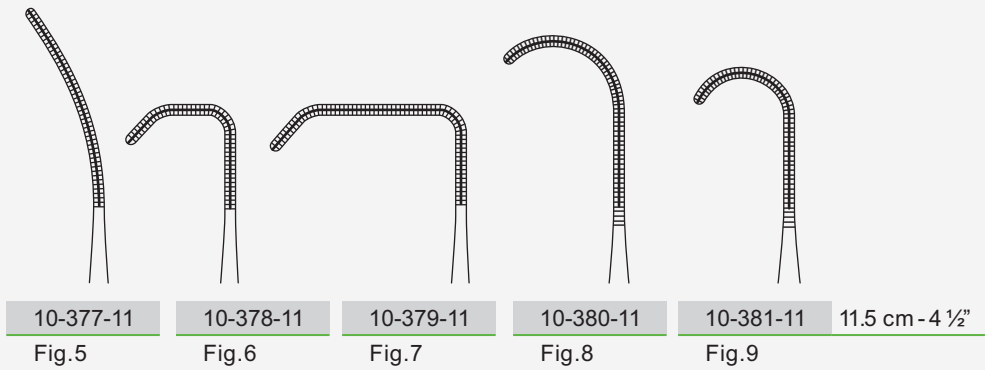
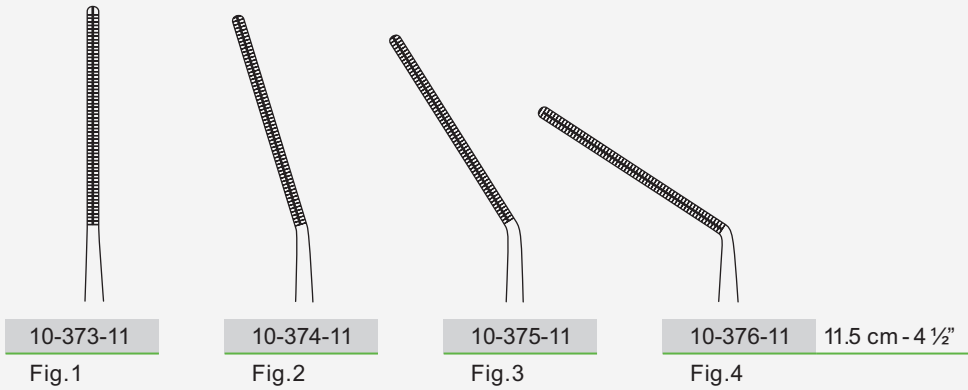



Cooley

10-391-12

straight  
gerade  
recta  
droit  
retta

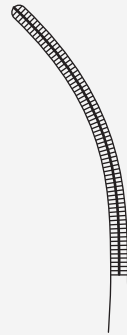

10-392-22

curved  
gebogen  
curva  
courbe  
curva



10-393-22 12 cm - 4 3/4"

S-curved  
S-förmiggebogen  
curva en S  
courbe en S  
curva a forma S



Cooley

10-394-12

sidewards angled  
seitlich gewinkelt  
angulado al lado  
coudé vers la coté  
angolata lateralmente

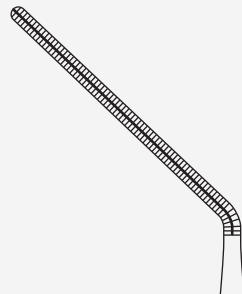

10-396-12

angled on flat  
abgewinkelt  
angulado  
coudé sur le plat  
angolato



10-397-12 12 cm - 4 3/4"

90° angled on flat  
90° abgewinkelt  
90° angulado  
90° coudé sur le plat  
90° angolato

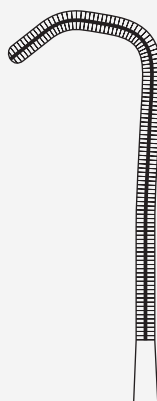

Cooley

10-398-17 17 cm - 6 3/4"

sidewards angled  
seitlich abgewinkelt  
angulado al lado  
coudé vers la coté  
angolata lateralmente

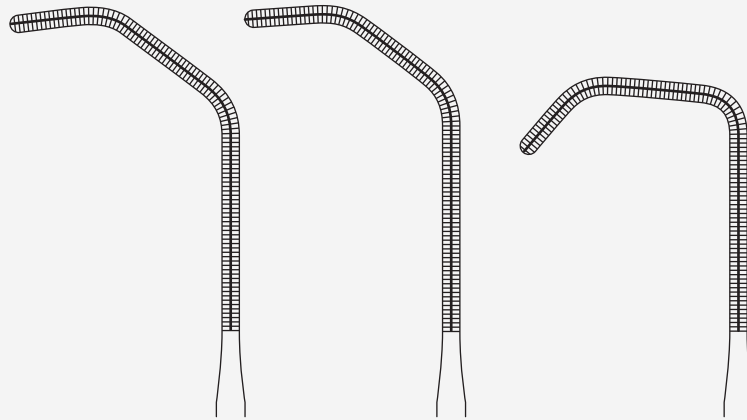

Cooley

10-399-17

17.5 cm - 7"

10-400-17

17.5 cm - 7"

10-401-16

16.5 cm - 6 1/2"

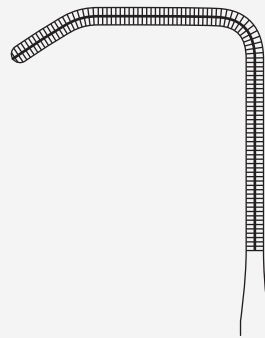

10-402-16

16.5 cm - 6 1/2"

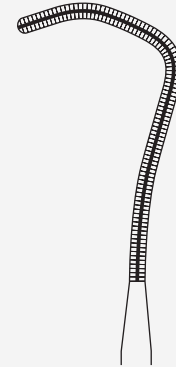

10-403-17

17 cm - 6 3/4"

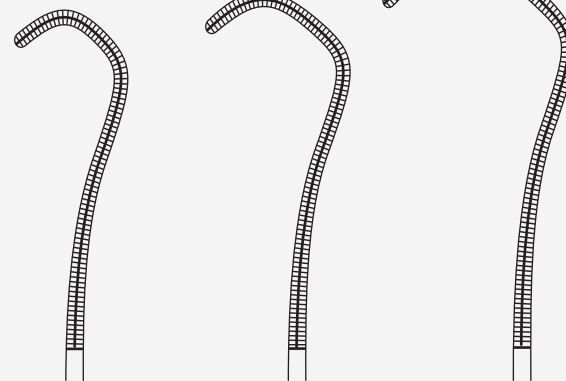

Cooley-Derra

10-404-16

16.5 cm - 6 1/2"

10-405-17

17 cm - 6 3/4"

10-406-17

17.5 cm - 7"



Cooley-Beck

10-407-15

15 cm - 6"

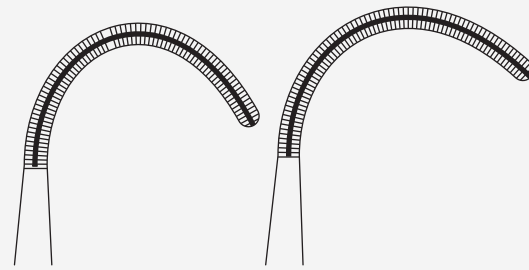

10-408-15

15.5 cm - 6"



Cooley

10-409-15

15 cm - 6"

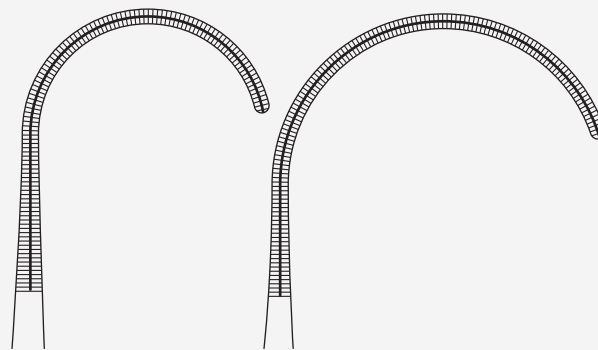

10-410-16

16 cm - 6 1/4"



Cooley

10-411-21

21 cm - 8 1/4"

sidewards angled on flat  
 seitwärts abgewinkelt  
 angulado al lado  
 coudé vers la coté  
 angolata lateralmente

10-412-25

25 cm - 9 3/4"

sidewards angled on flat  
 seitwärts abgewinkelt  
 angulado al lado  
 coudé vers la coté  
 angolata lateralmente



Cooley

10-413-18

18 cm - 7"

straight  
 gerade  
 recta  
 droite  
 retta

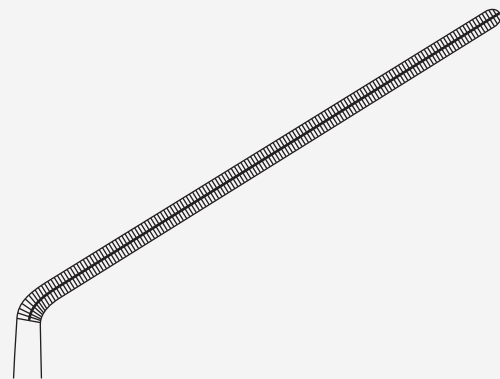

10-414-18

18.5 cm - 7 1/4"

angled on flat  
 abgewinkelt  
 angulado  
 coudé sur le plat  
 angolata





Cooley-  
Tangential

10-415-19

19.5 cm - 7 3/4"

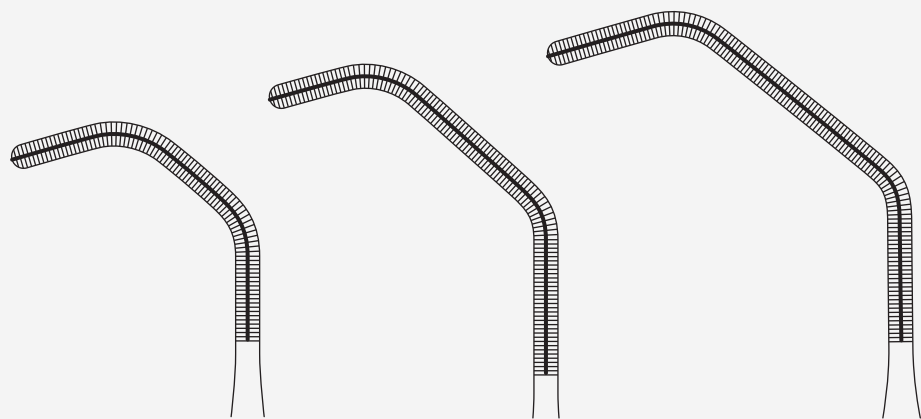

10-416-25

25.5 cm - 10"

10-417-26

26 cm - 10 1/4"



10-418-26

26.5 cm - 10 1/2"

10-419-27

27 cm - 10 3/4"

Multi-purpose clamps, pediatric, graduated  
 Mehrzweckklemmen, pädiatrisch, graduert  
 Pinzas de uso vario, pediátricas, graduadas  
 Pincas polyvalentes, pédiatriques, graduées  
 Pinze multiuso, pediatrica, si è laureato

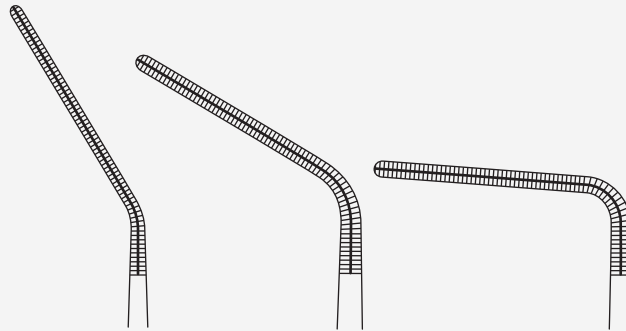

Cooley

10-420-16

16.5 cm - 6 1/2"  
 25°

10-421-16

16 cm - 6 1/4"  
 45°

10-422-14

14.5 cm - 5 3/4"  
 90°



Cooley  
 Patent Ductus Clamp

10-423-16

10-423-17

10-423-20

10-423-21

10-423-23

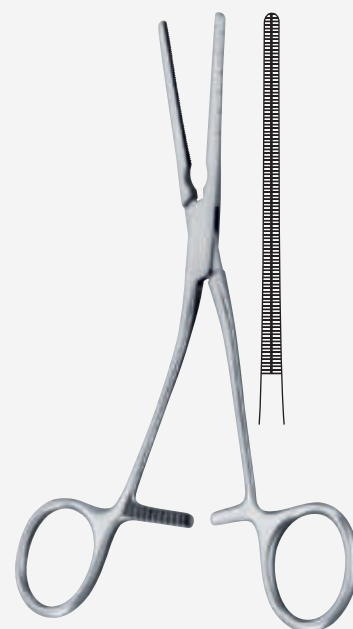

10-424-16 16 cm - 6 1/4"

10-424-17 17 cm - 6 3/4"

10-424-20 20 cm - 8"

10-424-21 21 cm - 8 1/4"

10-424-23 23 cm - 9"

angled on flat, graduated  
 abgewinkelt, graduert  
 angulada, graduada  
 coudée sur le plat, graduée  
 angolata, graduata

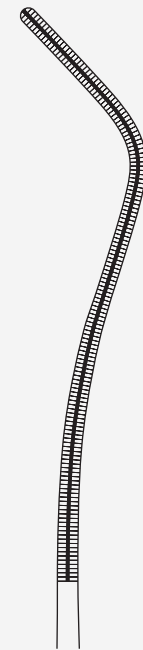

Cooley  
10-425-20  
20 cm - 8"

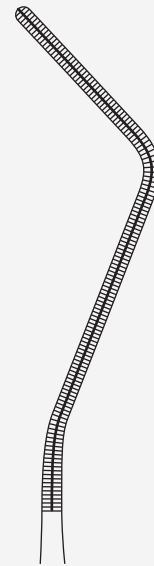

10-426-19  
19.5 cm - 7 3/4"

Multi-purpose clamps  
Mehrzweckklemmen  
Pinzas clamps para usos varios  
Pinces clamps polyvalentes  
Pinze multiuso

**comed**  
operate better with us

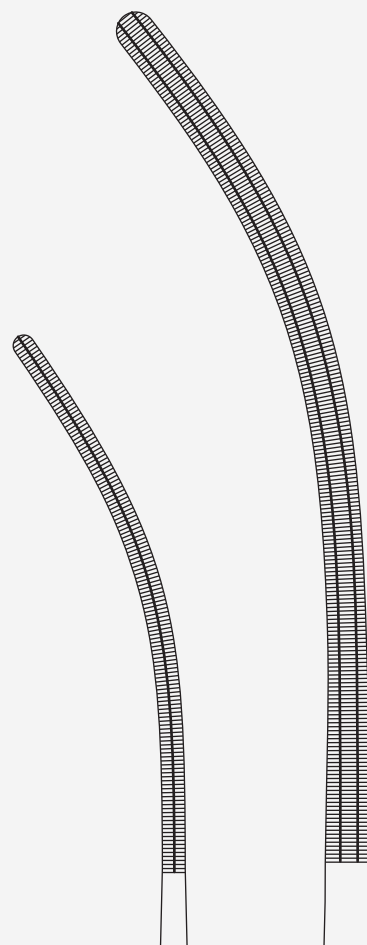
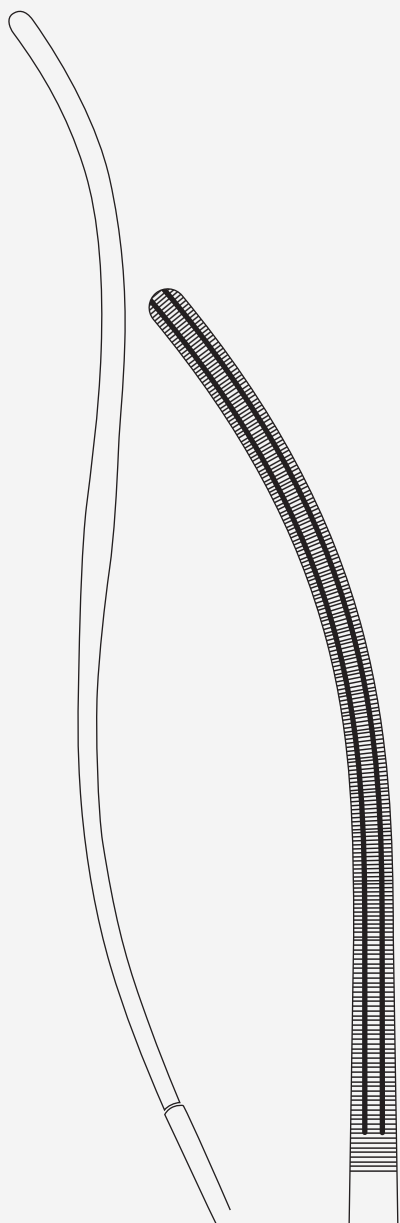

Cooley

10-427-26

26.5 cm - 10 1/2"

10-428-33

33.5 cm - 13 1/4"

Cooley

10-429-31

31.5 cm - 12 1/2"

S-curved  
S-förmiggebogen  
curva en S  
courbe en S  
curva a forma S



De Bakey						
10-430-19	10-431-19	10-432-19	10-433-19	10-434-19	10-435-19	19 cm - 7 1/2"
10-430-35	10-431-35	10-432-35	10-433-35	10-434-35	10-435-35	35 cm - 13 3/4"
0.5 mm Ø	1.0 mm Ø	1.5 mm Ø	2.0 mm Ø	2.5 mm Ø	3.0 mm Ø	
Fig. 1	Fig. 2	Fig. 3	Fig. 4	Fig. 5	Fig. 6	

10-436-19	10-437-19	10-438-19	10-439-19	10-440-19	10-441-19	19 cm - 7 1/2"
10-436-35	10-437-35	10-438-35	10-439-35	10-440-35	10-441-35	35 cm - 13 3/4"
3.5 mm Ø	4.0 mm Ø	4.5 mm Ø	5.0 mm Ø	7.0 mm Ø	9.0 mm Ø	
Fig. 7	Fig. 8	Fig. 9	Fig. 10	Fig. 11	Fig. 12	

malleable  
biegsam  
maleable  
malléable  
flessibile

10-430-00 Set of 12, Fig. 1 to Fig. 12  
19 cm - 7 1/2"



Cooley

10-442-13	10-443-13	10-444-13	10-445-13	13 cm - 5"
0.5 mm Ø	1.0 mm Ø	1.5 mm Ø	2.0 mm Ø	
Fig. 1	Fig. 2	Fig. 3	Fig. 4	

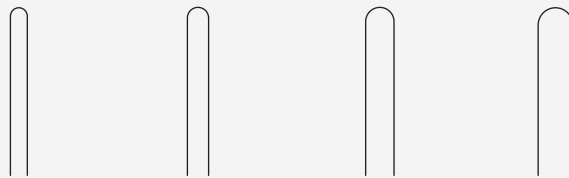

10-446-19	10-447-19	10-448-19	10-449-19	13 cm - 5"
2.5 mm Ø	3.0 mm Ø	4.0 mm Ø	5.0 mm Ø	
Fig. 5	Fig. 6	Fig. 7	Fig. 8	

malleable  
 biegsam  
 maleable  
 malléable  
 flessibile

10-442-00	Set of 8, Fig. 1 to Fig. 8
13 cm - 5"	

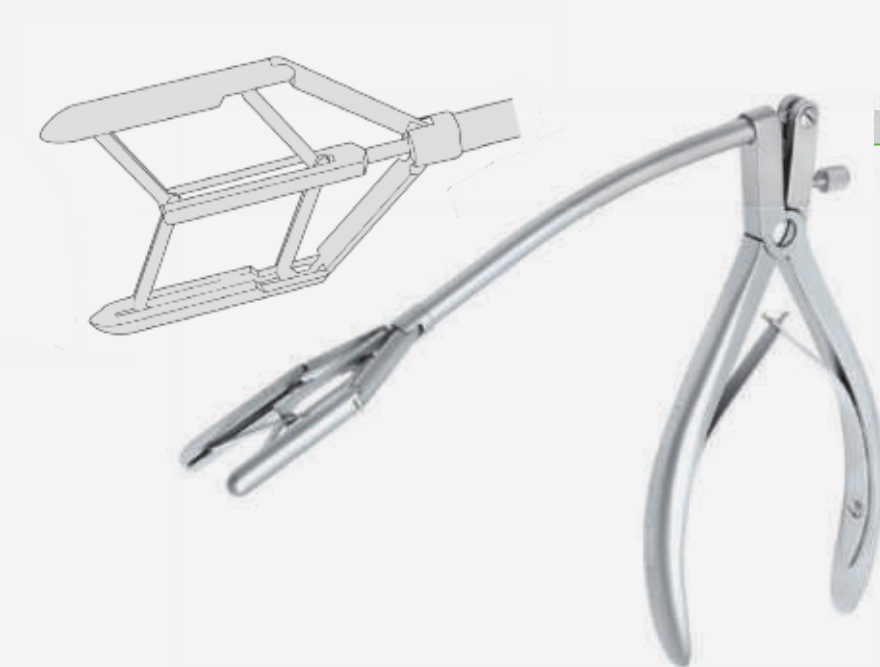

**Tubbs**

10-450-00

for adults, blade opening from 8 mm – 42mm  
für Erwachsene, Spreizweite 8mm – 42mm  
para adultos, abertura de 8 mm – 42 mm  
pour adultes, écartement de 8 mm – 42 mm  
per adulti, apertura da 8 mm – 42 mm

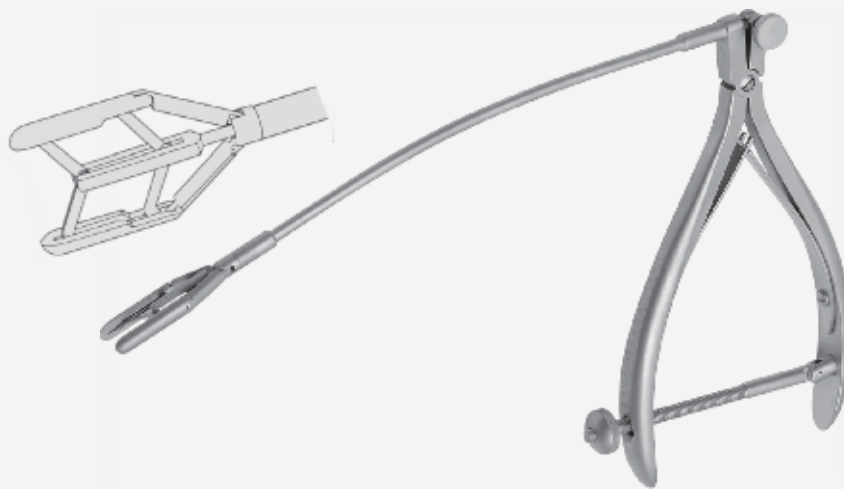

#### Cooley

10-451-00

for children, blade opening from 6 mm – 15mm  
für Kinder, Spreizweite 6 mm – 15mm  
para niños, apertura de 6 mm – 15mm  
pour enfants, écartement de 6 mm – 15mm  
per bambini, apertura da 6 mm – 15mm





Dressings  
Verband  
Vendajes  
Pansements  
Bendaggi



Engel

11-300-14

14 cm - 5 1/2"



Bergmann

11-301-18

18 cm - 7"

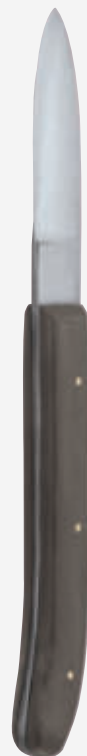

Hopkins

11-302-20

20 cm - 8"



Esmarch

11-303-18

18 cm - 7"



Stille

11-304-23 23 cm - 9"

11-304-26 26 cm - 10 1/4"

11-304-37 37 cm - 14 1/2"



**Wolf**  
11-305-18  
18 cm - 7"

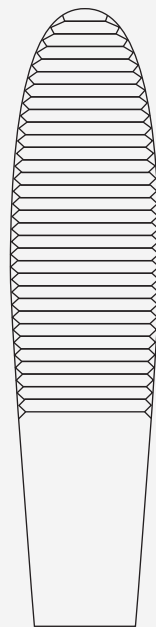

**USA Modell**  
11-307-23  
23 cm - 9"



**USA Modell**  
11-307-23  
23 cm - 9"



Beeson  
11-308-30  
30 cm - 12"



Henning  
11-309-28  
28 cm - 11"  
Grooved handle



Bone surgery  
Knochenchirurgie  
Cirugía ósea  
Chirurgie osseuse  
Chirurgia ossea

comed  
operate better with us

12

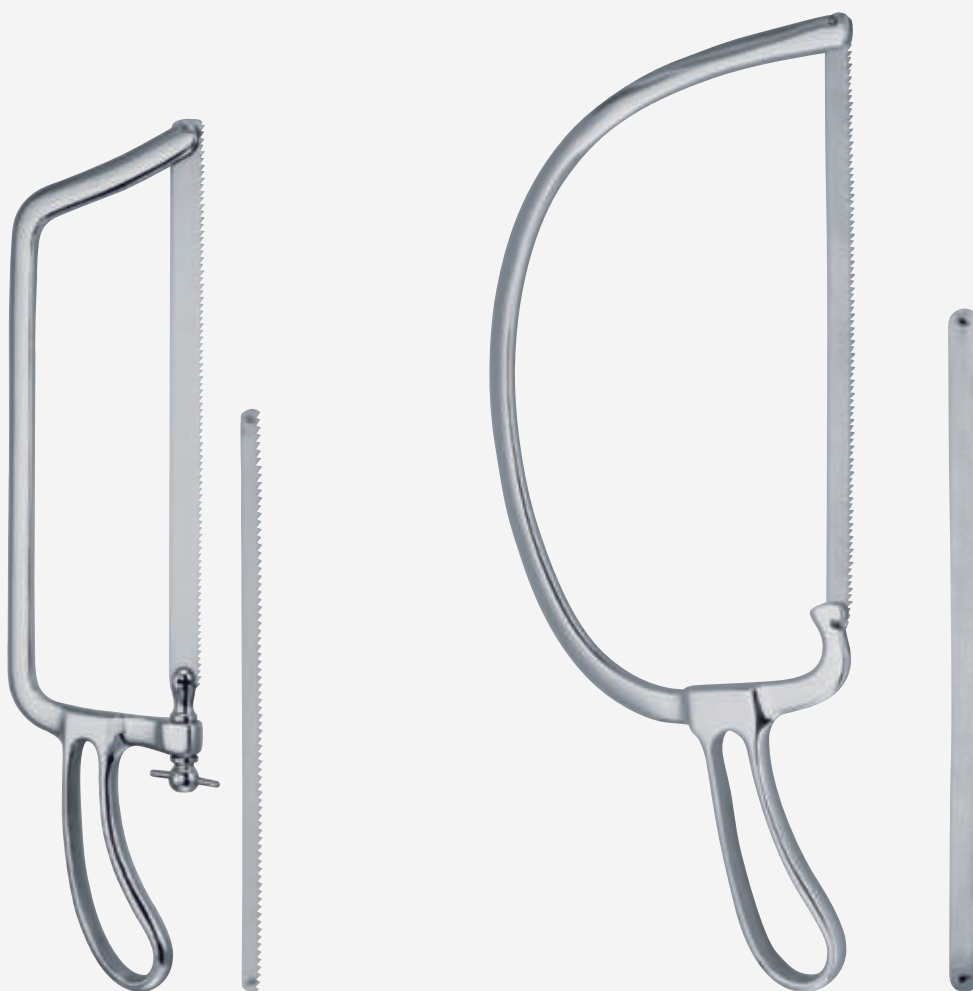

**Charriere**

12-500-35	12-501-12	1.2 cm
35 cm - 13 3/4"	12-501-15	1.5 cm

Spare saw blades  
 Ersatzsägeblätter  
 Hojas de cambio  
 Lames de rechange  
 Lame di ricambio

**HelferichBier**

12-502-39	12-503-03	3 mm
39 cm - 15 1/2"	12-503-05	5 mm
	12-503-07	7 mm

Spare saw blades  
 Ersatzsägeblätter  
 Hojas de cambio  
 Lames de rechange  
 Lame di ricambio



Satterlee

12-504-31

31 cm - 12 ¼"



Langenbeck

12-505-23

23 cm - 9"



Charriere

12-506-27 27 cm - 10 ¾"

12-506-30 30 cm - 12"

12-506-34 34 cm - 13 ½"

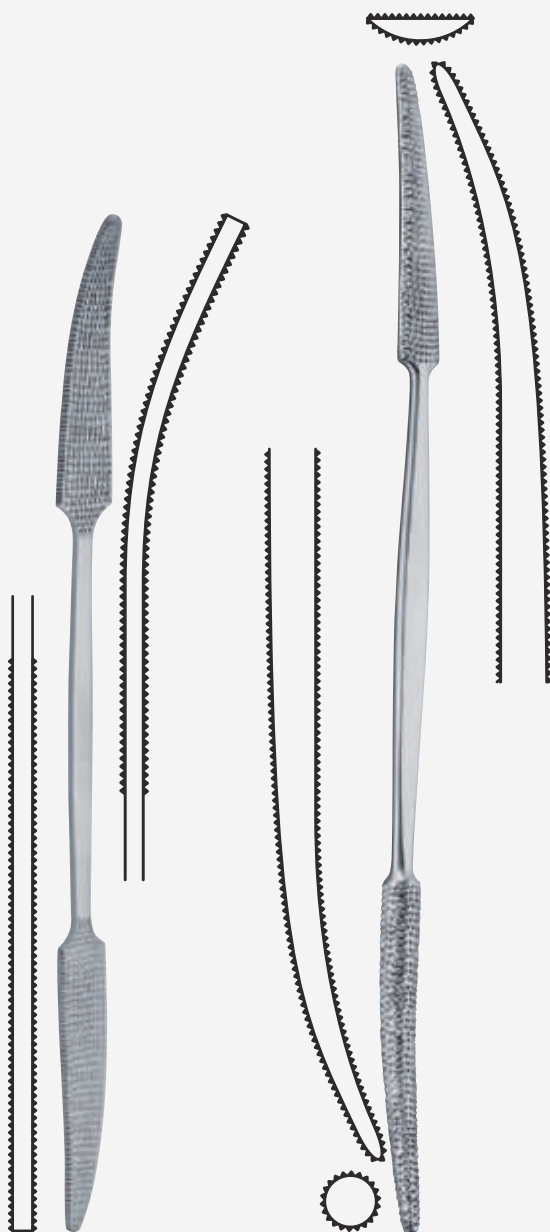

Putti  
 Fig. 1  
 12-507-27  
 27 cm - 10 3/4"

Fig. 2  
 12-508-30  
 30 cm - 12"



Rasp  
 Fig. 1  
 12-509-28  
 28 cm - 11"

semi circular  
 halbrund  
 semi-redonda  
 semi-ronde  
 semi-rotonda



Fig. 2  
 12-510-24  
 24.5 cm - 9 3/4"  
 x = 13 mm

semi circular  
 halbrund  
 semi-redonda  
 semi-ronde  
 semi-rotonda



Fig. 3  
 12-511-22  
 22 cm - 8 3/4"  
 x = 20 mm

flat  
 flach  
 plana  
 plate  
 piatta





**Doyen**

12-512-12 2.5 cmØ – 120 g  
12-512-18 3.0 cmØ – 180 g  
12-512-26 3.5 cmØ – 260 g  
19.5 cm - 7 ¾"



**Collin**

12-513-20  
20 cm - 8"  
30 mmØ – 220 g

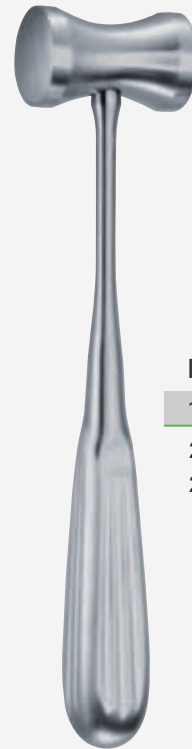

**Hajek**

12-514-21  
21.5 cm - 8 ½"  
27 mmØ – 140 g

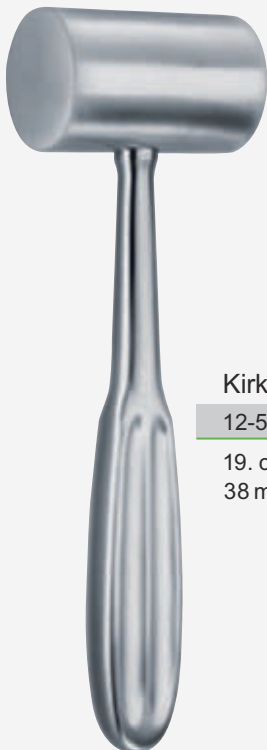

**Kirk**

12-515-19  
19. cm - 7 ½"  
38 mmØ – 750 g



**Partsch**

12-516-18  
18 cm - 7"  
22 mmØ – 200 g



**Lucae**

12-517-19 19 mmØ – 230 g  
12-517-25 25 mmØ – 260 g  
19 cm - 7 ½"



**Williger**

12-518-16

16.5 cm - 6 1/2"

20 mm Ø - 140 g



**Mead**

12-519-17

17 cm - 6 3/4"

26 mmØ - 320 g

Steel solid, with plastic faces

Stahl massiv, mit Kunststoffbacken

Acero solido, con placas en plastica

Acier solid, avec plaques en plastique

Acciaio massiccio, con punte di plastica

12-520-17

Spare faces, 1 pair

Ersatzbacken, 1 Paar

Placas de cambio, 1 par

Plaques de rechange, 1 paire

Punte di ricambio, 1 paio



**Bergmann**

12-523-24

24.5 cm - 9 3/4"

45 mmØ - 300 g



**Ombredanne**

12-521-24

24 cm - 9 1/2"

40 mmØ - 550 g

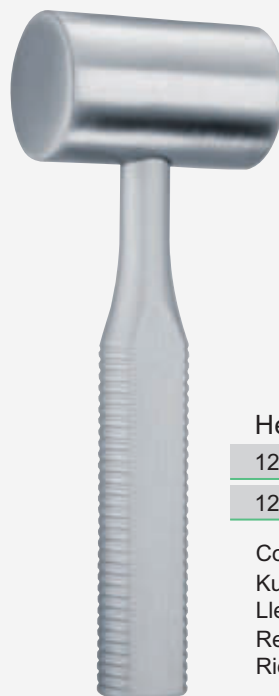

**Heath**

12-522-18 40 mmØ - 700 g 18 cm - 7"

12-522-20 45 mmØ - 1000 g 20 cm - 8"

Copper filled head

Kupferfüllung

Llenado de cobre

Rempli de cuivre

Riempito di rame



**Mead Modified**

12-524-19

19 cm - 7 1/2"

250 mmØ - 205 g

Solid steel, with plastic faces

Massiver Stahl, mit Kunststoffbacken

Acero solido, con placas en plastica

Acier solid, avec plaques en plastique

Acciaio massiccio, con punte di plastica

12-525-19

Spare faces, 1 pair

Ersatzbacken, 1 Paar

Placas de cambio, 1 par

Plaques de rechange, 1 paire

Punte di ricambio, 1 paio



**Cottle**

12-526-18

18.5 cm - 7 1/4"

30 mmØ - 240 g

1 side flat/1 side convex

1 Seite flach / 1 Seite convex

1 lado plano / 1 lado convexo

1 coté plat/ 1 coté convex

1 lato piatto/ 1 lato convesso



**Williger**

12-527-28 28 mmØ - 340 g

12-527-30 30 mm Ø - 400 g

24 cm - 9 1/2"

lead filled

bleigefüllt

llenado con plomo

rempli de plomb

riempito di piombo

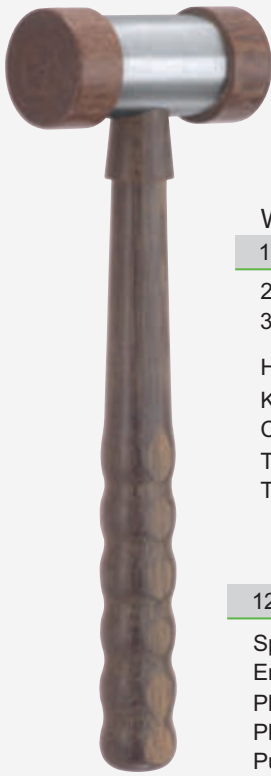

Waze

12-528-22

22.5 cm - 8 ¾"  
37 mmØ - 370 g

Head solid steel, with Ferrozell faces  
Kopf massiver Stahl, mit Ferrozellbacken  
Cabeza acero solido, con placas en Ferrozell  
Tête acier solid, avec plaques en Ferrozell  
Testa acciaio massiccio, con punte di Ferrozell

12-529-22

Spare faces, 1 pair  
Ersatzbacken, 1 Paar  
Placas de cambio, 1 par  
Plaques de rechange, 1 paire  
Punte di ricambio, 1 paio

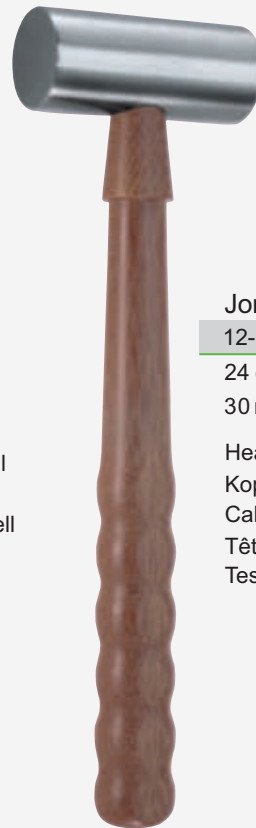

Jonathan

12-530-24

24 cm - 9 ½"  
30 mmØ - 480 g

Head solid steel, Ferrozell handle  
Kopf massiver Stahl, mit Ferrozellstiel  
Cabeza acero solido, con mango en Ferrozell  
Tête acier solid, manche en matière Ferrozell  
Testa acciaio massiccio, con manico di Ferrozell



Jonathan Modified

12-531-26

42 mmØ - 250 g

Ferrozell, without lead  
Ferrozell, ohne Blei  
Ferrozell, sin plomo  
Ferrozell, sans plomb  
Ferrozell, senza piombo

12-532-26 26 cm - 10 ¼"

42 mmØ - 400 g

Plastic, lead filled  
Kunststoff, bleigefüllt  
Plastico, llenado con plomo  
Matière plastique, rempli de plomb  
Plastica, riempito di piombo



Darson

12-533-26

26.5 cm - 10 ½"  
30 mmØ - 450 g

12-534-26

26.5 cm - 10 ½"  
50 mmØ - 900 g



12-535-18  
18.5 cm - 7 1/4"  
Handle Only

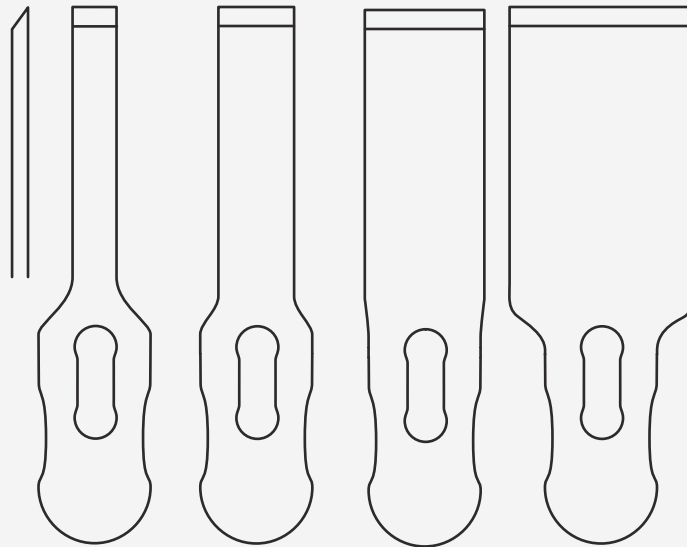

Arrow

12-536-08	12-537-08	12-538-08	12-539-08	8.5 cm - 3 1/4"
5 mm	10 mm	16 mm	25 mm	

Chisel blades, interchangeable  
Meißelklingen, auswechselbar  
Hojas de cincel, intercambiables  
Lames ciseaux-burin, interchangeables  
Lame, intercambiabili



12-540-09  
9 cm - 3 1/2"  
Key  
Spannschlüssel  
Llave  
Clé  
Chiave

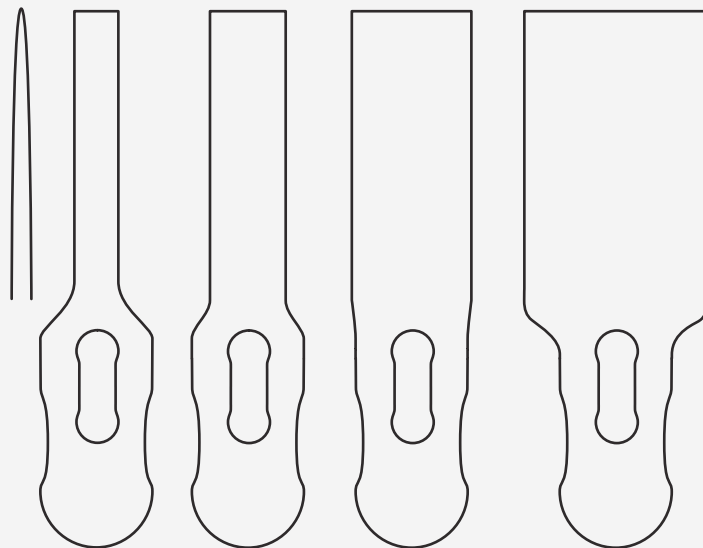

12-541-08	12-542-08	12-543-08	12-544-08	8.5 cm - 3 1/4"
5 mm	10 mm	16 mm	25 mm	

Osteotome blades, interchangeable  
Osteotomklingen, auswechselbar  
Hojas de osteótomo, intercambiables  
Lames d'osteotomos interchangeables  
Lame per osteotomia, intercambiabili

12-535-00	Complete set consisting:
12-535-18	Handle
12-540-09	Key
	Chisel blades 12-536-08 to 12-539-08
	Osteotome blades 12-541-08 to 12-544-08

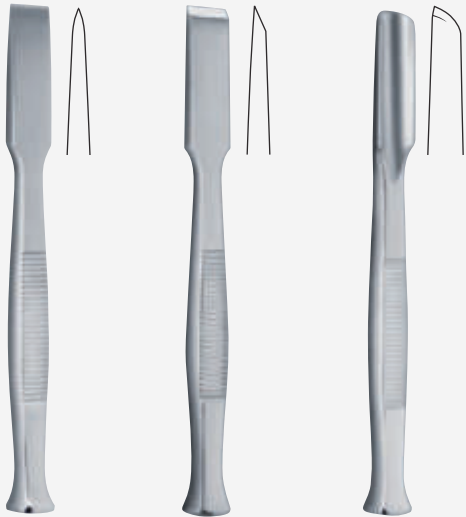

**Mourd**

12-545-08	12-546-08	12-547-08	8 mm
12-545-10	12-546-10	12-547-10	10 mm
12-545-12	12-546-12	12-547-12	12 mm
12-545-14	12-546-14	12-547-14	14 mm
12-545-16	12-546-16	12-547-16	16 mm
13.5 cm - 5 1/4"	13.5 cm - 5 1/4"	13.5 cm - 5 1/4"	



**Lucas**

12-548-03	12-548-07	3 mm
12-548-04	12-548-08	4 mm
12-548-05	12-548-09	5 mm
12-548-06	12-548-10	6 mm

16 cm - 6 1/4"  
 Chisel  
 Flachmeißel  
 Cincel  
 Ciseau burin  
 Scalpello

16 cm - 6 1/4"  
 Gouge  
 Hohlmeißel  
 Gubia  
 Gouge  
 Sgorbi



**Partsch**

12-549-02	12-550-02	12-551-02	2 mm
12-549-03	12-550-03	12-551-03	3 mm
12-549-04	12-550-04	12-551-04	4 mm
12-549-05	12-550-05	12-551-05	5 mm
12-549-06	12-550-06	12-551-06	6 mm
12-549-07	12-550-07	12-551-07	7 mm
12-549-08	12-550-08	12-551-08	8 mm
11.5 cm	13.5 cm	17 cm - 6 3/4"	



12-552-02	12-553-02	12-554-02	2 mm
12-552-03	12-553-03	12-554-03	3 mm
12-552-04	12-553-04	12-554-04	4 mm
12-552-05	12-553-05	12-554-05	5 mm
12-552-06	12-553-06	12-554-06	6 mm
12-552-07	12-553-07	12-554-07	7 mm
12-552-08	12-553-08	12-554-08	8 mm
11.5 cm	13.5 cm	17 cm - 6 3/4"	

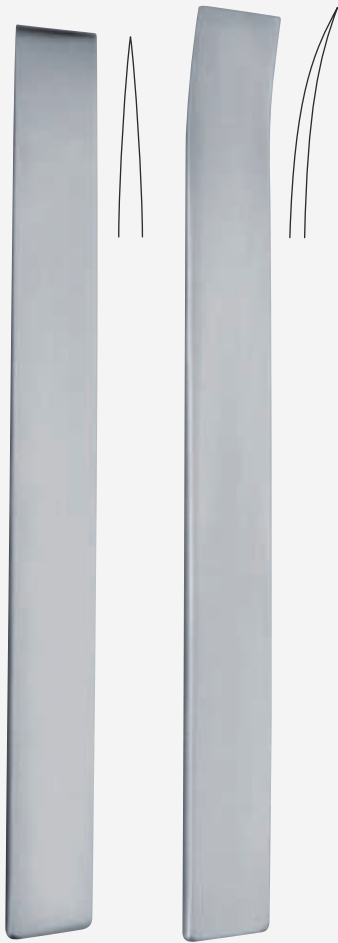

**Lambotte**

12-555-06	12-556-06	6 mm
12-555-08	12-556-08	8 mm
12-555-10	12-556-10	10 mm
12-555-13	12-556-13	13 mm
12-555-15	12-556-15	15 mm
12-555-20	12-556-20	20 mm
12-555-25	12-556-25	25 mm
12-555-30	12-556-30	30 mm
12-555-38	12-556-38	38 mm
12-555-44	12-556-44	44 mm
12-555-50	12-556-50	50 mm
25 cm - 9 3/4"		25 cm - 9 3/4"

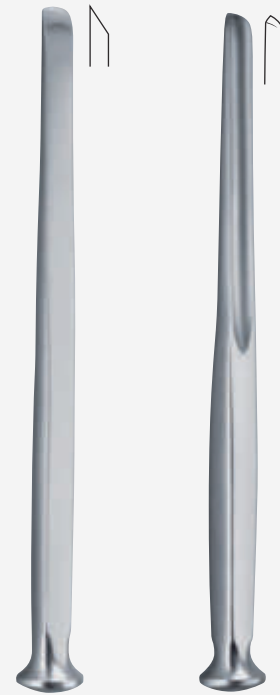

**Alexander**

12-557-04	12-558-04	4 mm
12-557-06	12-558-06	6 mm
12-557-08	12-558-08	8 mm
12-557-10	12-558-10	10 mm
12-557-12	12-558-12	12 mm
12-557-14	12-558-14	14 mm
18 cm - 7"		18 cm - 7"



**Mini-Lambotte**

12-559-03	12-560-03	3 mm
12-559-04	12-560-04	4 mm
12-559-06	12-560-06	6 mm
12-559-08	12-560-08	8 mm
12-559-10	12-560-10	10 mm
12-559-12	12-560-12	12 mm
12-559-15	12-560-15	15 mm
12.5 cm - 5"		17 cm - 6 3/4"

Bone chisels and gouges  
 Knochenmeißel  
 Cinceles, gubias  
 Ciseaux-burins, gouges  
 Bone scalpelli e sgorbie



**Lexer**

12-561-07	12-562-07	12-563-07	12-564-07	7 mm
12-561-10	12-562-10	12-563-10	12-564-10	10 mm
12-561-15	12-562-15	12-563-15	12-564-15	15 mm
12-561-20	12-562-20	12-563-20	12-564-20	20 mm
12-561-25	12-562-25	12-563-25	12-564-25	25 mm
12-561-30	12-562-30	12-563-30	12-564-30	30 mm
22 cm - 8 3/4"	30 cm - 12"	22 cm - 8 3/4"	30 cm - 12"	

Ferrozell handle  
 Ferrozellgrif  
 Mango en Ferrozell  
 Manche en Ferrozell  
 Manico di Ferrozell

**Mini-Lexer**

12-565-04	12-566-04	4 mm
12-565-06	12-566-06	6 mm
12-565-08	12-566-08	8 mm
12-565-10	12-566-10	10 mm
12-565-12	12-566-12	12 mm
18 cm - 7"	18 cm - 7"	

Ferrozell handle  
 Ferrozellgrif  
 Mango en Ferrozell  
 Manche en Ferrozell  
 Manico di Ferrozell



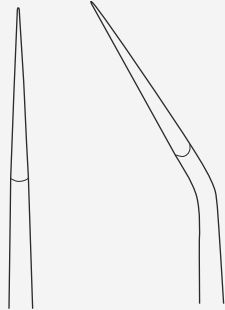

**Dahmen**

12-200-04	12-201-04	12-202-04	12-203-04	4 mm
12-200-05	12-201-05	12-202-05	12-203-05	5 mm
12-200-06	12-201-06	12-202-06	12-203-06	6 mm
12-200-08	12-201-08	12-202-08	12-203-08	8 mm
12-200-10	12-201-10	12-202-10	12-203-10	10 mm
12-200-12	12-201-12	12-202-12	12-203-12	12 mm
12-200-15	12-201-15	12-202-15	12-203-15	15 mm
12-200-20	12-201-20	12-202-20	12-203-20	20 mm
12-200-22	12-201-22	12-202-22	12-203-22	22 mm
12-200-25	12-201-25	12-202-25	12-203-25	25 mm

30 cm - 11 3/4"  
Osteotomes  
straight

30 cm - 11 3/4"  
Osteotomes  
angled

30 cm - 11 3/4"  
Gouges  
straight

30 cm - 11 3/4"  
Gouges  
angled

Ferrozell handle  
Ferrozellgrif  
Mango en Ferrozell  
Manche en Ferrozell  
Manico di Ferrozell



**Zielke**

12-204-05	5.5 mm
12-204-09	9 mm

23 cm - 9"  
Gouges  
Ferrozell handle  
Ferrozellgrif  
Mango en Ferrozell  
Manche en Ferrozell  
Manico di Ferrozell



Cobb

12-205-27

12-205-27A

12-205-27B

12-205-27C

27 cm - 10 3/4"

8 mm

Ferrozell handle  
Ferrozellgrif  
Mango en Ferrozell  
Manche en Ferrozell  
Manico di Ferrozell



**Danis**

12-206-06	12-207-06	12-208-06	12-209-06	6 mm
12-206-09	12-207-09	12-208-09	12-209-09	9 mm
12-206-13	12-207-13	12-208-13	12-209-13	13 mm
12-206-16	12-207-16	12-208-16	12-209-16	16 mm
12-206-25	12-207-25	12-208-25	12-209-25	25 mm
12-206-32	12-207-32	12-208-32	12-209-32	32 mm

27.5 cm - 10 3/4"  
Osteotomes  
straight

27.5 cm - 10 3/4"  
Osteotomes  
curved

27.5 cm - 10 3/4"  
Gouges  
straight

27.5 cm - 10 3/4"  
Gouges  
curved

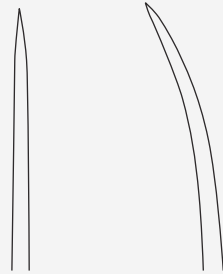

**Capener**

12-210-06	12-211-06	12-212-06	6 mm
12-210-09	12-211-09	12-212-09	9 mm
12-210-10	12-211-10	12-212-10	10 mm
12-210-11	12-211-11	12-212-11	11 mm
12-210-13	12-211-13	12-212-13	13 mm
12-210-15	12-211-15	12-212-15	15 mm
12-210-16	12-211-16	12-212-16	16 mm
12-210-19	12-211-19	12-212-19	19 mm
12-210-20	12-211-20	12-212-20	20 mm
12-210-25	12-211-25	12-212-25	25 mm
12-210-30	12-211-30	12-212-30	30 mm
12-210-32	12-211-32	12-212-32	32 mm

23.5 cm - 9 1/4"  
Gouges

23.5 cm - 9 1/4"  
Gouges

25 cm - 10"  
Gouges

Ferrozell handle  
Ferrozellgrif  
Mango en Ferrozell  
Manche en Ferrozell  
Manico di Ferrozell





**Stille**

12-567-10	12-568-10	12-569-10	12-570-10	12-571-10	10 mm
12-567-15	12-568-15	12-569-15	12-570-15	12-571-15	15 mm
12-567-20	12-568-20	12-569-20	12-570-20	12-571-20	20 mm
12-567-25	12-568-25	12-569-25	12-570-25	12-571-25	25 mm
20 cm - 8"	20 cm - 8"	20 cm - 8"	20 cm - 8"	20 cm - 8"	



**Smith-Petersen**

12-572-06	12-573-06	12-574-06	12-575-06	6 mm
12-572-09	12-573-09	12-574-09	12-575-09	9 mm
12-572-13	12-573-13	12-574-13	12-575-13	13 mm
12-575-16	12-573-16	12-574-16	12-575-16	16 mm
12-575-19	12-573-19	12-574-19	12-575-19	19 mm
12-575-25	12-573-25	12-574-25	12-575-25	25 mm
12-575-32	12-573-32	12-574-32	12-575-32	32 mm
20 cm - 8"	20 cm - 8"	20 cm - 8"	20 cm - 8"	



**Hibbs**

12-576-06	12-577-06	12-578-06	12-579-06	12-580-06	6 mm
12-576-13	12-577-13	12-578-13	12-579-13	12-580-13	13 mm
12-576-19	12-577-19	12-578-19	12-579-19	12-580-19	19 mm
12-576-25	12-577-25	12-578-25	12-579-25	12-580-25	25 mm
12-576-32	12-577-32	12-578-32	12-579-32	12-580-32	32 mm
24 cm - 9 1/2"	24 cm - 9 1/2"	24 cm - 9 1/2"	24 cm - 9 1/2"	24 cm - 9 1/2"	



**Mannerfelt  
modif.**

12-584-03	12-585-03	3 mm
12-584-04	12-585-04	4 mm
12-584-06	12-585-06	6 mm
12-584-08	12-585-08	8 mm
15.5 cm - 6"	15.5 cm - 6"	
Osteotomes	Gouge	
Osteotome	Hohlmeißel	
Osteótomos	Gubia	
Ostéotomes	Gouge	
Osteotomi	Sgorbio	

**Freer**

12-581-15

15 cm - 6"  
6 mm  
Gouge  
Hohlmeißel  
Gubia  
Gouge  
Sgorbio

**Freer**

12-582-16

16 cm - 6 1/4"  
4 mm  
Chisel  
Flachmeißel  
Cinzel  
Ciseau-burin  
Scalpello

**Ballenger**

12-583-04 4 mm

12-583-06 6 mm

12-583-08 8 mm

16 cm - 6 1/4"

Chisels, osteotomes for rhinoplastic  
 Meißel zur Nasenplastik  
 Cinceles para rinoplastica  
 Ostéotomes, ciseaux-burins pour rhinoplastique  
 Scalpelli, osteotomi per rinoplastico



**Kilian**

12-586-16

16 cm - 6 1/4"  
 5 mm



**Kilian-Claus**

12-587-16

16 cm - 6 1/4"  
 5 mm



**Cottle**

12-588-07

7 mm

12-588-12

12 mm

15 cm - 6"



**Cottle**

12-589-19

19 cm - 7 1/2"  
 4 mm



12-590-18

18 cm - 7"  
 6 mm



**Fomon**

12-591-17

4 mm

12-592-17

5 mm

12-593-17

6 mm

12-594-17

7 mm

12-595-17

8 mm

17 cm - 6 3/4"

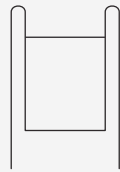

**Cinelli**

12-596-18

10 mm

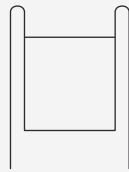

12-597-18

12 mm

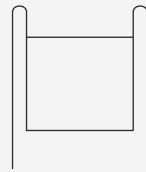

12-598-18

14 mm

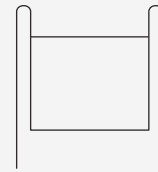

12-599-18

16 mm

18 cm - 7"



**Cottle**

12-600-18

4 mm



12-601-18

7 mm



12-602-18

9 mm



12-603-18

12 mm

18 cm - 7"



**Cottle**

12-604-18

4 mm



12-605-18

7 mm



12-606-18

9 mm



12-607-18

12 mm

18 cm - 7"

Chisels, osteotomes for rhinoplastic  
 Meißel zur Nasenplastik  
 Cinceles para rinoplastica  
 Ostéotomes, ciseaux-burins pour rhinoplastique  
 Scalpelli, osteotomi per rinoplastico

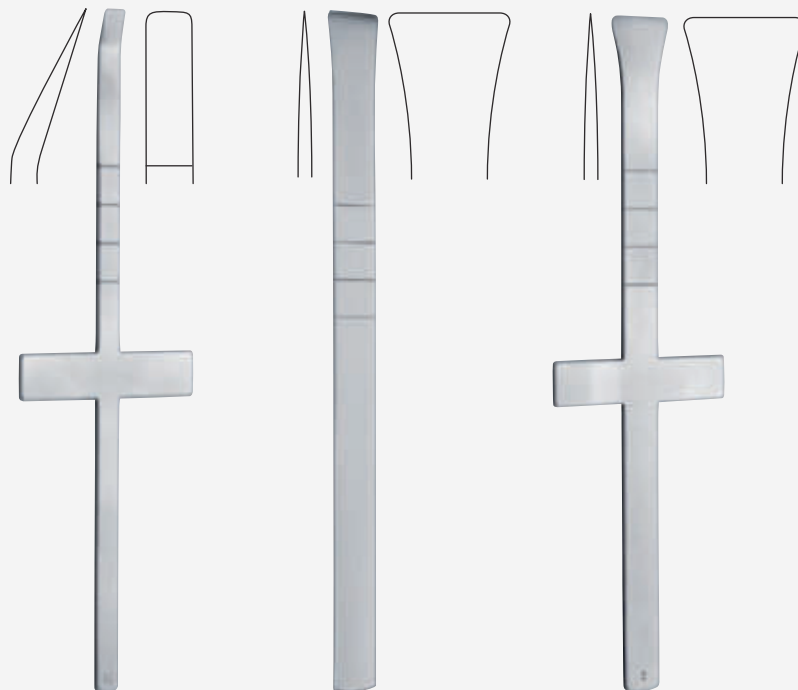

Cottle

12-608-18

6 mm

12-609-18

16 mm

12-610-18

18 cm - 7"

16 mm



Rubin

12-611-18

10 mm



12-612-18

12 mm



12-613-18

14 mm

18 cm - 7"





**Cottle**

12-614-20

4 mm

12-615-20

7 mm

12-616-20

9 mm

12-617-20

12 mm

20 cm - 8"



**Walter**

12-618-19

3 mm

12-619-19

4,5 mm

19 cm - 7 1/2"



**Sheehan**

12-620-16

2 mm

12-621-16

4 mm

12-622-16

6 mm

12-623-16

8 mm

16 cm - 6 1/4"

12-624-16

10 mm

12-625-16

12 mm

12-626-16

15 mm

12-627-16

18 mm

Chisels, osteotomes for rhinoplastic  
 Meißel zur Nasenplastik  
 Cinceles para rinoplastica  
 Ostéotomes, ciseaux-burins pour rhinoplastique  
 Scalpelli, osteotomi per rhinoplastic

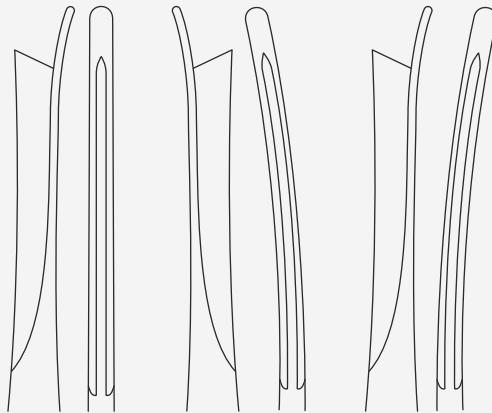

**Silver**

12-628-18

straight  
 gerade  
 recta  
 droit  
 retta

12-629-18

right  
 rechts  
 derecha  
 droite  
 destra

12-630-18

left  
 links  
 izquierda  
 gauche  
 sinistra

18 cm - 7"

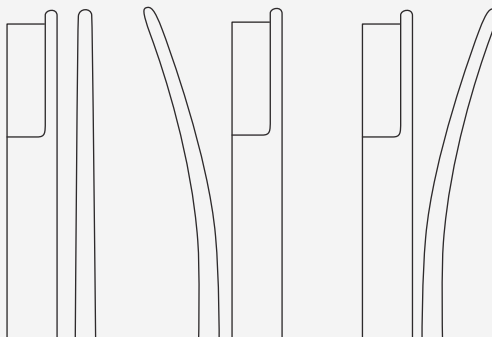

**Neivert-Anderson**

12-631-20

straight  
 gerade  
 recta  
 droit  
 retta

12-632-20

right  
 rechts  
 derecha  
 droite  
 destra

12-633-20

left  
 links  
 izquierda  
 gauche  
 sinistra

20 cm - 8"



Obwegeser  
12-634-23  
23.5 cm - 9 1/4"  
11 mm



Obwegeser  
12-635-21 7 mm  
12-636-21 10 mm 21.5 cm - 8 1/2"

Ferrozell handle  
Ferrozellgrif  
Mango en Ferrozell  
Manche en Ferrozell  
Manico di Ferrozell



**Temper**

12-637-15	12-638-15	12-639-15	12-640-15	12-641-15	12-642-15	12-643-15	15.5 cm - 6"
2 mm Ø	3 mm Ø	4 mm Ø	5 mm Ø	6 mm Ø	8 mm Ø	10 mm Ø	



**Passow**

12-644-12	12-645-12	12 cm - 4 3/4"
Fig.1	Fig.2	
2.5 mm x 2.5 mm	3.5 mm x 3.5 mm	



**Caspar**

12-646-20	12-647-20	12-648-20	20 cm - 8"
3 mm Ø	5 mm Ø	8 mm Ø	

Ferrozell handle  
 Ferrozellgrif  
 Mango en Ferrozell  
 Manche en Ferrozell  
 Manico di Ferrozell



**Temper Modified**

12-649-20	12-650-20	12-651-20	20 cm - 8"
12 mm Ø	14 mm Ø	16 mm Ø	

Ferrozell handle  
 Ferrozellgrif  
 Mango en Ferrozell  
 Manche en Ferrozell  
 Manico di Ferrozell



**Brill**

12-262-03

3 mm

12-262-05

5 mm

12-262-08

8 mm

20 cm - 8"

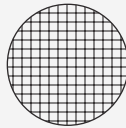
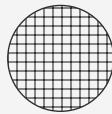

12-263-12

12 mm

12-263-14

14 mm

12-263-16

16 mm

20 cm - 8"

Ferrozell handle

Ferrozellgrif

Mango en Ferrozell

Manche en Ferrozell

Manico di Ferrozell



**Ivanio**

12-264-03

3 x 8 mm

12-264-04

4 x 10 mm

29 cm - 11 1/2"



12-264-05

5 x 15 mm

12-264-06

6 x 20 mm

29 cm - 11 1/2"

Ferrozell handle

Ferrozellgrif

Mango en Ferrozell

Manche en Ferrozell

Manico di Ferrozell



**Moston**

12-265-02

2 x 9 mm

12-265-06

6 x 9 mm

22.5 cm - 8 3/4"

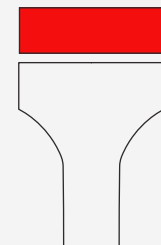

12-265-03

3 x 16 mm

12-265-06

6 x 19 mm

22.5 cm - 8 3/4"









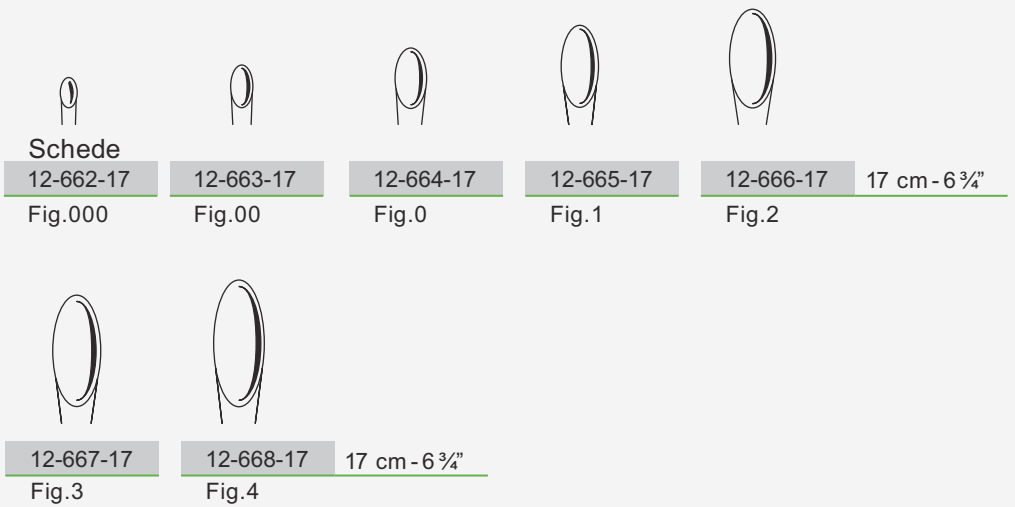
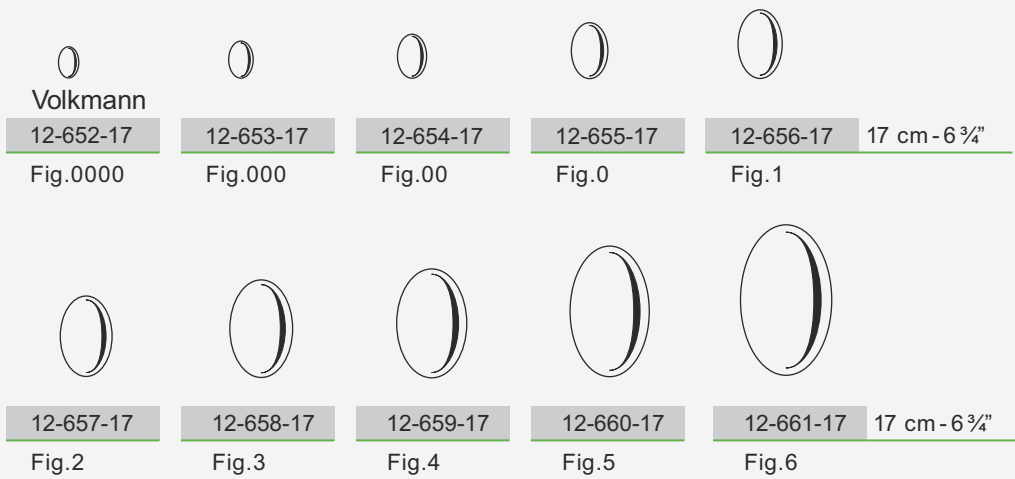

12-265-08

225.5 cm - 8 3/4"









Ø 8 mm





Spratt		
		
12-669-17 Fig.0000	12-670-17 Fig.000	12-671-17 Fig.00
17 cm - 6 3/4"		
		
12-672-17 Fig.0	12-673-17 Fig.1	12-674-17 Fig.2
17 cm - 6 3/4"		
		
12-675-17 Fig.3	12-676-17 Fig.4	12-677-17 Fig.5
17 cm - 6 3/4"		



Bruns		
		
12-678-16 Fig.000	12-679-16 Fig.00	12-680-16 Fig.0
16 cm - 6 1/4"		
		
12-681-16 Fig.1	12-682-16 Fig.2	12-683-16 Fig.3
16 cm - 6 1/4"		
		
12-684-16 Fig.4	12-685-16 Fig.5	12-686-16 Fig.6

Bone curettes  
 Scharfe Löffel  
 Cucharillas cortantes  
 Curettes tranchantes  
 Curette Bone



Volkman						
12-687-18	12-688-18	12-689-18	12-690-18	12-691-18	12-692-18	18.5 cm - 7 1/4"
Fig.0000	Fig.000	Fig.00	Fig.0	Fig.1	Fig.2	
12-693-19	12-694-19	12-695-19	12-696-19	19 cm - 7 1/2"		
Fig.3	Fig.4	Fig.5	Fig.6			
12-697-27	12-698-27	12-699-27	12-700-27	12-701-27	27.5 cm - 10 3/4"	
Fig.0	Fig.1	Fig.2	Fig.3	Fig.4		

oval, Ferrozell handle  
 oval, Ferrozellgrif  
 ovalada, Mango en Ferrozell  
 ovale, Manche en Ferrozell  
 ovale, Manico di Ferrozell

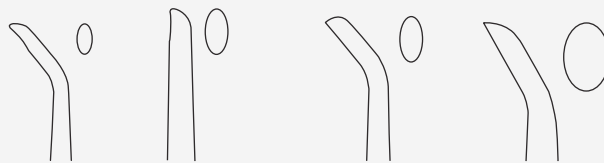

**Bruns**

12-213-43	12-214-43	12-215-43	12-216-43	43 cm - 17"
12-213-50	12-214-50	12-215-50	12-216-50	50 cm - 19 3/4"
2 mm	3 mm	3 mm	6 mm	

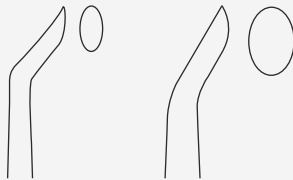

**Epstein**

12-217-43	12-218-43	43 cm - 17"
12-217-50	12-218-50	50 cm - 19 3/4"
3 mm	6 mm	



**Scoville**

12-219-50	50 cm - 19 3/4"
9 mm	

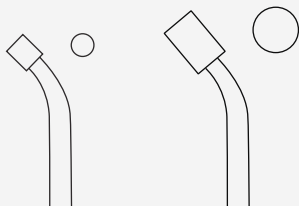

**Cone**

12-220-43	12-221-43	43 cm - 17"
12-220-50	12-221-50	50 cm - 19 3/4"
Ø 3 mm	Ø 6 mm	







**Halle**

12-702-21    12-703-21    12-704-21    21 cm - 8 1/4"

Fig. 1  
flexible  
flexibel  
flexible  
flexible  
flessibile



Fig.2

Fig.3



**Uffenorde**

12-705-17

Fig.1



12-706-17

Fig.2

17 cm - 6 3/4"



**Bruns**

12-707-23    12-708-23    12-709-23    12-710-23    23 cm - 9"

Fig.00

Fig.0

Fig.1

Fig.2



12-711-23

Fig.3

12-712-23

Fig.4

12-713-23

Fig.5

12-714-23

Fig.6

23 cm - 9"

solid  
massiv  
macizo  
solide  
massicio



Schroeder  
 12-715-30

Fig.1



12-716-30

Fig.2



12-717-30

Fig.3

30 cm - 12"



12-718-30

Fig.4



12-719-30

Fig.5



12-720-30

Fig.6

30 cm - 12"

sharp / rigid  
 scharf / fest  
 tranchante / rigide  
 cortante / rigida  
 tagliente / rigido



Simon

12-721-24

Fig.0000



12-722-24

Fig.000



12-723-24

Fig.00



12-724-24

Fig.0

24 cm - 9 1/2"

sharp / rigid  
 scharf / fest  
 cortante / rigida  
 tranchante / rigide  
 tagliente / rigido



Simon

12-725-25

Fig.1



12-726-25

Fig.2



12-727-25

Fig.3

25 cm - 9 3/4"



12-728-25

Fig.4



12-729-25

Fig.5



12-730-25



Fig.6



25 cm - 9 3/4"



sharp / rigid  
 scharf / fest  
 cortante / rigida  
 tranchante / rigide  
 tagliente / rigido











			
<b>Akson</b>			
12-731-20	12-732-20	12-733-20	20 cm - 8"
Fig.000	Fig.00	Fig.0	



			
12-734-20	12-735-20	12-736-20	20 cm - 8"
Fig.1	Fig.2	Fig.3	

			
12-737-20	12-738-20	12-739-20	20 cm - 8"
Fig.4	Fig.5	Fig.6	
straight			
gerade			
recta			
droit			
retto			







			
12-740-20	12-741-20	12-742-20	20 cm - 8"
Fig.000	Fig.00	Fig.0	

			
12-743-20	12-744-20	12-746-20	20 cm - 8"
Fig.1	Fig.2	Fig.3	

			
12-747-20	12-748-20	12-749-20	20 cm - 8"
Fig.4	Fig.5	Fig.6	
curved			
gebogen			
courbe			
curva			
curvo			



				
<b>Miguel</b>				
12-750-25	12-751-25	12-752-25	12-753-25	25 cm - 9 3/4"
Fig.000	Fig.00	Fig.0	Fig.1	
3.6 mm	4.4 mm	5.2 mm	6.8 mm	
straight				
gerade				
recta				
droit				
retto				

				
<b>Daubenspeck</b>				
12-754-20	12-756-20	12-757-20	12-758-20	20 cm - 8"
Fig.0000	Fig.000	Fig.00	Fig.0	
2.8 mm	3.6 mm	4.4 mm	5.2 mm	





Scoville

12-759-25

12-760-25

12-761-25

25 cm - 9 3/4"

Fig.1

Fig.2

Fig.3

oval  
 oval  
 ovalada  
 ovale  
 ovale



Lempert

12-762-21

12-763-21

12-764-21

12-765-21

12-766-21

21.5 cm - 8 1/2"

Fig.00000

Fig.0000

Fig.000

Fig.00

Fig.0

1.8 mm

2.0 mm

2.4 mm

2.6 mm

2.8 mm



**Bruns**

○	12-251-01 3.3 mm	12-251-02 3.3 mm	12-251-03 3.3 mm	Fig. 000	23 cm - 9"
○	12-252-01 3.9 mm	12-253-02 3.9 mm	12-254-03 3.9 mm	Fig. 00	23 cm - 9"
○	12-255-01 4.7 mm	12-255-02 4.7 mm	12-255-03 4.7 mm	Fig. 0	23 cm - 9"
○	12-256-01 5.3 mm	12-256-02 5.3 mm	12-256-03 5.3 mm	Fig. 1	23 cm - 9"
○	12-257-01 6 mm	12-257-02 6 mm	12-257-03 6 mm	Fig. 2	23 cm - 9"
○	12-258-01 7.2 mm	12-258-02 7.2 mm	12-258-03 7.2 mm	Fig. 3	23 cm - 9"
○	12-259-01 8.2 mm	12-259-02 8.2 mm	12-259-03 8.2 mm	Fig. 4	23 cm - 9"
○	12-260-01 9.8 mm	12-260-02 9.8 mm	12-260-03 9.8 mm	Fig. 5	23 cm - 9"
○	12-261-01 12 mm	12-261-02 12 mm	12-261-03 12 mm	Fig. 6	23 cm - 9"



Volkman  
 Fig. 1

12-767-13

12-767-14

12-767-16

12-767-17

12-767-20

oval/oval  
 oval/oval  
 ovalada/ovalada  
 ovale/ovale  
 ovale/ovale



Fig. 2

12-768-13 13 cm - 5"

12-768-14 14 cm 5 1/2"

12-768-16 16 cm - 6 1/4"

12-768-17 17 cm - 6 3/4"

12-768-20 20 cm - 8"

round/oval  
 rund/oval  
 redonda/ovalada  
 ronde/ovale  
 rotondo/ovale



Fig. 3

12-769-21

21 cm - 8 1/4"  
 round/oval  
 rund/oval  
 redonda/ovalada  
 ronde/ovale  
 rotondo/ovale



**Martini**

12-770-13	12-771-13	12-772-13	13.5 cm - 5 1/4"
Fig.00	Fig.0	Fig.1	
Fig.0	Fig.1	Fig.2	

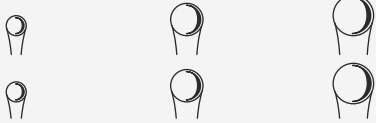

**Martini**

12-773-15	12-774-15	12-775-15	15.5 cm 6"
Fig.00	Fig.0	Fig. 1	
Fig.00	Fig.0	Fig. 1	

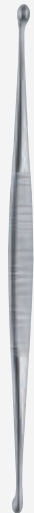

**Williger**

12-776-13	12-777-13	12-778-13	13.5 cm 5 1/4"
Fig.00	Fig.0	Fig.1	
Fig.0	Fig.1	Fig.2	

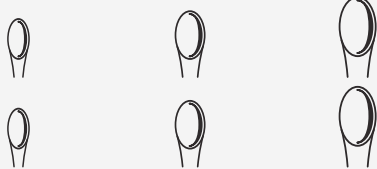

**Williger**

12-779-15	12-780-15	12-781-15	15.5 cm - 6"
Fig.00	Fig.0	Fig. 1	
Fig.00	Fig.0	Fig. 1	

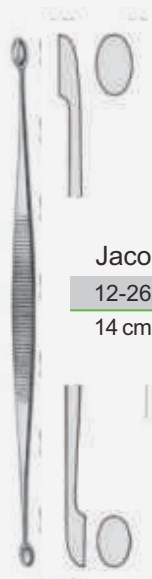
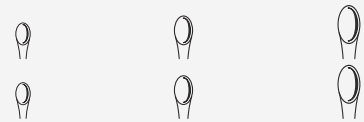

**Jacobson**

12-262-14	14 cm - 5 1/2"
-----------	----------------

Periosteal elevators for maxillo-facial surgery  
 Raspatorien für die Kieferchirurgie  
 Periostótomos para la cirugía maxilofacial  
 Rugines – Décolleurs pour la chirurgie maxillo-faciale  
 Scollaperiostio per la chirurgia maxillo-facciale

**comed**  
 operate better with us

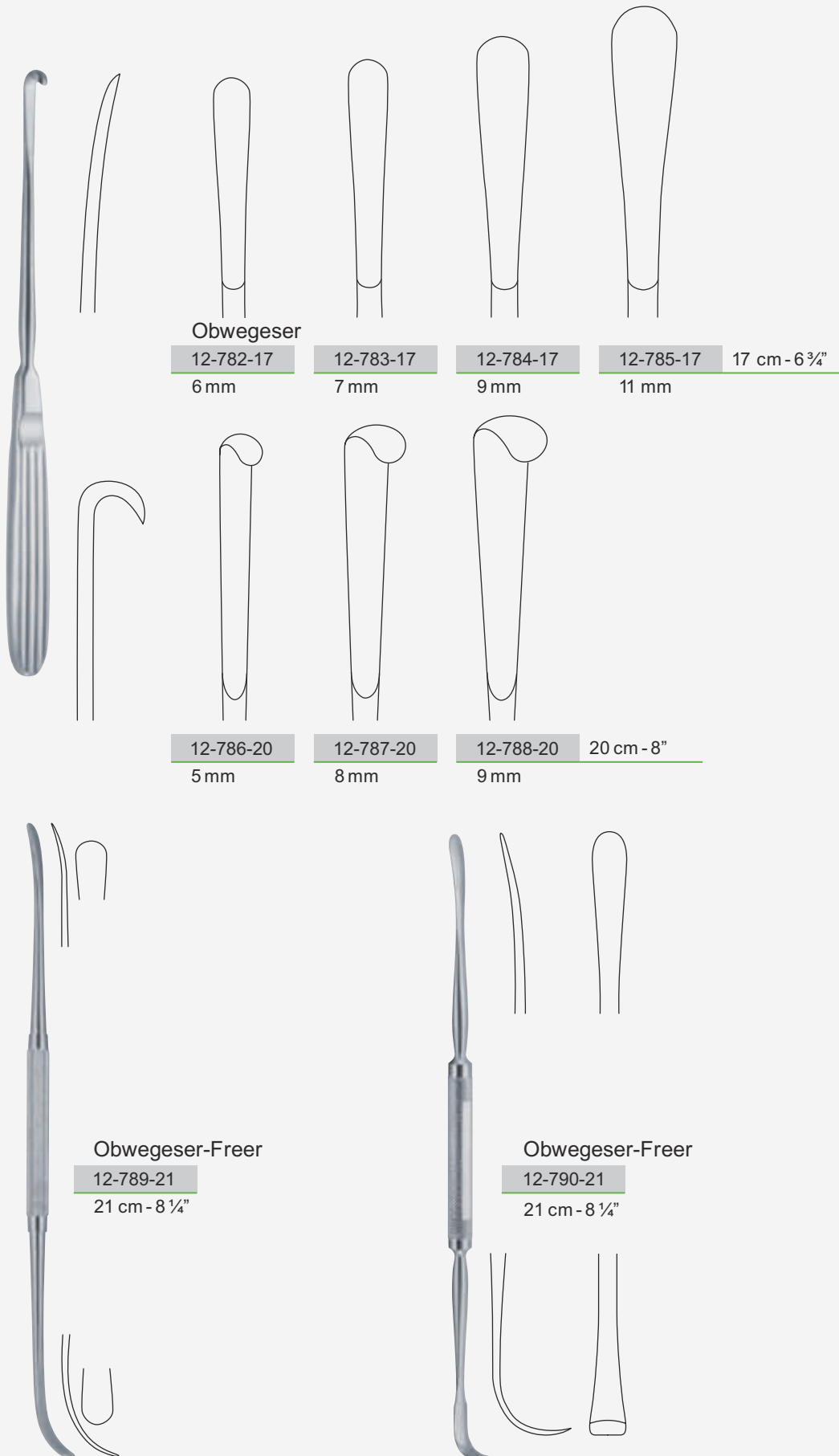



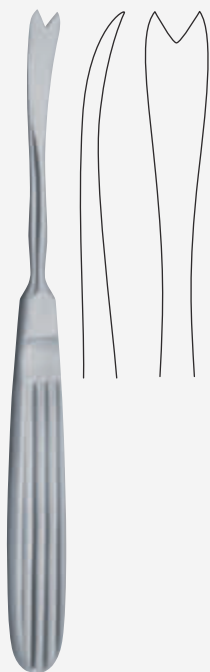

Obwegeser  
 12-791-17  
 17.5 cm - 7"



Obwegeser  
 12-792-23  
 23 cm - 9"



Obwegeser  
 12-793-18  
 18 cm - 7"



Obwegeser  
 12-794-14  
 14 cm - 5 ½"

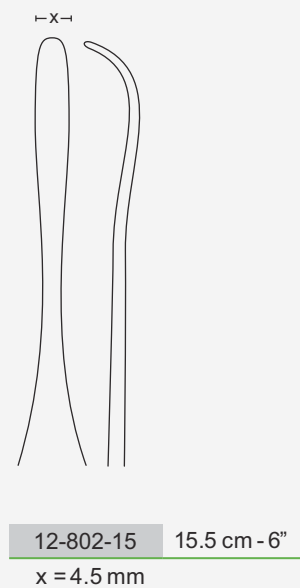
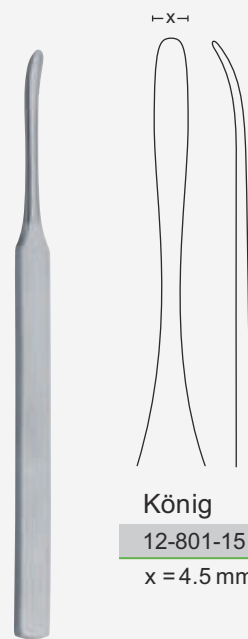
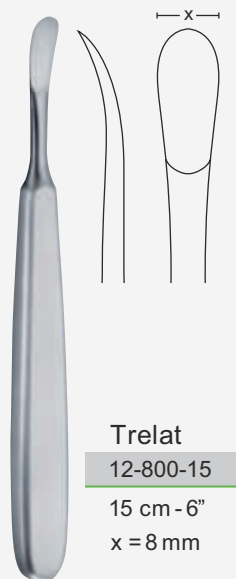
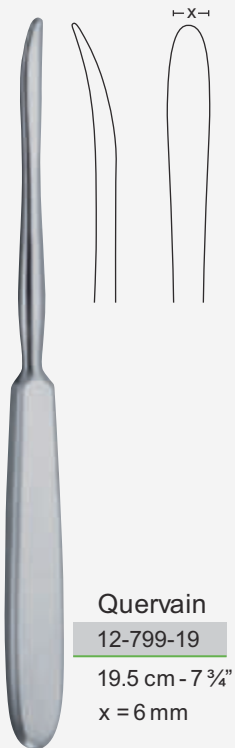
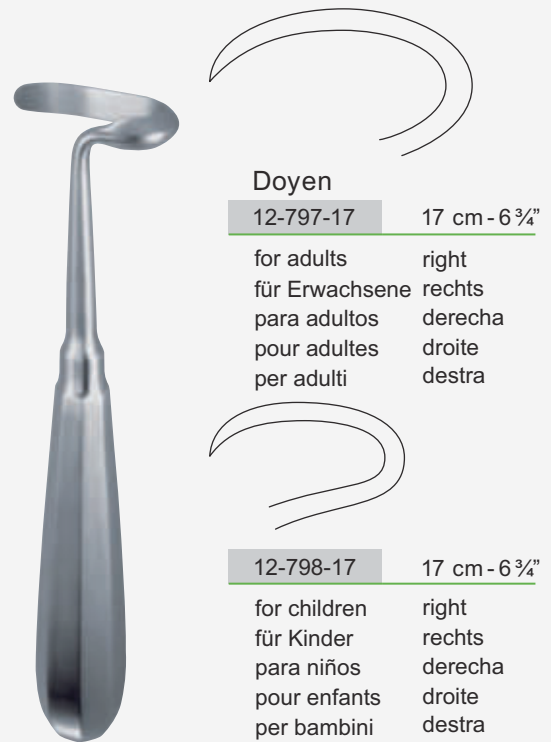

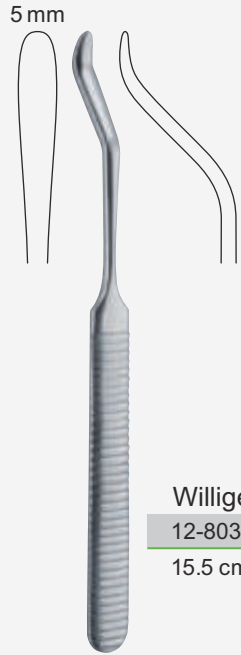

**Williger**  
12-803-15  
15.5 cm - 6"



**Alderdyce**  
12-804-21  
21 cm - 8 1/4"

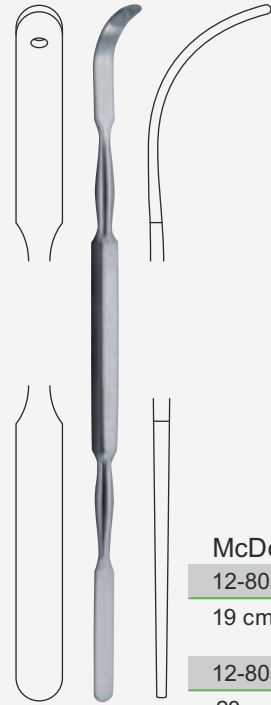

**McDonald**  
12-805-19  
19 cm - 7 1/2"  
12-805-23  
23 cm - 9"  
Less curved  
Without hole

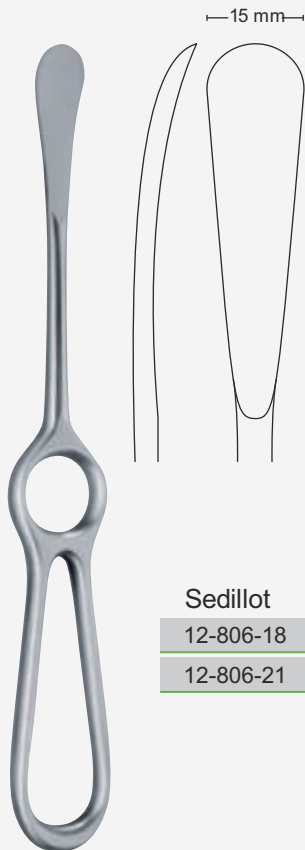

**Sedillot**  
12-806-18 18.5 cm - 7 1/4"  
12-806-21 21 cm - 8 1/4"

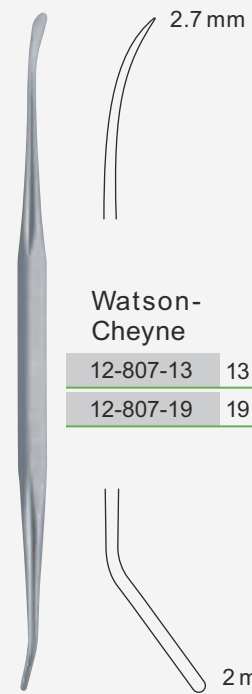

**Watson-Cheyne**  
12-807-13 13 cm - 5 1/4"  
12-807-19 19 cm - 7 1/2"

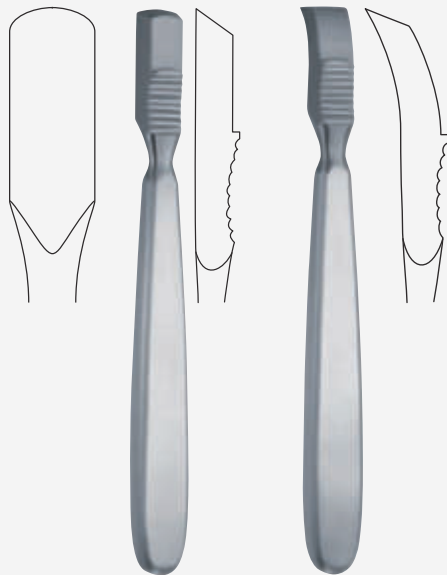

**Farabeuf**

12-808-15

straight  
 gerade  
 recta  
 droit  
 retto

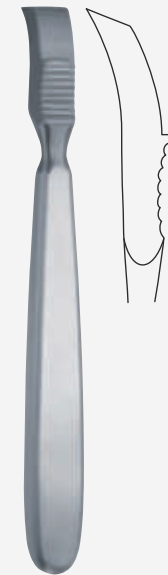

12-809-15 15 cm - 6"

curved  
 gebogen  
 curva  
 courbe  
 curvo

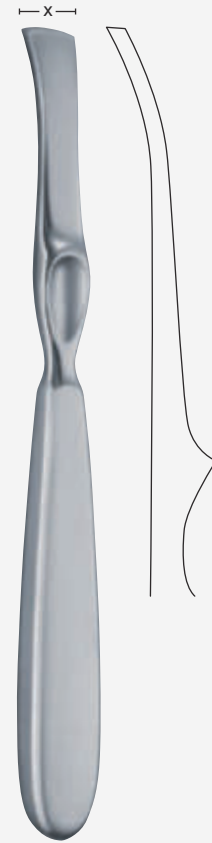

**Lambotte**

12-810-05 x = 5 mm

12-810-10 x = 10 mm

12-810-15 x = 15 mm

12-810-20 x = 20 mm

12-810-25 x = 25 mm

21 cm - 8 1/4"

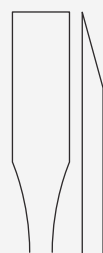

**Adson**

12-811-17

Fig.1



12-812-17

Fig.2



12-813-17

Fig.3



12-814-17

Fig.4

17 cm - 6 3/4"

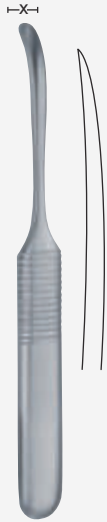

Williger

12-815-13 13 cm - 5"  
x = 5 mm



Williger

12-816-16 x = 4 mm

12-817-16 x = 6 mm

16 cm - 6 1/4"



Williger

12-818-16

x = 5 mm



12-819-16

x = 6.5 mm

16 cm - 6 1/4"

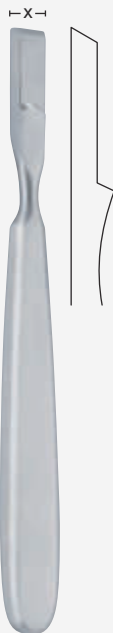

Farabeuf-  
Collin

12-820-16

x = 11 mm



12-821-16

x = 11 mm

16 cm - 6 1/4"

Periosteal raspatories – Elevators  
 Raspatorien – Elevatorien  
 Raspatorios – Elevadores  
 Rugines – Elevateurs  
 Periosteal raspatories – Elevators



Obwegeser

12-822-15  
2.5 mm



12-823-15  
4 mm



15 cm - 6"



Obwegeser

12-824-18  
18.5 cm - 7 1/4"



Obwegeser

12-825-18  
18.5 cm - 7 1/4"



Semb

12-826-17  
17.5 cm - 7"  
12 mm



12-827-21  
21 cm - 8 1/4"  
12 mm



12-828-17  
17.5 cm - 7"  
13 mm



12-829-21  
21 cm - 8 1/4"  
13 mm



12-830-22  
22.5 cm - 8 3/4"  
13 mm



12-831-22  
22.5 cm - 8 3/4"  
15 mm



**Howarth**  
12-832-21  
21.5 cm - 8 1/2"  
sharp / blunt  
scharf / stumpf  
aguda / roma  
pointu / mousse  
acuta / smussa



**Langenbeck**  
12-833-18  
18 cm - 7"



**Langenbeck**  
12-834-19  
19 cm - 7 1/2"

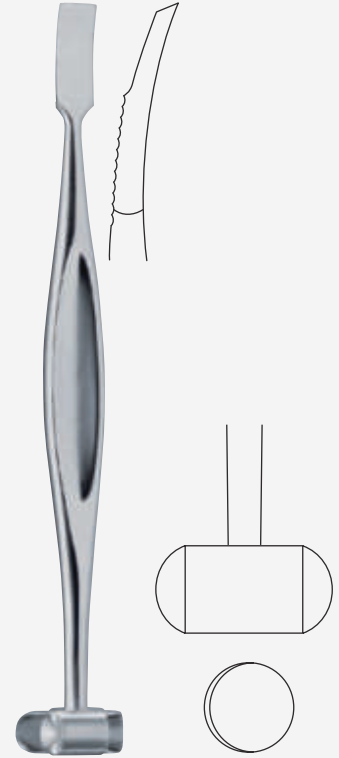

**Alexander**  
12-835-20  
20 cm - 8"



**Langenbeck**  
12-836-20  
x = 8 mm  
20 cm - 8"



**Langenbeck**  
12-837-20  
x = 10 mm  
20 cm - 8"

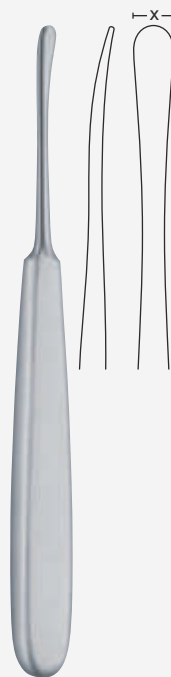

**Sebileau**  
12-838-17 17.5 cm - 7"  
x = 5 mm



extremely light  
extrem leicht  
extremamente ligero  
extrêmement léger  
estremamente legera

**Maxon**  
12-839-17 17.5 cm - 7"



**Schneider**  
 12-222-17  
 17.5 cm - 7"  
 13 mm



**Schneider-Sauerbruch**  
 12-223-19  
 19 cm - 7 1/2"  
 13 mm

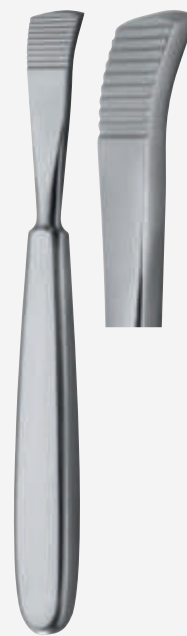

**Jansen**  
 12-224-16  
 16.5 cm - 6 1/2"  
 15 mm



**Cushing**  
 12-225-19  
 19.5 cm - 7 3/4"  
 5 mm



left right  
**Jones**  
 12-226-14 12-227-14 14 cm - 5 1/2"  
 4 mm 4 mm





Cushing-Hopkins

12-228-19

19 cm - 7 1/2"



Jones Modified

12-229-06 6 mm

12-229-08 8 mm

17 cm - 6 3/4"

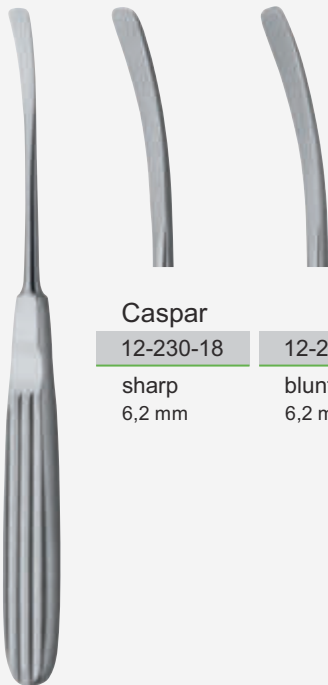

Caspar

12-230-18

sharp  
6,2 mm

12-231-18

blunt  
6,2 mm

18 cm - 7"

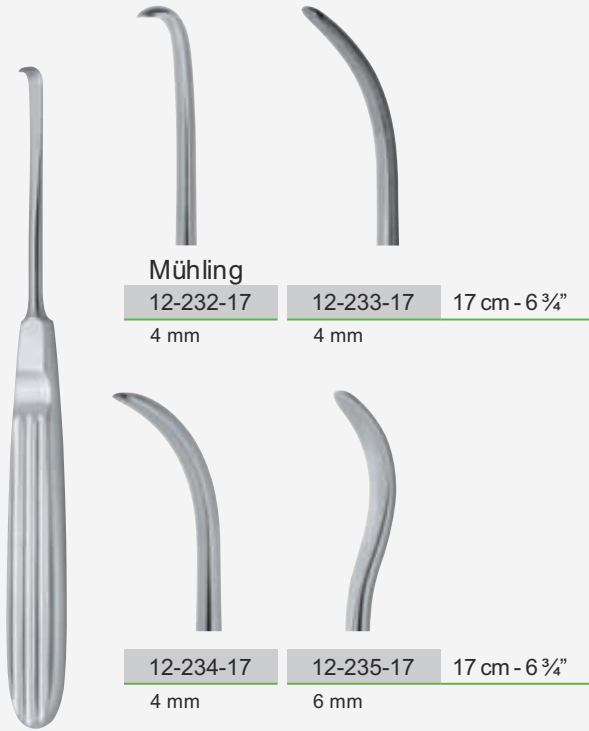

**Mühling**

12-232-17	12-233-17	17 cm - 6 3/4"
-----------	-----------	----------------

4 mm	4 mm	
------	------	--

12-234-17	12-235-17	17 cm - 6 3/4"
-----------	-----------	----------------

4 mm	6 mm	
------	------	--

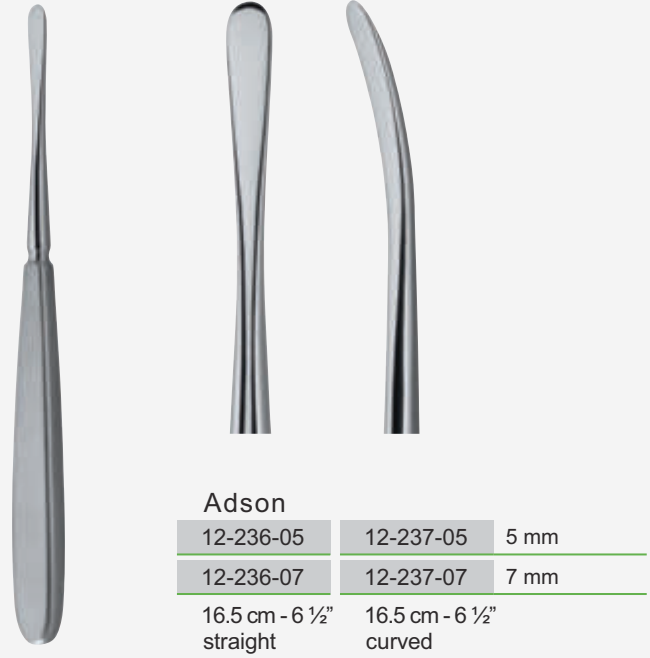

**Adson**

12-236-05	12-237-05	5 mm
-----------	-----------	------

12-236-07	12-237-07	7 mm
-----------	-----------	------

16.5 cm - 6 1/2" straight	16.5 cm - 6 1/2" curved	
------------------------------	----------------------------	--



**Manerfelt**

12-238-03	12-239-03	12-240-03	12-241-03	3 mm
-----------	-----------	-----------	-----------	------

12-238-04	12-239-04	12-240-04	12-241-04	4 mm
-----------	-----------	-----------	-----------	------

12-238-06	12-239-06	12-240-06	12-241-06	6 mm
-----------	-----------	-----------	-----------	------

12-238-07	12-239-07	12-240-07	12-241-07	7 mm
-----------	-----------	-----------	-----------	------

12-238-08	12-239-08	12-240-08	12-241-08	8 mm
-----------	-----------	-----------	-----------	------

12-238-09	12-239-09	12-240-09	12-241-09	9 mm
-----------	-----------	-----------	-----------	------

15.5 cm - 6"



12-242-03	12-243-03	12-244-03	3.5 mm
-----------	-----------	-----------	--------

12-242-04	12-243-04	12-244-04	4 mm
-----------	-----------	-----------	------

12-242-05	12-243-05	12-244-05	5 mm
-----------	-----------	-----------	------

12-242-06	12-243-06	12-244-06	6 mm
-----------	-----------	-----------	------

15.5 cm - 6"

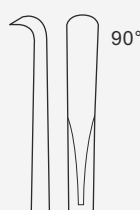

12-242-03	12-243-03	12-244-03	3.5 mm
-----------	-----------	-----------	--------

12-242-04	12-243-04	12-244-04	4 mm
-----------	-----------	-----------	------

12-242-05	12-243-05	12-244-05	5 mm
-----------	-----------	-----------	------

12-242-06	12-243-06	12-244-06	6 mm
-----------	-----------	-----------	------

15.5 cm - 6"

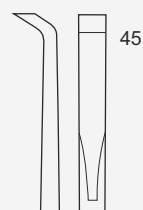

12-242-03	12-243-03	12-244-03	3.5 mm
-----------	-----------	-----------	--------

12-242-04	12-243-04	12-244-04	4 mm
-----------	-----------	-----------	------

12-242-05	12-243-05	12-244-05	5 mm
-----------	-----------	-----------	------

12-242-06	12-243-06	12-244-06	6 mm
-----------	-----------	-----------	------

15.5 cm - 6"

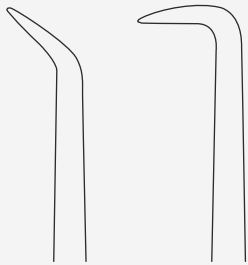

angled, sharp

Vally

12-245-45

43 cm - 17"  
45°

12-245-90

43 cm - 17"  
90°



Cobb

12-246-06

43 cm - 17"  
6 mm



12-247-06

50 cm - 19 3/4"  
6 mm



12-247-10

50 cm - 19 3/4"  
10 mm



12-247-13

50 cm - 19 3/4"  
13 mm



**Cobb**

12-840-29	x = 10 mm
12-841-29	x = 13 mm
12-842-29	x = 19 mm

29 cm - 11 1/2"

Spinal raspatory  
 Wirbelsäulen-Raspatorium  
 Rugine vertebral  
 Raspatorio vertebral  
 Periostotomo vertebrale



**Key**

12-843-18	12-844-19	12-845-19
18 cm - 7"	19 cm - 7 1/2"	19 cm - 7 1/2"
x = 6 mm	x = 10 mm	x = 12 mm

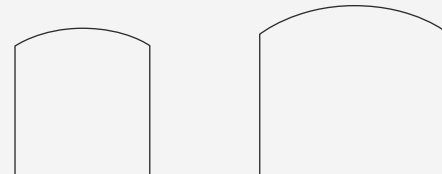
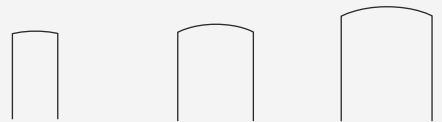

12-846-20	12-847-21
20 cm - 8"	21 cm - 8 1/4"
x = 19 mm	x = 25 mm

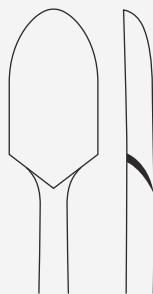

**Steger Round**

12-848-20

Fig.1  
14 mm  
straight  
gerade  
droit  
recta  
rette

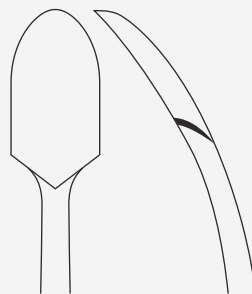

12-849-20

Fig.2  
14 mm  
curved  
gebogen  
courbe  
curva  
curve

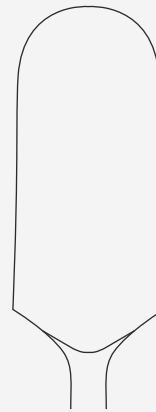

12-850-20 20 cm - 8"

Fig.3  
20 mm  
gerade  
straight  
droit  
recta  
rette

Ferrozell handle  
Ferrozellgrif  
Manche en Ferrozell  
Mango en Ferrozell  
Manico di Ferrozell



**Steger Slim**

12-851-18

Fig.1  
6 mm  
18 cm - 7"

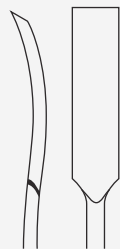

12-852-18

Fig.2  
3 mm  
18 cm - 7"

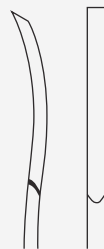

12-853-18

Fig.3  
6 mm  
18 cm - 7"

Ferrozell handle  
Ferrozellgrif  
Mango en Ferrozell  
Manche en Ferrozell  
Manico di Ferrozell



**Steger Angled**

12-248-19

19 cm - 7 1/2"  
angled  
13 mm



12-249-19

19 cm - 7 1/2"  
straight  
13 mm



Hohmann

12-854-22

22 cm - 8 3/4"  
x = 8 mm

12-855-22

24 cm - 9 1/2"  
x = 18 mm

12-856-24

24 cm - 9 1/2"  
x = 43 mm

12-857-24

24 cm - 9 1/2"  
x = 70 mm



**Hohmann**

12-858-24

24.5 cm - 9 3/4"  
x = 43 mm

12-859-26

26 cm - 10 1/4"  
x = 22 mm

12-860-28

28 cm - 11"  
x = 33 mm

12-861-26

26.5 cm - 10 1/2"  
x = 24 mm

12-862-26

26 cm - 10 1/4"  
x = 22 mm

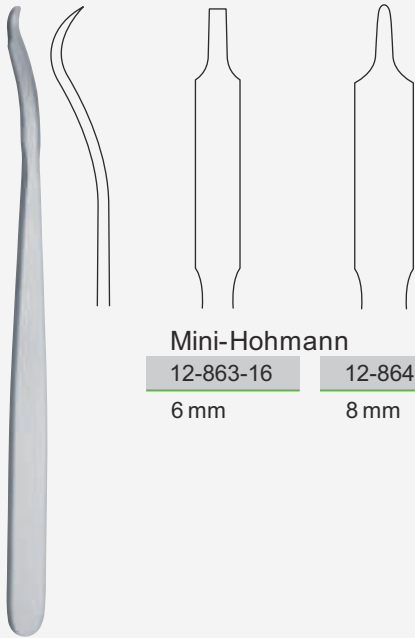

Mini-Hohmann

12-863-16	12-864-16	16 cm - 6 1/4"
6 mm	8 mm	

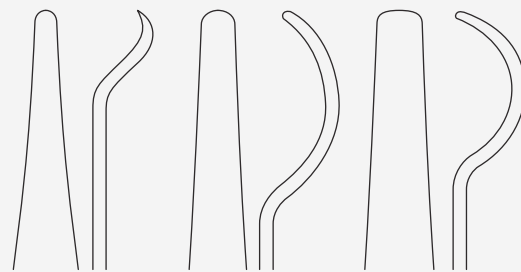

Curvy

12-865-14	12-866-14	12-867-14	14 cm - 5 1/2"
2.8 mm	4.5 mm	6 mm	

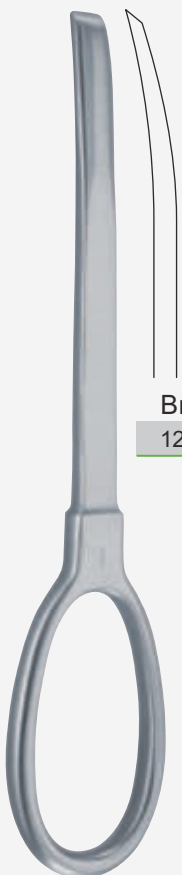

Bristow

12-868-23	23 cm - 9"
-----------	------------



Lane

12-869-21	21 cm - 8 1/4"
-----------	----------------



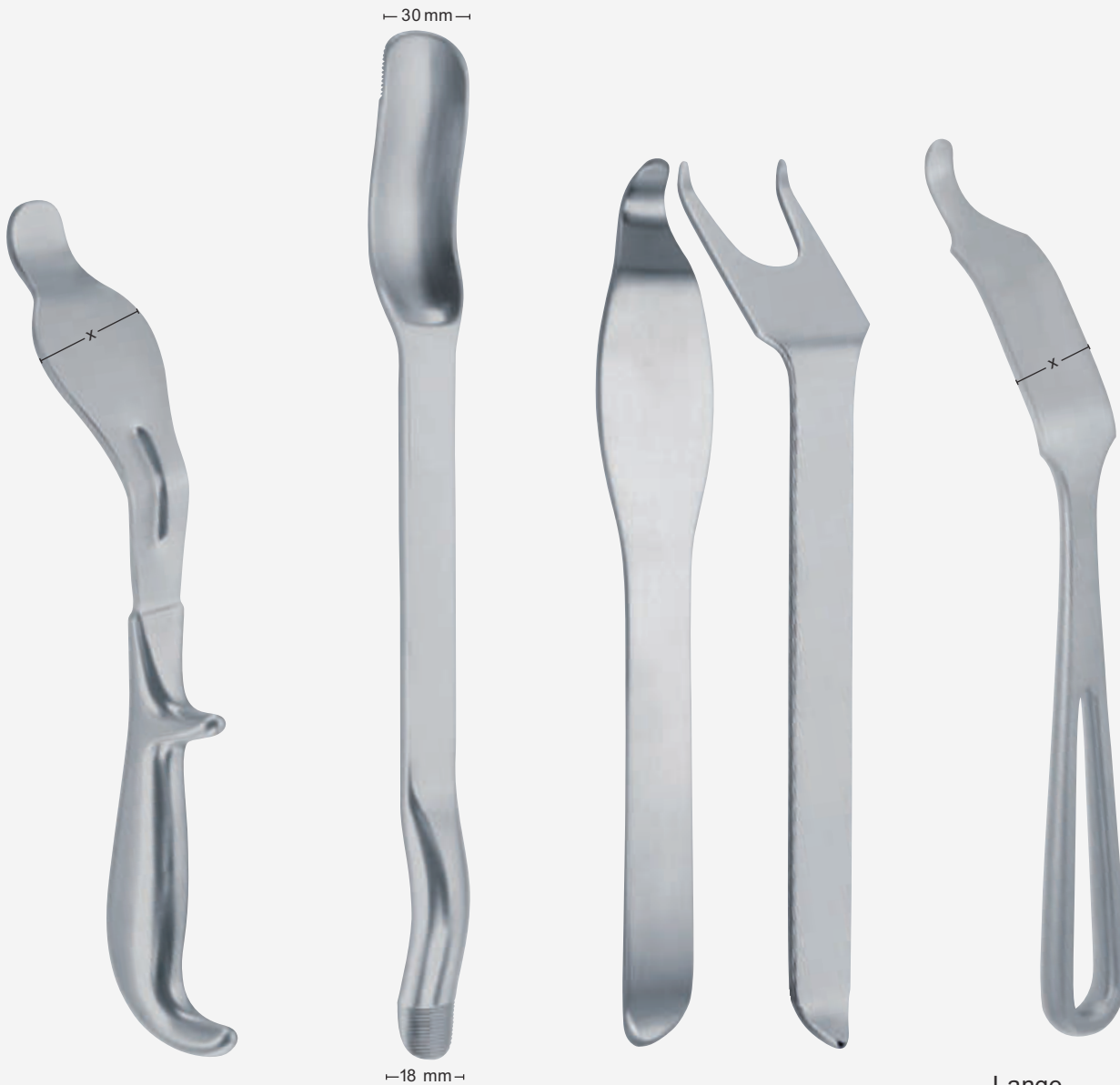

**Bennett**

12-870-24 x = 43 mm

12-871-24 x = 60 mm

24 cm - 9 1/2"

**Murphy-Lane**

12-872-34

34 cm - 13 1/2"

Luxation lever  
Luxationshebel  
Palanca de luxación  
Levier de luxation  
Leva per luxazione

**Blount**

12-873-26

**Lane**

12-874-26

26 cm - 10 1/4"

**Lange-  
Hohmann mod.**

12-875-26

26.5 cm - 10 1/2"

x = 30 mm

12-876-28

28 cm - 11"

x = 33 mm



**Hohmann-Williger**  
 12-877-16  
 16 cm - 6 1/4"

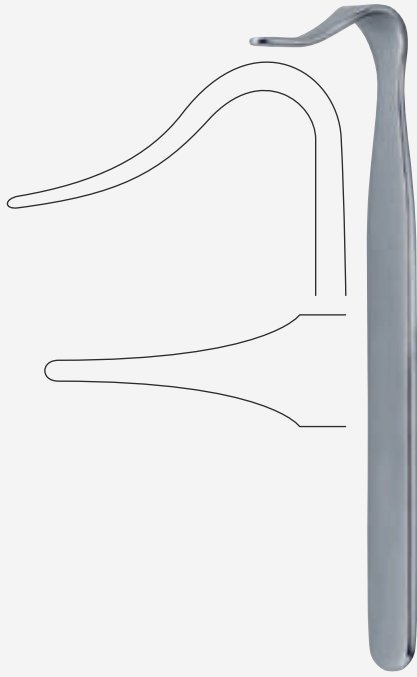

**Blount**  
 12-878-17  
 17.5 cm - 7"



**Taylor**  
 12-879-16 a = 75 mm - b = 30 mm  
 12-880-16 a = 100 mm - b = 30 mm  
 16.5 cm - 6 1/2"

Meniscotomy knives  
 Meniskotome  
 Bisturías para meniscos  
 Bistouries à ménisques  
 Coltelli Meniscotomy



**Bircher**  
 12-881-19  
 19 cm - 7 1/2"



**Smillie**  
 12-882-17  
 17 cm - 6 3/4"  
 Fig. 1



12-883-17  
 17 cm - 6 3/4"  
 Fig. 2



12-884-17  
 17 cm - 6 3/4"  
 Fig. 3

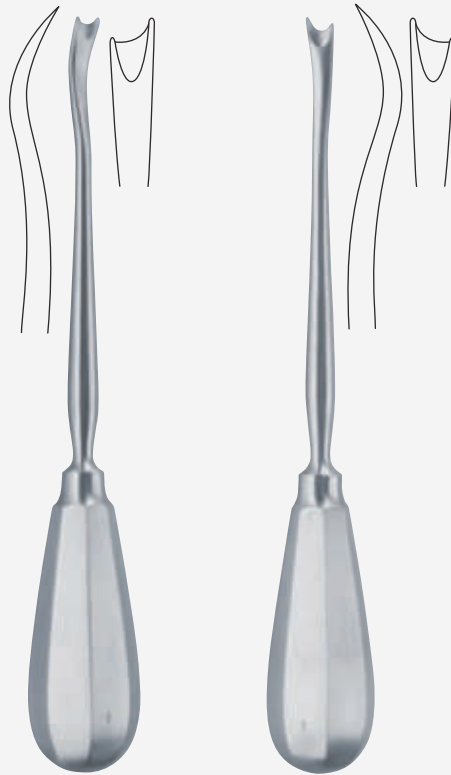

Kanadisches Modell

12-885-20

Fig. 1

12-886-20

20 cm - 8"

Fig. 2



Neff

12-887-22

left  
links  
izquierda  
gauche  
sinistra



12-888-22

22 cm - 8 3/4"

right  
rechts  
derecha  
droit  
destra



Nilcon

12-889-18

18 cm - 7"





**Wixon**

12-890-23

12-891-23

12-892-23

23 cm - 9"

4.0 mmØ

4.5 mmØ

5.5 mmØ

Malleable shaft  
 Schaft biegsam  
 Tige malléable  
 Tija maleable  
 Asta malleabile



**Bunnell**

12-893-15

12-894-15

12-895-15

15 cm - 6"

Fig.1

Fig.2

Fig.3



12-896-15

12-897-15

Fig.4

Fig.5



Fischer

12-898-31

31 cm - 12 1/4"



Bunnell

12-899-23

23 cm - 9"

Tendon passer  
Sehnen durchzugs sonde  
Sonde conductrice pour tendons  
Sonda conductora de tendones  
Sonda conduttrice per tendini



Kleinert-  
Kutz

12-900-20

20 cm - 8"  
20 mm Ø

Tendon holding forceps  
 Sehnenfasszangen  
 Pinzas para coger tendones  
 Pincas pour saisir les tendons  
 Tendine tenendo forcipe

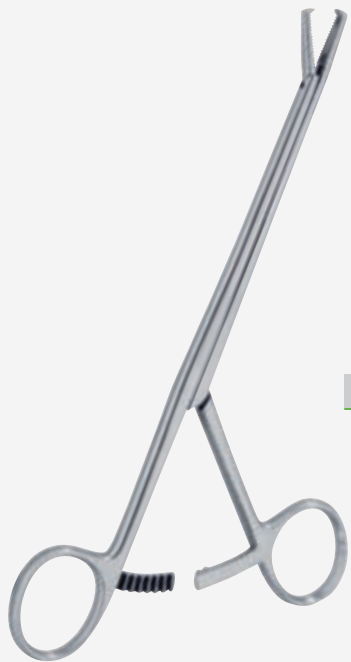

Brand

12-901-15

15 cm - 6"



12-902-19

19 cm - 7 1/2"

12-903-24

24 cm - 9 1/2"

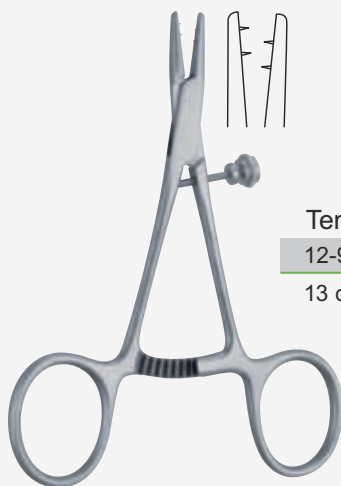

Tendon

12-904-13

13 cm - 5"



Tendon

12-905-15

15 cm - 6"



12-906-15

15 cm - 6"



Luer

12-907-15

Fig.1  
15 cm - 6"



12-908-15

Fig.2  
15 cm - 6"

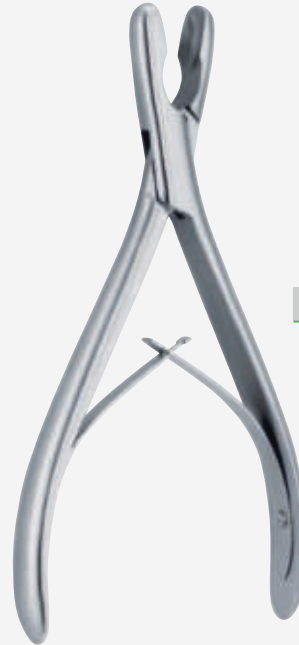

Luer

12-909-17

17 cm - 6 3/4"



12-910-17

17 cm - 6 3/4"



Blumenthal

12-911-15

15.5 cm - 6"  
Fig.1



12-912-15

15.5 cm - 6"  
Fig.2

12-913-15

15.5 cm - 6"  
Fig.3



Jansen

12-914-18

18 cm - 7"  
Fig.1



12-915-18

18 cm - 7"  
Fig.2



Mini-  
Friedmann  
12-916-12  
12 cm - 4 3/4"



Friedmann  
12-917-14  
14 cm - 5 1/2"

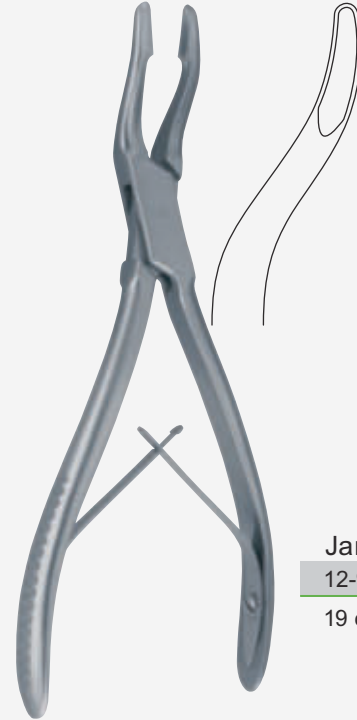

Jansen  
12-918-19  
19 cm - 7 1/2"



Adson  
12-919-20  
20 cm - 8"



Bacon  
12-920-21  
21 cm - 8 1/4"



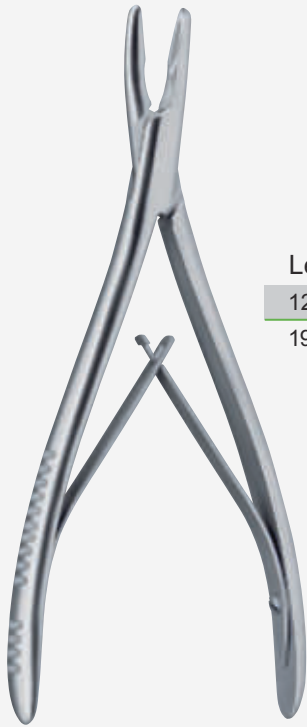

**Lempert**

12-921-19

19 cm - 7 1/2"



12-922-19

19 cm - 7 1/2"

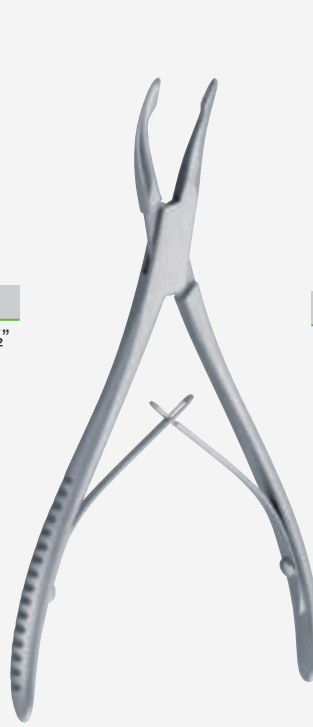

**Stellbrink**

12-923-17

17.5 cm - 7"

slightly curved

leicht gebogen

ligeramente curvada

légèrement courbe

legermente curvata

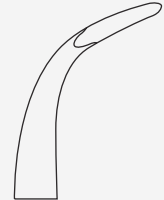

12-924-17

17.5 cm - 7"

strongly curved

stark gebogen

fuertemente curvada

très courbe

fortemente curvata



**Olivecrona**

12-925-20

20.5 cm - 8"

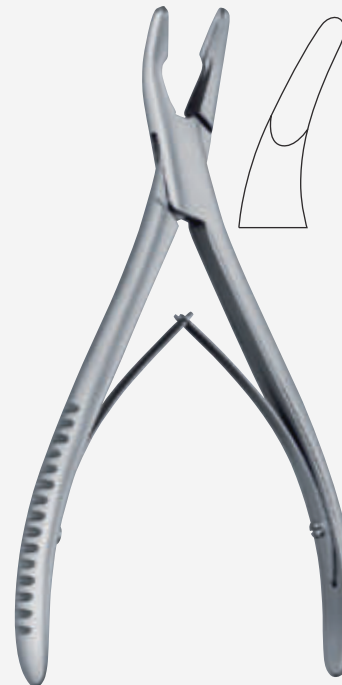

**Hartmann**

12-926-17

17.5 cm - 7"



**Mead**  
 12-927-16  
 16.5 cm - 6 1/2"



**Cleveland**  
 12-928-17  
 17 cm - 6 3/4"



**Cleveland**  
 12-929-14  
 14 cm - 5 1/2"

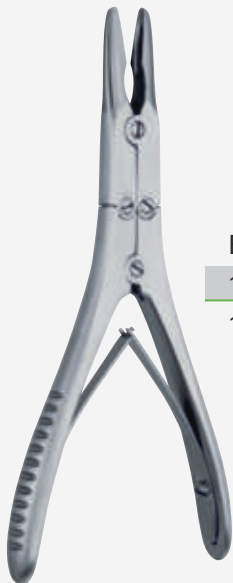

**Böhler**  
 12-930-15    12-931-15  
 15 cm - 6"    15 cm - 6"

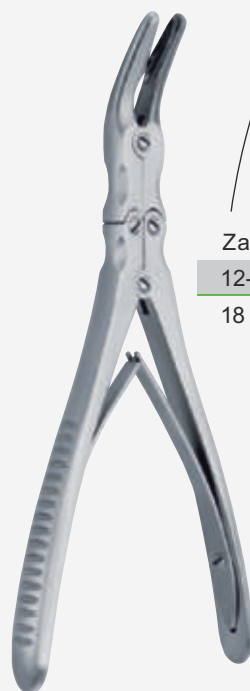

**Zaufal-Jansen**  
 12-932-18  
 18 cm - 7"



**Marquardt**  
 12-933-20  
 20 cm - 8"

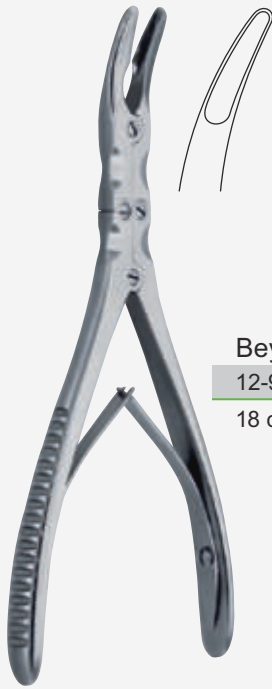

**Beyer**  
12-934-18  
18 cm - 7"



**Ruskin**  
12-935-18  
18 cm - 7"



12-936-18  
18 cm - 7"



**Mayfield**  
12-937-17  
17.5 cm - 7"



**Stille-Ruskin**

12-938-23	12-939-23
23 cm - 9"	23 cm - 9"

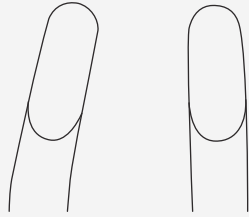

**Stille**

12-940-23	12-941-23	12-942-23
4 mm	6 mm	8 mm
23 cm - 9"	23 cm - 9"	23 cm - 9"



**Leksell**

12-943-24	12-944-24	12-945-24
4 mm	6 mm	8 mm
24 cm - 9 1/2"	24 cm - 9 1/2"	24 cm - 9 1/2"

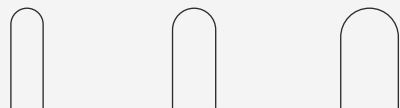

**Stille-Luer**

12-946-22	12-947-22
22 cm - 8 3/4"	22 cm - 8 3/4"

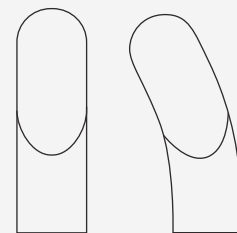



**Röttgen-  
Ruskin**  
12-948-23  
23 cm - 9"

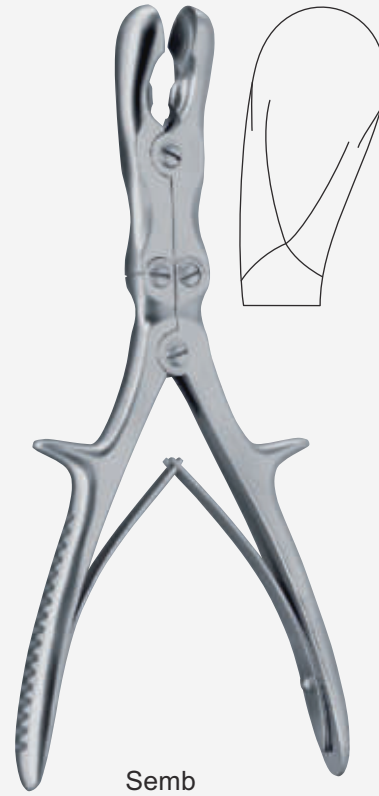

**Semb**  
12-949-24  
24 cm - 9½"

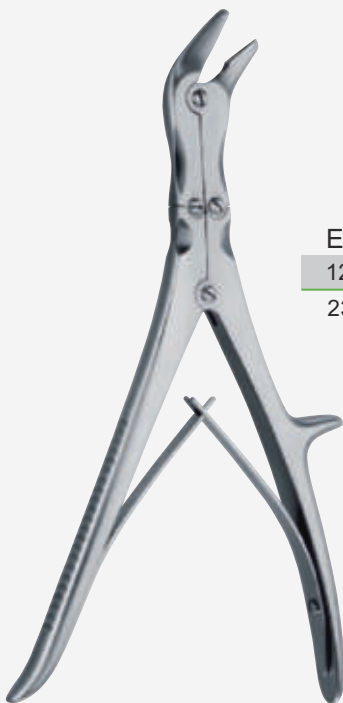

**Echlin**  
12-950-23  
23 cm - 9"



12-951-23  
23 cm - 9"

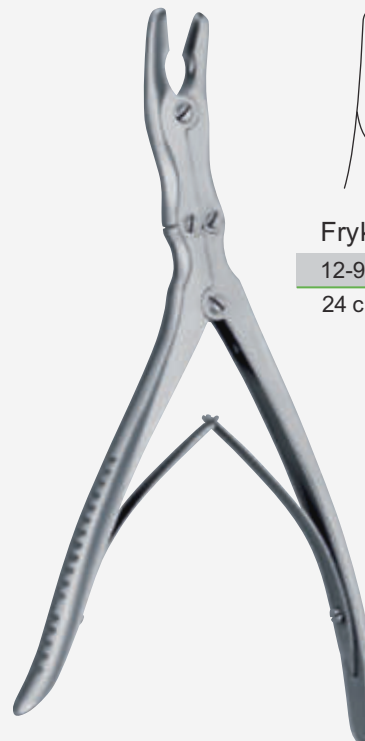

**Frykholm**  
12-952-24  
24 cm - 9½"

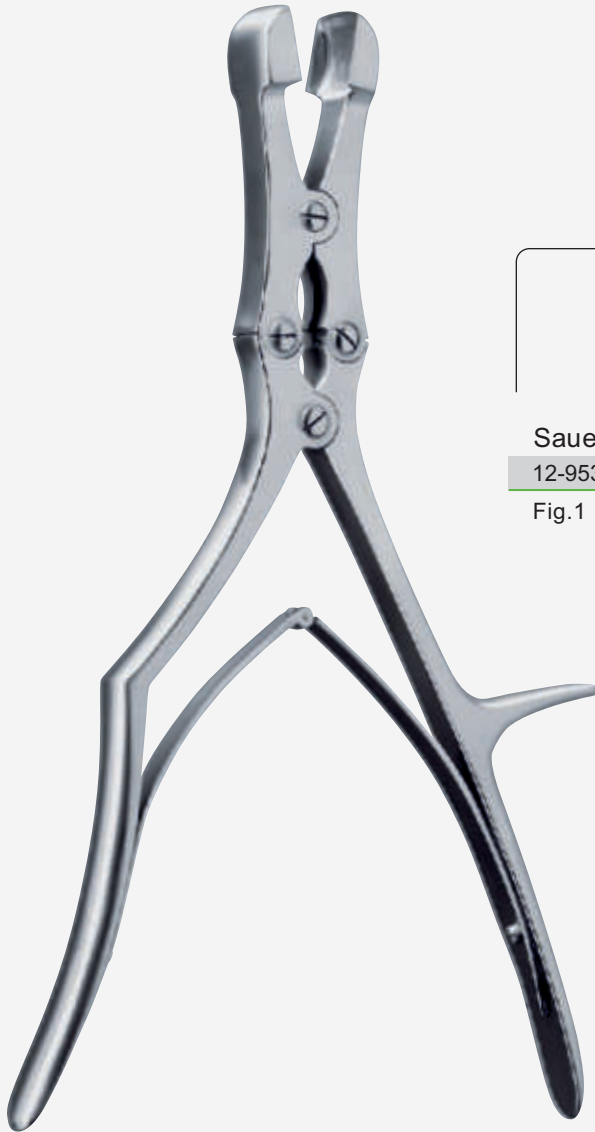

Sauerbruch

12-953-30

Fig.1

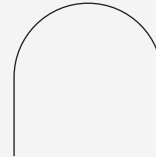

12-454-30

30 cm - 12"

Fig.2

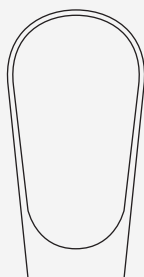

Luer-Stille

12-955-27

Fig.1

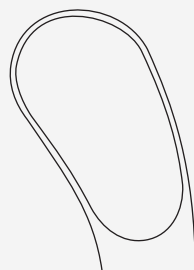

12-956-27

27 cm - 10 3/4"

Fig.2





Syvert

12-250-08

36 cm - 14 1/4"  
8 mm

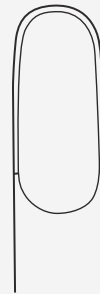

12-250-12

36 cm - 14 1/4"  
12 mm

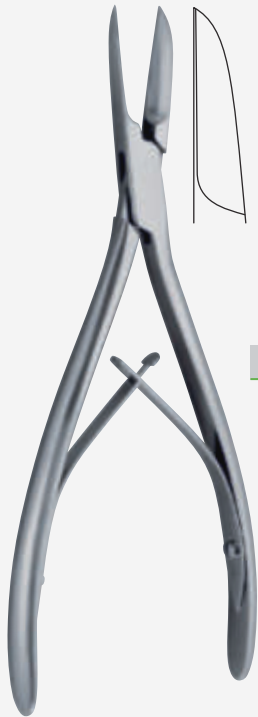

**Cottle-  
Kazanjan**  
 12-957-19  
 19 cm - 7 1/2"

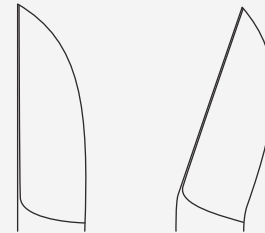

**Liston**

12-958-14	12-959-14	14 cm - 5 1/2"
12-958-17	12-959-17	17 cm - 6 3/4"
12-958-19	12-959-19	19 cm - 7 1/2"
12-958-22	12-959-22	22 cm - 8 3/4"

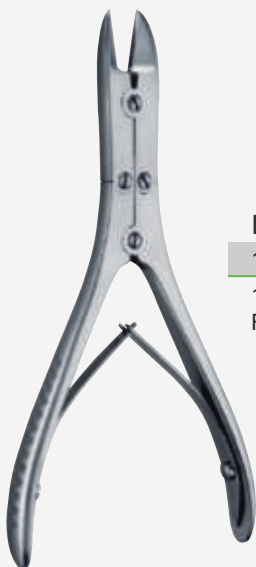

**Bohler**  
 12-960-16  
 15 cm - 6"  
 Fig. 1



12-961-16  
 15 cm - 6"  
 Fig. 2



**Ruskin-  
Liston**

12-962-18  
 18.5 cm - 7 1/4"  
 Fig. 1



12-963-18  
 18.5 cm - 7 1/4"  
 Fig. 2



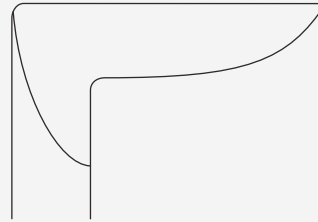

Stille-Liston

12-964-27

Fig. 1

12-965-27

Fig. 2

12-966-27

Fig. 3

27 cm - 10 3/4"

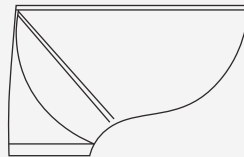

Semb

12-967-24

24 cm - 9 1/2"

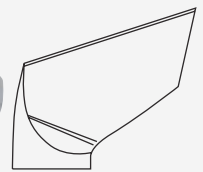

Liston-Key Horsley

12-968-27

27 cm - 10 3/4"

Bone holding clamps – Bone holding forceps  
 Knochenhalteklammern – Knochenhaltezangen  
 Pinzas porta huesos – Pinzas para huesos  
 Daviers à os – Daviers porte-os  
 Bone in possesso di pinze - pinze d'osso



Gerster-Lowmann

12-969-18	18 cm - 7"	x = 28 mm
12-969-20	20 cm - 8"	x = 35 mm
12-969-22	22 cm - 8 ¾"	x = 40 mm

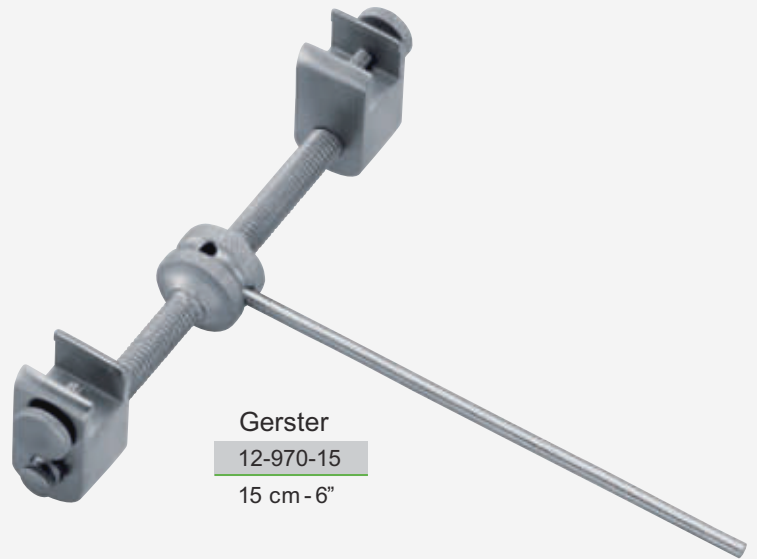

Gerster  
 12-970-15  
 15 cm - 6"

Bone holding forceps – Reposition forceps  
 Knochenhaltezangen – Repositionszangen  
 Pinzas para huesos – Pinzas para reposición  
 Daviers porte-os – Pinces de reposition  
 Tenendo pinza Bone - Riposizionare forcipe

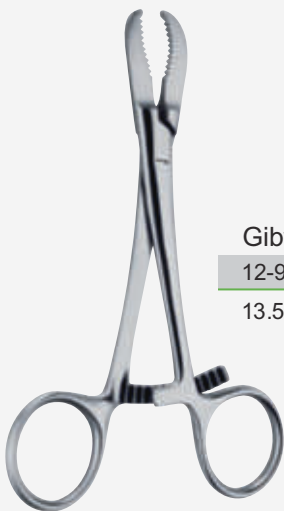

Gibway  
 12-971-13  
 13.5 cm - 5 ¼"



Lewin  
 12-972-17  
 17.5 cm - 7"

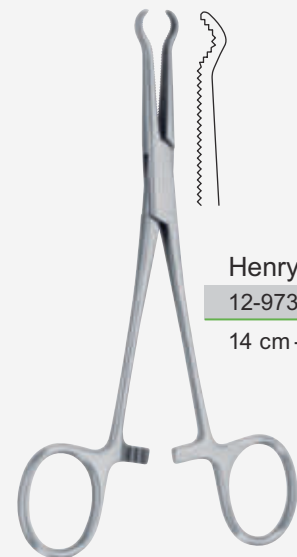

Henry  
 12-973-14  
 14 cm - 5 ½"



**Fergusson**  
12-974-21  
21 cm - 8 1/4"



**Van Buren**  
12-975-23  
23 cm - 9"



**Langenbeck**  
12-976-21  
21 cm - 8 1/4"



**Semb**  
12-977-19  
19 cm - 7 1/2"

Bone holding forceps  
 Knochenhaltezangen  
 Pinzas para huesos  
 Daviers porte-os  
 Pinza tenendo Bone

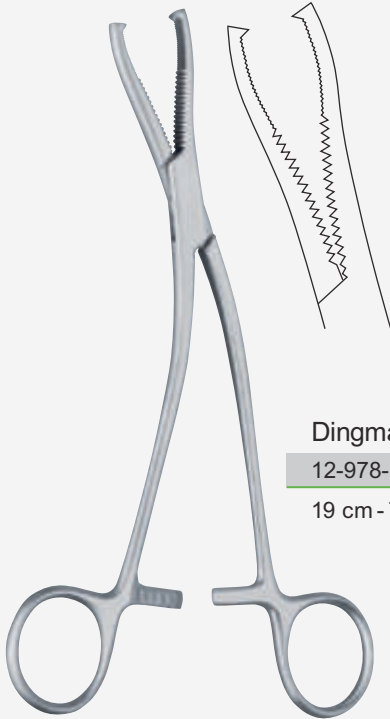

Dingmann  
 12-978-19  
 19 cm - 7 1/2"



Bare  
 12-979-20    12-980-20    20 cm - 8"

Sequesterum forceps  
 Sequesterzange  
 Pinza para Sequesterum  
 Pince pour Sequesterum  
 Pinza per Sequesterum

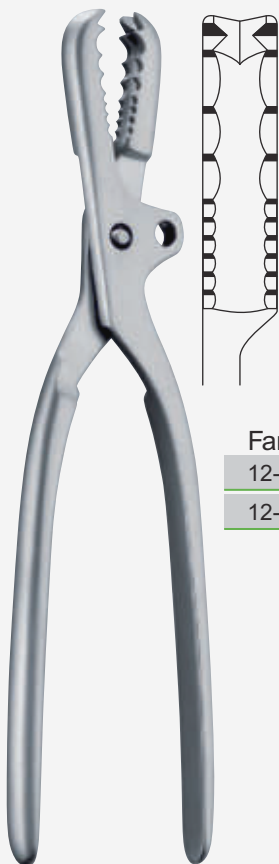

Farabeuf  
 12-981-23    23 cm - 9"  
 12-982-26    26 cm - 10 1/4"



Farabeuf-Lambotte  
 12-983-26    26 cm - 10 1/4"

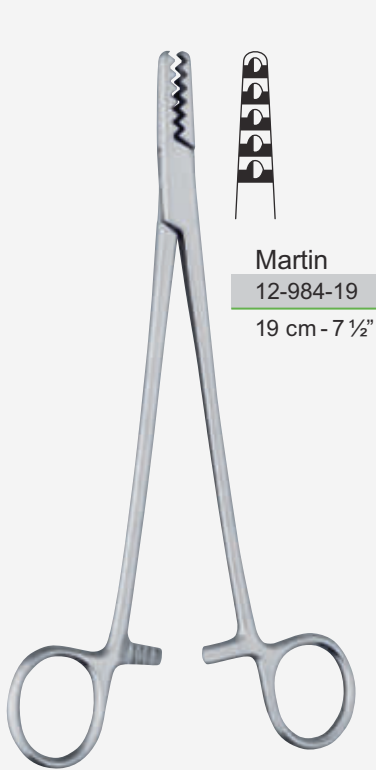

**Martin**  
12-984-19  
19 cm - 7 1/2"

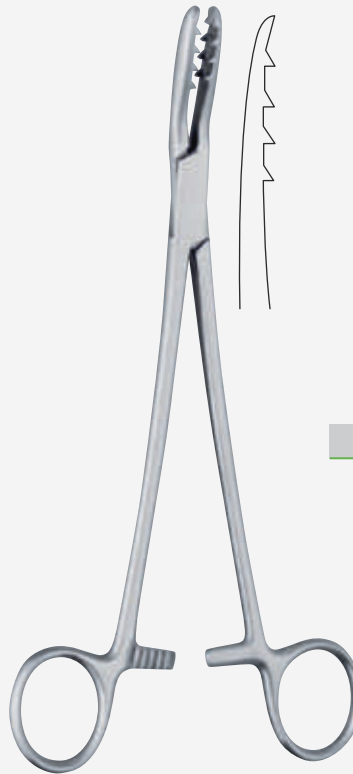

**Bircher-Ganske**

12-985-20

12-986-20

20 cm - 8"



**Hey Groves**

12-987-21 21 cm - 8 1/4" x = 6.5 mm

12-987-27 27 cm - 10 3/4" x = 7.5 mm

12-987-30 30.5 cm - 12" x = 8.5 mm

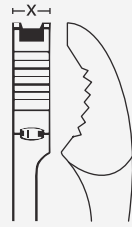

Verbrugge

12-988-17

17.5 cm - 7"  
 x = 5.0 mm

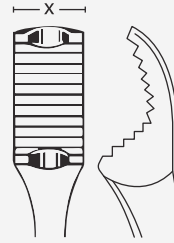

12-989-25

25 cm - 10"  
 x = 9.5 mm

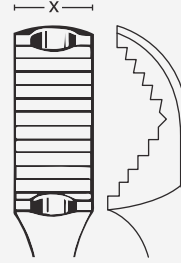

12-990-26

26 cm - 10 1/4"  
 x = 10.5 mm

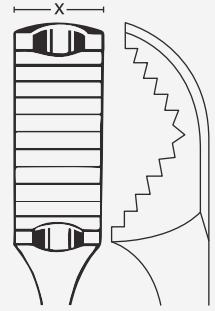

12-991-27

27 cm - 10 3/4"  
 x = 12.0 mm



Kern

12-992-17 17 cm - 6 3/4"

12-992-21 21 cm - 8 1/4"



Kern

12-993-17 17 cm - 6 3/4"

12-993-21 21 cm - 8 1/4"

Self-retaining



Lane

12-995-33 33 cm - 13"

12-995-45 45 cm - 17 3/4"



Lane

12-994-33 33 cm - 13"

12-994-45 45 cm - 17 3/4"

Self-retaining

Bone holding forceps  
 Knochenhalte­zangen  
 Pinzas para huesos  
 Daviers porte-os  
 Pinza tenendo Bone



**Lambotte**

12-996-22	22 cm - 8 3/4"
12-996-27	27 cm - 10 3/4"
12-996-30	30 cm - 12"

one jaw mobile  
 ein Maulteil beweglich  
 una boca movable  
 un mors mobile  
 una parte del morso mobile

**Lumbart**

12-997-15	15 cm - 6"	x = 2.5 mm
12-997-19	19 cm - 7 1/2"	x = 6.5 mm
12-997-24	24 cm - 9 1/2"	x = 9.5 mm
12-997-26	26 cm - 10 1/4"	x = 10.0 mm
12-997-28	28 cm - 11"	x = 11.0 mm

self-centering  
 selbstzentrierend  
 autocentrante  
 auto-centreur  
 autocentrante



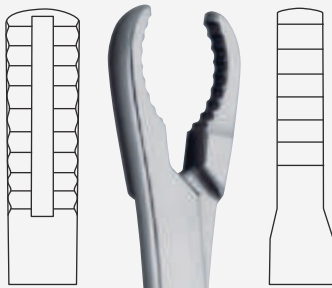

**Ulrich**

12-998-23	12-999-23	23 cm - 9"
12-998-25	12-999-25	25 cm - 9 3/4"
12-998-28	12-999-28	28 cm - 11"

angular  
kniegebogen  
acodada  
coudée  
angolata

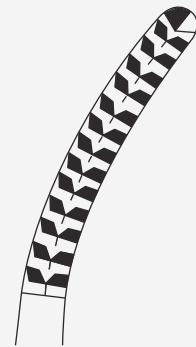

**Carl**

12-100-16	16 cm - 6 1/4"
12-100-24	24 cm - 9 1/2"



**Minipal**  
12-101-13  
13.5 cm - 5 ¼"

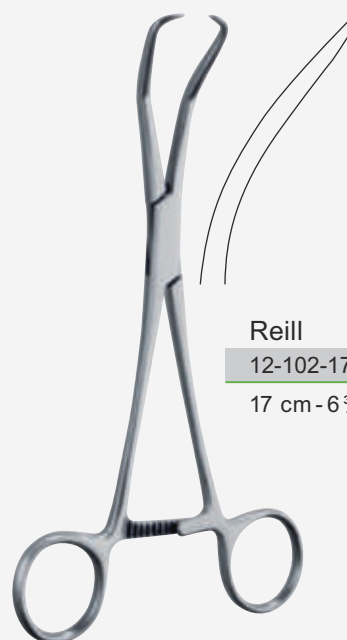

**Reill**  
12-102-17  
17 cm - 6 ¾"

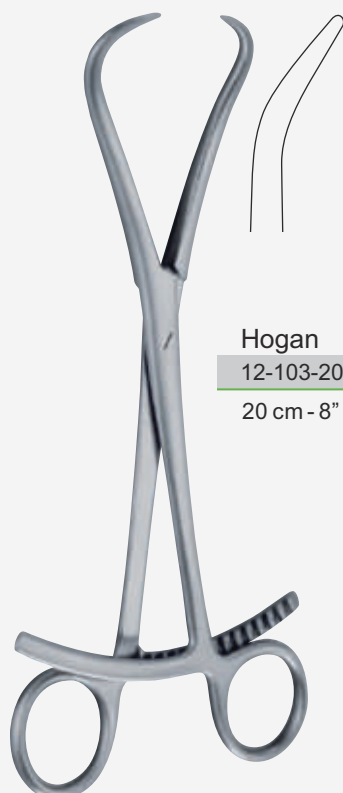

**Hogan**  
12-103-20  
20 cm - 8"



**Sadle**  
12-104-13  
13.5 cm - 5"  
for maxillary reposition  
für Kieferreposition  
para reposición mandibular  
pour reposition mandibulaire  
per reposizione mandibulare



**Haase**

12-105-16

16.5 cm - 6 1/2"

for mandibular fractures  
für Unterkieferfrakturen  
para fracturas del mandibulo  
pour fractures mandibulaires  
per fratture mandibulare



**Saddle Mini**

12-106-9

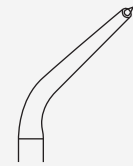

12-107-9

9.5 cm - 3 3/4"



**Patella**

12-108-18

18.5 cm - 7 1/4"



**Malleolar**

12-109-21

21 cm - 8 1/4"



Demel  
12-110-32 x = 32 mm  
12-110-45 x = 45 mm  
12-110-62 x = 62 mm  
28 cm - 11"



Demel  
12-111-28  
28 cm - 11"



**Loute**  
12-112-21  
21 cm - 8 1/4"



**Tightner**  
12-113-13  
13 cm - 5"



12-114-01	0.2 mm Ø
12-114-02	0.3 mm Ø
12-114-03	0.4 mm Ø
12-114-04	0.5 mm Ø
12-114-05	0.6 mm Ø
12-114-06	0.7 mm Ø
12-114-07	0.8 mm Ø
12-114-08	0.9 mm Ø
12-114-09	1.0 mm Ø
12-114-10	1.2 mm Ø
12-114-11	1.5 mm Ø

Bone wire, soft, in coils of 10 m  
Knochendraht, weich, in Ringen à 10 m  
Alambre de cerclaje, blando, de 10 m  
Fil de cerclage, souple, de 10 m  
Filo per ossa, morbida, anelli da 10 m



12-115-01	0.8 mmØ x280 mm
12-115-02	1.0 mmØ x 280 mm
12-115-03	1.2 mmØ x 280 mm
12-115-04	1.0 mmØ x600 mm
12-115-05	1.2 mmØ x600 mm



Bone wire with eye, soft, package of 10 pieces  
Knochendraht mit Auge, weich, Packung à 10 Stück  
Alambre de cerclaje, blando, paquete de 10 piezas  
Fil de cerclage, souple, paquet de 10 pièces  
Filo per ossa con ansa, morbida, pacchetto di 10 pezzi



**Heft**

12-116-22 22 cm - 8 3/4"

for hard wires up to 2.2 mm Ø, for soft wires up to 3 mm Ø  
 für harte Drähte bis 2.2 mm Ø, für weiche Drähte bis 3 mm Ø  
 para alambres duros hasta 2.2 mm Ø, y alambres blandos de 3 mm Ø  
 pour fils durs à diam. 2.2 mm Ø, pour fils souples à 3 mm Ø  
 per fili duri fina 2.2 mm Ø, per fili morbidi fino a 3mm Ø



**Taxon**

12-117-22 22 cm - 8 3/4"

for hard wires up to 2.2 mm Ø, for soft wires up to 2.8 mm Ø  
 für harte Drähte bis 2.2 mm Ø, für weiche Drähte bis 2.8 mm Ø  
 para alambres duros hasta 2.2 mm Ø, y alambres blandos de 2.8 mm Ø  
 pour fils durs à 2.2 mm Ø, pour fils souples à 2.8 mm Ø  
 per fili duri fina 2.2 mm Ø, per fili morbidi fino a 2.8 mm Ø



**Kilborn**

12-118-23 12-118-23 23 cm - 9"

straight curved

for hard wires up to 2.2 mm Ø, for soft wires up to 3 mm Ø  
 für harte Drähte bis 2.2 mm Ø, für weiche Drähte bis 3 mm Ø  
 para alambres duros hasta 2.2 mm Ø, y alambres blandos de 3mm Ø  
 pour fils durs à 2.2 mm Ø, pour fils souples à 3 mm Ø  
 per fili duri fina 2.2 mm Ø, per fili morbidi fino a 3 mm Ø

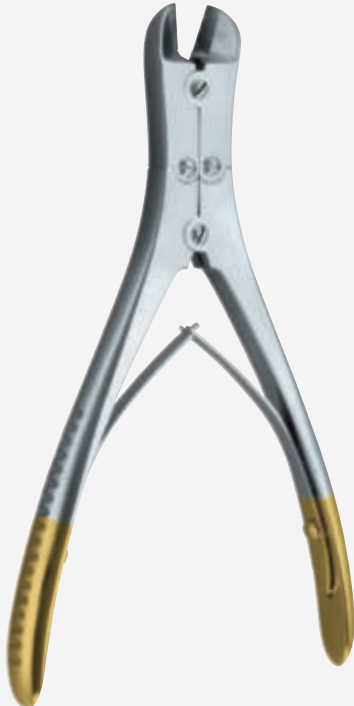

T-Cut  
Fig. 1

12-119-18 18 cm - 7"

for hard wires up to 1.5 mm Ø, for soft wires up to 2 mm Ø  
für harte Drähte bis 1.5 mm Ø, für weiche Drähte bis 2 mm Ø  
para alambres duros hasta 1.5 mm Ø, y alambres blandos de 2 mm Ø  
pour fils durs à 1.5 mm Ø, pour fils souples à 2 mm Ø  
per fili duri fina 1.5 mm Ø, per fili morbidi fino a 2 mm Ø



T-Cut  
Fig. 2

12-120-18 18 cm - 7"

for hard wires up to 1.7 mm Ø, for soft wires up to 2 mm Ø  
für harte Drähte bis 1.7 mm Ø, für weiche Drähte bis 2 mm Ø  
para alambres duros hasta 1.7 mm Ø, y alambres blandos de 2 mm Ø  
pour fils durs à 1.7 mm Ø, pour fils souples à 2 mm Ø  
per fili fina 1.7 mm Ø, per fili morbidi fino a 2 mm Ø



Gabriel

12-121-15 15 cm - 6"

for hard wires up to 1 mm Ø, for soft wires up to 1.5 mm Ø  
für harte Drähte bis 1 mm Ø, für weiche Drähte bis 1.5 mm Ø  
para alambres duros hasta 1 mm Ø, y alambres blandos de 1.5 mm Ø  
pour fils durs à 1 mm Ø, pour fils souples à 1.5 mm Ø  
per fili duri fina 1 mm Ø, per fili morbidi fino a 1.5 mm Ø



Zim

12-122-14 14.5 cm - 5 3/4"

for hard wires up to 1 mm Ø  
für harte Drähte bis 1 mm Ø  
para alambres duros hasta 1 mm Ø  
pour fils durs à 1 mm Ø  
per fili duri fino a 1 mm Ø



Haanna

12-122-18

18.5 cm - 7 1/4"

soft Ø 2.5mm  
hard Ø 1.5mm



**Ultramake**

12-123-57 57 cm - 22 1/2"

for Kirschner wires and Steinmann pins up to 6 mm Ø  
 für Kirschner Drähte und Steinmann Nägel bis 6 mm Ø  
 para agujas de Kirschner y clavos de Steinmann hasta 6 mm Ø  
 pour des broches Kirschner et clous Steinmann à 6 mm Ø  
 per fili Kirschner e chiodi Steinmann fino a 6 mm Ø



**Mochi**

12-124-18 18.5 cm 7 1/4"

Kopfschneider, durchbohrt für harte Drähte bis 1.6 mm Ø  
 Wire cutting forceps for hard wires up to 1.6 mm Ø  
 Pince coupante pour fils durs à 1.6 mm Ø  
 Alicates para alambres duros hasta 1.6 mm Ø  
 Pinza taglia fili per fili duri fino a 1.6 mm Ø



soft Ø 2mm

hard Ø 2mm

**Gravity**

12-125-16

16 cm - 6 1/4"



**Lionman**

12-125-26 26 cm - 10 1/4"

for hard wires up to 3 mm Ø  
 für harte Drähte bis 3 mm Ø  
 para alambres duros hasta 3 mm Ø  
 pour fils durs à 3 mm Ø  
 per fili duri fino a 3mm Ø





Passor

12-126-13 13 cm - 5"

12-126-18 18 cm - 7"



Flatone

12-127-14 14 cm - 5 1/2"

12-127-17 17 cm - 6 3/4"



Flat pro

12-128-05

12-128-05

18 cm - 7"

12-129-05 x = 5 mm

12-129-07 x = 7 mm

18 cm - 7"



Twison

12-130-22 22 cm - 8 3/4"

Grip-Zange, kombiniert mit TC-Schneider  
Grip forceps, combined with TC-Cutter  
Pince grip, avec partie coupante TC  
Pinza grip, con parte cortante TC  
Pinza grip, con morso tagliente a TC



Gripper

12-131-19 19 cm - 7 1/2"

Technische Zange, verstellbar  
Technical forceps, adjustable  
Pince technique, ajustable  
Pinza tecnica, ajustable  
Pinza tecnica, regolabile

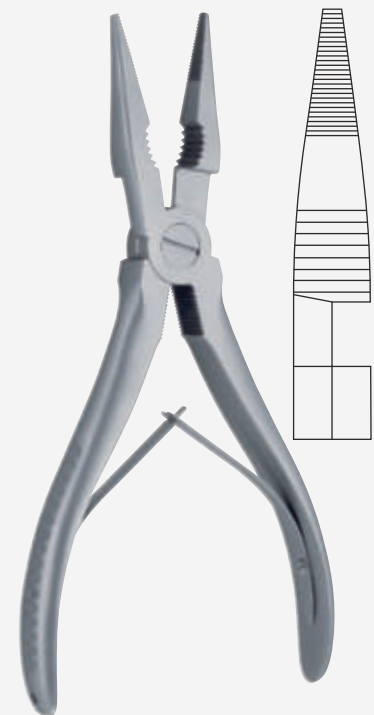

Combi

12-132-17

17 cm - 6 3/4"



**Arom - Fig. 1**

12-133-18

18.5 cm - 7 1/4"

Wire bending forceps  
 Drahtbiegezange  
 Pinza para torcer  
 Pince à couder  
 Pinza per piegare



**Fig. 2**

12-134-18

18.5 cm - 7 1/4"

Flat nose plier, parallel grip, incorporated cutter, for hard wires up to 1.6 mm Ø  
 Flachzange mit Seitenschneider, parallelfassend, für harte Drähte bis 1.6 mm Ø  
 Pinza para torcer con corte lateral, para alambres hasta 1.6 mm Ø  
 Pince à couder avec coupe latéral, pour des fils durs à de 1.6 mm Ø  
 Pinza, morso piatto parallelo e taglia fili laterale fino a 1.6 mm Ø



**Fixton**

12-135-18

18 cm - 7"

12-135-20

20 cm - 8"

12-135-24

24 cm - 9 1/2"

Locking plier  
 Feststellzange  
 Pinza de fijar  
 Pince à caler  
 Pinza bloccante



**Fixton - Advanced**

12-136-20

20 cm - 8"

Plattenbiegezange für Knochenplatten bis 2.7 mm Stärke  
 Plate bending plier for plates up to 2.7 mm  
 Pince à couder pour des plaques de 2.7 mm  
 Pinza para torcer, placas hasta 2.7 mm  
 Pinza piega placche fino a 2.7 mm

12-137-24

24 cm - 9 1/2"

Plattenbiegezange für Knochenplatten bis 4 mm Stärke  
 Plate bending plier for plates up to 4 mm  
 Pince à conder pour des plaques de 4 mm  
 Pinza para torcer, para placas hasta mm 4  
 Pinza piega placche fino a 4 mm



Mayor

12-138-01 22 cm - 8 3/4"

12-138-02 25 cm - 9 3/4"

12-138-03 30 cm - 12"

Locking plier

Extension bows  
 Extensionsbügel  
 Estribos para extensión  
 Etriers pour extension  
 Archi di estensione



**Bow**

12-139-18 18 cm - 7"

Wire strainer for Kirschner wires  
 Spannschlüssel für Kirschner Drähte  
 Tensor para agujas de Kirschner  
 Tendeur pour fils de Kirschner  
 Chiave per estensione di fili Kirschner

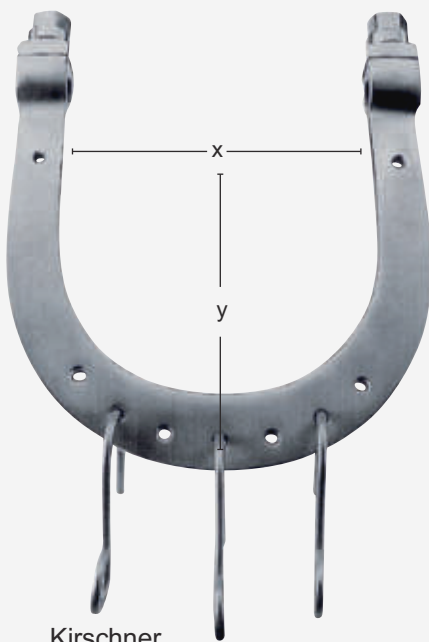

**Kirschner**

12-140-01	x = 95 mm	y = 70 mm
12-140-02	x = 100 mm	y = 100 mm
12-140-03	x = 120 mm	y = 120 mm
12-140-04	x = 155 mm	y = 155 mm
12-140-05	x = 200 mm	y = 155 mm

with 3 traction hooks  
 mit 3 Zughaken  
 con 3 ganchos de tracción  
 avec 3 crochets d'attelage  
 con 3 ganci di trazione



**Kirschner**

12-141-13	x = 130 mm
12-141-18	x = 185 mm
12-141-22	x = 220 mm

with 3 traction hooks  
 mit 3 Zughaken  
 con 3 ganchos de tracción  
 avec 3 crochets d'attelage  
 con 3 ganci di trazione

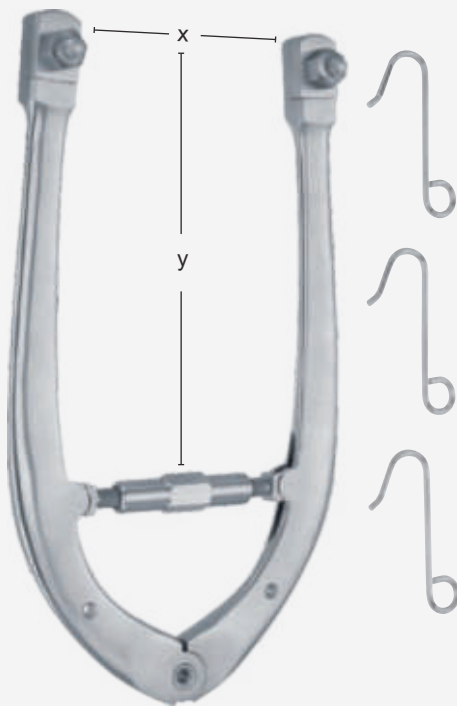

**Kirschner**

12-142-18 x = 180 mm y = 100 mm

12-142-27 x = 270 mm y = 160 mm

with 3 traction hooks  
mit 3 Zughaken  
con 3 ganchos de tracción  
avec 3 crochets d'attelage  
con 3 ganci di trazione

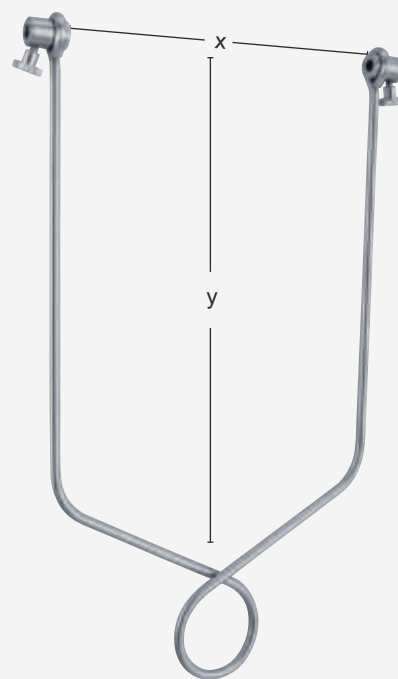

**Bohler**

12-143-01 x = 75 mm y = 90 mm

12-143-02 x = 90 mm y = 160 mm

12-143-03 x = 110 mm y = 210 mm

12-143-04 x = 150 mm y = 210 mm



**Key**

12-144-19 19 cm - 7 1/2"

14 mm / 17 mm  
Wrench  
Gabelschlüssel  
Llave de tuercas  
Clé de serrage  
Chiave per madreviti



Percy

12-145-22

Handles detachable, simple pattern  
Griffe abnehmbar, einfaches Modell  
Mango desmontable, modelo simple  
Manches à détacher, modèle simple  
Manici demontabili, modello semplice



Comprimeter

12-146-22

Consisting of arm and upper thigh cuff,  
manometer calibrated up to 700 mm Hg, with metal pump  
Komprimeter, bestehend aus Arm- und Oberschenkelmanschette,  
Manometer justiert bis 700 mm Hg und Metallpumpe  
Comprímetro, se compuesto de brazalete para brazo y muslo,  
manómetro calibrado hasta 700 mm Hg, con bomba metálica  
Comprimètre se composant du brassard pour bras et cuisse,  
manomètre calibré jusqu'à 700 mm Hg, avec pompe métallique  
Comprimeter, composto da torniquete, due bracciali e pompa d'aria  
e manometro graduato fino a 700mm Hg

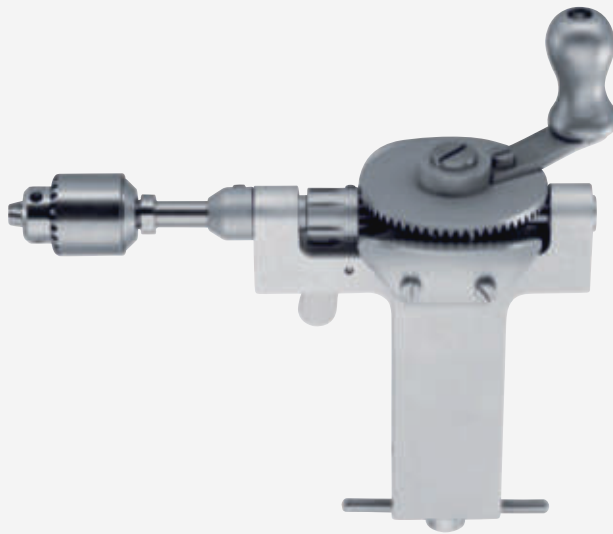

**Bunell**

12-147-16 16 cm - 6 1/4"

Opening up to 4 mm Ø  
Öffnung bis 4 mm Ø  
Apertura hasta 4 mm Ø  
Ouverture jusqu'à 4 mm Ø  
Apertura fino à 4 mm Ø

Light metal housing  
Leichtmetallgehäuse  
Carcasa en metal ligero  
Carcasse en métal léger  
In scatola di alluminio  
Longitudinally cannulated  
Längsdurchbohrt  
Taladrado longitudinalmente  
À perforation axiale  
Forato longitudinalmente

12-148-16

Spare key  
Ersatzschlüssel  
Llave de recambio  
Clé de réchange  
Chiave di ricambio



**Ralk**

12-149-16

16 cm - 6 1/4"

Opening up to 6.35 mm Ø  
Öffnung bis 6,35 mm Ø  
Apertura hasta 6.35 mm Ø  
Ouverture jusqu'à 6.35 mm Ø  
Apertura fino à 6.35 mm Ø

Light metal housing  
Leichtmetallgehäuse  
Carcasa en metal ligero  
Carcasse en métal léger  
In scatola di alluminio  
Longitudinally cannulated  
Längsdurchbohrt  
Taladrado longitudinalmente  
À perforation axiale  
Forato longitudinalmente



Stille

12-150-20  
 20 cm - 8"

12-150-00 complete with 9 twist drills (Fig. 1 – Fig. 9)

Consisting:

- |           |                        |
|-----------|------------------------|
| 12-150-20 | Drill, 20 cm / 8'      |
| 12-150-01 | Bur, Fig. 1, 2.5 mm Ø  |
| 12-150-02 | Bur, Fig. 2, 3.0 mm Ø  |
| 12-150-03 | Bur, Fig. 3, 3.5 mm Ø  |
| 12-150-04 | Bur, Fig. 4, 4.0 mm Ø  |
| 12-150-07 | Bur, Fig. 7, 8.0 mm Ø  |
| 12-150-08 | Bur, Fig. 8, 12.0 mm Ø |
| 12-150-09 | Bur, Fig. 9, 16.0 mm Ø |



12-151-01  
 Fig.1  
 2.5 mmØ



12-152-02  
 Fig.2  
 3.0 mmØ



12-153-03  
 Fig.3  
 3.5 mmØ



12-154-04  
 Fig.4  
 4.0 mmØ



12-155-07  
 Fig7  
 8.0 mm Ø



12-156-08  
 Fig.8  
 12.0 mm Ø



12-157-09  
 Fig.9  
 16.0 mm Ø



12-158-10  
 Fig.10  
 1.0 mmØ



12-159-11  
 Fig.11  
 1.5 mmØ



12-160-12  
 Fig.12  
 2.0 mmØ





Jacobs

12-161-28

28 cm - 11"

Opening up to 6.35 mm Ø  
Öffnung bis 6,35 mm Ø  
Apertura hasta 6.35 mm Ø  
Ouverture jusqu'à 6.35 mm Ø  
Apertura fino à 6.35 mm Ø



Viva

12-162-00

Opening up to 6.35 mm Ø  
Öffnung bis 6,35 mm Ø  
Apertura hasta 6.35 mm Ø  
Ouverture jusqu'à 6.35 mm Ø  
Apertura fino à 6.35 mm Ø

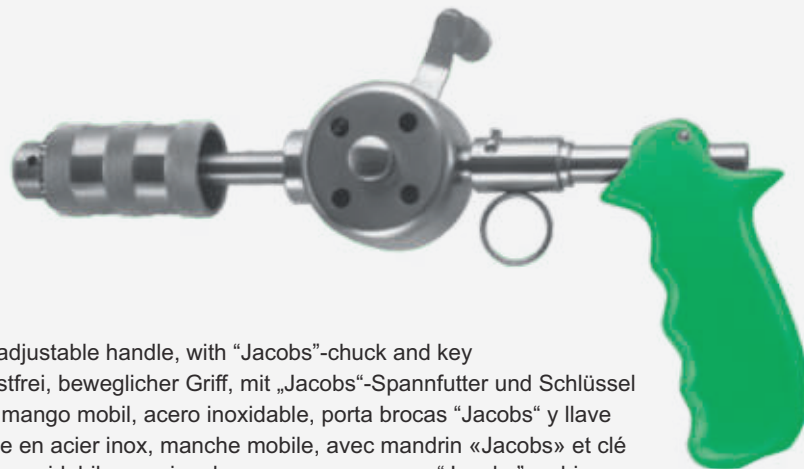

Joanna

12-163-28

28 cm - 11"

Hand drill, stainless, adjustable handle, with "Jacobs"-chuck and key  
Handbohrapparat, rostfrei, beweglicher Griff, mit „Jacobs“-Spannfutter und Schlüssel  
Taladradora a mano, mango mobil, acero inoxidable, porta brocas "Jacobs" y llave  
Perceuse mécanique en acier inox, manche mobile, avec mandrin «Jacobs» et clé  
Perforatore a mano, inossidabile, manico da muovere, con morso "Jacobs" e chiave

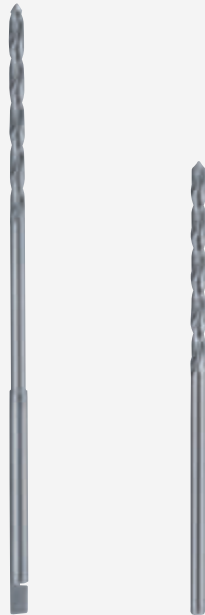

Drill

12-164-01	12-165-01	1.0 mm Ø
12-164-02	12-165-02	1.5 mm Ø
12-164-01	12-165-03	2.0 mm Ø
12-164-02	12-165-04	2.5 mm Ø
12-164-05	12-165-05	2.8 mm Ø
12-164-03	12-165-06	3.0 mm Ø
12-164-04	12-165-07	3.2 mm Ø
12-164-05	12-165-08	3.5 mm Ø
12-164-06	12-165-09	4.0 mm Ø
12-164-07	12-165-10	5.0 mm Ø
12-164-08	12-165-11	6.0 mm Ø
12-164-09	12-165-12	7.0 mm Ø

AOshank  
 AO Schaft  
 Connector AO  
 Raccord AO  
 Attaco AO

Round shank  
 Rundschaft  
 Tija redonda  
 Tige ronde  
 Asta rotondo

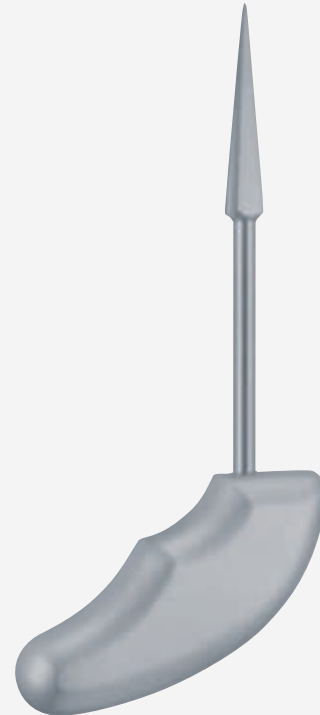

Perthes - Fig. 1

12-166-18	18 cm - 7"
12-166-21	21 cm - 8 1/4"



Fig. 2

12-167-14

14 cm - 5 1/2"



Fig. 3

12-168-14

14 cm - 5 1/2"



Micro – Neurosurgery  
Mikro – Neurochirurgie  
Micro – Neurocirugía  
Micro – Neurochirurgie  
Micro – Neurochirurgia

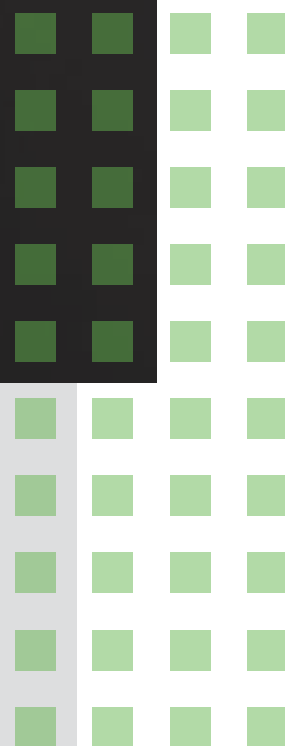

Cervical traction tongs  
 Schädelhalter  
 Pinzas de traccion cranial  
 Pinces de traction crânienne  
 Pinze trazione cervicale

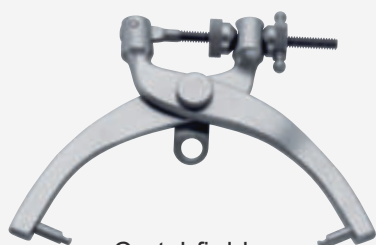

Crutchfield  
 13-700-00



13-701-00  
 3.5 mmØ



13-702-00  
 5.0 mmØ



Crutchfield  
 13-703-00



Cervical Tong  
 13-704-00

large type, cervical traction tongs – pins adjustable no drilling to be done  
 grosses Modell, für Extension der Halswirbel – kein Vorbohren erforderlich – Dorne verstellbar  
 modelo grande, distractor cervical – espigas ajustables sin necesidad de trepanar  
 modèle large, distracteur cervicale – poinçons ajustables pas de perçage nécessaire  
 modello grande, distrattore cervicale, pin ajustabili, non necessita di perforare, regolabili

13-705-00

Spare pin  
 Ersatzdorn  
 Pivote de cambio  
 Goupille de rechange  
 Punta di ricambio



Wrench  
 13-706-00

Wrench, double-ended  
 Gabelschlüssel, doppelendig  
 Llave de tuercas  
 Clé de fixation,  
 Chiave



Drill Handle

13-707-27 27 cm - 10 3/4"



13-708-27

Extension piece  
Verlängerungsstück  
Pieza de prolongación  
Pièce d'extension  
Pezzo di prolungazione



13-709-01

Fig.1  
9 mm Ø



13-710-02

Fig.2  
14 mm Ø



13-711-03

Fig.3  
16 mm Ø



13-712-04

Fig.4  
22 mmØ



Cushing  
13-713-04

Fig.5  
14 mm Ø



McKenzie  
13-714-04

Fig.6  
13 mmØ

**Hudson**

13-707-01	Complete set consisting:
13-707-27	Drill handle
	4 twist drills (Fig. 1 to Fig. 4)

**Hudson**

13-707-02	Complete set consisting:
13-707-27	Drill handle
	6 twist drills (Fig. 1 to Fig. 6)
	1 extension piece



De Martel

13-717-33

33 cm - 13"



Adson

13-715-15 15 cm - 6"



De Vibiss

13-716-21 21 cm - 8 1/4"

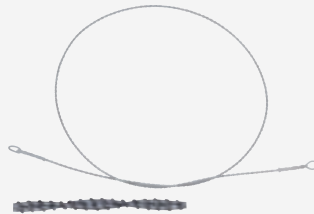

Olivecrona

13-718-30 30 cm - 12"

13-718-40 40 cm - 16"

13-718-50 50 cm - 20"

13-718-60 60 cm - 23 1/2"

13-718-70 70 cm - 27 1/2"

6 wires twisted  
 6-teilig  
 6 alambres torcidos  
 6 fils tordus  
 6 fili attorcigliati

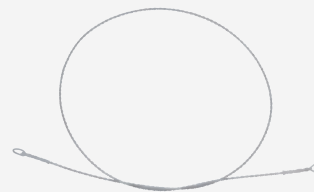

Gigli

13-719-30 30 cm - 12"

13-719-40 40 cm - 16"

13-719-50 50 cm - 20"

6 wires twisted  
 6-teilig  
 6 alambres torcidos  
 6 fils tordus  
 6 fili attorcigliati



Gigli

13-720-00

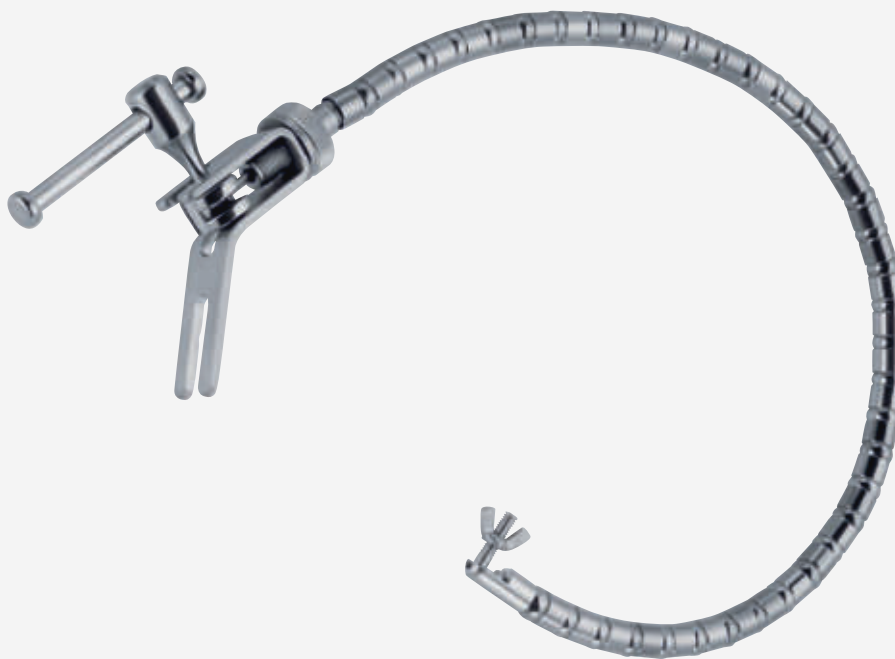

### Leyla

13-721-00

Brain retractor self-retaining, with 1 flexible arm, complete, consisting of: fixation base for 1 flexible arm, flexible arm only, support for flat brain spatulas

Selbsthaltender Hirnretraktor, flexibel mit

1 Spannarm, komplett, bestehend aus:

Fixierungsvorrichtung für 1 Spannarm, Spannarm und Spatelhalter für flache Spatel

Separador cerebral autostatico, 1 brazo flexible con soporte, completo con brazo y soporte para spatulas llanas

Retracteur cérébrale autostatique, flexible avec 1 tendeur, complét avec support pour 1 tendeur, tendeur et porte-spatule pour spatules plates

Retratore celebrale autostatico, flessibile

Completo, contiene: supporto di fissaggio per un braccio, 1 braccio flessibile con supporto di fissaggio per spatole piatte

### Leyla

13-722-00

Brain retractor self-retaining, with 2 flexible arms, complete, consisting of: fixation base for 2 flexible arms, 2 flexible arms, 2 supports for flat brain spatulas

Selbsthaltender Hirnretraktor, flexibel mit

2 Spannarmen, komplett, bestehend aus:

Fixierungsvorrichtung für 2 Spannarme, 2 Spannarme und 2 Spatelhalter für flache Spatel

Separador cerebral autostatico, 2 brazos flexibles con soporte, completo con brazos y soporte para 2 spatulas llanas

Retracteur cérébrale autostatique, flexible avec 2 tendeurs, complét avec supports pour 2 tendeurs, 2 tendeurs et 2 portes-spatule pour spatules plates

Retratore celebrale autostatico, flessibile con

2 bracci completi, contiene: supporto di fissaggio per bracci per 2 spatole piatte



Leyla

13-723-00

Fixation base only, holding 2 flexible arms  
 Fixierungsvorrichtung allein, für 2 Spannarme  
 Soporte solo para 2 brazos de separador  
 Support seul pour 2 tendeurs  
 Supporto di fissaggio per 2 bracci, solo

13-724-00

Fixation base only, holding 1 flexible arm  
 Fixierungsvorrichtung allein, für 1 Spannarm  
 Soporte solo para 1 brazo de separador  
 Support seul pour 1 tendeur  
 Supporto di fissaggio per 1 braccio, solo

13-725-00

Support only, for flat brain spatulas  
 Spatelhalter allein, für Flachspatel  
 Soporte solo, para spatulas planos  
 Porte-spatule seul, pour spatules plates  
 Supporto solo, per fissaggio di spatole piate

13-726-00

Support only, for brain spatulas with round shaft  
 of 4mm and 5mm Ø to fix on the flexible arm  
 Spatelhalter allein, für Spatel mit Rundschaft  
 von 4mm und 5mm Ø, zum Befestigen am Spannarm  
 Soporte solo para la fijación de spatulas  
 de 4mm y 5mm Ø al brazo  
 Porte-spatule seul pour la fixation des spatules  
 de 4mm et 5mm Ø diam  
 Supporto solo per spatole con asta tonda  
 di Ø 4mm e 5mm

13-727-00

Flexible arm only – for attaching coupling heads and  
 for fixation bases  
 Spannarm allein – zum Aufstecken auf Kupplungsköpfe  
 und Fixierungsvorrichtungen  
 Brazo flejible solo para montar sobre soportes  
 Tendeur flexible seul – pour le montage sur supports  
 et accouplements  
 Braccio flessibile solo – per il montaggio sul supporto  
 di fissaggio



Leyla

13-428-00

Brain Retractor, flexible, for one flat spatula complete, consisting of:

- Fixation Base for one flexible arm
- Flexible Arm
- Support for flat brain spatulas



Leyla

13-429-00

Brain Retractor, flexible, for two flat spatulas complete, consisting of:

- Fixation Base for two flexible arms
- 2 Flexible Arms
- 2 Support for flat brain spatulas



13-430-0

Flexible Arm

13-431-00

Spare Part

13-432-00

Wire Cable, only



Leyla  
Fig. 1

13-433-00

Fixation Base for skull mounting,  
holding one flexible arm



Leyla  
Fig. 2

13-434-00

Fixation Base for skull mounting,  
holding two flexible arms



Leyla  
Fig. 3

13-435-00

Support, only, for flat brain spatulas,  
for fixation at the flexible arm



Leyla  
Fig. 4

13-436-00

Support, only, for brain spatulas with round shaft  
up to 5.5 mm diam., for fixation at the flexible arm



Leyla  
Fig. 5

13-437-00

Fixation Base for mounting on bars up to Ø 16 mm  
for one flexible arm



Leyla

Fig. 1

13-438-00

Self-Retaining Retractor for fixation to the operation table, complete, consisting of:

- Ball and Socket Joint
- Holding Arm
- Coupling Head
- 2 Flexible Arms
- 2 Supports for flat spatulas
- Brain Spatula
- Brain Spatula



Leyla

Fig. 2

13-439-00

Self-Retaining Retractor for fixation to the operation table, without support, consisting of:

- Ball and Socket Joint
- Holding Arm
- Coupling Head, laterally open, to hold one flexible arm
- Flexible Arm



13-440-00

Holding Arm, detachable, for fixation in ball and socket joint for holding one of the coupling heads.

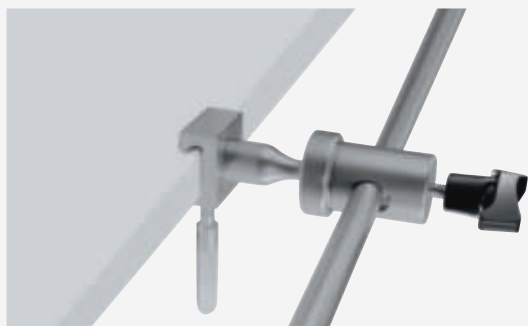

13-441-00

Ball and Socket Joint for fixation at the operating for holding arm table

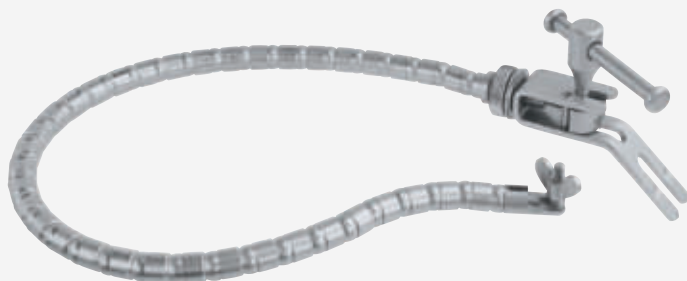

13-442-00

Flexible Arm

13-443-00

Spare Part

13-444-00

Wire Cable, only



13-445-00

Coupling Head, laterally open, to hold one flexible arm



13-446-00

Coupling Head, rotatable, to hold one flexible arm

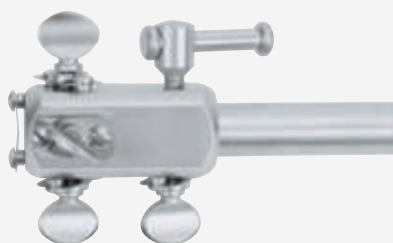

13-447-00

Coupling Head, to hold max. five flexible arms



**Ammey**

13-448-12	20 cm - 8"	12 mm
13-448-17	20 cm - 8"	17 mm
13-448-20	20 cm - 8"	20 mm
13-448-25	20 cm - 8"	25 mm
13-448-25	25 cm - 10"	25 mm

malleable



**Heifetz**

13-452-08	8 mm
13-452-11	11 mm
13-452-14	14 mm
13-452-17	17 mm

15.5 cm - 6"  
malleable



**Mod. Aachen**

13-457-07	7+8 mm
13-457-10	10+11mm
13-457-13	13+14 mm
13-457-16	16+17 mm
13-457-19	19+20 mm
13-457-22	22+25 mm

20 cm - 8"  
malleable



**Davis**

13-458-06	6 mm
13-458-10	10 mm
13-458-14	14 mm
13-458-16	16 mm
13-458-19	19 mm
13-458-25	25 mm
13-458-32	32 mm
13-458-38	38 mm

18 cm - 7"  
malleable



**Scoville**

13-459-10	10+13 mm
13-459-16	16+17 mm

20 cm - 8"  
malleable



**Cushing**

13-728-07	7 mm x 9 mm
13-728-11	11 mm x 13 mm
13-728-15	15 mm x 18 mm
13-728-18	18 mm x 22 mm

18 cm - 7"



**Olivecrona**

13-729-07	13-730-07	7 mm x 9 mm
13-729-11	13-730-11	11 mm x 13 mm
13-729-15	13-730-15	15 mm x 18 mm
13-729-18	13-730-18	18 mm x 22 mm

18 cm - 7"

convex	concave
konvex	konkav
convexa	cóncava
convexe	concave
convessa	concava

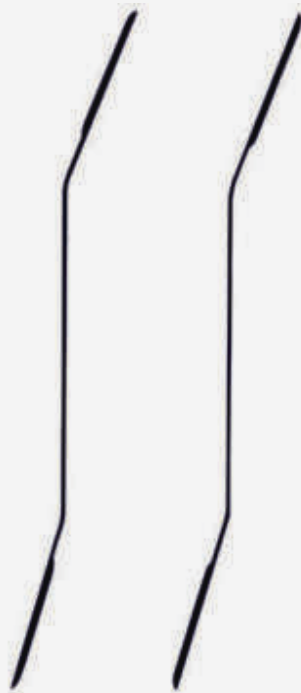

**Heifetz**

13-731-08	x = 8 mm
13-731-11	x = 11 mm
13-731-14	x = 14 mm
13-731-17	x = 17 mm
13-731-20	x = 20 mm

20 cm - 8"

malleable  
biegsam  
maleable  
malléable  
flessibile



**Casper**

13-227-04	x=4 mm
13-227-06	x=6 mm
13-227-08	x=8 mm
13-227-10	x=10 mm

247 cm - 9½"

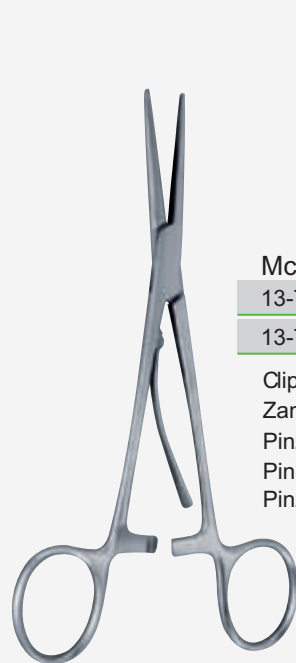

**McKenzie**

13-732-15

13-733-15

15 cm - 6"

13-732-19

13-733-19

19 cm - 7 1/2"

Clip applying forceps  
Zangen zum Anlegen der Klammern  
Pinzas para poner grapas  
Pincas pour poser des agrafes  
Pinze per mettere le agraifes



**McKenzie**

13-734-14 14.8 cm x 4 cm x 6 mm - 5 3/4" x 1 1/2" x 1/2"

Brain clip-rack for 20 clips  
Klammerblock für 20 Klammern  
Porta-grapas para 20 grapas  
Porte-agraifes pour 20 agrafes  
Supporto port'agraifes per 20 agrafes



13-735-00

100 Brain clips in plastic box  
100 Klammern im Plastikbehälter  
100 grapas en tubo de plástico  
100 agrafes dans un tube de plastique  
100 agrafes nella scatola di plastica

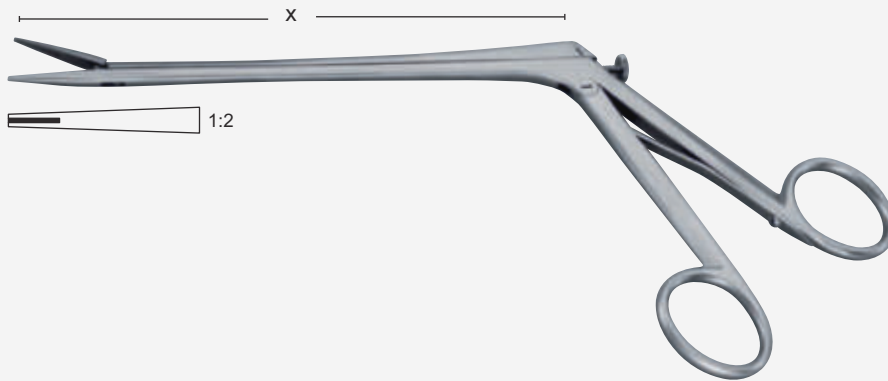

Olivecrona-Toennis  
 (Scoville)

13-736-14

x = 14 cm - 5 1/2"



Raney

13-737-15

15 cm - 6"



Clip  
 Fig. 1

13-738-15

Scalp clip "Raney"  
 Kopfhautklammer "Raney"  
 Grapa para cuero cabelludo "Raney"  
 Agrafes pour le cuir chevelu «Raney»  
 Agraffes per il cuoio capelluto „Raney“



Clip  
 Fig. 2

13-739-15

Scalp clip "Köln"  
 Kopfhautklammer „Köln“  
 Grapa para cuero cabelludo "Köln"  
 Agrafes pour le cuir chevelu «Köln»  
 Agraffes per il cuoio capelluto „Köln“



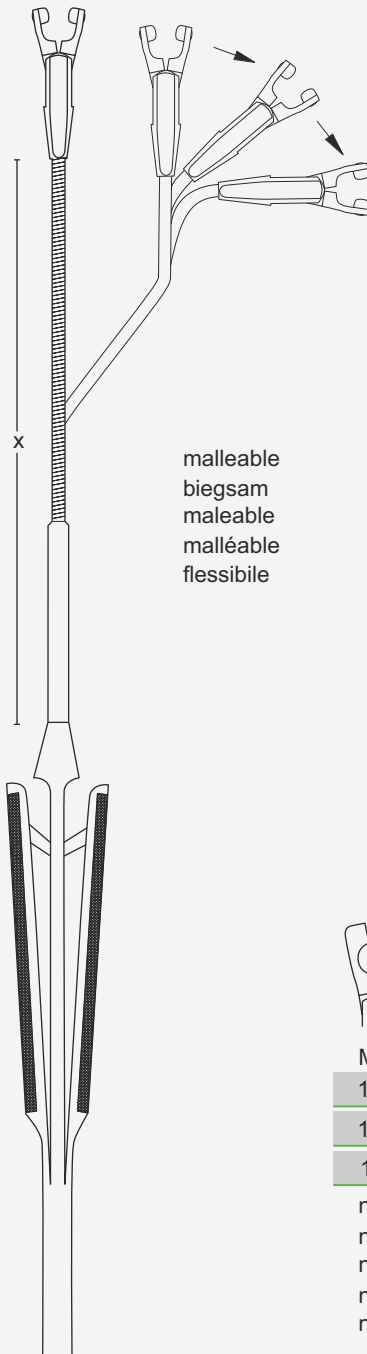

malleable  
biegsam  
maleable  
malléable  
flessibile

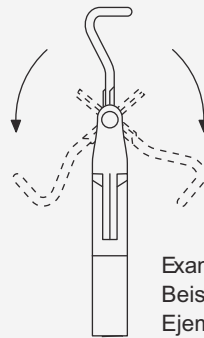

Example for rotation  
Beispiel für Drehmechanismus  
Ejemplo la rotación por  
Exemple pour la rotation  
Eempio per la rotazione



Mini

13-740-07

13-740-09

13-740-11

non rotating  
nicht drehbar  
non rotatorio  
non rotatif  
non rotativo

Standard

13-741-07

13-741-09

13-741-11



Mini

13-742-07

13-742-09

13-742-11

rotating  
drehbar  
rotatorio  
rotatif  
rotativo

Standard

13-743-07

13-743-09

13-743-11

x = 7 cm - 2 3/4"

x = 9 cm - 3 1/2"

x = 11 cm - 4 1/4"

Applying forceps for Yasargil clips  
 Anlegezangen für Yasargil Clips  
 Aplicadora para clips Yasargil  
 Pince à poser pour des clips Yasargil  
 L'applicazione di forcipe per i clip YASARGIL

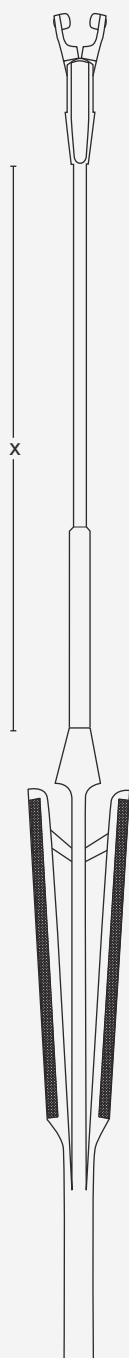

starr  
 rigid  
 rigide  
 rigido  
 rigido

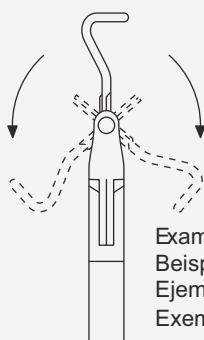

Example for rotation  
 Beispiel für Drehmechanismus  
 Ejemplo la rotación por  
 Exemple pour la rotation  
 Esempio per la rotazione



Mini

13-744-07

13-744-09

13-744-11

non rotating  
 nicht drehbar  
 non rotatorio  
 non rotatif  
 non rotativo

Standard

13-745-07

13-745-09

13-745-11



Mini

13-746-07

13-746-09

13-746-11

rotating  
 drehbar  
 rotatorio  
 rotatif  
 rotativo

Standard

13-747-07

13-747-09

13-747-11

x = 7 cm - 2 3/4"

x = 9 cm - 3 1/2"

x = 11 cm - 4 1/4"

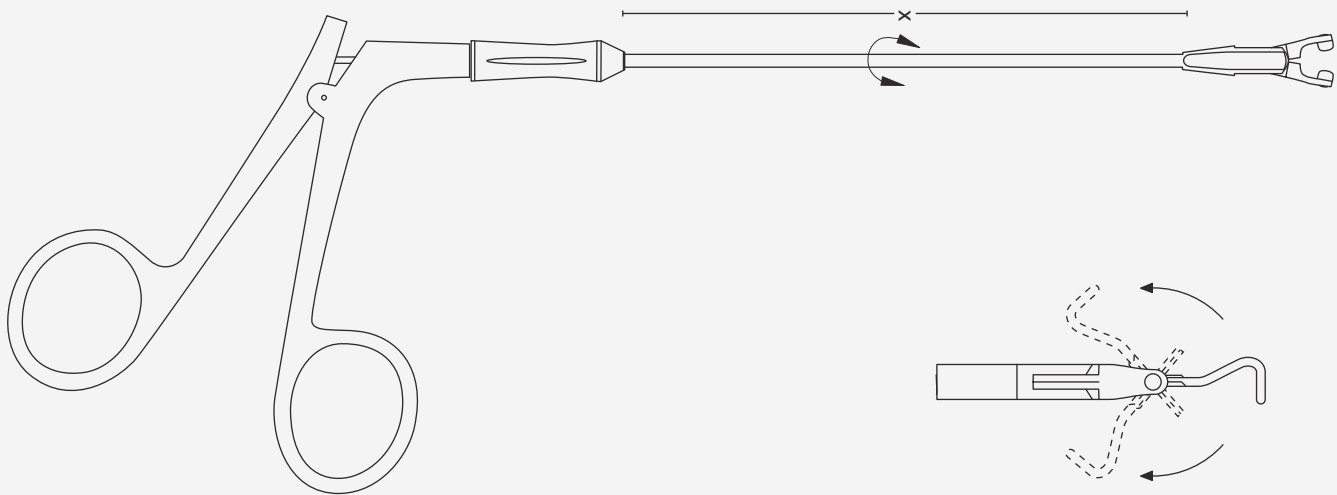

Shank rotatable  
Schaft drehbar  
Vaina giratoria  
Tige rotatif  
Asta girevole

Example for rotation  
Beispiel für Drehmechanismus  
Ejemplo la rotación por  
Exemple pour la rotation  
Esempio per la rotazione

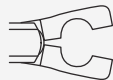

Mini	Standard
13-748-07	13-749-07
13-748-09	13-749-09
13-748-11	13-749-11
13-748-13	13-749-13

non rotating  
nicht drehbar  
non rotatorio  
non rotatif  
non rotativo

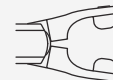

Mini	Standard	
13-750-07	13-751-07	x = 7 cm - 2 3/4"
13-750-09	13-751-09	x = 9 cm - 3 1/2"
13-750-11	13-751-11	x = 11 cm - 4 1/4"
13-750-13	13-751-13	x = 13 cm - 5"

rotating  
drehbar  
rotatorio  
rotatif  
rotativo

Applying forceps for Yasargil clips  
 Anlegezangen für Yasargil Clips  
 Aplicadora para clips Yasargil  
 Pince à poser pour des clips Yasargil  
 L'applicazione di forcipe per i clip YASARGIL



Mini	Standard
13-752-07	13-753-07
13-752-08	13-753-08
13-752-09	13-753-09
13-752-10	13-756-10

straight, with ratchet  
 gerade, mit Sperre  
 recta, con cierre  
 droit, avec verrou  
 retta, con cremagliera

Mini	Standard	
13-754-07	13-755-07	1.7 cm - 6 3/4"
13-754-08	13-755-08	1.8 cm - 7"
13-754-09	13-755-09	2.1 cm - 8 1/4"
13-754-10	13-755-10	2.3 cm - 9"

bayonett shaped, with ratchet  
 bayonett-förmig, mit Sperre  
 forma bayoneta, con cierre  
 en baionette, avec verrou  
 forma baionetta, con cremagliera

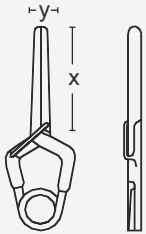

x = Jaw length  
x = Maullänge  
x = Longitud de la boca  
x = Longueur du mors  
x = Lunghezza del morso

y = max. opening  
y = max. Maulöffnung  
y = Apertura max. de la boca  
y = Ouverture max. du mors  
y = Apertura mass. del morso

gms= Pressure  
gms= Schließkraft  
gms= Presión  
gms= Force de fermeture  
gms= Sforza della chiusura

For titanium clips, please add a "T" to the reference number.

Bei Bestellung von Titan Clips, bitte der Artikelnummer ein „T“ hinzufügen.

Para clips de titanio, por favor añadir und "T" a la referencia.

Pour des clips en titane, veuillez ajouter un «T» à la référence.

Per clips in titanio, per favore aggiungete al numero d'articolo un "T".

**Yasargil-Standard**

for permanent closure, in high quality implant steel, antimagnetic  
für permanenten Verschluss, aus hochwertigem Implantatstahl, antimagnetisch  
para oclusión permanente, acero de alta calidad, antimagnetico  
pour fermeture permanente, acier de haute qualité, anti-magnétique  
per chiusura permanente, acciaio di alta qualita, antimagnetico

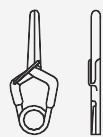

**13-756-00**  
x = 7.0 mm  
y = 6.2 mm  
gms = 150

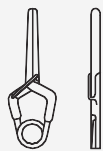

**13-757-00**  
x = 9.0 mm  
y = 7.0 mm  
gms = 180

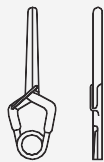

**13-758-00**  
x = 11.0 mm  
y = 7.8 mm  
gms = 180

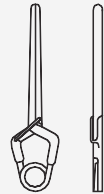

**13-759-00**  
x = 15.0 mm  
y = 9.2 mm  
gms = 200

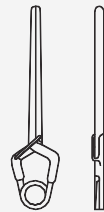

**13-760-00**  
x = 17.0 mm  
y = 10.6 mm  
gms = 200

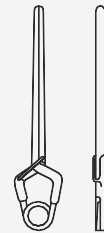

**13-761-00**  
x = 20.0 mm  
y = 11.4 mm  
gms = 200

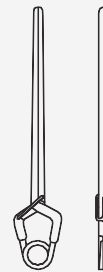

**13-762-00**  
x = 25.0 mm  
y = 13.3 mm  
gms = 200

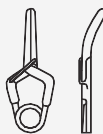

**13-763-00**  
x = 7.0 mm  
y = 6.0 mm  
gms = 150

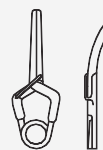

**13-764-00**  
x = 9.0 mm  
y = 6.8 mm  
gms = 180

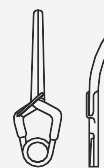

**13-765-00**  
x = 11.0 mm  
y = 7.5 mm  
gms = 180

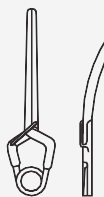

**13-766-00**  
x = 15.0 mm  
y = 8.7 mm  
gms = 200

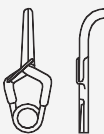

**13-767-00**  
x = 7.0 mm  
y = 5.5 mm  
gms = 150

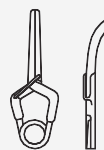

**13-768-00**  
x = 9.0 mm  
y = 6.1 mm  
gms = 180

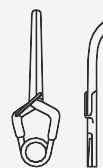

**13-769-00**  
x = 11.0 mm  
y = 6.5 mm  
gms = 180

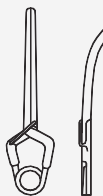

**13-770-00**  
x = 15.0 mm  
y = 7.4 mm  
gms = 200

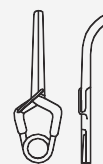

**13-771-00**  
x = 7.0 mm  
y = 5.4 mm  
gms = 180

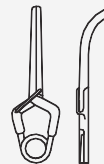

**13-772-00**  
x = 9.0 mm  
y = 5.8 mm  
gms = 180

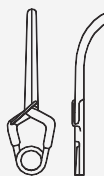

**13-773-00**  
x = 11.0 mm  
y = 6.2 mm  
gms = 180

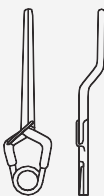

**13-774-00**  
x = 7.0 mm  
y = 7.9 mm  
gms = 200

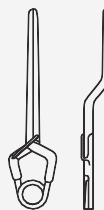

**13-775-00**  
x = 9.0 mm  
y = 8.7 mm  
gms = 200

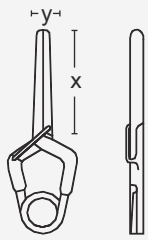

x = Jaw length  
 x = Maullänge  
 x = Longitud de la boca  
 x = Longueur du mors  
 x = Lunghezza del morso

y = max. opening  
 y = max. Maulöffnung  
 y = Apertura max. de la boca  
 y = Ouverture max. du mors  
 y = Apertura mass. del morso

gms = Pressure  
 gms = Schließkraft  
 gms = Presión  
 gms = Force de fermeture  
 gms = Sforza della chiusura

For titanium clips, please add a "T" to the reference number.

Bei Bestellung von Titan Clips, bitte der Artikelnummer ein „T“ hinzufügen.

Para clips de titanio, por favor añadir und "T" a la referencia.

Pour des clips en titane, veuillez ajouter un «T» à la référence.

Per clips in titanio, per favore aggiuntete al numero d'articolo un "T".

**Yasargil-Standard**

for permanent closure, in high quality implant steel, antimagnetic  
 für permanenten Verschluss, aus hochwertigem Implantatstahl, antimagnetisch  
 para oclusión permanente, acero de alta calidad, antimagnetico  
 pour fermeture permanente, acier de haute qualité, anti-magnétique  
 per chiusura permanente, acciaio di alta qualita, antimagnetico

<b>13-776-00</b>	<b>13-777-00</b>	<b>13-778-00</b>	<b>13-779-00</b>	<b>13-780-00</b>	<b>13-781-00</b>	<b>13-782-00</b>
x = 12.0 mm	x = 17.0 mm	x = 20.0 mm	x = 5.0 mm	x = 7.0 mm	x = 9.0 mm	x = 11.0 mm
y = 10.2 mm	y = 11.9 mm	y = 13.0 mm	y = 6.2 mm	y = 6.5 mm	y = 7.8 mm	y = 8.4 mm
gms = 200	gms = 180	gms = 180	gms = 200	gms = 200	gms = 200	gms = 200
<b>13-783-00</b>	<b>13-784-00</b>	<b>13-785-00</b>	<b>13-786-00</b>	<b>13-787-00</b>	<b>13-788-00</b>	
x = 5.0 mm	x = 7.0 mm	x = 10.0 mm	x = 8.0 mm	x = 10.0 mm	x = 5.0 mm	
y = 5.6 mm	y = 5.6 mm	y = 5.6 mm	y = 5.4 mm	y = 5.6 mm	y = 7.2 mm	
gms = 200	gms = 200	gms = 200	gms = 200	gms = 200	gms = 200	
<b>13-789-00</b>	<b>13-790-00</b>	<b>13-791-00</b>	<b>13-792-00</b>	<b>13-793-00</b>		
x = 9.0 mm	x = 11.0 mm	x = 7.0 mm	x = 11.0 mm	x = 9.0 mm		
y = 7.2 mm	y = 8.2 mm	y = 5.7 mm	y = 8.0 mm	y = 7.0 mm		
gms = 200	gms = 200	gms = 200	gms = 200	gms = 200		

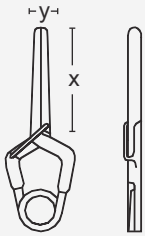

x = Jaw length  
x = Maullänge  
x = Longitud de la boca  
x = Longueur du mors  
x = Lunghezza del morso

y = max. opening  
y = max. Maulöffnung  
y = Apertura max. de la boca  
y = Ouverture max. du mors  
y = Apertura mass. del morso

gms = Pressure  
gms = Schließkraft  
gms = Presión  
gms = Force de fermeture  
gms = Sforza della chiusura

For titanium clips, please add a "T" to the reference number.

Bei Bestellung von Titan Clips, bitte der Artikelnummer ein „T“ hinzufügen.

Para clips de titanio, por favor añadir und "T" a la referencia.

Pour des clips en titane, veuillez ajouter un «T» à la référence.

Per clips in titanio, per favore aggiungete al numero d'articolo un "T".

### Yasargil-Standard

for permanent closure, with window 3,5 mm, in high quality implant steel, antimagnetic  
für permanenten Verschluss, mit Fenster 3,5 mm, aus hochwertigem Implantatstahl, antimagnetisch  
para oclusión permanente, con ventana de 3,5 mm, acero de alta calidad, antimagnetico  
pour fermeture permanente, avec fenestra 3,5 mm, acier de haute qualité, anti-magnétique  
per chiusura permanente, con finestra di 3,5 mm, acciaio di alta qualita, antimagnetico

<b>13-794-00</b>	<b>13-795-00</b>	<b>13-796-00</b>	<b>13-797-00</b>	<b>13-798-00</b>	<b>13-799-00</b>
x = 7.0 mm	x = 9.0 mm	x = 12.0 mm	x = 5.0 mm	x = 7.0 mm	x = 11.0 mm
y = 7.4 mm	y = 8.4 mm	y = 9.6 mm	y = 5.8 mm	y = 6.5 mm	y = 7.2 mm
gms = 150	gms = 150	gms = 180	gms = 150	gms = 150	gms = 180
<b>13-800-00</b>	<b>13-801-00</b>	<b>13-802-00</b>			
x = 5.0 mm	x = 7.0 mm	x = 11.0 mm			
y = 4.9 mm	y = 4.9 mm	y = 4.9 mm			
gms = 150	gms = 150	gms = 180			

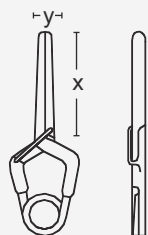

x = Jaw length	y = max. opening	gms= Pressure
x = Maullänge	y = max. Maulöffnung	gms= Schließkraft
x = Longitud de la boca	y = Apertura max. de la boca	gms= Presión
x = Longueur du mors	y = Ouverture max. du mors	gms= Force de fermeture
x = Lunghezza del morso	y = Apertura mass. del morso	gms= Sforza della chiusura

For titanium clips, please add a "T" to the reference number.

Bei Bestellung von Titan Clips, bitte der Artikelnummer ein „T“ hinzufügen.

Para clips de titanio, por favor añadir und "T" a la referencia.

Pour des clips en titane, veuillez ajouter un «T» à la référence.

Per clips in titanio, per favore aggiuntete al numero d'articolo un "T".

### Yasargil-Standard

for permanent closure, with window 3,5 mm, in high quality implant steel, antimagnetic  
 für permanenten Verschluss, mit Fenster 3,5 mm, aus hochwertigem Implantatstahl, antimagnetisch  
 para oclusión permanente, con finestra de 3,5 mm, acero de alta calidad, antimagnetico  
 pour fermeture permanente, avec fenestra 3,5 mm, acier de haute qualité, anti-magnétique  
 per chiusura permanente, con finestra di 3,5 mm, acciaio di alta qualità, antimagnetico

<b>13-803-00</b>	<b>13-804-00</b>	<b>13-805-00</b>	<b>13-806-00</b>	<b>13-807-00</b>	<b>13-808-00</b>
x = 7.0 mm	x = 9.0 mm	x = 12.0 mm	x = 5.0 mm	x = 7.0 mm	x = 11.0 mm
y = 7.9 mm	y = 9.1 mm	y = 10.3 mm	y = 6.5 mm	y = 7.2 mm	y = 7.8 mm
gms = 150	gms = 150	gms = 180	gms = 150	gms = 150	gms = 180
<b>13-809-00</b>	<b>13-810-00</b>	<b>13-811-00</b>	<b>13-812-00</b>	<b>13-813-00</b>	<b>13-814-00</b>
x = 5.0 mm	x = 7.0 mm	x = 11.0 mm	x = 5.0 mm	x = 7.0 mm	x = 11.0 mm
y = 5.5 mm	y = 5.5 mm	y = 5.5 mm	y = 7.9 mm	y = 8.8 mm	y = 10.0 mm
gms = 150	gms = 150	gms = 180	gms = 150	gms = 150	gms = 180



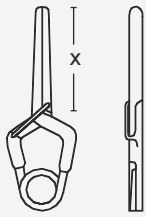

x = Jaw length  
x = Maullänge  
x = Longitud de la boca  
x = Longueur du mors  
x = Lunghezza del morso

y = max. opening  
y = max. Maulöffnung  
y = Apertura max. de la boca  
y = Ouverture max. du mors  
y = Apertura mass. del morso

gms = Pressure  
gms = Schließkraft  
gms = Presión  
gms = Force de fermeture  
gms = Sforza della chiusura

For titanium clips, please add a "T" to the reference number.

Bei Bestellung von Titan Clips, bitte der Artikelnummer ein „T“ hinzufügen.

Para clips de titanio, por favor añadir und "T" a la referencia.

Pour des clips en titane, veuillez ajouter un «T» à la référence.

Per clips in titanio, per favore aggiungete al numero d'articolo un "T".

### Yasargil-Standard

for permanent closure, with window 5.0 mm, in high quality implant steel, antimagnetic  
für permanenten Verschluss, mit Fenster 5.0 mm, aus hochwertigem Implantatstahl, antimagnetisch  
para oclusión permanente, con finestra de 5.0 mm, acero de alta calidad, antimagnetico  
pour fermeture permanente, avec fenestra 5.0 mm, acier de haute qualité, anti-magnétique  
per chiusura permanente, con finestra di 5.0 mm, acciaio di alta qualità, antimagnetico

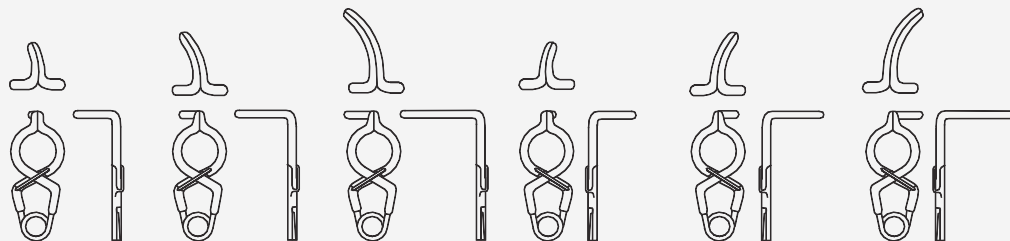

13-815-00

x = 5.0 mm  
y = 5.8 mm  
gms = 150

13-816-00

x = 7.0 mm  
y = 5.8 mm  
gms = 150

13-817-00

x = 10.0 mm  
y = 5.8 mm  
gms = 150

13-818-00

x = 5.0 mm  
y = 5.8 mm  
gms = 150

13-819-00

x = 7.0 mm  
y = 5.8 mm  
gms = 150

13-820-00

x = 10.0 mm  
y = 5.8 mm  
gms = 150

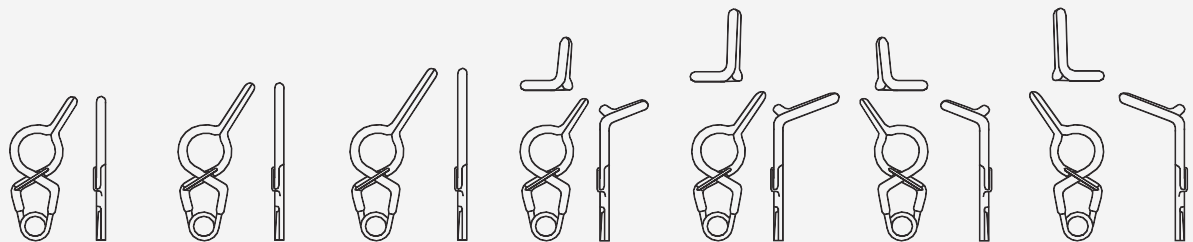

13-821-00

x = 5.0 mm  
y = 7.0 mm  
gms = 150

13-822-00

x = 7.0 mm  
y = 7.8 mm  
gms = 150

13-823-00

x = 10.0 mm  
y = 8.8 mm  
gms = 150

13-824-00

x = 5.0 mm  
y = 5.8 mm  
gms = 150

13-825-00

x = 7.0 mm  
y = 6.2 mm  
gms = 150

13-826-00

x = 5.0 mm  
y = 5.8 mm  
gms = 150

13-827-00

x = 7.0 mm  
y = 6.2 mm  
gms = 150

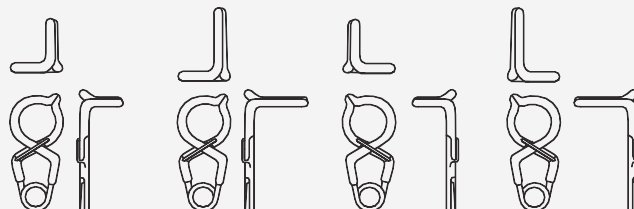

13-828-00

x = 5.0 mm  
y = 5.6 mm  
gms = 150

13-829-00

x = 7.0 mm  
y = 5.6 mm  
gms = 150

13-830-00

x = 5.0 mm  
y = 5.6 mm  
gms = 150

13-831-00

x = 7.0 mm  
y = 5.6 mm  
gms = 150

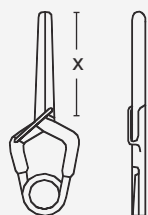

x = Jaw length	y = max. opening	gms = Pressure
x = Maullänge	y = max. Maulöffnung	gms = Schließkraft
x = Longitud de la boca	y = Apertura max. de la boca	gms = Presión
x = Longueur du mors	y = Ouverture max. du mors	gms = Force de fermeture
x = Lunghezza del morso	y = Apertura mass. del morso	gms = Sforza della chiusura

For titanium clips, please add a "T" to the reference number.

Bei Bestellung von Titan Clips, bitte der Artikelnummer ein „T“ hinzufügen.

Para clips de titanio, por favor añadir und "T" a la referencia.

Pour des clips en titane, veuillez ajouter un «T» à la référence.

Per clips in titanio, per favore aggiuntete al numero d'articolo un "T".

### Yasargil-Standard

for permanent closure, in high quality implant steel, antimagnetic  
 für permanenten Verschluss, aus hochwertigem Implantatstahl, antimagnetisch  
 para oclusión permanente, acero de alta calidad, antimagnetico  
 pour fermeture permanente, acier de haute qualité, anti-magnétique  
 per chiusura permanente, acciaio di alta qualità, antimagnetico

<b>13-832-00</b>	<b>13-833-00</b>	<b>13-834-00</b>	<b>13-835-00</b>	<b>13-836-00</b>	<b>13-837-00</b>	<b>13-838-00</b>
x = 9.0 mm	x = 9.0 mm	x = 9.0 mm	x = 15.0 mm	x = 15.0 mm	x = 15.0 mm	x = 9.0 mm
y = 7.0 mm	y = 6.8 mm	y = 6.1 mm	y = 9.2 mm	y = 8.7 mm	y = 7.4 mm	y = 6.2 mm
gms = 90	gms = 90	gms = 110	gms = 90	gms = 110	gms = 110	gms = 110

<b>13-839-00</b>	<b>13-840-00</b>	<b>13-841-00</b>	<b>13-842-00</b>
x = 20.0 mm	x = 20.0 mm	x = 17.0 mm	x = 13.0 mm
y = 11.4 mm	y = 11.0 mm	y = 9.9 mm	y = 7.5 mm
gms = 110	gms = 90	gms = 90	gms = 90

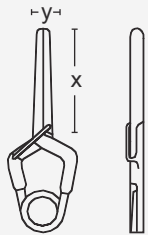

x = Jaw length  
x = Maullänge  
x = Longitud de la boca  
x = Longueur du mors  
x = Lunghezza del morso

y = max. opening  
y = max. Maulöffnung  
y = Apertura max. de la boca  
y = Ouverture max. du mors  
y = Apertura mass. del morso

gms = Pressure  
gms = Schließkraft  
gms = Presión  
gms = Force de fermeture  
gms = Sforza della chiusura

For titanium clips, please add a "T" to the reference number.

Bei Bestellung von Titan Clips, bitte der Artikelnummer ein „T“ hinzufügen.

Para clips de titanio, por favor añadir un "T" a la referencia.

Pour des clips en titane, veuillez ajouter un «T» à la référence.

Per clips in titanio, per favore aggiungete al numero d'articolo un "T".

### Yasargil-Mini

for permanent closure, in high quality implant steel, antimagnetic  
für permanenten Verschluss, aus hochwertigem Implantatstahl, antimagnetisch  
para oclusión permanente, acero de alta calidad, antimagnetico  
pour fermeture permanente, acier de haute qualité, anti-magnétique  
per chiusura permanente, acciaio di alta qualita, antimagnetico



13-843-00  
x = 3.0 mm  
y = 3.3 mm  
gms = 110

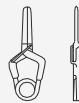

13-844-00  
x = 5.0 mm  
y = 4.0 mm  
gms = 110



13-845-00  
x = 3.0 mm  
y = 3.3 mm  
gms = 110

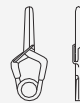

13-846-00  
x = 5.0 mm  
y = 4.0 mm  
gms = 110

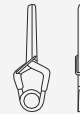

13-847-00  
x = 7.0 mm  
y = 4.6 mm  
gms = 110



13-848-00  
x = 3.0 mm  
y = 3.2 mm  
gms = 110



13-849-00  
x = 4.0 mm  
y = 3.8 mm  
gms = 110

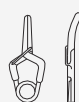

13-850-00  
x = 4.0 mm  
y = 3.6 mm  
gms = 110

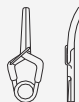

13-851-00  
x = 5.0 mm  
y = 3.8 mm  
gms = 110



13-852-00  
x = 4.0 mm  
y = 3.6 mm  
gms = 110



13-853-00  
x = 5.0 mm  
y = 4.0 mm  
gms = 110

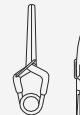

13-854-00  
x = 7.0 mm  
y = 4.4 mm  
gms = 110



13-855-00  
x = 4.0 mm  
y = 3.6 mm  
gms = 110



13-856-00  
x = 4.0 mm  
y = 3.5 mm  
gms = 110

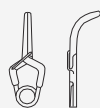

13-857-00  
x = 5.0 mm  
y = 4.0 mm  
gms = 110

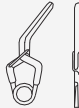

13-858-00  
x = 5.0 mm  
y = 3.5 mm  
gms = 130

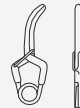

13-859-00  
x = 6.0 mm  
y = 6.0 mm  
gms = 130

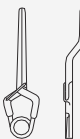

13-860-00  
x = 4.0 mm  
y = 7.0 mm  
gms = 130

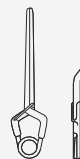

13-861-00  
x = 7.0 mm  
y = 5.7 mm  
gms = 130 gms

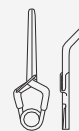

13-862-00  
x = 7.0 mm  
y = 4.5 mm  
gms = 130

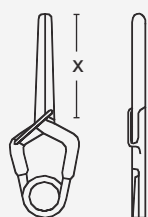

x = Jaw length  
 x = Maullänge  
 x = Longitud de la boca  
 x = Longueur du mors  
 x = Lunghezza del morso

y = max. opening  
 y = max. Maulöffnung  
 y = Apertura max. de la boca  
 y = Ouverture max. du mors  
 y = Apertura mass. del morso

gms= Pressure  
 gms= Schließkraft  
 gms= Presión  
 gms= Force de fermeture  
 gms= Sforza della chiusura

For titanium clips, please add a "T" to the reference number.

Bei Bestellung von Titan Clips, bitte der Artikelnummer ein „T“ hinzufügen.

Para clips de titanio, por favor añadir und "T" a la referencia.

Pour des clips en titane, veuillez ajouter un «T» à la référence.

Per clips in titanio, per favore aggiuntete al numero d'articolo un "T".

### Yasargil-Mini

for temporary closure, in high quality implant steel, antimagnetic  
 für temporären Verschluss, aus hochwertigem Implantatstahl, antimagnetisch  
 para oclusión temporal, acero de alta calidad, antimagnetico  
 pour fermeture temporaire, acier de haute qualité, anti-magnétique  
 per chiusura temporanea, acciaio di alta qualita, antimagnetico



13-863-00

x = 3.0 mm  
 y = 3.3 mm  
 gms = 90

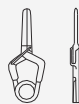

13-864-00

x = 5.0 mm  
 y = 4.0 mm  
 gms = 70



13-865-00

x = 4.0 mm  
 y = 3.8 mm  
 gms = 70

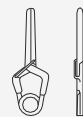

13-866-00

x = 7.0 mm  
 y = 4.6 mm  
 gms = 70

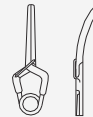

13-867-01

x = 7.0 mm  
 y = 4.4 mm  
 gms = 70



13-868-00

x = 5.0 mm  
 y = 4.0 mm  
 gms = 70



Scoville

13-869-23

23 cm - 9"  
x = 8 mm



Holsher

13-870-24

24 cm - 9½"  
x = 7 mm



Scoville

13-871-20

20 cm - 8"  
x = 7 mm

Martin

13-872-21

21 cm - 8¼"  
x = 7 mm



**Toennis**

13-873-01

15 cm - 6"

13-874-02

19 cm - 7 1/2"



**Halle**

13-875-20

20 cm - 8"



**Smithwick**

13-876-17 17 cm - 6 3/4"

13-876-21 21 cm - 8 1/4"



**Hoen**

13-877-22

22 cm - 8 3/4"

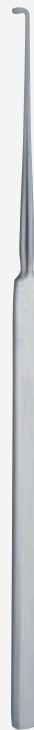

**Cushing**

13-878-19

13-878-28



13-879-19

13-879-28

19 cm - 7 1/2"

28 cm - 11"

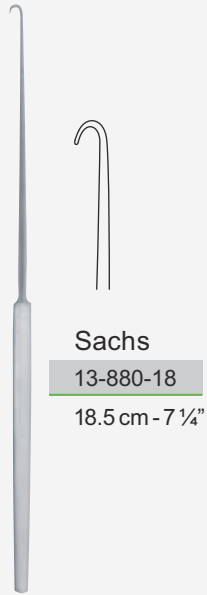

**Sachs**  
13-880-18  
18.5 cm - 7 1/4"



**Graham**  
13-881-18  
18.5 cm - 7 1/4"

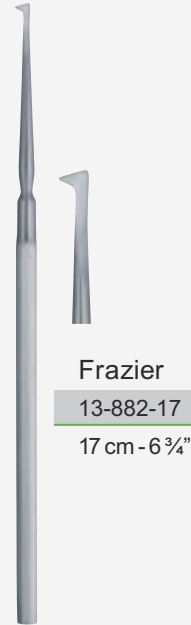

**Frazier**  
13-882-17  
17 cm - 6 3/4"

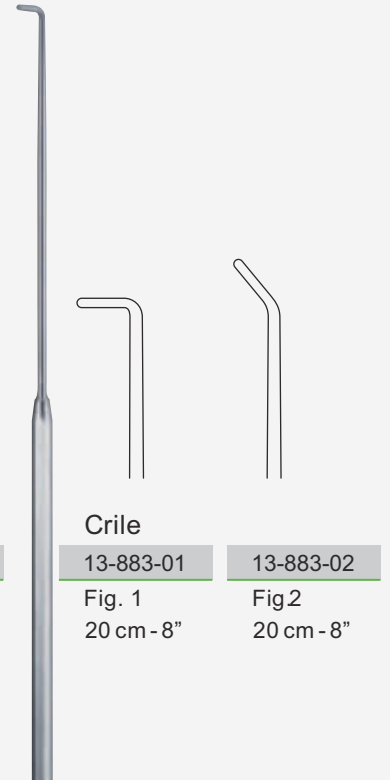

**Crile**  
13-883-01  
Fig. 1  
20 cm - 8"  
13-883-02  
Fig. 2  
20 cm - 8"



**Toennis**  
13-885-15  
15 cm - 6"



**Dandy**  
13-886-20  
Fig. 1  
20 cm - 8"



13-887-20  
Fig. 2  
20 cm - 8"



13-888-20  
Fig. 3  
20 cm - 8"



**Adson**  
13-889-20  
Fig. 1  
13-890-20  
Fig. 2  
20 cm - 8"

Nerve hooks – Dura hooks  
 Nervenhooken – Durahaken  
 Ganchos para nervios – Ganchos para duramadre  
 Crochets à nerfs – Crochets pour duremère  
 Ganci Nerve - ganci Dura



Love

13-891-19

Fig. 1



13-892-19

Fig. 2



13-893-19

Fig. 3

19 cm - 7 1/2"



Yasargil

13-894-31 31 cm - 12 1/4"

13-894-41 41 cm - 16 1/4"

Galea retractor  
 Galeahaken  
 Retractor de Galea  
 Retracteur Galea  
 Rettrotore di Galea

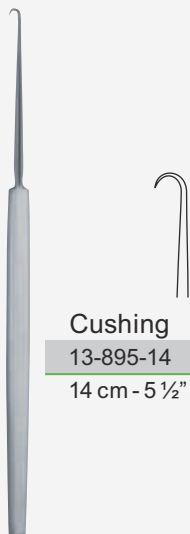

Cushing

13-895-14

14 cm - 5 1/2"



Frazier

13-896-13

13-896-18

sharp  
 spitz  
 agudo  
 pointu  
 acuto



Frazier

13-897-13

13-897-18

blunt  
 stumpf  
 romos  
 mousse  
 smusso

13 cm - 5"

18 cm - 7"



Lahey

13-898-01

13 cm - 5"





Zöllner

90°

13-899-01

Roundknife, angledup  
Rundschnittmesser, nach oben gebogen  
Cuchillo redondo, angulado arriba  
Coureau rond, coudé en haut  
Coltello rotondo, angolato in alto



90°

13-900-00

Roundknife, angleddown  
Rundschnittmesser, nach unten gebogen  
Cuchillo redondo, angulado a bajo  
Coureau rond, coudé en bas  
Coltello rotondo, angolato in basso



13-901-00

Sickleknife, angledup  
Sichelmesser, nach oben gebogen  
Cuchillo de hoz, angulado arriba  
Coureau faucille, courbe vers le haut  
Coltello a forma di falce, angolato in alto



13-902-00

Sickleknife, angleddown  
Sichelmesser, nach unten gebogen  
Cuchillo de hoz, angulado a bajo  
Coureau faucille, courbe vers le bas  
Coltello a forma di falce, curvato in basso



13-903-00

Lancetknife, curved to left  
Lanzenmesser, links gebogen  
Cuchillo lanceolado, angulado a la izquierda  
Coureau lancéolaire, courbe à gauche  
Coltelloancelato, curvato a sinistra



13-904-00

Lancetknife, curved to right  
Lanzenmesser, rechts gebogen  
Cuchillo lanceolado, angulado a la derecha  
Coureau lancéolaire, courbe à droite  
Coltelloancelato, curvato a destra



13-905-01

Raspatory, curved to left  
Raspatorium, links gebogen  
Raspatorio, angulado a la izquierda  
Décolleur, courbe à gauche  
Raspatorio, curvato a sinistra



13-906-01

Raspatory, curved to right  
Raspatorium, rechts gebogen  
Raspatorio, angulado a la derecha  
Décolleur, courbe à droite  
Raspatorio, curvato a destra



13-907-01

Wireguide  
Führungsgabel  
Tenedor guía  
Fourchette d'introduction  
Forchetta guida



**Sachs**  
 13-908-21



13-909-21



13-910-21 21 cm - 8 1/4"



**Horsley**  
 13-911-20  
 20 cm - 8"



**Smithwick**  
 13-912-29  
 29 cm - 11 1/2"

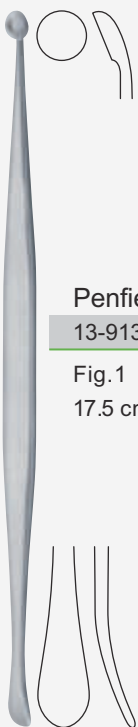

**Penfield**  
 13-913-17  
 Fig. 1  
 17.5 cm - 7"

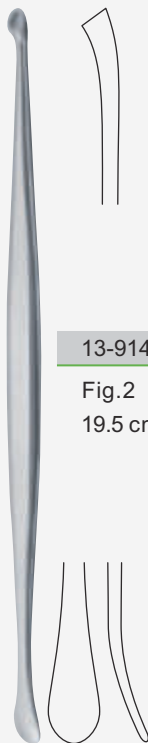

13-914-19  
 Fig. 2  
 19.5 cm - 7 3/4"

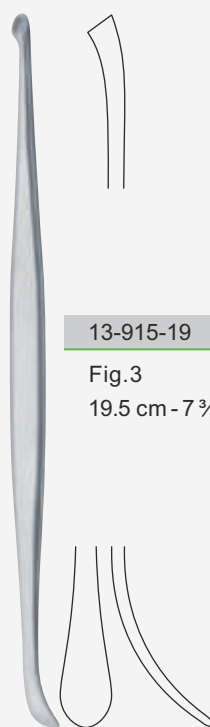

13-915-19  
 Fig. 3  
 19.5 cm - 7 3/4"

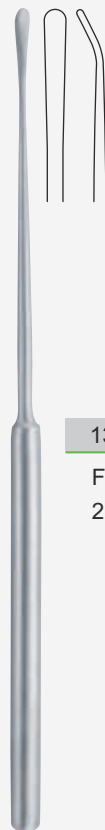

13-916-21  
 Fig. 4  
 21.5 cm - 8 1/2"

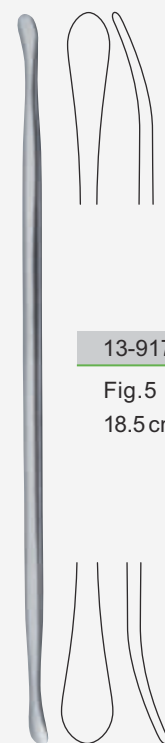

13-917-18  
 Fig. 5  
 18.5 cm - 7 1/4"



Yasargil

13-918-19

straight  
gerade  
recta  
droit  
rette



13-919-19



13-920-19



13-921-19



13-922-19

19 cm - 7 1/2"

13-923-19

bayonet  
bajonett  
bayoneta  
baionette  
baionetta

13-924-19

13-925-19

13-926-19

13-927-19

19 cm - 7 1/2"



Yasargil

13-928-19

straight  
gerade  
recta  
droit  
rette

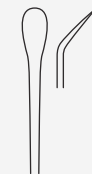

13-929-19



13-930-19



13-931-19

19 cm - 7 1/2"

01-932-22

bayonet  
bajonett  
bayoneta  
baionette  
baionetta

01-933-22

01-934-22

01-935-22

19 cm - 7 1/2"



01-936-22



01-937-22

19 cm - 7 1/2"

straight, with Twist-fixationhook  
gerade, mit Dreh-Fixierhaken  
recta, con gancho de fijación  
droit, avec crochet de fixation  
rette, con uncino di fissaggio "Twist"

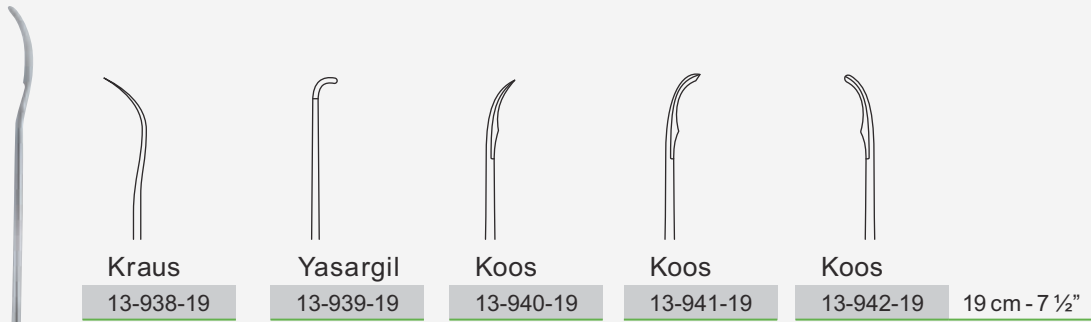

**Kraus**

13-938-19

**Yasargil**

13-939-19

**Koos**

13-940-19

**Koos**

13-941-19

**Koos**

13-942-19

19 cm - 7 1/2"

bayonet  
 bajonett  
 bayoneta  
 baionette  
 baionetta



**Jacobson**

13-943-19

19 cm - 7 1/2"



**Krayen bühl**

13-944-19

13-945-19

13-946-19

13-947-19

19 cm - 7 1/2"

without knob  
 ohne Knopf  
 sin bola  
 sans boule  
 senza bottone

with knob  
 mit Knopf  
 con bola  
 avec boule  
 con bottone

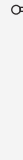
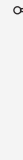
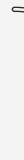
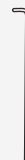

**Jacobson**

13-948-19

**Jacobson**

13-949-19

**Fisch**

13-950-19

19 cm - 7 1/2"





Hardy

13-951-25

25 cm - 9 3/4"

13-952-25

25 cm - 9 3/4"

13-953-25

25 cm - 9 3/4"

13-954-25

25 cm - 9 3/4"

bayonet, sharp inner edge  
bajonett, innen scharf  
bayoneta, cortante al interno  
baionette, tranchant à l'interno  
baionetta, acuto all'interno



Hardy

13-955-27

4 mmØ

13-956-27

6 mmØ

27 cm - 10 3/4"

bayonet, malleable  
bajonett, biegsam  
bayoneta, maleable  
baionette, malléable  
baionetta, flessibile



**Vannas**

13-957-08    13-958-08    8 cm - 3 1/4"

Vannas-Schneide  
 Vannas-blade  
 Lame de Vannas  
 Hoja de Vannas  
 Lama Vannas

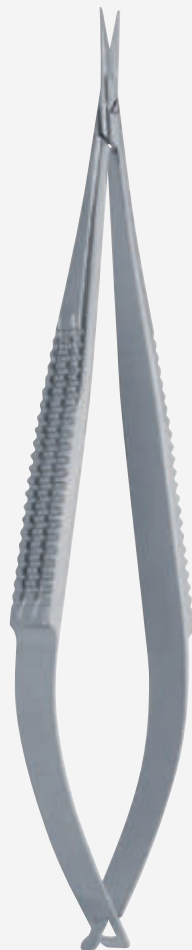
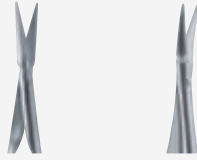

**Welsh**

13-959-12    13-960-12    12 cm - 4 3/4"

straight	curved	Blade 10mm, sharp
gerade	gebogen	Schneide 10mm, spitz
recta	curva	Hoja 10mm, agudas
droite	courbe	Lame 10mm, pointu
retta	curva	Lama 10mm, acuta

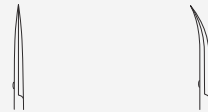

13-961-12    13-962-12    13-963-12    12 cm - 4 3/4"

straight	curved	angled up	Vannas-blade
gerade	gebogen	aufgewinkelt	Vannas-Schneide
recta	curva	acodada	Hoja de Vannas
droite	courbe	angulaire	Lama de Vannas
retta	curva	angolata	Vannas-lama

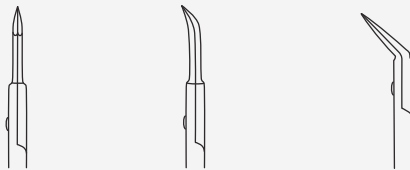

13-964-12    12 cm - 4 3/4"

straight	Vein-blade (Biemer)
gerade	Venen-Schneide (Biemer)
recta	Hoja para venas (Biemer)
droite	Lame pour vènes (Biemer)
retta	Lama per vene (Biemer)





**Welsh**

13-965-15

13-965-18

straight, short blades  
gerade, kurze Schneide  
recta, hojas cortas  
droites, lames courtes  
retta, lama corta



13-966-15

13-966-18

curved, short blades  
gebogen, kurze Schneide  
curva, hojas cortas  
courbes, lames courtes  
curva, lama corta



13-967-15

13-967-18

straight, long blades  
gerade, lange Schneide  
recta, hojas largas  
droites, lames longues  
retta, lama lunga



13-968-15

15 cm - 6"

13-968-18

18 cm - 7"

curved, long blades  
gebogen, lange Schneide  
curva, hojas largas  
courbes, lames longues  
curva, lama lunga



13-969-15

13-969-18

straight, saw edge  
gerade, gezahnt  
recta, dentadas  
droites, dentelés  
retta, dentata



13-970-15

13-970-18

curved, saw edge  
gebogen, gezahnt  
curva, dentadas  
courbes, dentelés  
curva, dentata



13-971-15 15 cm - 6"

13-971-18 18 cm - 7"

angled on flat, 45°  
kniegebogen, 45°  
acodada, 45°  
angulaires, 45°  
angolata, 45°



**Yasargil**

13-972-18

straight  
gerade  
recta  
droits  
retta



13-973-18

curved  
gebogen  
curva  
courbes  
curva



13-974-18

18.5 cm - 7 1/4"

angled on flat  
kniegebogen  
acodada  
angulaires  
angolata



Welsh

13-975-12

straight  
 gerade  
 recta  
 droites  
 retta



13-976-12 12cm - 4 3/4"

curved  
 gebogen  
 curva  
 courbes  
 curva

Long blades 14 mm, smooth, sharp  
 Lange Schneide 14 mm, glatt, spitz  
 Hojas largas 14 mm, lisas, agudas  
 Lama lunga 14 mm, liscia, acuta  
 Lames longues 14 mm, lisses, pointues



13-977-12

straight, saw edge  
 gerade, gezahnt  
 recta, dentadas  
 droites, dentelés  
 retta, dentata



13-978-12 12cm - 4 3/4"

curved, saw edge  
 gebogen, gezahnt  
 curva, dentadas  
 courbes, dentelés  
 curva, dentata

Long blades 14 mm, sharp  
 Lange Schneide 14 mm, spitz  
 Hojas largas 14 mm, agudas  
 Lames longues 14 mm, pointues  
 Lama lunga 14 mm, acuta



13-979-14

straight  
 gerade  
 recta  
 droites  
 retta



13-980-14 14.5 cm - 5 3/4"

curved  
 gebogen  
 curva  
 courbes  
 curva

Vannas-blades, smooth, sharp  
 Vannas-Schneide, glatt, spitz  
 Hojas de Vannas, lisas, agudas  
 Lames de Vannas, lisses, pointues  
 Vannas-lama, liscia, acuta



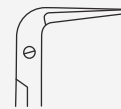
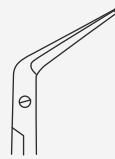

**Yasargil**

13-981-17

13-982-17

13-983-17

13-984-17

13-985-17

17 cm - 6 3/4"

25°

45°

60°

90°

125°

with ball  
mit Knopf  
con botón  
avec bouton  
con bottone

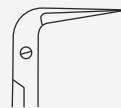
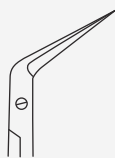

**Yasargil**

13-986-17

13-987-17

13-988-17

13-989-17

13-990-17

17 cm - 6 3/4"

25°

45°

60°

90°

125°

without ball  
mit ohne Knopf  
sin bola botón  
sans boule bouton  
con senza bottone



**Irwan**

13-991-14

13-991-18

straight, sharp  
 gerade, spitz  
 rectas, agudas  
 droites, pointues  
 retta, acuta



13-992-14

13-992-18

curved, sharp  
 gebogen, spitz  
 curvas, agudas  
 courbes, pointues  
 curva, acuta



13-993-14

13-993-18

straight, blunt  
 gerade, stumpf  
 rectas, romas  
 droites, mousses  
 retta, smussa



13-994-14

13-994-18

curved, blunt  
 gebogen, stumpf  
 curvas, romas  
 courbes, mousses  
 curva, smussa

14.5 cm 5 3/4"

short blades 8 mm, smooth  
 kurze Schneide 8 mm, glatt  
 hojas cortas 8mm, lisos  
 lames courtes 8 mm, lisses  
 lama corta 8 mm, liscia



13-995-14

13-995-18

straight, sharp  
 gerade, spitz  
 rectas, agudas  
 droites, pointues  
 retta, acuta



13-996-14

13-996-18

curved, sharp  
 gebogen, spitz  
 curvas, agudas  
 courbes, pointues  
 curva, acuta



13-997-14

13-997-18

straight, blunt  
 gerade, stumpf  
 rectas, romas  
 droites, mousses  
 retta, smussa



13-998-14

13-998-18

curved, blunt  
 gebogen, stumpf  
 curvas, romas  
 courbes, mousses  
 curva, smussa

14.5 cm 5 3/4"

long blades 14 mm, smooth  
 lange Schneide 14 mm, glatt  
 hojas largas 14mm, lisos  
 lames longues 14 mm, lisses  
 lama lunga 14 mm, liscia



**Vannas**

13-999-12

12 cm - 5"

7 mm Ø

13-100-12

12 cm - 5"

7 mm Ø

**Vannas**

13-101-15

15 cm - 6"

8 mm Ø

13-102-15

15 cm - 6"

8 mm Ø



**Castroviejo**

13-103-15

8 mm Ø

13-104-15

8 mm Ø

15 cm - 6"



**Irwan**

13-105-08

18 cm - 7"

sharp/sharp

13-106-08

18 cm - 7"

sharp/sharp

13-107-08

18 cm - 7"

sharp/blunt

13-108-08

18 cm - 7"

sharp/blunt

13-109-08

18 cm - 7"

blunt/blunt

13-110-08

18 cm - 7"

blunt/blunt

8 mm Ø

13-105-10

18 cm - 7"

10 mm Ø

13-106-10

18 cm - 7"

10 mm Ø

13-107-18

18 cm - 7"

10 mm Ø

13-108-18

18 cm - 7"

10 mm Ø

13-109-18

18 cm - 7"

10 mm Ø

13-110-18

18 cm - 7"

10 mm Ø

10 mm Ø

Micro scissors with round handle  
 Mikroscheren mit Rundgriff  
 Micro tijeras con mango redondo  
 Micro ciseaux avec manche ronde  
 Micro forbici con manico rotondo

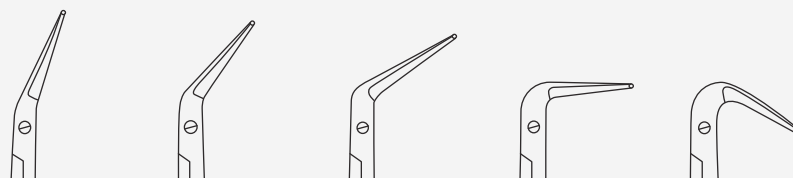

**Irwan Pro**

13-111-17	13-112-17	13-113-17	13-114-17	13-115-17	17 cm - 6 3/4"
25°	45°	60°	90°	125°	8 mmØ

Blade 10 mm, with ball, sharp  
 Schneide 10 mm, mit Knopf, spitz  
 Hojas 10 mm, con botón, agudas  
 Lames 10 mm, avec bouton, pointues  
 Lama 10 mm, con bottone, acuta

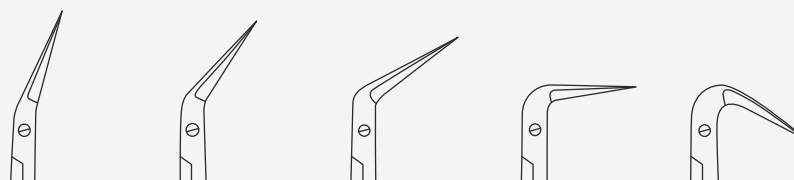

13-116-18	13-117-18	13-118-18	13-119-18	13-120-18	18 cm - 7"
25°	45°	60°	90°	125°	8 mmØ

Blade 10 mm, without ball, sharp  
 Schneide 10 mm, ohne Knopf, spitz  
 Hojas 10 mm, sin botón, agudas  
 Lames 10 mm, sans bouton, pointues  
 Lama 10 mm, senza bottone, acuta

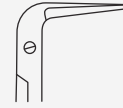
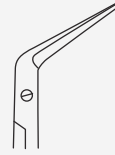

**Irwan Pro**

13-121-18

13-122-18

13-123-18

13-124-18

13-125-18

18 cm 7"

25°

45°

60°

90°

125°

8 mmØ

with ball  
mit Knopf  
con botón  
avec bouton  
con bottone

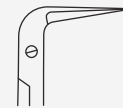
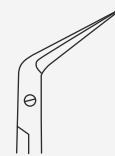

13-126-18

13-127-18

13-128-18

13-129-18

13-130-18

18 cm 7"

25°

45°

60°

90°

125°

8 mmØ

without ball  
ohne Knopf  
sin botón  
sans bouton  
senza bottone



**Dylex**

13-131-15

13-132-15

15 cm - 6"

9 mmØ

9 mmØ



**Jacobson**

13-133-16

13-134-16

13-135-16

16 cm - 6 1/4"

13-133-18

13-134-18

13-135-18

18 cm - 7"

straight  
 gerade  
 recta  
 droits  
 retta

curved  
 gebogen  
 curva  
 courbes  
 curva

angled, 45°  
 abgewinkelt, 45°  
 acodada, 45°  
 angulaires, 45°  
 angolata, 45°



13-136-16

13-137-16

13-138-16

16 cm - 6 1/4"

13-136-18

13-137-18

13-138-18

18 cm - 7"

Vannas blade  
 Vannas Schneide  
 Hoja de Vannas  
 Lame de Vannas  
 Lama Vannas



**Yasargil-mod.**

13-139-18

13-140-18

18 cm - 7"

13-139-22

13-140-22

22.5 cm - 8 3/4"



13-141-22

13-142-22

22.5 cm - 8 3/4"

Vannas blade  
 Vannas Schneide  
 Hoja de Vannas  
 Lame de Vannas  
 Lama Vannas





**Yasargil**

13-143-20

13-144-20

13-145-20

13-146-20

20 cm - 8"

13-143-22

13-144-22

13-145-22

13-146-22

22. cm - 8 3/4"

straight  
gerade  
recta  
droits  
retta

curved  
gebogen  
curva  
courbes  
curva

straight, saw edge  
gerade, gezahnt  
recta, dentadas  
droits, dentelées  
retta, dentata

curved, saw edge  
gebogen, gezahnt  
curva, dentadas  
courbes, dentelées  
curva, dentata

Blade smooth, sharp  
Schneide glatt, spitz  
Hojas lisas, agudas  
Lames lisses, pointues  
Lama liscia, acuta



13-147-20

13-148-20

20 cm - 8"

13-147-22

13-148-22

22. cm - 8 3/4"

Vannas blade  
Vannas Schneide  
Hoja de Vannas  
Lame de Vannas  
Lama Vannas



13-149-20

13-150-20

20 cm - 8"

13-149-22

13-150-22

22. cm - 8 3/4"

Dissector blade, blunt  
Präparier-Schneide, stumpf  
Hojas de disección, roma  
Lames de dissction, moussé  
Lama da dissezione, smussa



Pierse

13-156-12 12 cm - 4 3/4"

13-156-13 13.5 cm - 5 1/4"

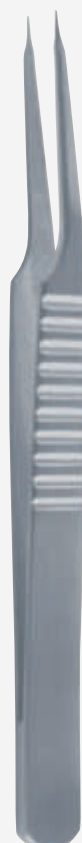

Sholm

13-157-11

x = 0.2 mm  
 very fine  
 sehr fein  
 muy fino  
 très fin  
 molto fino



13-158-11

11 cm - 4 1/4"

x = 0.3 mm





**Lazar**  
13-159-15  
15.5 cm - 6"  
0.5 mm



13-160-15  
15.5 cm - 6"  
0.8 mm



9 mm Ø

**Lester**

13-161-18



9 mm Ø

13-162-18



9 mm Ø

13-163-18

1x2



9 mm Ø

13-164-18

1x2

18 cm - 7"

Tying platform 6.0 mm x 0.4mm, smooth

Fadenplatte 6,0 mm x 0,4 mm, glatt

Plataforma 6.0 mm x 0.4mm, lisa

Plate-forme 6.0 mm x 0.4mm, lisse

Piano per sutura 6.0 mm x 0.4mm, liscio

9 mm Ø

13-165-18

9 mm Ø

13-166-18

9 mm Ø

13-167-18

1x2

9 mm Ø

13-168-18

1x2

18 cm - 7"

Tying platform 6.0 mm x 0.4mm, diamond coated

Fadenplatte 6,0 mm x 0,4 mm, diamantiert

Plataforma 6.0 mm x 0.4mm, diamantada

Plate-forme 6.0 mm x 0.4mm, diamanté

Piano per sutura 6.0 mm x 0.4mm, diamantata



9 mm Ø

13-169-18



9 mm Ø

13-170-18



9 mm Ø

13-171-18

1x2



9 mm Ø

13-172-18

1x2

18 cm - 7"

Tying platform 6.0 mm x 0.8mm, smooth

Fadenplatte 6,0 mm x 0,8 mm, glatt

Plataforma 6.0 mm x 0.8mm, lisa

Plate-forme 6.0 mm x 0.8mm, lisse

Piano per sutura 6.0 mm x 0.8mm, liscio

9 mm Ø

13-173-18

9 mm Ø

13-174-18

9 mm Ø

13-175-18

1x2

9 mm Ø

13-176-18

1x2

18 cm - 7"

Tying platform 6.0 mm x 0.8mm, diamond coated

Fadenplatte 6,0 mm x 0,8 mm, diamantiert

Plataforma 6.0 mm x 0.8mm, diamantada

Plate-forme 6.0 mm x 0.8mm, diamanté

Piano per sutura 6.0 mm x 0.8mm, diamantata



**Lester**

13-177-15	13-178-15	13-179-15	13-180-15	15 cm - 6"
13-177-18	13-178-18	13-179-18	13-180-18	18 cm - 7"
13-177-21	13-178-21	13-179-21	13-180-21	21 cm - 8 1/4"
13-177-23	13-178-23	13-179-23	13-180-23	23 cm - 9"
0.3 mm	0.3 mm	0.7 mm	0.7 mm	8 mmØ

Jaw smooth  
Maul glatt  
Boca lisa  
Mors lisse  
Morso liscio



13-181-15	13-182-15	13-183-15	13-184-15	15 cm - 6"
13-181-18	13-182-18	13-183-18	13-184-18	18 cm - 7"
13-181-21	13-182-21	13-183-21	13-184-21	21 cm - 8 1/4"
13-181-23	13-182-23	13-183-23	13-184-23	23 cm - 9"
0.3 mm	0.3 mm	0.7 mm	0.7 mm	8 mmØ

Tying platform 6.0 mm x 0.3mm, smooth  
Fadenplatte 6,0 mm x 0,3mm, glatt  
Plataforma 6.0 mm x 0.3mm, lisa  
Plate-forme 6.0 mm x 0.3mm, lisse  
Piano per sutura 6.0 mm x 0.3mm, liscio



13-185-15	13-186-15	13-187-15	13-188-15	15 cm - 6"
13-185-18	13-186-18	13-187-18	13-188-18	18 cm - 7"
13-185-21	13-186-21	13-187-21	13-188-21	21 cm - 8 1/4"
13-185-23	13-186-23	13-187-23	13-188-23	23 cm - 9"
0.3 mm	0.3 mm	0.7 mm 1x2	0.7 mm 1x2	8 mmØ

Tying platform 6.0 mm x 0.7mm, smooth  
Fadenplatte 6,0 mm x 0,7 mm, glatt  
Plataforma 6.0 mm x 0.7mm, lisa  
Plate-forme 6.0 mm x 0.7mm, lisse  
Piano per sutura 6.0 mm x 0.7 mm, liscio

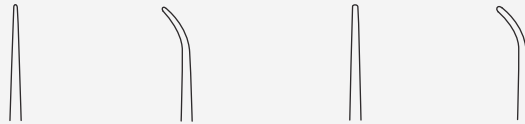

**Lester**

13-189-15	13-190-15	13-191-15	13-192-15	15 cm - 6"
13-189-18	13-190-18	13-191-18	13-192-18	18 cm - 7"
13-189-21	13-190-21	13-191-21	13-192-21	21 cm - 8 1/4"
13-189-23	13-190-23	13-191-23	13-192-23	23 cm - 9"

0.3 mm      0.3 mm      0.7 mm      0.7 mm      8 mmØ

diamond coated  
diamantiert  
diamantada  
diamanté  
diamantata

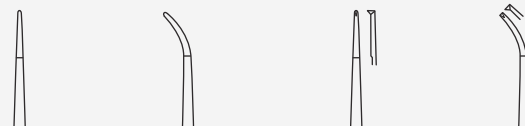

13-193-15	13-194-15	13-195-15	13-196-15	15 cm - 6"
13-193-18	13-194-18	13-195-18	13-196-18	18 cm - 7"
13-193-21	13-194-21	13-195-21	13-196-21	21 cm - 8 1/4"
13-193-23	13-194-23	13-195-23	13-196-23	23 cm - 9"

0.3 mm      0.3 mm      0.7 mm      0.7 mm      8 mmØ

1x2      1x2

Tying platform 6.0 mm x 0.3mm, diamond coated  
Fadenplatte 6,0 mm x 0,3mm, diamantiert  
Plataforma 6.0mm x 0.3mm, diamantada  
Plate-forme 6.0 mm x 0.3mm, diamanté  
Piano per sutura 6.0 mm x 0.3mm, diamantata

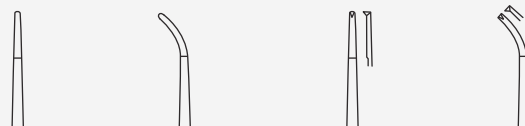

13-197-15	13-198-15	13-199-15	13-200-15	15 cm - 6"
13-197-18	13-198-18	13-199-18	13-200-18	18 cm - 7"
13-197-21	13-198-21	13-199-21	13-200-21	21 cm - 8 1/4"
13-197-23	13-198-23	13-199-23	13-200-23	23 cm - 9"

0.3 mm      0.3 mm      0.7 mm      0.7 mm      8 mmØ

1x2      1x2

Tying platform 6.0 mm x 0.7mm, diamond coated  
Fadenplatte 6,0 mm x 0,7mm, diamantiert  
Plataforma 6.0mm x 0.7mm, diamantada  
Plate-forme 6.0 mm x 0.7mm, diamanté  
Piano per sutura 6.0 mm x 0.7mm, diamantata



**Jacobson**

13-201-16

13-201-18

straight, sharp  
gerade, spitz  
recta, aguda  
droit, pointue  
retta, acuta

13-205-16

13-205-18

straight, sharp  
gerade, spitz  
recta, aguda  
droit, pointue  
retta, acuta

diamond coated  
diamantiert  
diamantada  
diamanté  
diamantata



13-202-16

13-202-18

straight, blunt  
gerade, stumpf  
recta, roma  
droit, mousse  
retta, smussa

13-206-16

13-206-18

straight, blunt  
gerade, stumpf  
recta, roma  
droit, mousse  
retta, smussa



13-203-16

13-203-18

angled, sharp  
abgewinkelt, spitz  
acodada, aguda  
angulaire, pointue  
angolata, acuta

13-207-16

13-207-18

angled, sharp  
abgewinkelt, spitz  
acodada, aguda  
angulaire, pointue  
angolata, acuta



13-204-16 16 cm - 6 1/4"

13-204-18 18 cm - 7"

angled, blunt  
abgewinkelt, stumpf  
acodada, roma  
angulaire, mousse  
angolata, smussa

13-208-16 16 cm - 6 1/4"

13-208-18 18 cm - 7"

angled, blunt  
abgewinkelt, stumpf  
acodada, roma  
angulaire, mousse  
angolata, smussa



**Yasargil**

13-209-22

13-209-22

22.5 cm - 8 3/4"

spoon form  
löffelförmig  
forma de cuchara  
forme de cuillère  
forma di cucchiaio



13-210-22

13-210-22

22.5 cm - 8 3/4"

plan toothed  
flach gezahnt  
dentada  
dentelé  
dentato



13-211-22 3.0 mm

13-211-22 5.0 mm

22.5 cm - 8 3/4"

curette form  
kürettenförmig  
forma de cureta  
forme de curette  
forma di curetta



**Yasagil**

13-212-20

13-212-22

straight, sharp  
gerade, spitz  
recta, aguda  
droit, pointue  
retta, acuta

diamond coated  
diamantiert  
diamantado  
diamanté  
diamantato



13-213-20

13-213-22

straight, blunt  
gerade, stumpf  
recta, roma  
droit, mousse  
retta, smussa

13-214-20

13-214-22

angled, sharp  
abgewinkelt, spitz  
acodada, aguda  
angulaire, pointue  
angolata, acuta

13-215-20

13-215-22

angled, blunt  
abgewinkelt, stumpf  
acodada, roma  
angulaire, mousse  
angolata, smussa

20 cm - 8"

22.5 cm - 8 3/4"

13-216-22

straight, sharp  
gerade, spitz  
recta, aguda  
droit, pointue  
retta, acuta

Titanium

13-217-22

straight, blunt  
gerade, stumpf  
recta, roma  
droit, mousse  
retta, smussa

22.5 cm - 8 3/4"

13-218-20

13-218-22

angled, sharp  
abgewinkelt, spitz  
acodada, aguda  
angulaire, pointue  
angolata, acuta

13-219-20

13-219-22

angled, blunt  
abgewinkelt, stumpf  
acodada, roma  
angulaire, mousse  
angolata, smussa

20 cm - 8"

22.5 cm - 8 3/4"



**Wolf**

9 mmØ

13-220-21

13-220-23

straight, sharp  
 gerade, spitz  
 recta, aguda  
 droit, pointue  
 retta, acuta



9 mmØ

13-221-21

13-221-23

straight, blunt  
 gerade, stumpf  
 recta, roma  
 droit, mousse  
 retta, smussa



9 mmØ

13-222-21

13-222-23

angled, sharp  
 abgewinkelt, spitz  
 acodada, aguda  
 angulaire, pointue  
 angolata, acuta



9 mmØ

13-223-21

13-223-23

angled, blunt  
 abgewinkelt, stumpf  
 acodada, roma  
 angulaire, mousse  
 angolata, smussa

21 cm - 8 1/4"

23 cm - 9"

9 mmØ

13-224-21

13-224-23

straight, sharp  
 gerade, spitz  
 recta, aguda  
 droit, pointue  
 retta, acuta

9 mmØ

13-225-21

13-225-23

straight, blunt  
 gerade, stumpf  
 recta, roma  
 droit, mousse  
 retta, smussa

9 mmØ

13-226-21

13-226-23

angled, sharp  
 abgewinkelt, spitz  
 acodada, aguda  
 angulaire, pointue  
 angolata, acuta

9 mmØ

13-227-21

13-227-23

angled, blunt  
 abgewinkelt, stumpf  
 acodada, roma  
 angulaire, mousse  
 angolata, smussa

21 cm - 8 1/4"

23 cm - 9"

diamond coated  
 diamantiert  
 diamantado  
 diamanté  
 diamantato



**Herman**

13-228-15

13-228-18

13-228-21

13-228-23

1.0 x 0.5 mm  
smooth  
glatt  
lisa  
lisse  
liscia

13-229-15

13-229-18

13-229-21

13-229-23

1.0 x 0.5 mm  
slightly serrated  
fein gerieft  
lig. estriada  
légèrement strié  
fina zigrinata

13-230-15

13-230-18

13-230-21

13-230-23

2.0 x 1.0 mm  
smooth  
glatt  
lisa  
lisse  
liscia

13-231-15

13-231-18

13-231-21

13-231-23

2.0 x 1.0 mm  
slightly serrated  
fein gerieft  
lig. estriada  
légèrement strié  
fina zigrinata

13-232-15

13-232-18

13-232-21

13-232-23

1.0 x 0.5 mm  
diamond coated  
diamantiert  
diamantada  
diamanté  
diamantata

13-233-15

13-233-18

13-233-21

13-233-23

2.0 x 1.0 mm 9 mmØ  
diamond coated  
diamantiert  
diamantada  
diamanté  
diamantata

15 cm - 6"

18 cm - 7"

21 cm - 8 1/4"

23 cm - 9"

13-234-15

13-234-18

13-234-21

13-234-23

1.0 x 0.5 mm  
smooth  
glatt  
lisa  
lisse  
liscia

13-235-15

13-235-18

13-235-21

13-235-23

1.0 x 0.5 mm  
slightly serrated  
fein gerieft  
lig. estriada  
légèrement strié  
fina zigrinata

13-236-15

13-236-18

13-236-21

13-236-23

2.0 x 1.0 mm  
smooth  
glatt  
lisa  
lisse  
liscia

13-237-15

13-237-18

13-237-21

13-237-23

2.0 x 1.0 mm  
slightly serrated  
fein gerieft  
lig. estriada  
légèrement strié  
fina zigrinata

13-238-15

13-238-18

13-238-21

13-238-23

1.0 x 0.5 mm  
diamond coated  
diamantiert  
diamantada  
diamanté  
diamantata

13-239-15

13-239-18

13-239-21

13-239-23

2.0 x 1.0 mm 9 mmØ  
diamond coated  
diamantiert  
diamantada  
diamanté  
diamantata

15 cm - 6"

18 cm - 7"

21 cm - 8 1/4"

23 cm - 9"

Titanium



**Herman**

13-240-21

13-240-23

1.0 mm x 0.5 mm

smooth  
 glatt  
 liso  
 lisse  
 liscia



13-241-21

13-241-23

1.0 mm x 0.5 mm

serrated  
 gerieft  
 estriada  
 strié  
 zigrinata

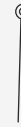

13-242-21

13-242-23

2.0 mm x 1.0 mm

smooth  
 glatt  
 liso  
 lisse  
 liscia

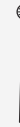

13-243-21

13-243-23

2.0 mm x 1.0 mm

serrated  
 gerieft  
 estriada  
 strié  
 zigrinata

21 cm - 8 1/4"

23 cm - 9"

9 mmØ



13-244-21

13-244-23

1.0 mm x 0.5 mm

diamond coated  
 diamantiert  
 diamantada  
 diamanté  
 diamantata



13-245-21

13-245-23

2.0 mm x 1.0 mm

diamond coated  
 diamantiert  
 diamantada  
 diamanté  
 diamantata

21 cm - 8 1/4"

23 cm - 9"

9 mmØ





**Stenberg**

13-246-15	13-247-15	13-248-15	13-249-15	15 cm - 6"
13-246-18	13-247-18	13-248-18	13-249-18	18 cm - 7"
13-246-21	13-247-21	13-248-21	13-249-21	21 cm - 8 ¼"
13-246-23	13-247-23	13-248-23	13-249-23	23 cm - 9"
x = 1.2 mm straight gerade recta droit retta	x = 2.0 mm straight gerade recta droit retta	x = 1.2 mm angled abgewinkelt acodada angulaire angolata	x = 2.0 mm angled abgewinkelt acodada angulaire angolata	



Castroviejo

13-250-14

13-251-14

13-252-14

13-253-14

14 cm - 5 1/2"

x = 11.0 mm x 0.75 mm

straight  
gerade  
recta  
droit  
retto

curved  
gebogen  
curva  
courbe  
curvo

straight, diamond coated  
gerade, diamantiert  
recta, diamantada  
droit, diamanté  
retto, diamantato

curved, diamond coated  
gebogen, diamantiert  
curva, diamantada  
courbe, diamanté  
curvo, diamantato

without ratchet, fine jaws  
 ohne Sperre, feines Maul  
 sin cremallera, boca fina  
 sans crémaillère, mors fine  
 senza cremagliera, morso fino

13-254-14

13-255-14

13-256-14

13-257-14

14 cm - 5 1/2"

x = 11.0 mm x 0.75 mm

straight  
gerade  
recta  
droit  
retto

curved  
gebogen  
curva  
courbe  
curvo

straight, diamond coated  
gerade, diamantiert  
recta, diamantada  
droit, diamanté  
retto, diamantato

curved, diamond coated  
gebogen, diamantiert  
curva, diamantada  
courbe, diamanté  
curvo, diamantato

with ratchet, fine jaws  
 mit Sperre, feines Maul  
 con cremallera, boca fina  
 avec crémaillère, mors fine  
 con cremagliera, morso fino



**Jacobson**

<b>13-258-18</b>	<b>13-259-18</b>	<b>13-260-18</b>	<b>13-261-18</b>	<b>18 cm - 7"</b>
x = 1 mm	x = 1 mm	x = 1 mm	x = 1 mm	
straight	curved	straight, diamond coated	curved, diamond coated	
gerade	gebogen	gerade, diamantiert	gebogen, diamantiert	
recta	curva	recta, diamantada	curva, diamantada	
droit	courbe	droit, diamanté	courbe, diamanté	
retto	curvo	retto, diamantato	curvo, diamantato	

without ratchet  
ohne Sperre  
sin cremallera  
sans crémaillère  
senza cremagliera

<b>13-262-18</b>	<b>13-263-18</b>	<b>13-264-18</b>	<b>13-265-18</b>	<b>18 cm - 7"</b>
x = 1 mm	x = 1 mm	x = 1 mm	x = 1 mm	
straight	curved	straight, diamond coated	curved, diamond coated	
gerade	gebogen	gerade, diamantiert	gebogen, diamantiert	
recta	curva	recta, diamantada	curva, diamantada	
droit	courbe	droit, diamanté	courbe, diamanté	
retto	curvo	retto, diamantato	curvo, diamantato	

with ratchet  
mit Sperre  
con cremallera  
avec crémaillère  
con cremagliera



<b>13-266-18</b>	<b>13-267-18</b>	<b>13-268-18</b>	<b>13-269-18</b>	<b>18 cm - 7"</b>
x = 1 mm	x = 1 mm	x = 1 mm	x = 1 mm	1 mm
straight, smooth	curved, smooth	straight, serrated	curved, serrated	
gerade, glatt	gebogen, glatt	gerade, gerieft	gebogen, gerieft	
recta, liso	curva, lisa	recta, estriada	curva, estriada	
droit, lisse	courbe, lisse	droit, strié	courbe, strié	
retto, liscio	curvo, liscio	retto, zigrinato	curvo, zigrinato	

without ratchet  
ohne Sperre  
sin cremallera  
sans crémaillère  
senza cremagliera

<b>13-270-18</b>	<b>13-271-18</b>	<b>13-272-18</b>	<b>13-273-18</b>	<b>18 cm - 7"</b>
x = 1 mm	x = 1 mm	x = 1 mm	x = 1 mm	1 mm
straight, smooth	curved, smooth	straight, serrated	curved, serrated	
gerade, glatt	gebogen, glatt	gerade, gerieft	gebogen, gerieft	
recta, liso	curva, lisa	recta, estriada	curva, estriada	
droit, lisse	courbe, lisse	droit, strié	courbe, strié	
retto, liscio	curvo, liscio	retto, zigrinato	curvo, zigrinato	

with ratchet  
mit Sperre  
con cremallera  
avec crémaillère  
con cremagliera





Yasargil

13-274-18	13-275-18	13-276-18	13-277-18	18 cm - 7"
13-274-20	13-275-20	13-276-20	13-277-20	20 cm - 8"
straight	curved	straight, diamond coated	curved, diamond coated	
gerade	gebogen	gerade, diamantiert	gebogen, diamantiert	
recta	curva	recta, diamantada	curva, diamantada	
droit	courbe	droit, diamanté	courbe, diamanté	
retto	curvo	retto, diamantato	curvo, diamantato	

without ratchet  
 ohne Sperre  
 sin cremallera  
 sans crémaillère  
 senza cremagliera

13-278-18	13-279-18	13-280-18	13-281-18	18 cm - 7"
13-278-20	13-279-20	13-280-20	13-281-20	20 cm - 8"
straight	curved	straight, diamond coated	curved, diamond coated	
gerade	gebogen	gerade, diamantiert	gebogen, diamantiert	
recta	curva	recta, diamantada	curva, diamantada	
droit	courbe	droit, diamanté	courbe, diamanté	
retto	curvo	retto, diamantato	curvo, diamantato	

with ratchet  
 mit Sperre  
 con cremallera  
 avec crémaillère  
 con cremagliera



Jacobson

13-282-21

x = 1 mm  
straight  
gerade  
recta  
droit  
retto

13-283-21

x = 1 mm  
curved  
gebogen  
curva  
courbe  
curvo

13-284-21

x = 1 mm  
straight, diamond coated  
gerade, diamantiert  
recta, diamantada  
droit, diamanté  
retto, diamantato

13-285-21

x = 1 mm  
curved, diamond coated  
gebogen, diamantiert  
curva, diamantada  
courbe, diamanté  
curvo, diamantato

21 cm - 8 1/4"

without ratchet  
ohne Sperre  
sin cremallera  
sans crémaillère  
senza cremagliera

13-286-21

x = 1 mm  
straight  
gerade  
recta  
droit  
retto

13-287-21

x = 1 mm  
curved  
gebogen  
curva  
courbe  
curvo

13-288-21

x = 1 mm  
straight, diamond coated  
gerade, diamantiert  
recta, diamantada  
droit, diamanté  
retto, diamantato

13-289-21

x = 1 mm  
curved, diamond coated  
gebogen, diamantiert  
curva, diamantada  
courbe, diamanté  
curvo, diamantato

21 cm - 8 1/4"

with ratchet  
mit Sperre  
con cremallera  
avec crémaillère  
con cremagliera



13-290-21

x = 1 mm  
straight, smooth  
gerade, glatt  
recta, liso  
droit, lisse  
retto, liscio

13-291-21

x = 1 mm  
curved, smooth  
gebogen, glatt  
curva, lisa  
courbe, lisse  
curvo, liscio

13-292-21

x = 1 mm  
straight, serrated  
gerade, gerieft  
recta, estriada  
droit, strié  
retto, zigrinato

13-293-21

x = 1 mm  
curved, serrated  
gebogen, gerieft  
curva, estriada  
courbe, strié  
curvo, zigrinato

21 cm - 8 1/4"

without ratchet  
ohne Sperre  
sin cremallera  
sans crémaillère  
senza cremagliera

13-295-21

x = 1 mm  
straight, smooth  
gerade, glatt  
recta, liso  
droit, lisse  
retto, liscio

13-296-21

x = 1 mm  
curved, smooth  
gebogen, glatt  
curva, lisa  
courbe, lisse  
curvo, liscio

13-297-21

x = 1 mm  
straight, serrated  
gerade, gerieft  
recta, estriada  
droit, strié  
retto, zigrinato

13-298-21

x = 1 mm  
curved, serrated  
gebogen, gerieft  
curva, estriada  
courbe, strié  
curvo, zigrinato

21 cm - 8 1/4"

with ratchet  
mit Sperre  
con cremallera  
avec crémaillère  
con cremagliera



Micro needle holders with round handle  
 Mikronadelhalter mit Rundgriff  
 Micro porta agujas con mango redondo  
 Micro porte aiguilles avec manche ronde  
 Porta Micro aghi con manico rotondo



**Hubson**

13-299-01	13-300-01	11 cm - 4 1/4"	8 mmØ
13-299-02	13-300-02	12.5 cm - 5"	7 mmØ
13-299-03	13-300-03	13 cm - 5"	8 mmØ
13-299-04	13-300-04	13 cm - 5"	10 mmØ
13-299-05	13-300-05	15 cm - 6"	8 mmØ
13-299-06	13-300-06	18 cm - 7"	8 mmØ
13-299-07	13-300-07	18 cm - 7"	10 mmØ

straight  
 gerade  
 recta  
 droit  
 retto

curved  
 gebogen  
 curva  
 courbe  
 curvo

without ratchet  
 ohne Sperre  
 sin cremallera  
 sans crémaillère  
 senza cremagliera

13-301-01	13-302-01	11 cm - 4 1/4"	8 mmØ
13-301-02	13-302-02	12.5 cm - 5"	7 mmØ
13-301-03	13-302-03	13 cm - 5"	8 mmØ
13-301-04	13-302-04	13 cm - 5"	10 mmØ
13-301-05	13-302-05	15 cm - 6"	8 mmØ
13-301-06	13-302-06	18 cm - 7"	8 mmØ
13-301-07	13-302-07	18 cm - 7"	10 mmØ

straight  
 gerade  
 recta  
 droit  
 retto

curved  
 gebogen  
 curva  
 courbe  
 curvo

with ratchet  
 mit Sperre  
 con cremallera  
 avec crémaillère  
 con cremagliera



**Barraquer**

13-303-14

straight  
gerade  
recta  
droit  
retto

13-304-14

curved  
gebogen  
curva  
courbe  
curvo

13-305-14

straight, diamond coated  
gerade, diamantiert  
recta, diamantada  
droit, diamanté  
retto, diamantato

13-306-14

curved, diamond coated  
gebogen, diamantiert  
curva, diamantada  
courbe, diamanté  
curvo, diamantato

14 cm - 5 1/2"

8 mmØ

without ratchet, extra delicate jaws  
ohne Sperre, sehr feines Maul  
sin cremallera, boca muy fina  
sans crémaillère, mors très fine  
senza cremagliera, morso molto fino

13-307-14

straight  
gerade  
recta  
droit  
retto

13-308-14

curved  
gebogen  
curva  
courbe  
curvo

13-309-14

straight, diamond coated  
gerade, diamantiert  
recta, diamantada  
droit, diamanté  
retto, diamantato

13-310-14

curved, diamond coated  
gebogen, diamantiert  
curva, diamantada  
courbe, diamanté  
curvo, diamantato

14 cm - 5 1/2"

8 mmØ

with ratchet, extra delicate jaws  
mit Sperre, sehr feines Maul  
con cremallera, boca muy fina  
avec crémaillère, mors très fine  
con cremagliera, morso molto fino



**Dylex Hegar**

13-311-15

15 cm - 6"  
9 mm Ø

without ratchet, curved  
ohne Sperre, gebogen  
sin cremallera, curvo  
sans crémaillère, courbe  
senza cremagliera, curvo





**Luke**

13-312-18	13-313-18
18.5 cm - 7 1/4"	18.5 cm - 7 1/4"
0.8 mm x 0.8 mm	0.8 mm x 0.8 mm

Titanium, with ratchet  
 Titan, mit Sperre  
 Titano, con cremallera  
 Titane, avec crémaillère  
 Titanio, con cremagliera



**Luke Modified**

13-314-18	13-315-18
18 cm - 7"	18 cm - 7"
0.3 mm x 0.4 mm	0.3 mm x 0.4 mm

Titanium, with ratchet  
 Titan, mit Sperre  
 Titano, con cremallera  
 Titane, avec crémaillère  
 Titanio, con cremagliera





**York**

13-320-20

20 cm - 8"

0.5 mm x 0.8 mm

13-321-20

20 cm - 8"

0.5 mm x 0.8 mm

Titanium, with ratchet  
Titan, mit Sperre  
Titano, con cremallera  
Titane, avec crémaillère  
Titanio, con cremagliera



**Zeff**

13-316-20

0.4 x 0.6 mm

13-317-20

0.4 x 0.6 mm

13-318-20

0.6 x 0.6 mm

13-319-20

0.6 x 0.6 mm

20 cm - 8"

Titanium, with ratchet  
Titan, mit Sperre  
Titano, con cremallera  
Titane, avec crémaillère  
Titanio, con cremagliera



Carlson  
 13-322-01



13-323-01 22.5 cm - 8 3/4"

13-322-02

13-323-02 22.5 cm - 8 3/4"

without ratchet  
 ohne Sperre  
 sin cremallera  
 sans crémaillère  
 senza cremagliera

Titanium  
 Titan  
 Titano  
 Titane  
 Titanio

13-324-22

13-325-22 22.5 cm - 8 3/4"

with ratchet  
 mit Sperre  
 con cremallera  
 avec crémaillère  
 con cremagliera

Titanium  
 Titan  
 Titano  
 Titane  
 Titanio



**Yasargil**

13-326-20	13-327-20	13-328-20	13-329-20	20 cm - 8"
13-326-22	13-327-22	13-328-22	13-329-22	22.5 cm - 8 3/4"
13-326-24	13-327-24	13-328-24	13-329-24	24 cm - 9 1/2"
x = 0.4 mm	x = 0.4 mm	x = 0.9 mm	x = 0.9 mm	
straight gerade recta droit retto	curved gebogen curva courbe curvo	straight gerade recta droit retto	curved gebogen curva courbe curvo	

without ratchet  
ohne Sperre  
sin cremallera  
sans crémaillère  
senza cremagliera

13-330-20	13-331-20	13-332-20	13-333-20	20 cm - 8"
13-330-22	13-331-22	13-332-22	13-333-22	22.5 cm - 8 3/4"
13-330-24	13-331-24	13-332-24	13-333-24	24 cm - 9 1/2"
x = 0.4 mm	x = 0.4 mm	x = 0.9 mm	x = 0.9 mm	
straight gerade recta droit retto	curved gebogen curva courbe curvo	straight gerade recta droit retto	curved gebogen curva courbe curvo	

without ratchet, diamond coated  
ohne Sperre, diamantiert  
sin cremallera, diamantada  
sans crémaillère, diamanté  
senza cremagliera, diamantato



Jacobson

13-334-18

straight  
 gerade  
 recta  
 droit  
 retto



13-335-18

curved  
 gebogen  
 curva  
 courbe  
 curvo



13-336-18

straight, diamond coated  
 gerade, diamantiert  
 recta, diamantada  
 droit, diamanté  
 retto, diamantato



13-337-18

curved, diamond coated  
 gebogen, diamantiert  
 curva, diamantada  
 courbe, diamanté  
 curvo, diamantato

18 cm - 7"

without ratchet  
 ohne Sperre  
 sin cremallera  
 sans crémaillère  
 senza cremagliera

13-338-18

straight  
 gerade  
 recta  
 droit  
 retto

13-339-18

curved  
 gebogen  
 curva  
 courbe  
 curvo

13-340-18

straight, diamond coated  
 gerade, diamantiert  
 recta, diamantada  
 droit, diamanté  
 retto, diamantato

13-341-18

curved, diamond coated  
 gebogen, diamantiert  
 curva, diamantada  
 courbe, diamanté  
 curvo, diamantato

18 cm - 7"

with ratchet  
 mit Sperre  
 con cremallera  
 avec crémaillère  
 con cremagliera



Range

13-342-23	13-343-23	13-344-23	13-345-23	23 cm - 9"	9 mmØ
x = 1.0 mm straight gerade recta droit retto	x = 1.0 mm curved gebogen curva courbe curvo	x = 1.0 mm straight, diamond coated gerade, diamantiert recta, diamantada droit, diamanté retto, diamantato	x = 1.0 mm curved, diamond coated gebogen, diamantiert curva, diamantada courbe, diamanté curvo, diamantato		

without ratchet  
ohne Sperre  
sin cremallera  
sans crémaillère  
senza cremagliera

13-346-23	13-347-23	13-348-23	13-349-23	23 cm - 9"	9 mmØ
x = 1.0 mm straight gerade recta droit retto	x = 1.0 mm curved gebogen curva courbe curvo	x = 1.0 mm straight, diamond coated gerade, diamantiert recta, diamantada droit, diamanté retto, diamantato	x = 1.0 mm curved, diamond coated gebogen, diamantiert curva, diamantada courbe, diamanté curvo, diamantato		

with ratchet  
mit Sperre  
con cremallera  
avec crémaillère  
con cremagliera



13-350-23	13-351-23	13-352-23	13-353-23	23 cm - 9"	9 mmØ
-----------	-----------	-----------	-----------	------------	-------

straight, smooth  
gerade, glatt  
recta, liso  
droit, lisse  
retto, liscio

curved, smooth  
gebogen, glatt  
curva, lisa  
courbe, lisse  
curvo, liscio

straight, serrated  
gerade, gerieft  
recta, estriada  
droit, strié  
retto, zigrinato

curved, serrated  
gebogen, gerieft  
curva, estriada  
courbe, strié  
curvo, zigrinato

without ratchet  
ohne Sperre  
sin cremallera  
sans crémaillère  
senza cremagliera

13-354-23	13-355-23	13-356-23	13-357-23	23 cm - 9"	9 mmØ
-----------	-----------	-----------	-----------	------------	-------

straight, smooth  
gerade, glatt  
recta, liso  
droit, lisse  
retto, liscio

curved, smooth  
gebogen, glatt  
curva, lisa  
courbe, lisse  
curvo, liscio

straight, serrated  
gerade, gerieft  
recta, estriada  
droit, strié  
retto, zigrinato

curved, serrated  
gebogen, gerieft  
curva, estriada  
courbe, strié  
curvo, zigrinato

with ratchet  
mit Sperre  
con cremallera  
avec crémaillère  
con cremagliera



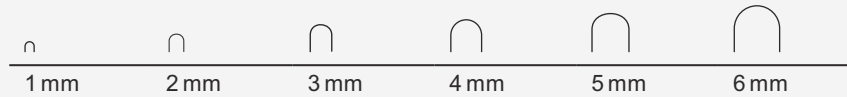
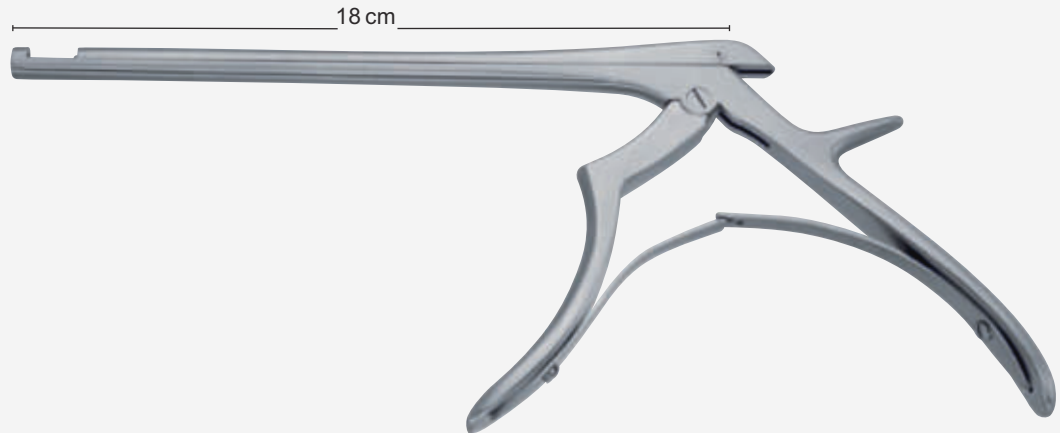

Ferris- Smith-Kerrison

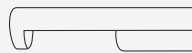

13-358-01	13-359-01	13-360-01	13-361-01	1 mm
13-358-02	13-359-02	13-360-02	13-361-02	2 mm
13-358-03	13-359-03	13-360-03	13-361-03	3 mm
13-358-04	13-359-04	13-360-04	13-361-04	4 mm
13-358-05	13-359-05	13-360-05	13-361-05	5 mm
13-358-06	13-359-06	13-360-06	13-361-06	6 mm



13-362-07	13-363-07	13-364-07	13-365-07	1 mm
13-362-08	13-363-08	13-364-08	13-365-08	2 mm
13-362-09	13-363-09	13-364-09	13-365-09	3 mm
13-362-10	13-363-10	13-364-10	13-365-10	4 mm
13-362-11	13-363-11	13-364-11	13-365-11	5 mm
13-362-12	13-363-12	13-364-12	13-365-12	6 mm



13-366-13	13-367-13	13-368-13	13-369-13	1 mm
13-366-14	13-367-14	13-368-14	13-369-14	2 mm
13-366-15	13-367-15	13-368-15	13-369-15	3 mm
13-366-16	13-367-16	13-368-16	13-369-16	4 mm
13-366-17	13-367-17	13-368-17	13-369-17	5 mm
13-366-18	13-367-18	13-368-18	13-369-19	6 mm



20 cm Thin footplate

13-369-20	13-370-19	13-371-11	13-371-01	1 mm
13-369-21	13-370-20	13-371-22	13-371-02	2 mm
13-369-22	13-370-21	13-371-33	13-371-03	3 mm
13-369-23	13-370-22	13-371-44	13-371-04	4 mm
13-369-24	13-370-23	13-371-55	13-371-05	5 mm
13-369-25	13-370-24	13-371-66	13-371-06	6 mm

x = 15 cm - 6"      x = 18 cm - 7"      x = 20 cm - 8"      x = 23 cm - 9"

**i** add "B" with catalogue part number if required in black TiN coating  
 add "E" with catalogue part number if required with ejector

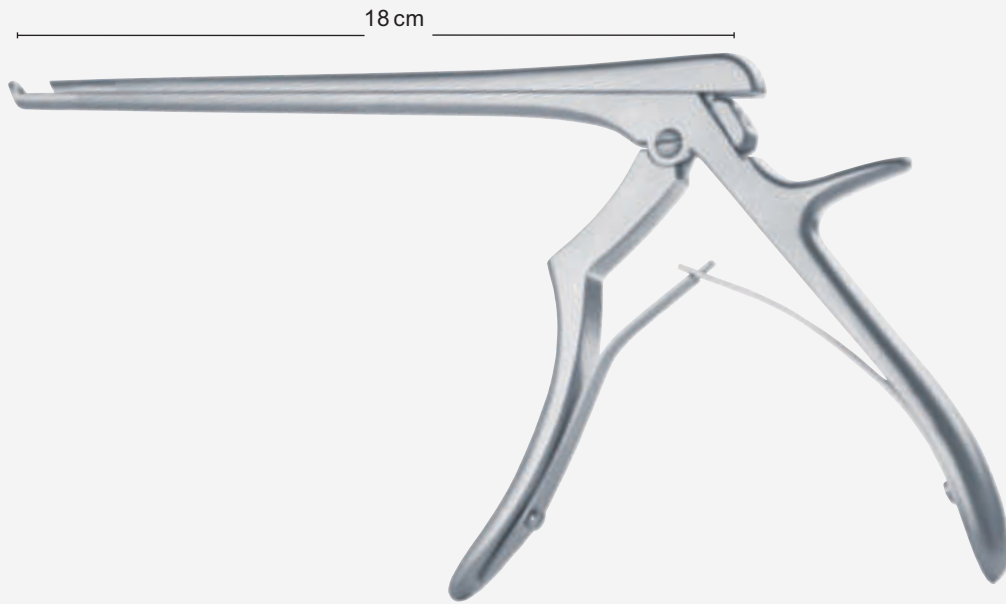

1 mm	2 mm	3 mm	4 mm	5 mm	6 mm

Ferris- Smith-Kerrison (Detachable)

	13-372-01	13-372-07	13-373-01	1 mm
	13-372-02	13-372-08	13-373-02	2 mm
	13-372-03	13-372-09	13-373-03	3 mm
	13-372-04	13-372-10	13-373-04	4 mm
	13-372-05	13-372-11	13-373-05	5 mm
	13-372-06	13-372-12	13-373-06	6 mm
	13-374-01	13-374-07	13-375-01	1 mm
	13-374-02	13-374-08	13-375-02	2 mm
	13-374-03	13-374-09	13-375-03	3 mm
	13-374-04	13-374-10	13-375-04	4 mm
	13-374-05	13-374-11	13-375-05	5 mm
	13-374-06	13-374-12	13-375-06	6 mm
	13-376-01	13-376-13	13-377-01	1 mm
	13-376-02	13-376-14	13-377-02	2 mm
	13-376-03	13-376-15	13-377-03	3 mm
	13-376-04	13-376-16	13-377-04	4 mm
	13-376-05	13-376-17	13-377-05	5 mm
	13-376-06	13-376-18	13-377-06	6 mm
	13-376-07	13-376-19	13-377-11	1 mm
	13-376-08	13-376-20	13-377-12	2 mm
Thin footplate	13-376-09	13-376-21	13-377-07	3 mm
Dünne Fußplatte	13-376-10	13-376-22	13-377-08	4 mm
Lámina de punzonar estrecha	13-376-11	13-376-23	13-377-09	5 mm
Plaque de coupe étroite	13-376-12	13-376-24	13-377-10	6 mm
Battente sottile				

x = 18 cm - 7"      x = 20 cm - 8"      x = 23 cm - 9"

**i** add "B" with catalogue part number if required in black TiN coating  
add "E" with catalogue part number if required with ejector

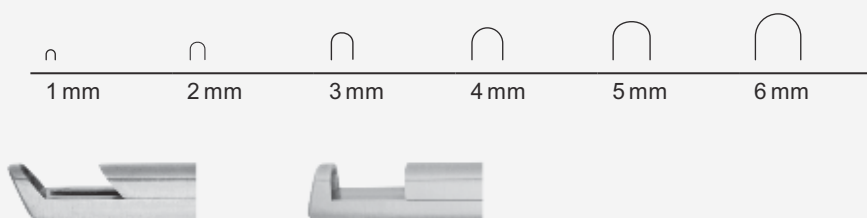
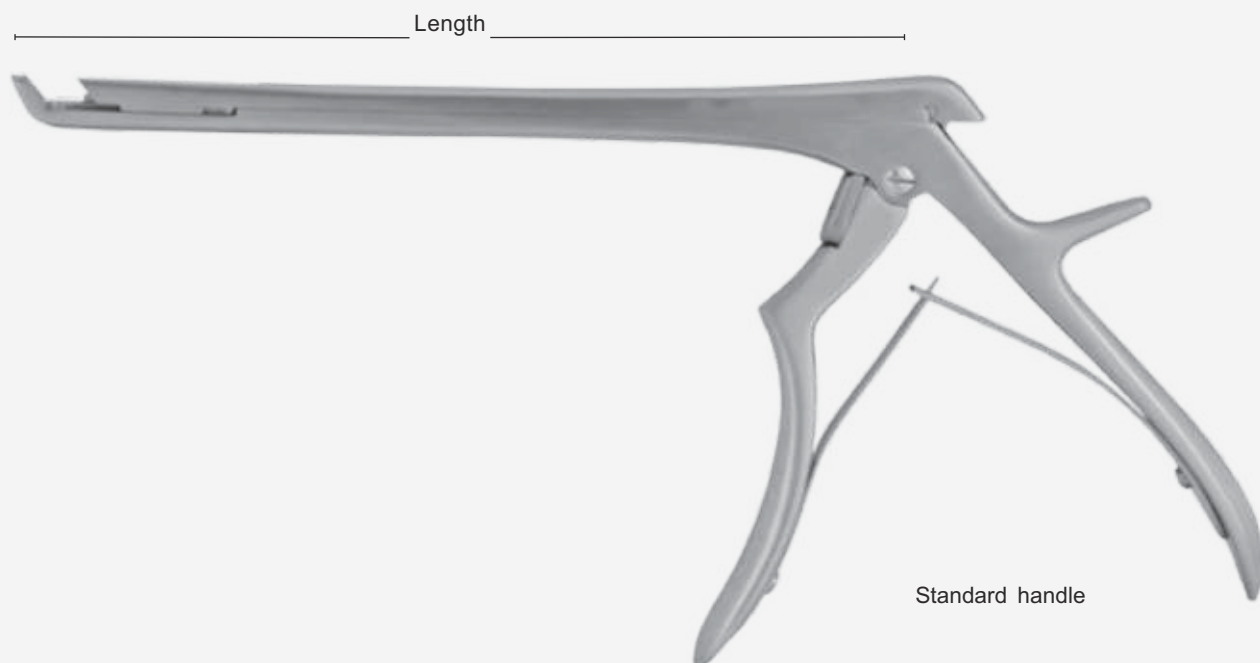

**Ferris- Smith-Kerrison**

Fig. 1	Fig. 2	Length
13-677-01	13-679-01	1 mm 18 cm / 7"
13-678-01	13-680-01	1 mm 23 cm / 9"
13-677-02	13-679-02	2 mm 18 cm / 7"
13-678-02	13-680-02	2 mm 23 cm / 9"
13-677-03	13-679-03	3 mm 18 cm / 7"
13-678-03	13-680-03	3 mm 23 cm / 9"
13-677-04	13-679-04	4 mm 18 cm / 7"
13-678-04	13-680-04	4 mm 23 cm / 9"
13-677-05	13-679-05	5 mm 18 cm / 7"
13-678-05	13-680-05	5 mm 23 cm / 9"
13-677-06	13-679-06	6 mm 18 cm / 7"
13-678-06	13-680-06	6 mm 23 cm / 9"

Upwards cutting 40°

Upwards cutting 90°

**i** add "B" with catalogue part number if required in black TIN coating  
 add "E" with catalogue part number if required with ejector



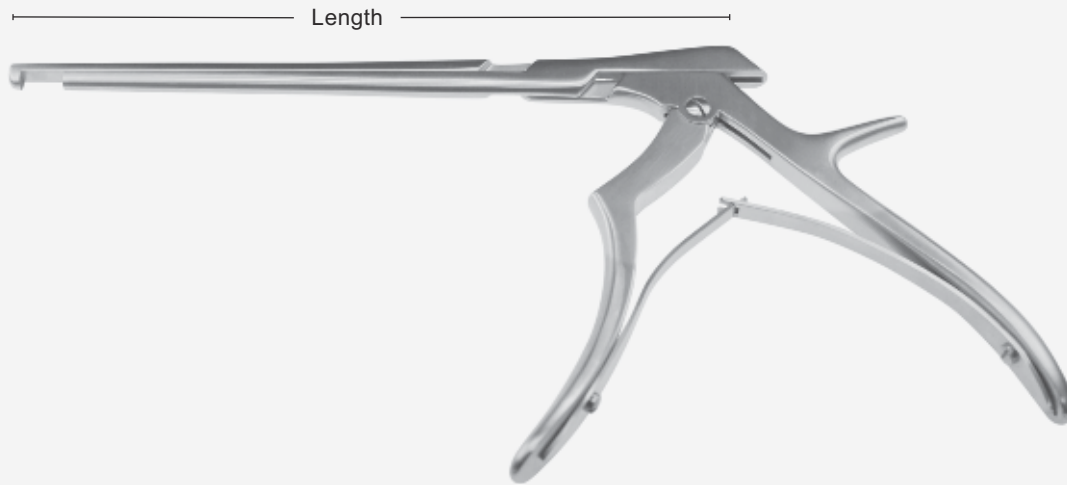

Standard handle



Love - Kerrison

Fig. 1

13-681-01
13-681-02
13-681-03
13-681-04
13-681-05
13-681-06
13-682-01
13-682-02
13-682-03
13-682-04
13-682-05
13-682-06

Upwards cutting 90°

Fig. 2

13-683-01
13-683-02
13-683-03
13-683-04
13-683-05
13-683-06
13-684-01
13-684-02
13-684-03
13-684-04
13-684-05
13-684-06

Upwards cutting 40°

Fig. 3

	Length
13-685-01	1 mm 18 cm / 7"
13-685-02	2 mm 18 cm / 7"
13-685-03	3 mm 18 cm / 7"
13-685-04	4 mm 18 cm / 7"
13-685-05	5 mm 18 cm / 7"
13-685-06	6 mm 18 cm / 7"
13-686-01	1 mm 20 cm / 8"
13-686-02	2 mm 20 cm / 8"
13-686-03	3 mm 20 cm / 8"
13-686-04	4 mm 20 cm / 8"
13-686-05	5 mm 20 cm / 8"
13-686-06	6 mm 20 cm / 8"

Upwards cutting 90°

**i** add "B" with catalogue part number if required in black TiN coating  
add "E" with catalogue part number if required with ejector

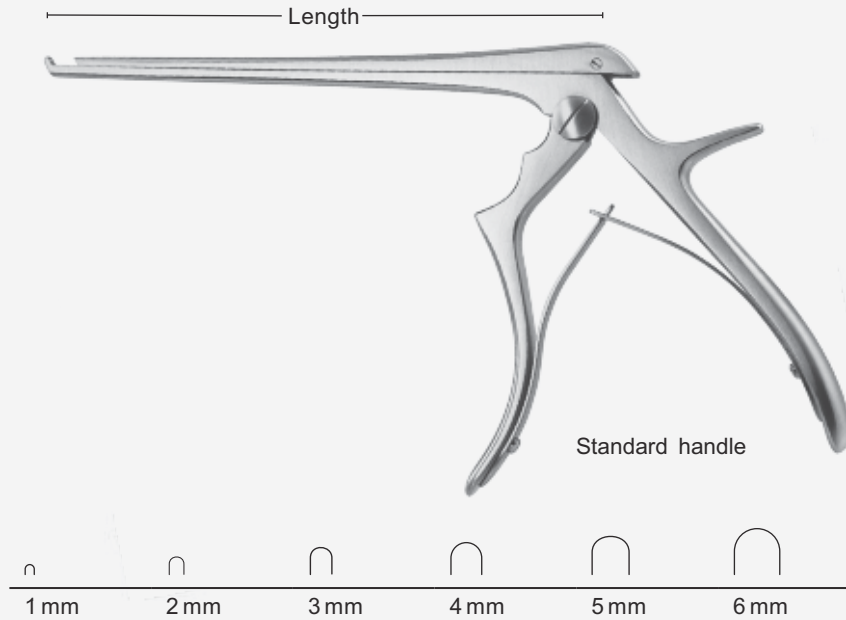

Kerrison Fig. 1	Fig. 2	Fig. 3	Fig. 4	Length
13-723-02	13-727-02	13-731-02	13-002-02	2 mm 15 cm / 6"
13-723-03	13-727-03	13-731-03	13-002-03	3 mm 15 cm / 6"
13-723-04	13-727-04	13-731-04	13-002-04	4 mm 15 cm / 6"
13-723-05	13-727-05	13-731-05	13-002-05	5 mm 15 cm / 6"
13-724-01	13-728-01	13-732-01	13-734-01	1 mm 18 cm / 7"
13-724-02	13-728-02	13-732-02	13-734-02	2 mm 18 cm / 7"
13-724-03	13-728-03	13-732-03	13-734-03	3 mm 18 cm / 7"
13-724-04	13-728-04	13-732-04	13-734-04	4 mm 18 cm / 7"
13-724-05	13-728-05	13-732-05	13-734-05	5 mm 18 cm / 7"
13-725-02	13-729-02	13-733-02	13-003-02	2 mm 20 cm / 8"
13-725-03	13-729-03	13-733-03	13-003-03	3 mm 20 cm / 8"
13-725-04	13-729-04	13-733-04	13-003-04	4 mm 20 cm / 8"
13-725-05	13-729-05	13-733-05	13-003-05	5 mm 20 cm / 8"
13-726-02	13-730-02	13-001-02	13-004-02	2 mm 23 cm / 9"
13-726-03	13-730-03	13-001-03	13-004-03	3 mm 23 cm / 9"
13-726-04	13-730-04	13-001-04	13-004-04	4 mm 23 cm / 9"
13-726-05	13-730-05	13-001-05	13-004-05	5 mm 23 cm / 9"
Upwards cutting 90° Thin footplate	Upwards cutting 40° Thin footplate	Downwards cutting 90° Thin footplate	Downwards cutting 40° Thin footplate	

**i** add "B" with catalogue part number if required in black TiN coating  
 add "E" with catalogue part number if required with ejector

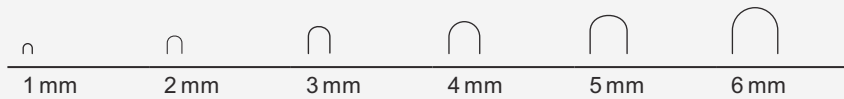
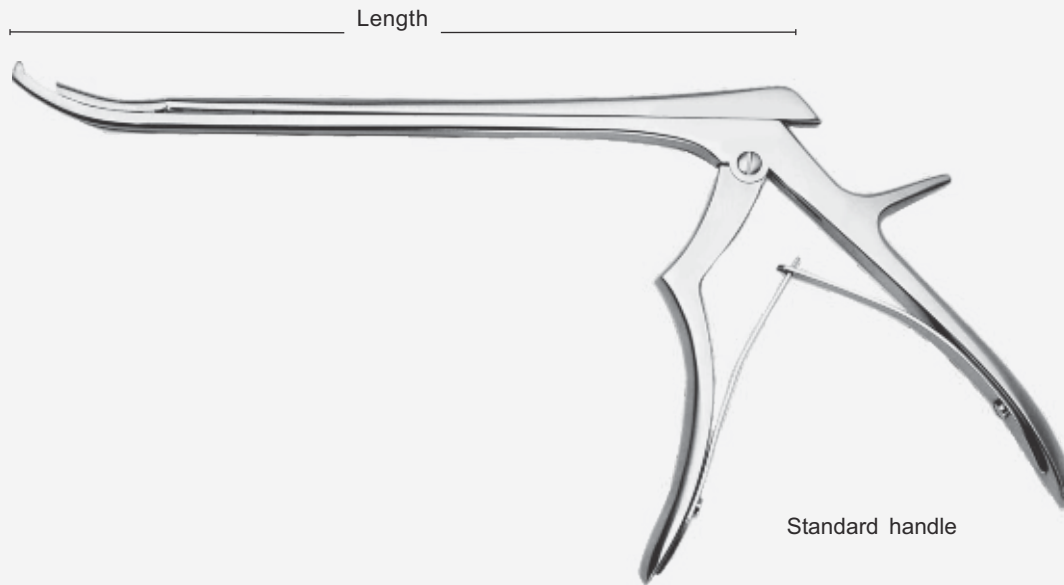

Fig. 1

Fig. 2

Kerrison  
Fig. 1

	Fig. 2		Length
13-735-01	13-738-01	1 mm	18 cm / 7"
13-736-01	13-739-01	1 mm	20 cm / 8"
13-737-01	13-740-01	1 mm	23 cm / 9"
13-735-02	13-738-02	2 mm	18 cm / 7"
13-736-02	13-739-02	2 mm	20 cm / 8"
13-737-02	13-740-02	2 mm	23 cm / 9"
13-735-03	13-738-03	3 mm	18 cm / 7"
13-736-03	13-739-03	3 mm	20 cm / 8"
13-737-03	13-740-03	3 mm	23 cm / 9"
13-735-04	13-738-04	4 mm	18 cm / 7"
13-736-04	13-739-04	4 mm	20 cm / 8"
13-737-04	13-740-04	4 mm	23 cm / 9"
13-735-05	13-738-05	5 mm	18 cm / 7"
13-736-05	13-739-05	5 mm	20 cm / 8"
13-737-05	13-740-05	5 mm	23 cm / 9"
13-735-06	13-738-06	6 mm	18 cm / 7"
13-736-06	13-739-06	6 mm	20 cm / 8"
13-737-06	13-740-06	6 mm	23 cm / 9"

Upwards cutting 40°

Downwards cutting 40°

Kerrison  
Fig. 1

	Fig. 2		Length
13-741-01	13-744-01	1 mm	18 cm / 7"
13-742-01	13-745-01	1 mm	20 cm / 8"
13-743-01	13-746-01	1 mm	23 cm / 9"
13-741-02	13-744-02	2 mm	18 cm / 7"
13-742-02	13-745-02	2 mm	20 cm / 8"
13-743-02	13-746-02	2 mm	23 cm / 9"
13-741-03	13-744-03	3 mm	18 cm / 7"
13-742-03	13-745-03	3 mm	20 cm / 8"
13-743-03	13-746-03	3 mm	23 cm / 9"
13-741-04	13-744-04	4 mm	18 cm / 7"
13-742-04	13-745-04	4 mm	20 cm / 8"
13-743-04	13-746-04	4 mm	23 cm / 9"
13-741-05	13-744-05	5 mm	18 cm / 7"
13-742-05	13-745-05	5 mm	20 cm / 8"
13-743-05	13-746-05	5 mm	23 cm / 9"
13-741-06	13-744-06	6 mm	18 cm / 7"
13-742-06	13-745-06	6 mm	20 cm / 8"
13-743-06	13-746-06	6 mm	23 cm / 9"

Upwards cutting 40°  
Bayonet

Downwards cutting 40°  
Bayonet

**i** add "B" with catalogue part number if required in black TiN coating  
add "E" with catalogue part number if required with ejector

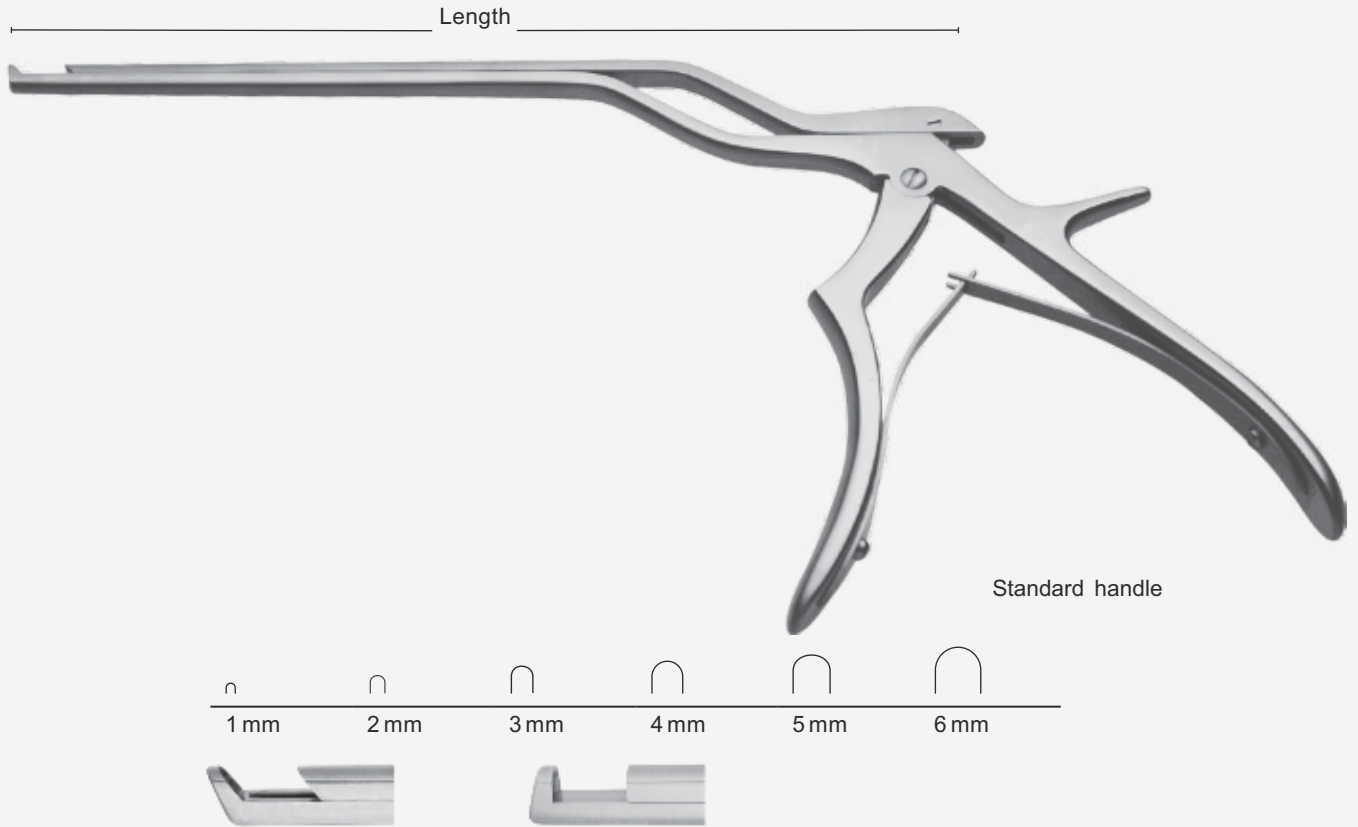

**Kerrison**

Fig. 1

13-747-01
13-748-01
13-749-01
13-747-02
13-748-02
13-749-02
13-747-03
13-748-03
13-749-03
13-747-04
13-748-04
13-749-04
13-747-05
13-748-05
13-749-05
13-747-06
13-748-06
13-749-06

Upwards cutting 40°

Fig. 2

Length

		Length
13-750-01	1 mm	11 cm / 4¼"
13-751-01	1 mm	15 cm / 6"
13-752-01	1 mm	18 cm / 7"
13-750-02	2 mm	11 cm / 4¼"
13-751-02	2 mm	15 cm / 6"
13-752-02	2 mm	18 cm / 7"
13-750-03	3 mm	11 cm / 4¼"
13-751-03	3 mm	15 cm / 6"
13-752-03	3 mm	18 cm / 7"
13-750-04	4 mm	11 cm / 4¼"
13-751-04	4 mm	15 cm / 6"
13-752-04	4 mm	18 cm / 7"
13-750-05	5 mm	11 cm / 4¼"
13-751-05	5 mm	15 cm / 6"
13-752-05	5 mm	18 cm / 7"
13-750-06	6 mm	11 cm / 4¼"
13-751-06	6 mm	15 cm / 6"
13-752-06	6 mm	18 cm / 7"

Upwards cutting 90°

**i** add "B" with catalogue part number if required in black TiN coating  
 add "E" with catalogue part number if required with ejector



Kerrison  
Fig. 1

13-753-01
13-754-01
13-755-01
13-753-02
13-754-02
13-755-02
13-753-03
13-754-03
13-755-03
13-753-04
13-754-04
13-755-04
13-753-05
13-754-05
13-755-05
13-753-06
13-754-06
13-755-06

Upwards cutting 40°  
Bayonet left



Fig. 2

13-756-01
13-757-01
13-758-01
13-756-02
13-757-02
13-758-02
13-756-03
13-757-03
13-758-03
13-756-04
13-757-04
13-758-04
13-756-05
13-757-05
13-758-05
13-756-06
13-757-06
13-758-06

Upwards cutting 90°  
Bayonet left



Fig. 3

13-759-01
13-760-01
13-761-01
13-759-02
13-760-02
13-761-02
13-759-03
13-760-03
13-761-03
13-759-04
13-760-04
13-761-04
13-759-05
13-760-05
13-761-05
13-759-06
13-760-06
13-761-06

Upwards cutting 40°  
Bayonet right

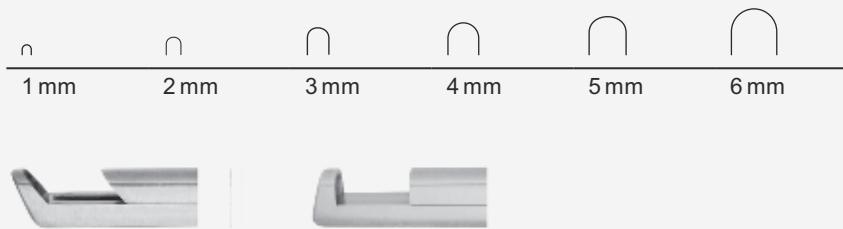
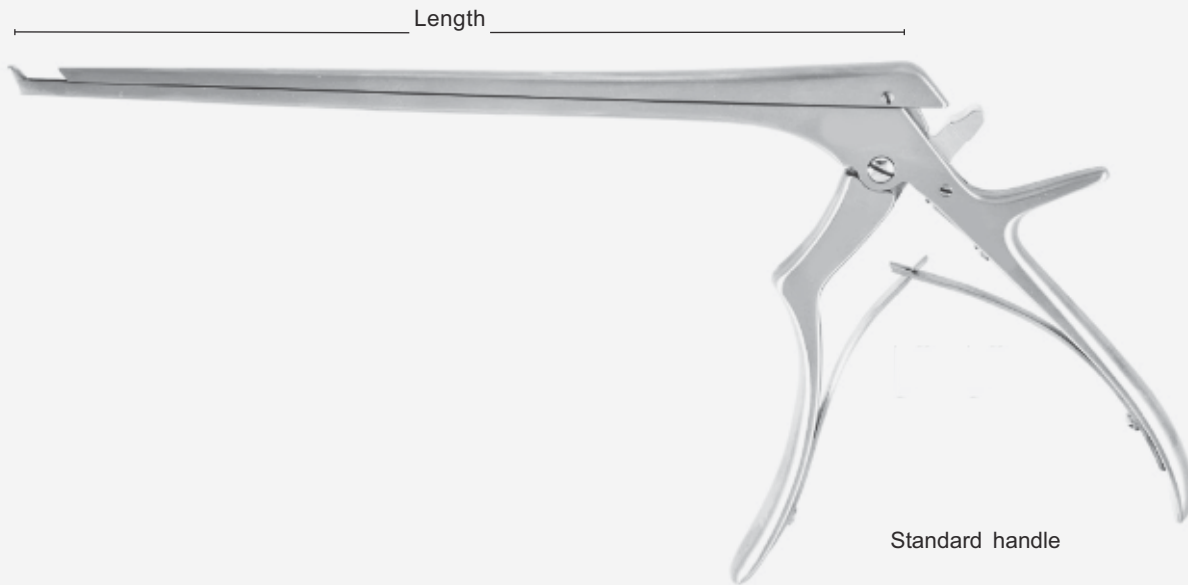

Fig. 4

		Length
13-762-01	1 mm	11 cm / 4¼"
13-763-01	1 mm	15 cm / 6"
13-764-01	1 mm	18 cm / 7"
13-762-02	2 mm	11 cm / 4¼"
13-763-02	2 mm	15 cm / 6"
13-764-02	2 mm	18 cm / 7"
13-762-03	3 mm	11 cm / 4¼"
13-763-03	3 mm	15 cm / 6"
13-764-03	3 mm	18 cm / 7"
13-762-04	4 mm	11 cm / 4¼"
13-763-04	4 mm	15 cm / 6"
13-764-04	4 mm	18 cm / 7"
13-762-05	5 mm	11 cm / 4¼"
13-763-05	5 mm	15 cm / 6"
13-764-05	5 mm	18 cm / 7"
13-762-06	6 mm	11 cm / 4¼"
13-763-06	6 mm	15 cm / 6"
13-764-06	6 mm	18 cm / 7"

Upwards cutting 90°  
Bayonet right

**i** add "B" with catalogue part number if required in black TiN coating  
add "E" with catalogue part number if required with ejector



**Kerrison Detachable**

Fig. 1	Fig. 2	Length
13-765-01	13-667-01	1 mm 18 cm / 7"
13-766-01	13-668-01	1 mm 23 cm / 9"
13-765-02	13-667-02	2 mm 18 cm / 7"
13-766-02	13-668-02	2 mm 23 cm / 9"
13-765-03	13-667-03	3 mm 18 cm / 7"
13-766-03	13-668-03	3 mm 23 cm / 9"
13-765-04	13-667-04	4 mm 18 cm / 7"
13-766-04	13-668-04	4 mm 23 cm / 9"
13-765-05	13-667-05	5 mm 18 cm / 7"
13-766-05	13-668-05	5 mm 23 cm / 9"
13-765-06	13-667-06	6 mm 18 cm / 7"
13-766-06	13-668-06	6 mm 23 cm / 9"



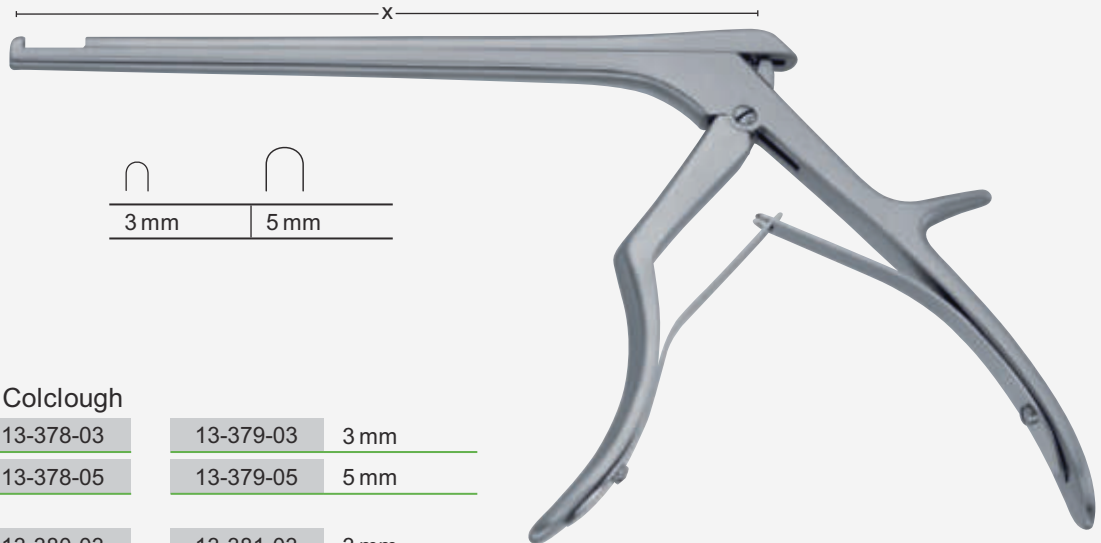

Upwards cutting 40°

Upwards cutting 90°

**i** add "B" with catalogue part number if required in black TiN coating  
 add "E" with catalogue part number if required with ejector

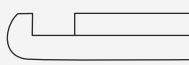

**Colclough**

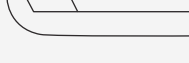
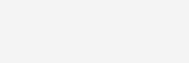
	13-378-03	13-379-03	3 mm
	13-378-05	13-379-05	5 mm
	13-380-03	13-381-03	3 mm
	13-380-05	13-381-05	5 mm
	13-382-03	13-383-03	3 mm
	13-382-05	13-383-05	5 mm
	x = 15 cm - 6"	x = 20 cm - 8"	

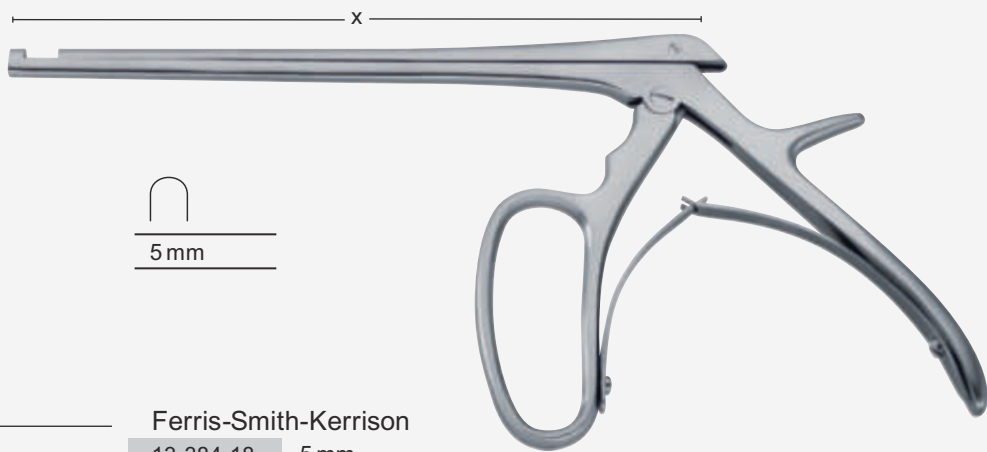

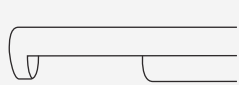
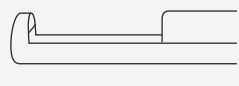
	<b>Ferris-Smith-Kerrison</b>	13-384-18	5 mm
		13-385-18	5 mm
		x = 18 cm - 7"	

**i** add "B" with catalogue part number if required in black TIN coating  
add "E" with catalogue part number if required with ejector





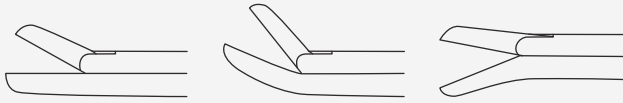

	<b>Cushing</b>			
	13-386-13	13-387-13	13-388-13	x = 13 cm - 5"
	13-386-18	13-387-18	13-388-18	x = 18 cm - 7"
	13-386-22	13-387-22	13-388-22	x = 22 cm - 8 3/4"
	2 mm x 10 mm	2 mm x 10 mm	2 mm x 10 mm	
	<b>Love-Gruenwald</b>			
	13-389-13	13-390-13	13-391-13	x = 13 cm - 5"
	13-389-18	13-390-18	13-391-18	x = 18 cm - 7"
	13-389-22	13-390-22	13-391-22	x = 22 cm - 8 3/4"
	3 mmx10 mm	3 mmx10 mm	3 mmx10 mm	
	<b>Spurling</b>			
	13-392-13	13-393-13	13-394-13	x = 13 cm - 5"
	13-392-18	13-393-18	13-394-18	x = 18 cm - 7"
	13-392-22	13-393-22	13-394-22	x = 22 cm - 8 3/4"
	4 mm x 10 mm	4 mm x 10 mm	4 mm x 10 mm	
	<b>Cloward</b>			
	13-395-18	x = 18 cm - 7"		
	6 mm x 10 mm			







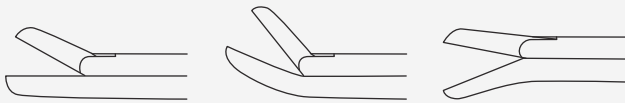

**Ferris-Smith**

	13-396-02	13-397-02	13-398-02	2 mm x 10 mm
	13-396-03	13-397-03	13-398-03	3 mm x 10 mm
	13-396-04	13-397-04	13-398-04	4 mm x 10 mm
	13-396-06	13-397-06	13-398-06	6 mm x 10 mm
	x = 18 cm - 7"	x = 18 cm - 7"	x = 18 cm - 7"	

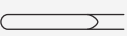

**Caspar**

	13-399-02	13-400-02	13-401-02	2 mm
	13-399-03	13-400-03	13-401-03	3 mm
	13-399-04	13-400-04	13-401-04	4 mm
	13-399-05	13-400-05	13-401-05	5 mm
	x = 15.5 cm - 6"	x = 15.5 cm - 6"	x = 15.5 cm - 6"	



**Oldenberg**

13-402-17

13-403-17

17 cm - 6 3/4"

3.5 mm Ø

6.0 mm Ø

x = 180 mm - 7"

x = 180 mm - 7"



**Schlesinger**

13-404-19

19 cm - 7 1/2"

13-404-21

21.5 cm - 8 1/2"

3 mm x 10 mm

x = 125 mm - 5"

saw edge

gezahnt

dentada

dentelé

dentata



**Caspar**

13-405-02	13-406-02	13-407-02	2 mm x 12 mm
13-405-03	13-406-03	13-407-03	3 mm x 12 mm
13-405-04	13-406-04	13-407-04	4 mm x 14 mm
13-405-05	13-406-05	13-407-05	5 mm x 14 mm
13-405-06	13-406-06	13-407-06	6 mm x 16 mm

x = 14 cm - 5 1/2"

x = 16 cm - 6 1/4"

x = 18.5 cm - 7 1/4"



13-408-02	13-409-02	13-410-02	2 mm x 12 mm
13-408-04	13-409-04	13-410-04	4 mm x 14 mm
13-408-05	13-409-05	13-410-05	5 mm x 14 mm
13-408-06	13-409-06	13-410-06	6 mm x 16 mm

x = 14 cm - 5 1/2"

x = 16 cm - 6 1/4"

x = 18.5 cm - 7 1/4"



13-411-05	13-412-05	13-413-05	5 mm x 14 mm
13-411-06	13-412-06	13-413-06	6 mm x 16 mm

x = 14 cm - 5 1/2"



x = 16 cm - 6 1/4"

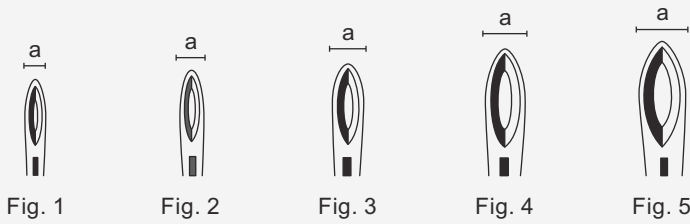

x = 18.5 cm - 7 1/4"

Jaw fenestrated and serrated  
Maul gefenstert und gezahnt  
Boca con orificio y dentada  
Mors fenêtré et dentelé  
Morso finestrato e dentellato



**Weil-Blakesley**

	18-288-12 a = 3.0mm	18-289-12 a = 3.5mm	18-290-12 a = 4.5mm	18-291-12 a = 5.0mm	18-292-12 a = 5.5mm	x = 12 cm - 4 ¾"
	18-293-00 a = 3.0mm	18-294-00 a = 3.5mm	18-295-00 a = 4.5mm	18-296-00 a = 5.0mm		
	18-297-00 a = 3.0mm	18-298-00 a = 3.5mm	18-299-00 a = 4.5mm			

	Fig. 1 18-300-18 a = 3.0mm	Fig. 2 18-301-18 a = 3.5mm	Fig. 3 18-302-18 a = 4.5mm	Fig. 4 18-303-18 a = 5.0mm	Fig. 5 18-304-18 a = 5.5mm	x = 18 cm - 7"
	18-305-18 a = 3.0mm	18-306-18 a = 3.5mm	18-307-18 a = 4.5mm	18-308-18 a = 5.0mm		x = 18 cm - 7"



**Cloward**

08-160-16	Retractor only	16 cm - 6 1/4"
08-160-00	Complete set consisting of:	
	1 Retractor	
	1 pair of blades 08-164-01 to 08-164-05	



08-161-25	Retractor only	25 cm - 9 3/4"
08-161-00	Complete set consisting of:	
	1 Retractor	
	1 pair of blades 08-164-01 to 08-164-05	



08-164-01	Fig.1	x = 60 mm
08-164-02	Fig.2	x = 55 mm
08-164-03	Fig.3	x = 50 mm
08-164-04	Fig.4	x = 45 mm
08-164-05	Fig.5	x = 40 mm

Non toothed  
Nicht gezahnt  
No dentada  
Non denté  
Non dentato



08-165-01	Fig.1	x = 60 mm
08-165-02	Fig.2	x = 55 mm
08-165-03	Fig.3	x = 50 mm
08-165-04	Fig.4	x = 45 mm
08-165-05	Fig.5	x = 40 mm

Toothed  
Gezahnt  
Dentada  
Dentelée  
Dentata

Laminectomy retractors  
 Laminektomiesperrer  
 Separadores para laminectomia  
 Ecarteurs pour laminectomie  
 divaricatori per laminectomia



Cloward - Hoern

13-867-25	Retractor only	25 cm - 10"
13-867-00	Complete set consisting of:	
13-867-25	1 Retractor	
	1 pair of blades 13-858-50 to 13-868-64	

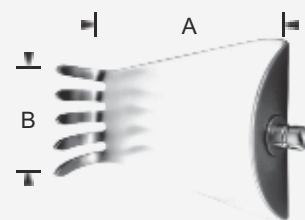

Cloward - Hoern

A B

13-868-50	50x31mm
13-868-64	64x31mm



Caspar  
Fig. 1

13-878-01	Retractor only
13-878-00	Complete set consisting of:
13-878-01	1 Retractor
	1 pair of blades 13-888-45 to 13-888-65



Caspar  
Fig. 2

13-879-01	Retractor only
13-879-00	Complete set consisting of:
13-879-01	1 Retractor
	1 pair of blades 13-888-45 to 13-888-65

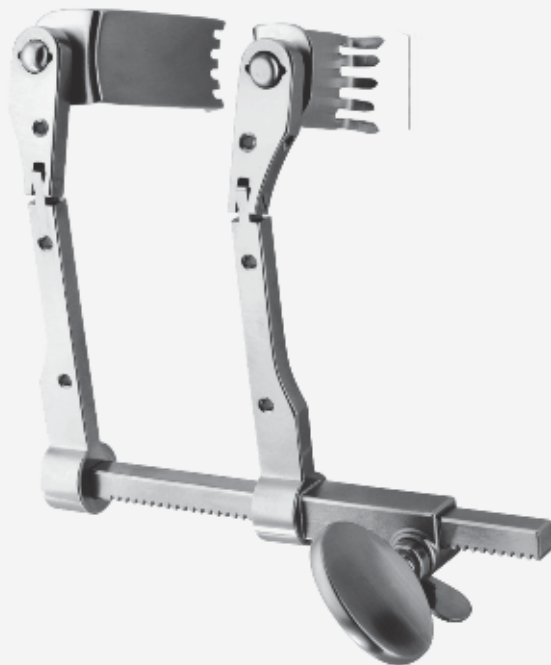

Caspar  
Fig. 3

13-880-03	Retractor only
13-880-00	Complete set consisting of:
13-880-03	1 Retractor
	1 pair of blades 13-884-40 to 13-884-60
	1 pair of blades 13-885-40 to 13-885-60

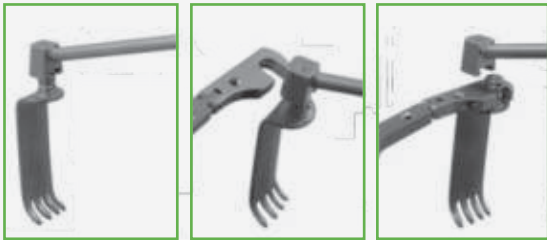

**Blade Opener**

13-881-11

11.5 cm - 4 1/2"

Forceps for changing the blades



**Blade Inserter**

13-882-20

20 cm - 8"

Ferrozell handle

13-883-20

20 cm - 8"

Propylux handle

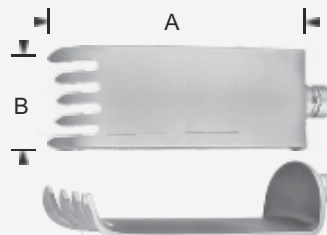

**5 Prongs Blade** A B

13-884-40	40x23 mm
13-884-45	45x23 mm
13-884-50	50x23 mm
13-884-55	55x23 mm
13-884-60	60x23 mm
13-884-65	65x23 mm
13-884-75	75x23 mm

Medial

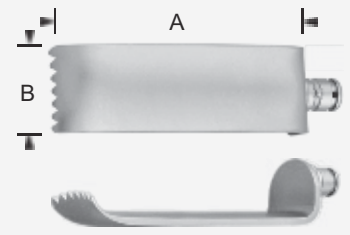

**Toothed Blade** A B

13-885-40	40x23 mm
13-885-45	45x23 mm
13-885-50	50x23 mm
13-885-55	55x23 mm
13-885-60	60x23 mm
13-885-65	65x23 mm
13-885-75	75x23 mm

Lateral

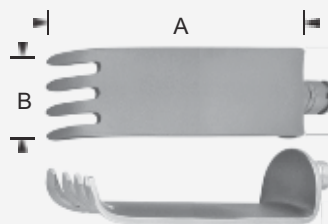

**4 Prongs Blade** A B

13-886-40	40x23 mm
13-886-45	45x23 mm
13-886-50	50x23 mm
13-886-55	55x23 mm
13-886-60	60x23 mm
13-886-65	65x23 mm

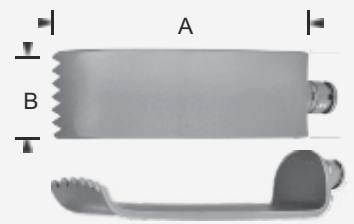

**Toothed Blade** A B

13-887-40	40x23 mm
13-887-45	45x23 mm
13-887-50	50x23 mm
13-887-55	55x23 mm
13-887-60	60x23 mm
13-887-65	65x23 mm



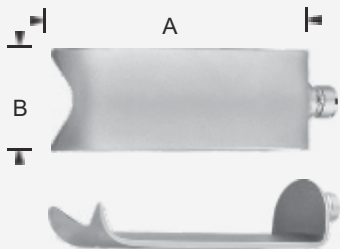

Concave Blade	A	B
13-888-40	40 x 23 mm	
13-888-45	45 x 23 mm	
13-888-50	50 x 23 mm	
13-888-55	55 x 23 mm	
13-888-60	60 x 23 mm	
13-888-65	65 x 23 mm	
13-888-70	70 x 23 mm	
13-888-75	75 x 23 mm	

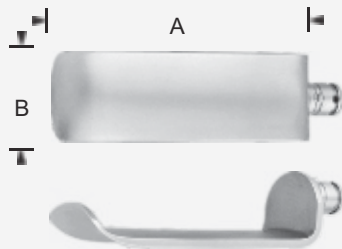

Blunt Blade	A	B
13-889-40	40 x 23 mm	
13-889-45	45 x 23 mm	
13-889-50	50 x 23 mm	
13-889-55	55 x 23 mm	
13-889-60	60 x 23 mm	
13-889-65	65 x 23 mm	

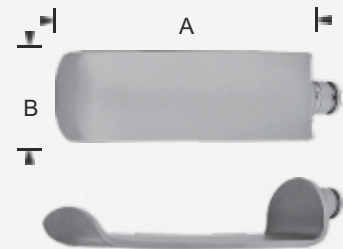

Blunt Blade	A	B
13-890-30	30 x 20 mm	
13-890-35	35 x 20 mm	
13-890-40	40 x 20 mm	
13-890-45	45 x 20 mm	
13-890-50	50 x 20 mm	
13-890-55	55 x 20 mm	
13-890-60	60 x 20 mm	
13-890-65	65 x 20 mm	
13-890-70	70 x 20 mm	
13-890-75	75 x 20 mm	

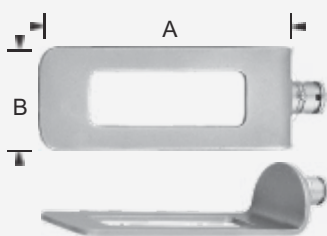

Blunt Blade	A	B
13-891-50	50 x 25 mm	
13-891-60	60 x 25 mm	

Blades for harvesting of the fusion graft from the iliac crest, blunt

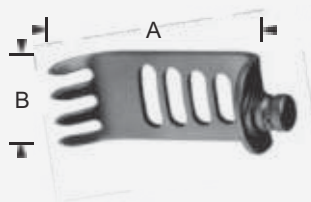

Fenestrated Blade Fig. 1	A	B
13-892-25	25 x 20 mm	
13-892-30	30 x 20 mm	
13-892-35	35 x 20 mm	
13-892-40	40 x 20 mm	
13-892-45	45 x 20 mm	
13-892-50	50 x 20 mm	
13-892-55	55 x 20 mm	
13-892-60	60 x 20 mm	
13-892-65	65 x 20 mm	
13-892-70	70 x 20 mm	

Medial

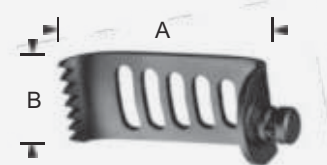

Fenestrated Blade Fig. 2	A	B
13-893-25	25 x 20 mm	
13-893-30	30 x 20 mm	
13-893-35	35 x 20 mm	
13-893-40	40 x 20 mm	
13-893-45	45 x 20 mm	
13-893-50	50 x 20 mm	
13-893-55	55 x 20 mm	
13-893-60	60 x 20 mm	
13-893-65	65 x 20 mm	
13-893-70	70 x 20 mm	

Lateral



Cervical Spin  
 Fig. 1

13-894-13	Retractor only	13.5 cm - 5 1/4"
13-894-00	Complete set consisting of:	
13-894-13	1 Retractor	
	1 pair of blades 13-884-40 to 13-884-60	
	1 pair of blades 13-885-40 to 13-885-60	

Transverse retractor, double hinged



Cervical Spin  
 Fig. 2

13-895-20	Retractor only	20 cm - 8"
13-895-00	Complete set consisting of:	
13-895-20	1 Retractor	
	1 pair of blades 13-884-40 to 13-884-60	
	1 pair of blades 13-885-40 to 13-885-60	

Transverse retractor, double hinged

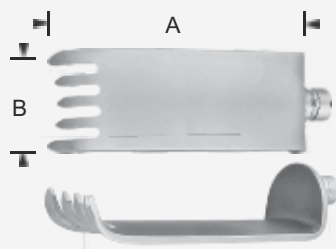

5 Prongs Blade	A	B
13-884-40	40 x 23 mm	
13-884-45	45 x 23 mm	
13-884-50	50 x 23 mm	
13-884-55	55 x 23 mm	
13-884-60	60 x 23 mm	
13-884-65	65 x 23 mm	
13-884-75	75 x 23 mm	

Medial

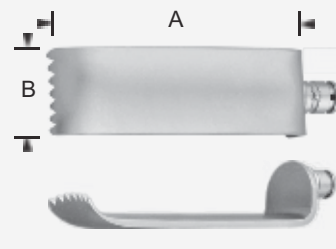

Toothed Blade	A	B
13-885-40	40 x 23 mm	
13-885-45	45 x 23 mm	
13-885-50	50 x 23 mm	
13-885-55	55 x 23 mm	
13-885-60	60 x 23 mm	
13-885-65	65 x 23 mm	
13-885-75	75 x 23 mm	

Lateral



Cervical Spin

Fig. 3

		A	
13-896-17	Retractor only	90mm	17 cm - 6 3/4"
13-896-00	Complete set consisting of:		
13-896-17	1 Retractor		
	1 pair of blades 13-884-40 to 13-884-60		
	1 pair of blades 13-885-40 to 13-885-60		

Retractor, double hinged, open blade reception

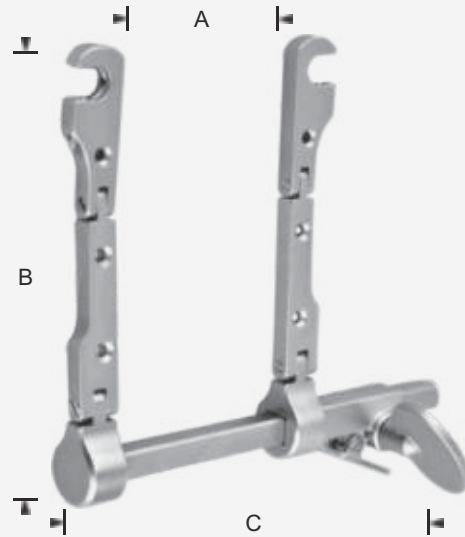

Cervical Spin

Fig. 4

		A	B	C	
13-897-11	Retractor only	90mm	115mm	130mm	11.5 cm - 4 1/2"
13-897-00	Complete set consisting of:				
13-897-11	1 Retractor				
	1 pair of blades 13-884-40 to 13-884-60				
	1 pair of blades 13-885-40 to 13-885-60				

Retractor, double hinged, open blade reception

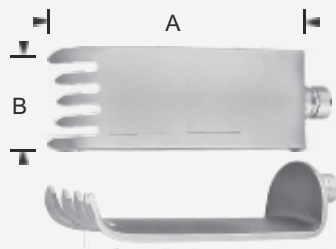

5 Prongs Blade

	A	B
13-884-40	40 x 23 mm	
13-884-45	45 x 23 mm	
13-884-50	50 x 23 mm	
13-884-55	55 x 23 mm	
13-884-60	60 x 23 mm	
13-884-65	65 x 23 mm	
13-884-75	75 x 23 mm	

Medial

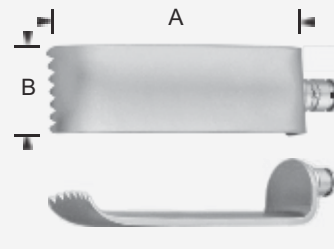

Toothed Blade

	A	B
13-885-40	40 x 23 mm	
13-885-45	45 x 23 mm	
13-885-50	50 x 23 mm	
13-885-55	55 x 23 mm	
13-885-60	60 x 23 mm	
13-885-65	65 x 23 mm	
13-885-75	75 x 23 mm	

Lateral



Cervical Spin  
 Fig. 5

13-898-13	Retractor only	13.5 cm - 5 1/4"
13-898-00	Complete set consisting of:	
13-898-13	1 Retractor	
	1 pair of blades 13-900-40 to 13-900-60	
	1 pair of blades 13-901-40 to 13-901-60	
	1 pair of blades 13-902-40 to 13-902-60	

Transverse retractor, double hinged



Cervical Spin  
 Fig. 6

13-899-20	Retractor only	20 cm - 8"
13-899-00	Complete set consisting of:	
13-899-20	1 Retractor	
	1 pair of blades 13-900-40 to 13-900-60	
	1 pair of blades 13-901-40 to 13-901-60	
	1 pair of blades 13-902-40 to 13-902-60	

Transverse retractor, double hinged

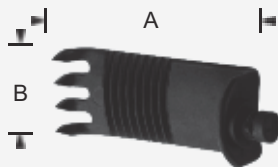

	A	B
13-900-40	40 x 23 mm	
13-900-45	45 x 23 mm	
13-900-50	50 x 23 mm	
13-900-55	55 x 23 mm	
13-900-60	60 x 23 mm	
13-900-65	65 x 23 mm	
13-900-70	70 x 23 mm	
13-900-75	75 x 23 mm	

Blades, medial

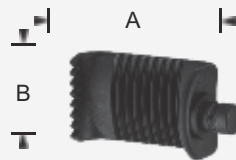

	A	B
13-901-40	40 x 23 mm	
13-901-45	45 x 23 mm	
13-901-50	50 x 23 mm	
13-901-55	55 x 23 mm	
13-901-60	60 x 23 mm	
13-901-65	65 x 23 mm	
13-901-70	70 x 23 mm	
13-901-75	75 x 23 mm	

Blades, lateral

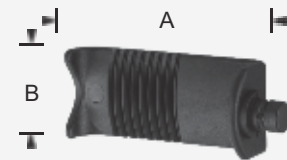

	A	B
13-902-40	40 x 23 mm	
13-902-45	45 x 23 mm	
13-902-50	50 x 23 mm	
13-902-55	55 x 23 mm	
13-902-60	60 x 23 mm	
13-902-65	65 x 23 mm	
13-902-70	70 x 23 mm	
13-902-75	75 x 23 mm	

Blades, blunt



Mc Culloch

13-903-01

Rigid

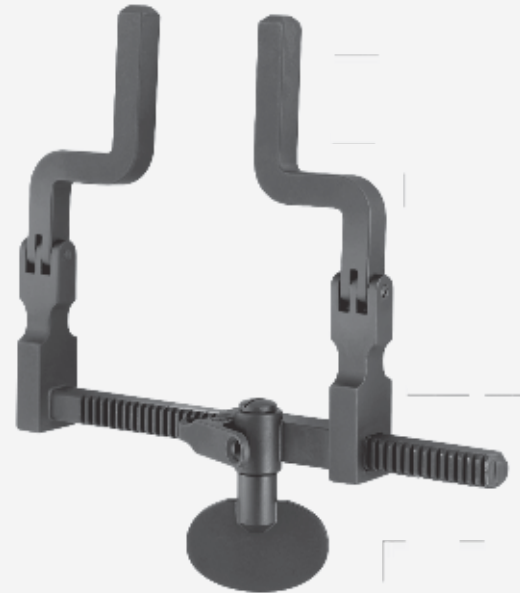

Mc Culloch

13-904-01

Retractor only

13-904-00

Complete set consisting of:

13-904-01

1 Retractor

1 pair of blades 13-905-40 to 13-905-60

1 pair of blades 13-906-40 to 13-906-60

1 pair of blades 13-907-40 to 13-907-60

21-545-03

1 Wire basket 540 x 255 x 70mm

21-627-04

2 Silicone mats 380 x 230 mm

Hinged

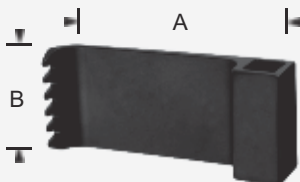

A B

13-905-30	30 x 23 mm	1 piece
13-905-40	40 x 23 mm	1 piece
13-905-50	50 x 23 mm	1 piece
13-905-60	60 x 23 mm	1 piece
13-905-70	70 x 23 mm	1 piece
13-905-80	80 x 23 mm	1 piece
13-905-00	Set	1 pair each

Muscle blades, wide



A B

13-906-30	30 x 20 mm	1 piece
13-906-40	40 x 20 mm	1 piece
13-906-50	50 x 20 mm	1 piece
13-906-60	60 x 20 mm	1 piece
13-906-70	70 x 20 mm	1 piece
13-906-80	80 x 20 mm	1 piece
13-906-00	Set	1 pair each

Muscle blades, narrow

**i** add "C" with catalogue part number if required in black ceramic coating

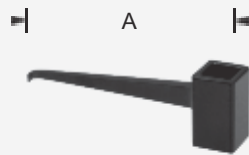

	A	
13-907-20	20 mm	1 piece
13-907-30	30 mm	1 piece
13-907-40	40 mm	1 piece
13-907-50	50 mm	1 piece
13-907-60	60 mm	1 piece
13-907-70	70 mm	1 piece
13-907-00	Set	1 pair each

Hook blades



	A	
13-908-20	20 mm	1 piece
13-908-30	30 mm	1 piece
13-908-40	40 mm	1 piece
13-908-50	50 mm	1 piece
13-908-60	60 mm	1 piece
13-908-70	70 mm	1 piece
13-908-00	Set	1 pair each

Hook blades



	A B	
13-909-30	30 x 17 mm	1 piece
13-909-40	40 x 17 mm	1 piece
13-909-50	50 x 17 mm	1 piece
13-909-60	60 x 17 mm	1 piece
13-909-70	70 x 17 mm	1 piece
13-909-80	80 x 17 mm	1 piece
13-909-00	Set	1 pair each

Thin muscle blades

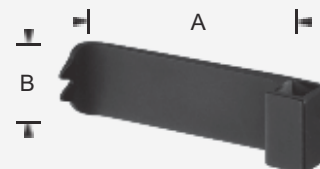

	A B	
13-910-50	50 x 20 mm	1 piece
13-910-60	60 x 20 mm	1 piece
13-910-70	70 x 20 mm	1 piece
13-910-00	Set	1 pair each

Cervical blades

**i** add "C" with catalogue part number if required in black ceramic coating



Caspar	Blade length
13-911-40	40 mm
13-911-45	45 mm
13-911-50	50 mm
13-911-55	55 mm
13-911-60	60 mm
13-911-65	65 mm
13-911-70	70 mm
13-911-75	75 mm
13-911-85	85 mm

Specula



Caspar  
13-912-00

Counter retractor frame



	A B
13-913-35	35 x 15 mm
13-913-40	40 x 15 mm
13-913-45	45 x 15 mm
13-913-50	50 x 15 mm
13-913-55	55 x 15 mm
13-913-60	60 x 15 mm
13-913-65	65 x 15 mm
13-913-70	70 x 15 mm
13-913-75	75 x 15 mm
13-913-85	85 x 15 mm

Blades, lateral

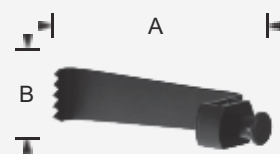

	A B
13-914-40	40 x 15 mm
13-914-45	45 x 15 mm
13-914-50	50 x 15 mm
13-914-55	55 x 15 mm
13-914-60	60 x 15 mm
13-914-65	65 x 15 mm
13-914-70	70 x 15 mm

Blades, medial

**i** add "C" with catalogue part number if required in black ceramic coating

**i** Vertebral body distractor, for use in surgical procedures from the left approach for C5 through T1/2 and from the right approach for the upper cervical spine.



**Cervical Body Distractor, Left**  
 13-915-00

Vertebral body distractor left only with standard prolonged toothed bar (length 113 mm)



**Drill Guide, Left**  
 13-916-00

Drill guide, for parallel positioning of the distraction screws, to be used with distractor 13-915-00

**i** Vertebral body distractor, for use in surgical procedures from the right approach for C5 through T1/2 and from the left approach for the upper cervical spine.



**Cervical Body Distractor, Right**  
 13-917-00

Vertebral body distractor right only with standard prolonged toothed bar (length 113 mm)



**Drill Guide, Right**  
 13-918-00

Drill guide, for parallel positioning of the distraction screws, to be used with distractor 13-917-00





**Cervical Body Distractor, Left**  
13-919-00

Spreading right, 110 mm wide,  
total opening 70 mm,  
depths of shank 60 mm



**Cervical Body Distractor, Right**  
13-920-00

Spreading left, 110 mm wide,  
total opening 70 mm,  
depths of shank 60 mm



**Distraction Screw**

13-921-12	12 mm
13-921-14	14 mm
13-921-16	16 mm
13-921-18	18 mm

7 cm - 2 3/4"  
Distraction screws  
to be used with distractors  
13-915-00 and 13-917-00  
at least 2 each are required  
Packing unit of 2 pieces



**Distraction Screw Modified A**

13-922-12	90 mm	12 mm
13-922-14	92 mm	14 mm
13-922-16	94 mm	16 mm



**Twist Drill**  
13-923-14

14.5 cm - 5 3/4"  
Ø 1.7 mm,  
for pre-drilling holes for  
distraction screws,  
Drilling depth: 8 mm,  
sheath Ø 2.35 mm



**Screw Driver**

13-924-01 20 cm - 8"

For distraction screws  
 Ferrozell handle

13-924-02 20 cm - 8"

For distraction screws  
 Propylux handle



**Bone Graft Holder**

13-925-01 22 cm - 8 3/4"

Insertion instrument  
 Ferrozell handle

13-925-02 22 cm - 8 3/4"

Insertion instrument  
 Propylux handle



Fig. 1

Fig. 2

**Dissector**

13-926-01 Fig. 1

13-926-02 Fig. 2



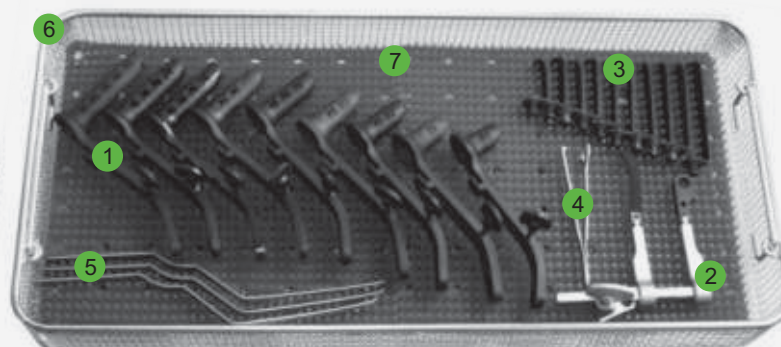

20.5 cm - 8"  
 Vertebral body dissectors  
 Ferrozell handle





	Item No.	Description
	<b>Cervical Retractor Set</b> 13-927-00	Set consisting of:
	13-878-01	1 Caspar Retractor Fig. 1
	13-879-02	1 Caspar Retractor Fig. 3
	13-880-03	2 Micro forceps straight 18 cm - 7"
	13-179-18	1 Micro forceps straight 18 cm - 7"
	13-892-25 to 13-892-70	1 pair of blades
	13-893-40 to 13-893-70	1 pair of blades
	13-890-30 to 13-890-75	1 pair of blades
	13-881-00	1 Forceps for changing the blades with ball snap closure
	21-545-03	1 Wire basket 540 x 255 x 70 mm
	21-627-04	2 Silicone mats 380 x 230 mm



	Item No.	Description
	<b>Micro Discectomy Set Fig. 1</b> 13-928-00	Set consisting of:
1	13-911-40 to 13-911-85	1 pair of blades
2	13-912-00	1 Caspar Counter Retractor Frame
3	13-913-35 to 13-913-85	2 Micro forceps straight 18 cm - 7"
4	13-881-00	1 Forceps for changing the blades with ball snap closure
5	13-227-06 to 13-227-10	Caspar nerve root retractors
6	21-515-03	1 Wire basket 540 x 255 x 70 mm
7	21-627-04	2 Silicone mats 380 x 230 mm

	Item No.	Description
	<b>Micro Discectomy Set Fig. 2</b> 13-929-00	Set consisting of:
1	13-911-40 to 13-911-85	1 pair of blades
2	13-912-00	1 Caspar Counter Retractor Frame
3	13-913-35 to 13-913-85	2 Micro forceps straight 18 cm - 7"
4	13-881-00	1 Forceps for changing the blades with ball snap closure
6	21-515-03	1 Wire basket 540 x 255 x 70 mm
7	21-627-04	2 Silicone mats 380 x 230 mm

	Item No.	Description
	Micro Disectomy Set Fig. 3 13-930-00	Set consisting of:
	13-917-00	1 Caspar Retractor Fig. 1
	13-918-00	1 Drill guide, right
	13-924-01	1 Screw driver
	13-923-14	1 Twist drill
	13-921-14	10 pcs Distraction screws

	Item No.	Description
	Micro Disectomy Set Fig. 4 13-931-00	Set consisting of:
	13-912-00	1 Caspar counter retractor frame
	13-911-40 to 13-911-85	1 pair of blades
	13-913-40 to 13-913-85	1 pair of blades
	13-881-00	1 Forceps for changing the blades with ball snap closure

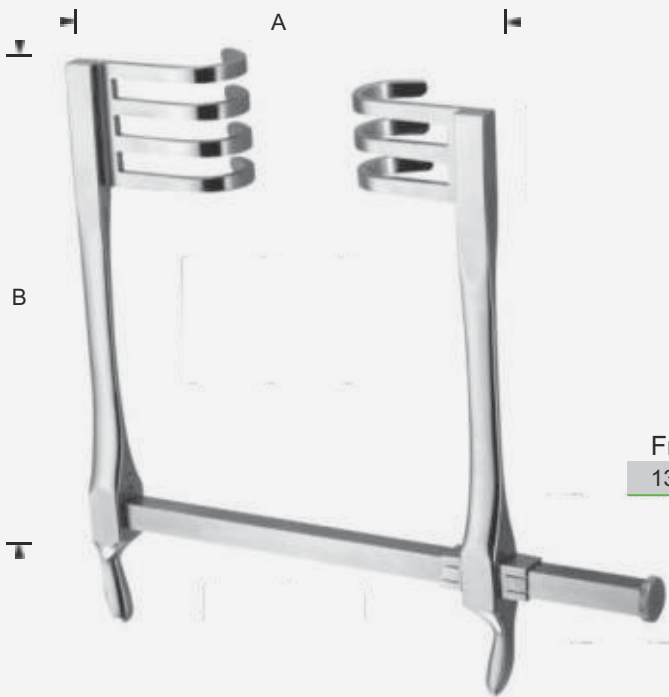

Frazier	A	B
13-932-50	16.5 cm - 6 1/2"	13 cm - 5"

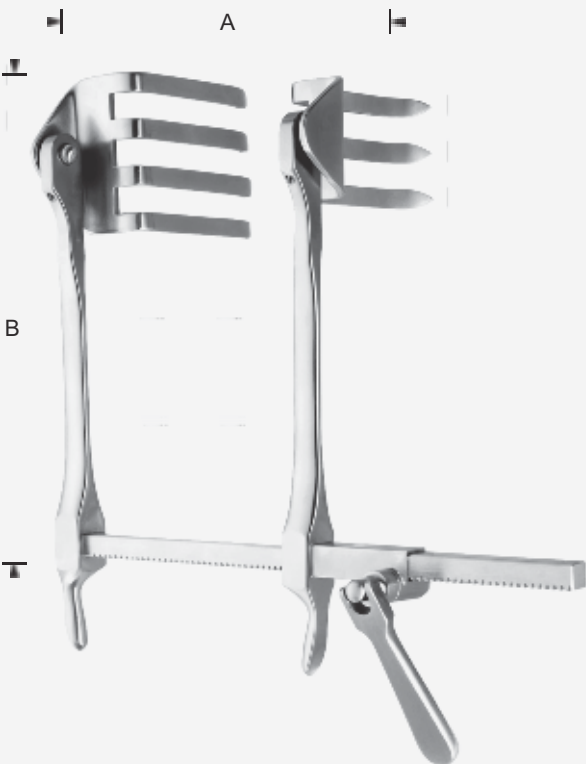

Scoville - Richter	A	B
13-933-01	14 cm - 5 1/2"	17 cm - 6 3/4"
13-933-00	Complete set consisting of:	
13-933-01	1 Retractor	17 cm - 6 3/4"
	13-934-01 to 13-934-02	
	1 pair of each	

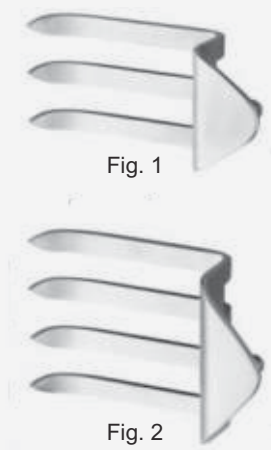

Scoville - Richter		
13-934-01	Fig. 1	60 x 37 mm
13-934-02	Fig. 2	60 x 50 mm
1 pair of blades		



Fig. 3



Fig. 4

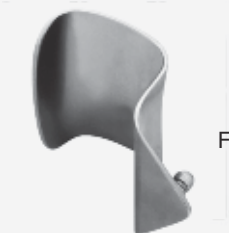
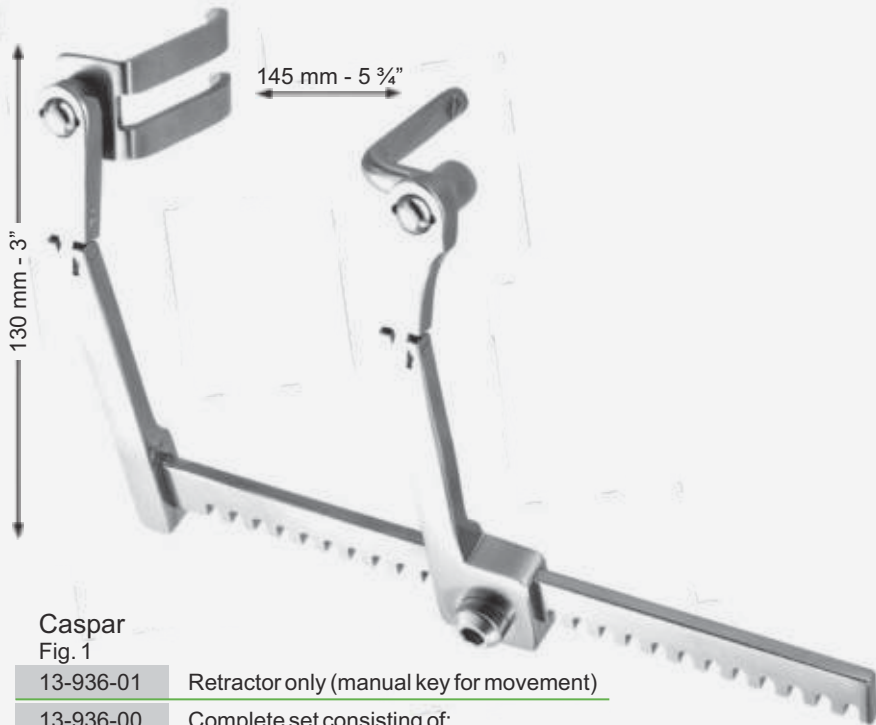

Fig. 5

Scoville - Richter		
13-935-03	Fig. 3	48 x 50 mm
13-935-04	Fig. 4	28 x 40 mm
13-935-05	Fig. 5	38 x 62 mm
1 pair of blades		



Caspar  
Fig. 1

13-936-01	Retractor only (manual key for movement)
13-936-00	Complete set consisting of:
13-936-01	1 Retractor
13-938-58	1 Hook 58 mm
13-937-00	Key for retractor movement
	1 pair of each, 13-940-37 and 13-941-41



Key  
13-937-00



Hook  
13-938-38 38 mm  
13-938-58 58 mm

Caspar  
Fig. 2

13-936-02	Retractor only (attached key for movement)
13-936-00	Complete set consisting of:
13-936-01	1 Retractor
13-938-38	1 Hook 38 mm
	1 pair of each, 13-941-37 to 13-941-57



Blade	A	B
Fig. 1		
13-939-32	32 x 52 mm	1 piece
13-939-37	37 x 52 mm	1 piece
13-939-42	42 x 52 mm	1 piece
13-939-47	32 x 52 mm	1 piece
13-939-52	52 x 52 mm	1 piece
13-939-57	57 x 52 mm	1 piece
13-939-65	65 x 52 mm	1 piece
13-939-67	67 x 52 mm	1 piece



Blade	A	B
Fig. 2		
13-940-32	32 x 52 mm	1 piece
13-940-37	37 x 52 mm	1 piece
13-940-42	42 x 52 mm	1 piece
13-940-47	32 x 52 mm	1 piece
13-940-52	52 x 52 mm	1 piece
13-940-57	57 x 52 mm	1 piece
13-940-65	65 x 52 mm	1 piece
13-940-67	67 x 52 mm	1 piece

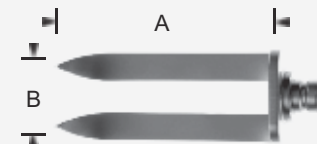

Blade	A	B
Fig. 3		
13-941-32	32 x 52 mm	1 piece
13-941-37	37 x 52 mm	1 piece
13-941-42	42 x 52 mm	1 piece
13-941-47	32 x 52 mm	1 piece
13-941-52	52 x 52 mm	1 piece
13-941-57	57 x 52 mm	1 piece
13-941-65	65 x 52 mm	1 piece
13-941-67	67 x 52 mm	1 piece

Laminectomy Retractors  
 Laminektomie-Retraktoren  
 Retradores de laminectomía  
 Écarteurs de laminectomie  
 Divaricatori per laminectomia

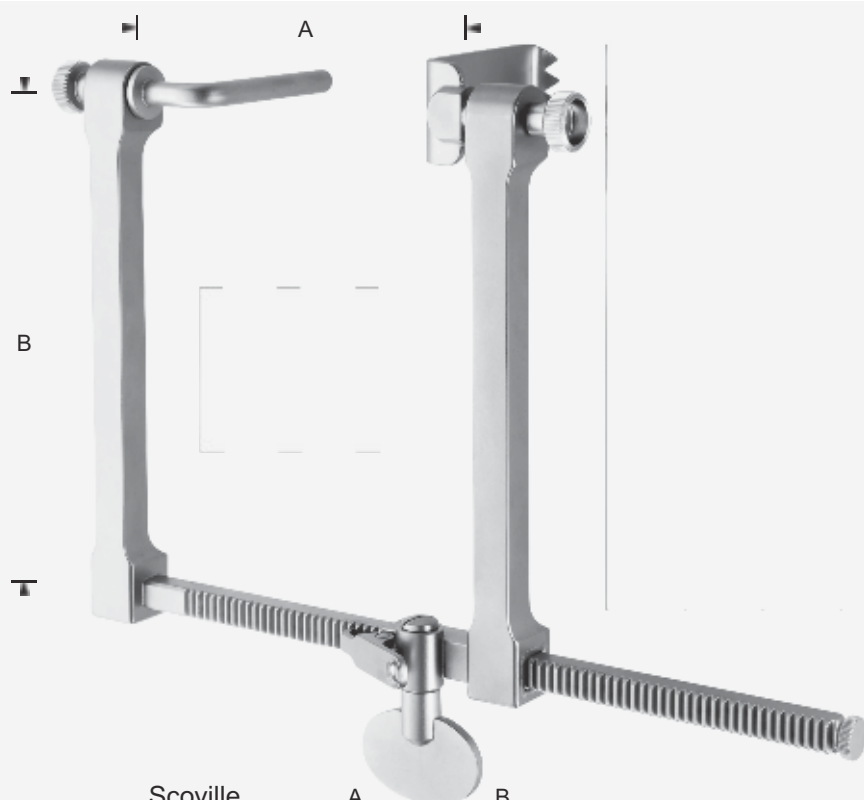

Scoville	A	B	
13-942-01	22 cm - 8 3/4"	14 cm - 5 1/2"	Retractor only
13-942-00	Complete set consisting of:		
13-942-01	1 Retractor		
	1 pair of each, 13-945-47 to 13-945-60		



Fig. 1

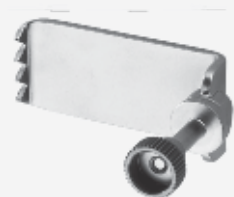
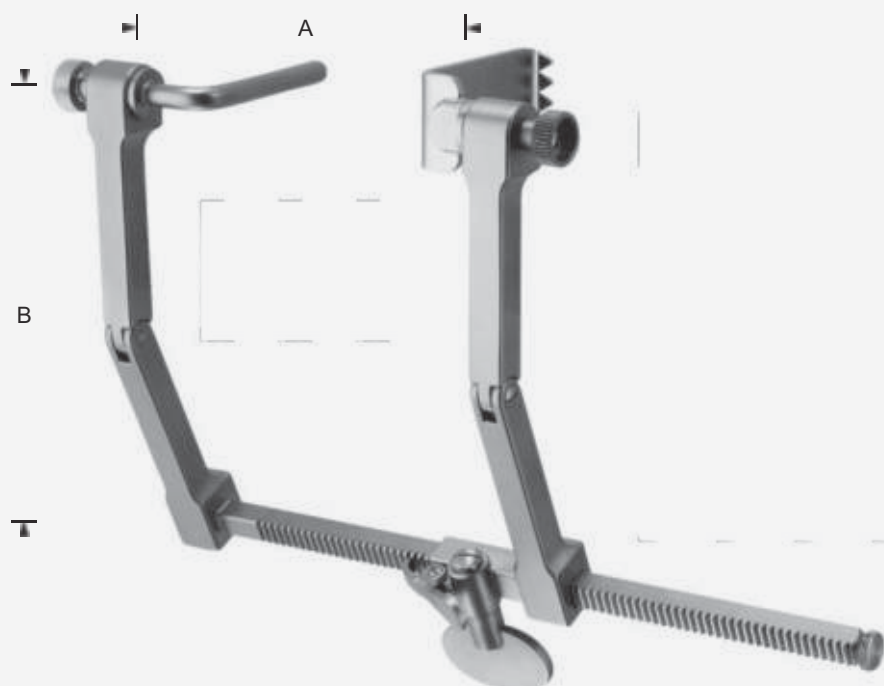

Fig. 2

Scoville		
13-945-57	Fig. 1	57 mm
13-945-60	Fig. 2	60 x 25 mm
	1 pair of blades only	



Scoville - Haverfield	A	B	
13-943-01	22 cm - 8 3/4"	14 cm - 5 1/2"	Retractor only
13-943-00	Complete set consisting of:		
13-943-01	1 Retractor		
	1 pair of each, 13-945-57 to 13-945-60		



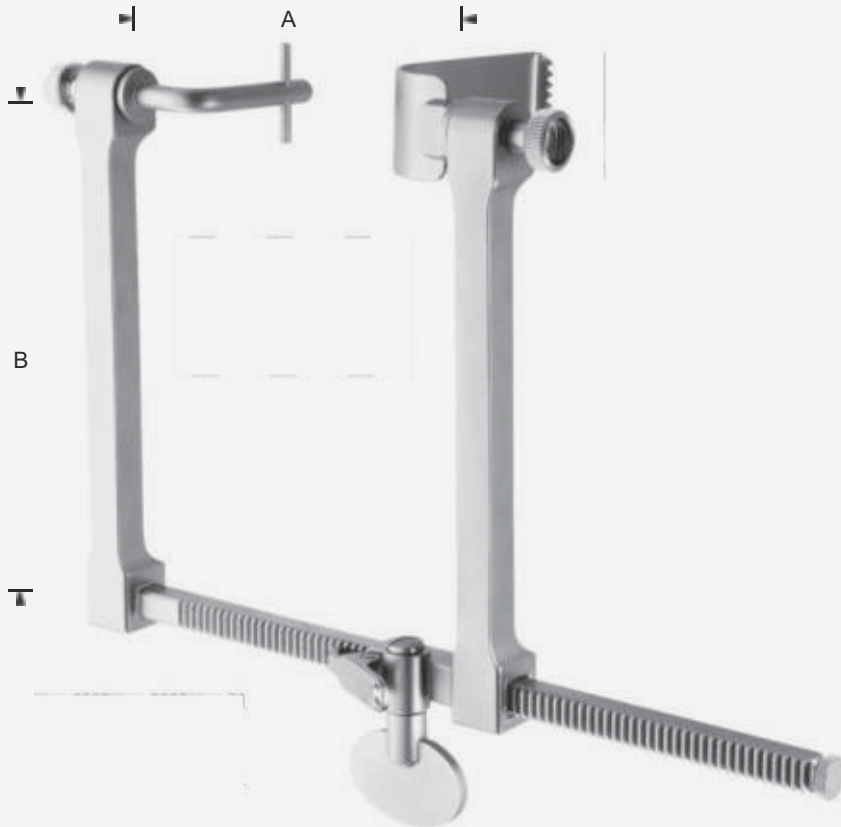

Scoville	A	B	
13-944-01	22 cm - 8 3/4"	14 cm - 5 1/2"	Retractor only
13-944-00	Complete set consisting of:		
13-944-01	1 Retractor		
	1 pair of each, 13-947-48 to 13-947-78		



Scoville	
13-947-48	48 mm
13-947-58	58 mm
13-947-78	78 mm



Meyerding	
13-956-48	48 x 25 mm
13-956-81	81 x 25 mm
13-956-90	90 x 50 mm



**Scoville**

13-945-57	57 mm
13-945-83	83 mm

Blunt, wide

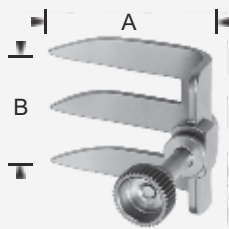

**Taylor /  
Scoville**

	A	B
13-948-45	45	39 mm
13-948-50	50	35 mm

3 prongs



**Scoville**

13-946-57	57 mm
13-946-71	71 mm

Sharp

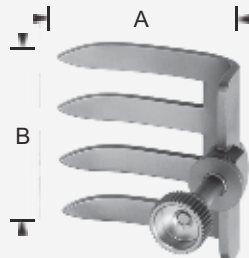

**Taylor /  
Scoville**

	A	B
13-949-70	70	46 mm
13-949-50	50	50 mm
13-949-62	62	57 mm
13-949-80	80	57 mm

4 prongs



**Scoville**

13-947-48	48 mm
13-947-58	58 mm
13-947-78	78 mm

With crossbar

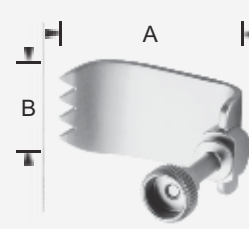

**Hibbs**

	A	B
13-950-48	48	19 mm
13-950-58	58	51 mm
13-950-51	51	26 mm
13-950-60	60	38 mm
13-950-65	65	26 mm
13-950-74	74	38 mm
13-951-74	74	64 mm
13-951-78	78	50 mm
13-951-80	80	26 mm
13-951-89	89	26 mm
13-951-90	92	39 mm
13-951-10	104	51 mm
13-952-10	105	26 mm

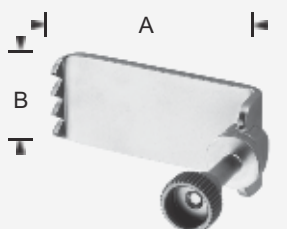

**Scoville**

	A	B
13-953-60	60	25 mm
13-953-78	78	51 mm
13-954-78	78	29 mm
13-954-91	91	26 mm

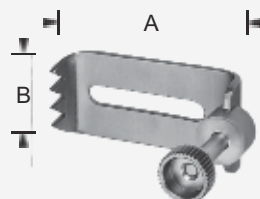

**Epstein**

	A	B
13-955-70	57	26 mm

Fenestrated

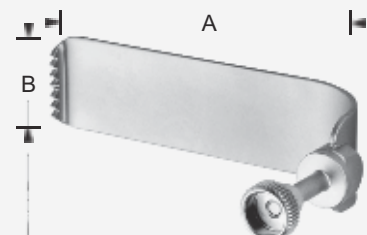

**Meyerding**

	A	B
13-956-48	48	25 mm
13-956-62	62	25 mm
13-956-70	70	25 mm
13-956-78	78	25 mm
13-956-81	81	25 mm
13-956-90	90	50 mm

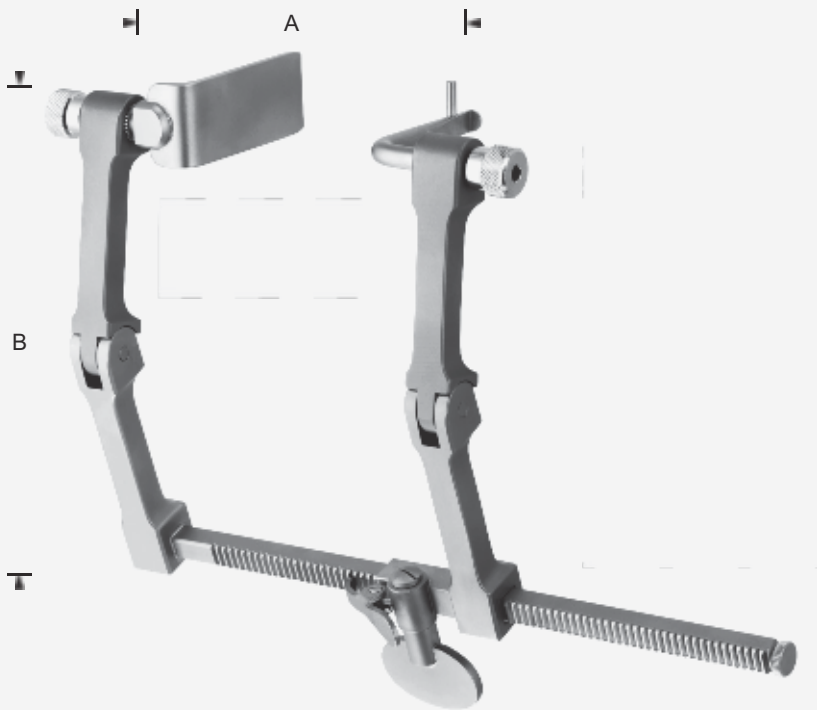

Scoville	A	B	
13-957-01	22 cm - 8 3/4"	14 cm - 5 1/2"	Retractor only
13-957-00	Complete set consisting of:		
13-957-01	1 Retractor		
13-959-60	1 blade		
13-959-58	1 blade		

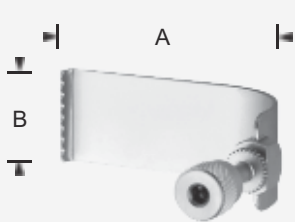

Meyerding	A	B
13-958-48	48 x 25 mm	
13-958-62	62 x 25 mm	
13-958-70	70 x 25 mm	
13-958-78	78 x 25 mm	
13-958-81	81 x 25 mm	
13-958-90	90 x 50 mm	

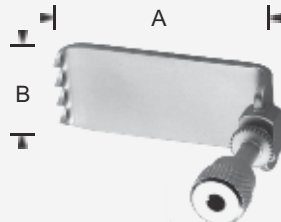

Scoville	A	B
13-959-60	60 x 25 mm	
13-959-78	78 x 29 mm	
13-959-78	78 x 51 mm	
13-959-91	91 x 26 mm	

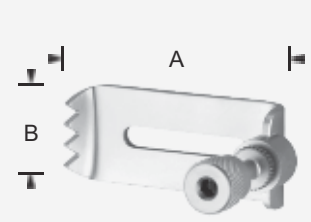

Epstein	A	B
13-960-48	48 x 26 mm	

Fenestrated

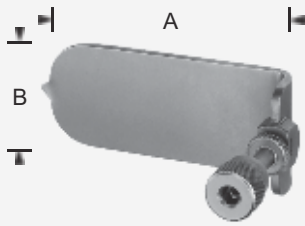

Taylor		A	B
13-961-80		80 x 31 mm	
13-961-10		105 x 42 mm	



Taylor		
13-962-60		60 mm
13-962-70		70 mm



Scoville		
13-963-57		57 mm
13-963-77		77 mm

Pointed



Scoville		
13-964-57		57 mm
13-964-83		83 mm

3 prongs



Scoville		
13-965-48		48 mm
13-965-58		58 mm
13-965-78		78 mm

With crossbar

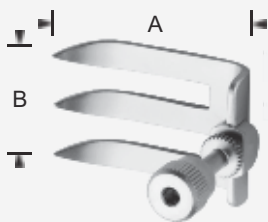

Scoville		A	B
13-966-50		50 x 35 mm	
13-966-45		45 x 39 mm	

3 prongs

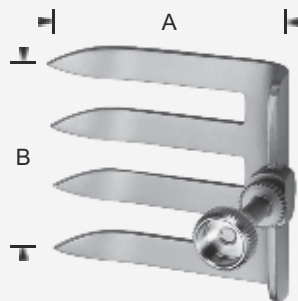

Scoville		A	B
13-967-50		50 x 50 mm	
13-967-62		62 x 57 mm	
13-967-70		70 x 46 mm	
13-967-80		80 x 57 mm	

4 prongs

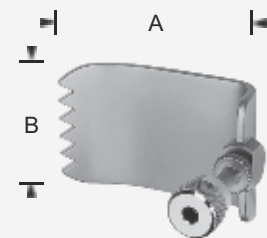

Hibbs		A	B
13-968-48		48 x 19 mm	
13-968-58		58 x 51 mm	
13-968-51		51 x 26 mm	
13-968-60		60 x 38 mm	
13-968-65		65 x 26 mm	
13-968-74		74 x 38 mm	
13-969-74		74 x 64 mm	
13-969-78		78 x 50 mm	
13-969-80		80 x 26 mm	
13-969-89		89 x 26 mm	
13-969-90		92 x 39 mm	
13-969-10		104 x 51 mm	
13-970-10		105 x 26 mm	



Thorax – Lung  
Thorax – Lunge  
Tórax – Pulmón  
Thorax – Poumon  
Torace – Polmone



Lebsche

14-904-24 24.5 cm - 9 ¾"



Brunner

14-905-01

for the right hand  
 für die rechte Hand  
 para la manoderecha  
 pour la main droite  
 per la mano destra



14-905-02

for the left hand  
 für die linke Hand  
 para la mano izquierda  
 pour la main gauche  
 per la mano sinistra

32 cm - 12 ½"



Sauerbruch-Frey

14-906-36

36 cm - 14 ¼"



Sauerbruch

14-907-26 26 cm - 10 ¼"



Giertz-Stille

14-908-27 27 cm - 10 ¾"



Bethune

14-909-34 34 cm - 13 ½"

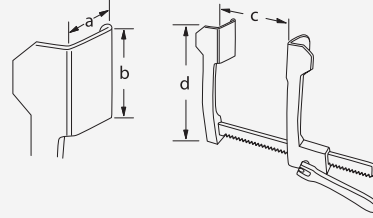

**Burford 8"**

14-910-08

Aluminium

a	b	c	d
45 mm	62 mm	165 mm	200 mm
65 mm	62 mm		

for adults, with 2 pairs of interchangeable blades

**Burford 10"**

14-911-10

Aluminium

a	b	c	d
45 mm	62 mm	250mm	200 mm
65 mm	62 mm		

for adults, with 2 pairs of interchangeable blades

**Burford 12"**

14-912-12

Aluminium

a	b	c	d
45 mm	62 mm	290 mm	200 mm
65 mm	62 mm		

for adults, with 2 pairs of interchangeable blades

**Burford**

14-913-00

Aluminium

a	b	c	d
30 mm	42 mm	130 mm	117 mm
41 mm	42 mm		

for adults, with 2 pairs of interchangeable blades

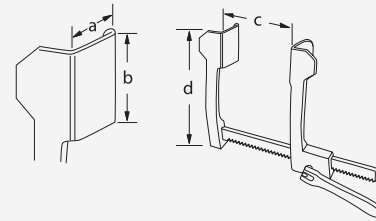

**Finochietto**

14-914-00

Aluminium

a	b	c	d
40 mm	45 mm	165 mm	110 mm

small size, for children

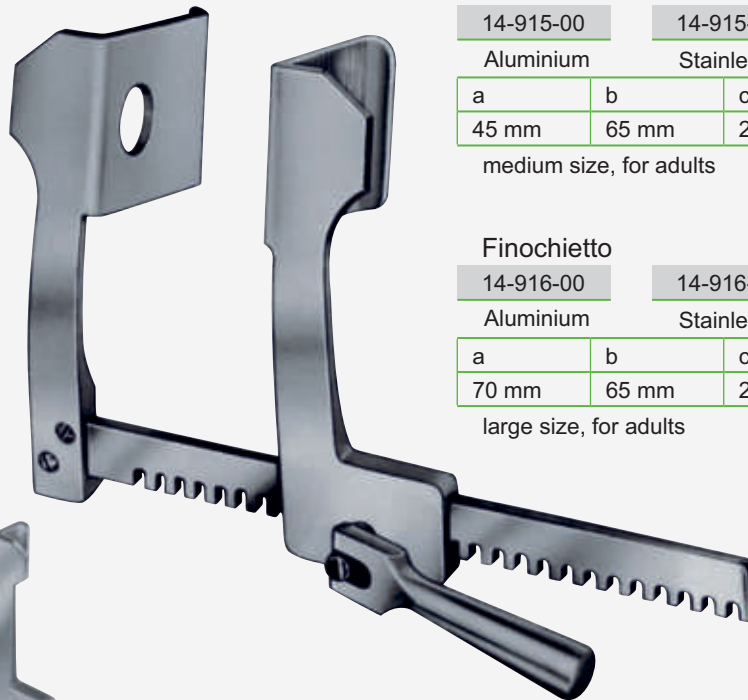

**Finochietto**

14-915-00

Aluminium

14-915-01

Stainless steel

a	b	c	d
45 mm	65 mm	200mm	140 mm

medium size, for adults

**Finochietto**

14-916-00

Aluminium

14-916-01

Stainless steel

a	b	c	d
70 mm	65 mm	250 mm	140 mm

large size, for adults

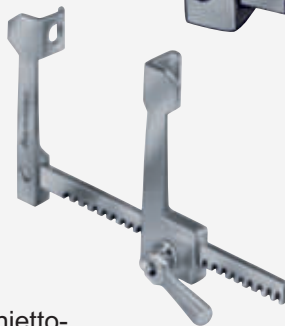

**Finochietto-  
 Baby-Haight**

14-917-00

Aluminium

14-917-01

Stainless steel

a	b	c	d
27 mm	30 mm	95 mm	80 mm

for children

**Finochietto-  
 Infant**

14-918-00

Aluminium

14-918-01

Stainless steel

a	b	c	d
12 mm	15 mm	70 mm	55 mm

for infants



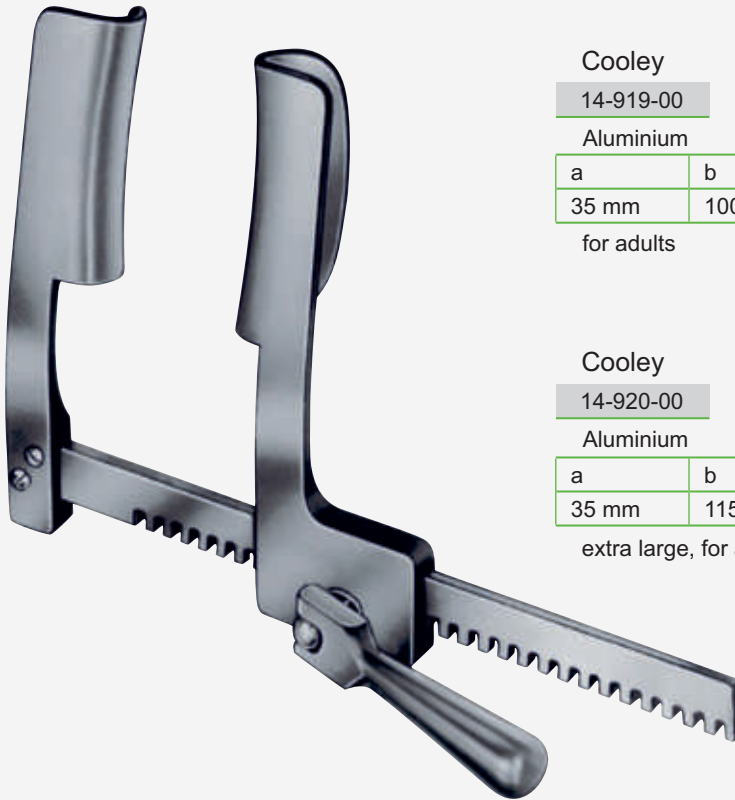
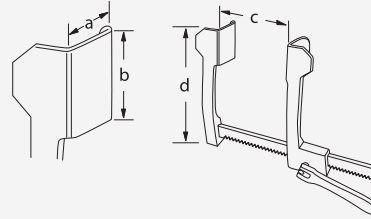

Cooley

14-919-00

Aluminium

a	b	c	d
35 mm	100 mm	180 mm	180 mm

for adults

Cooley

14-920-00

Aluminium

a	b	c	d
35 mm	115 mm	230 mm	205 mm

extra large, for adults

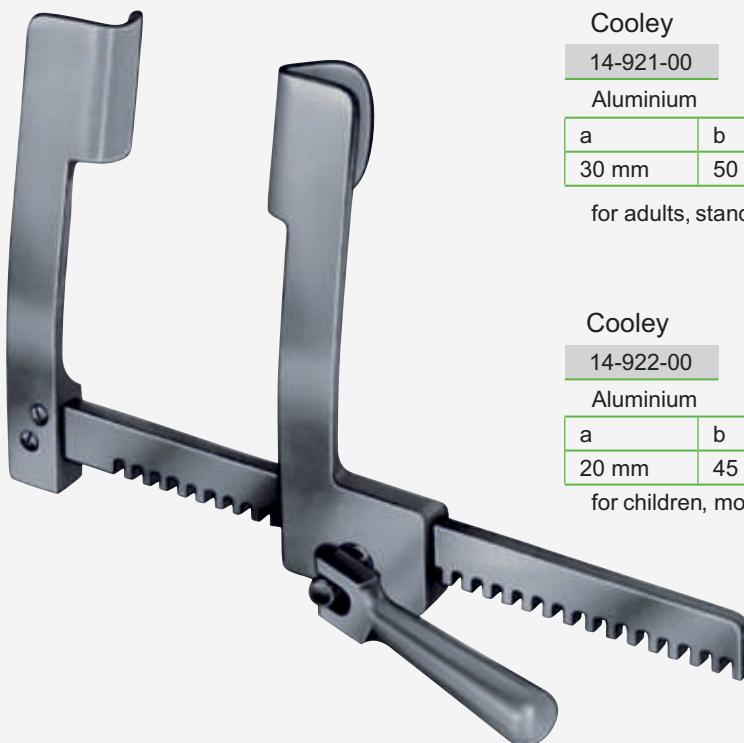

Cooley

14-921-00

Aluminium

a	b	c	d
30 mm	50 mm	185 mm	145 mm

for adults, standard size, modified

Cooley

14-922-00

Aluminium

a	b	c	d
20 mm	45 mm	140 mm	110 mm

for children, modified

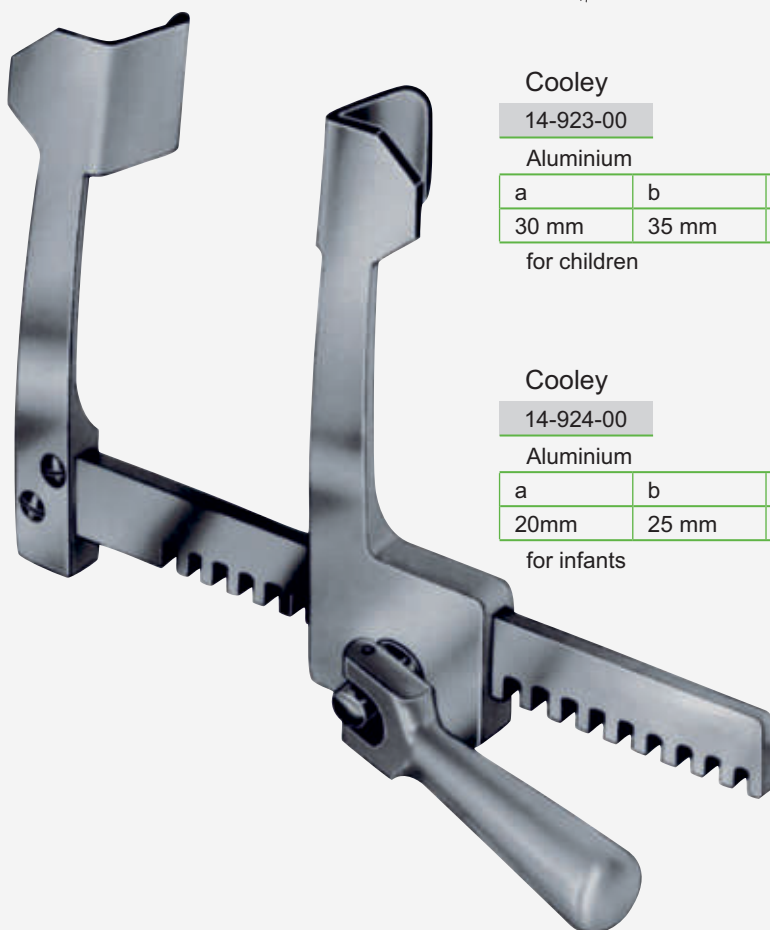
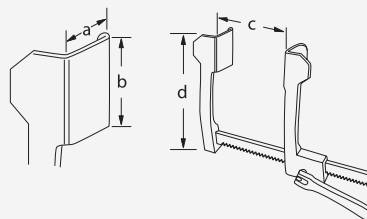

**Cooley**

14-923-00

Aluminium

a	b	c	d
30 mm	35 mm	140 mm	110 mm

for children

**Cooley**

14-924-00

Aluminium

a	b	c	d
20mm	25 mm	100 mm	80 mm

for infants



**Cooley**

14-925-00

Aluminium

a	b	c	d
12mm	15 mm	70 mm	55 mm

for infants

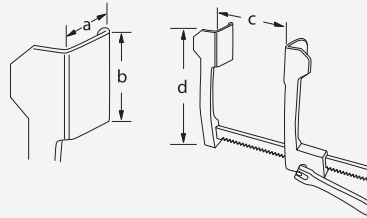

**Cooley**

14-926-00

Aluminium

a	b	c	d
15 mm	30 mm	115 mm	80 mm

for children, sternal spreader, light-wieght but sturdy

**Cooley**

14-927-00

Aluminium

a	b	c	d
14 mm	16 mm	85 mm	55 mm

for newborns

**Cooley**

14-928-00

Aluminium

a	b	c	d
15 mm	20 mm	100 mm	80 mm

for infants, sternal spreader with prongs

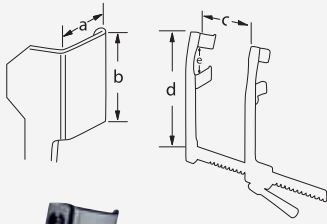

### Morse Sternal

14-929-00

Aluminium

a	b	c	d	e
20 mm	20 mm	155 mm	120 mm	50 mm

with 2 pairs of movable blades, for children, arms curved between blades

### Morse-Favaloro Sternal

14-930-00

Aluminium

a	b	c	d	e
40 mm	20 mm	155 mm	175 mm	65 mm

with 2 pairs of movable blades, for adults, arms curved between blades

### Morse-Favaloro Sternal

14-931-00

Aluminium

a	b	c	d	e
12 mm	20 mm	155 mm	120 mm	50 mm

with 2 pairs of movable blades, for children, arms curved between blades

### Morse Sternal

14-932-00

Aluminium

a	b	c	d	e
20 mm	28 mm	210 mm	155 mm	72 mm

with 2 pairs of movable blades, for adults, arms curved between rack and blades

### Morse Sternal

14-933-00

Aluminium

a	b	c	d	e
20 mm	20 mm	155 mm	120 mm	50 mm

with 2 pairs of movable blades, for children, arms curved between rack and blades

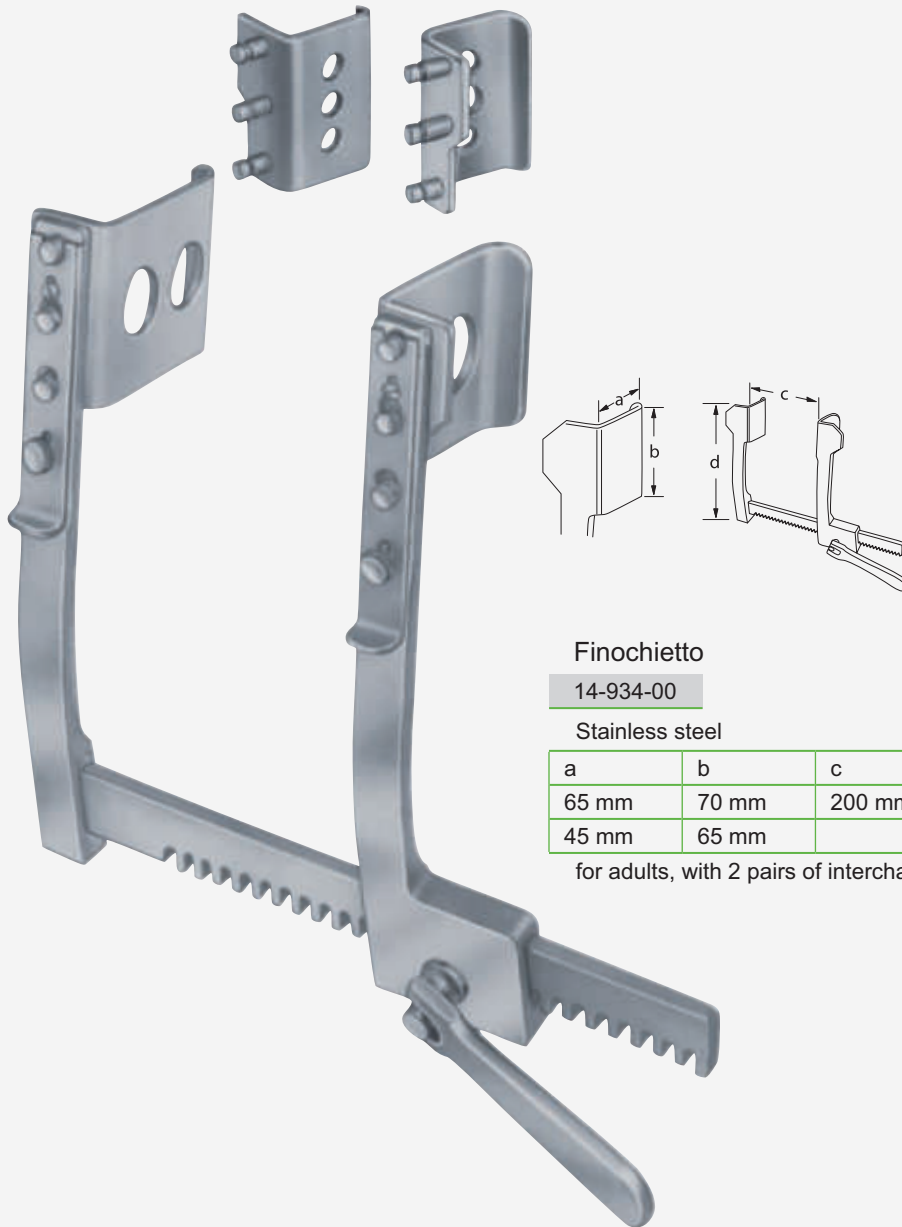

**Finochietto**

14-934-00

Stainless steel

a	b	c	d
65 mm	70 mm	200 mm	140 mm
45 mm	65 mm		

for adults, with 2 pairs of interchangeable blades



**Baby-Haight**

14-935-00

14-935-01

Stainless steel

a	b	c	d
28 mm	30 mm	85 mm	70 mm
28 mm	30 mm	100 mm	75 mm

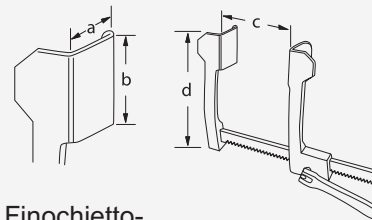
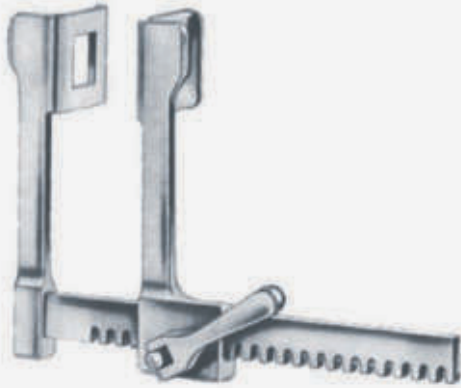

Finochietto-Baby

14-936-00

Stainless steel

a	b	c	d
14 mm	15 mm	75 mm	55 mm



Finochietto

14-937-00

14-937-01

14-937-02

Stainless steel

a	b	c	d
40 mm	40 mm	165 mm	110 mm
45 mm	65 mm	200 mm	140 mm
70 mm	65 mm	250 mm	140 mm

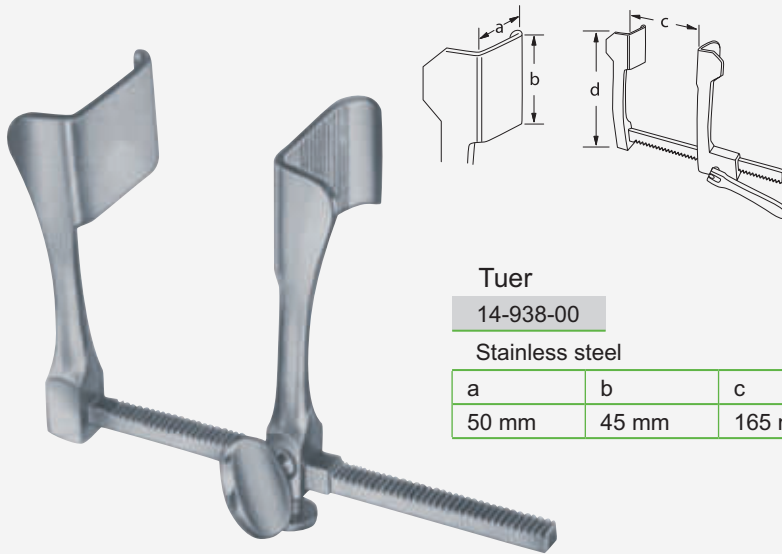

**Tuer**

14-938-00

Stainless steel

a	b	c	d
50 mm	45 mm	165 mm	110 mm

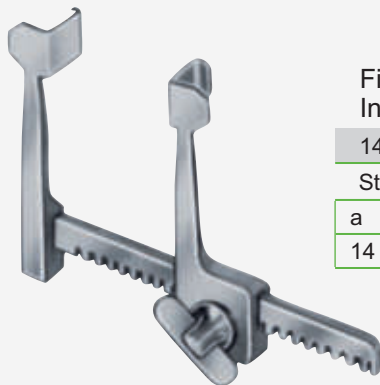

**Finochietto-  
Infant**

14-939-00

Stainless steel

a	b	c	d
14 mm	15 mm	55 mm	25 mm

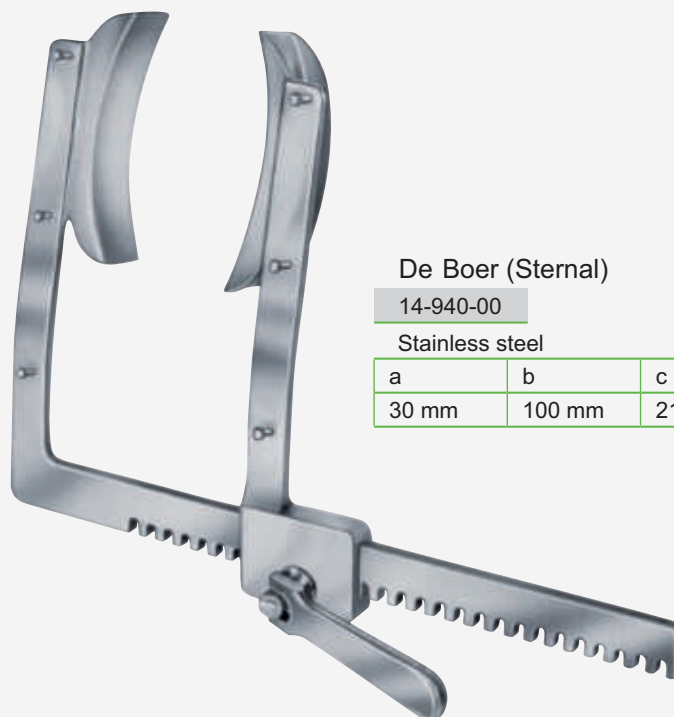

**De Boer (Sternal)**

14-940-00

Stainless steel

a	b	c	d
30 mm	100 mm	210 mm	185 mm

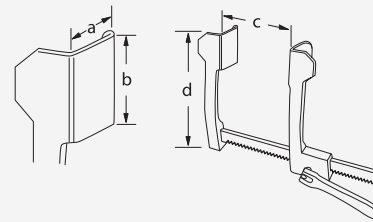

**De Bakey**

14-941-00

Stainless steel

a	b	c	d
20 mm	30 mm	120 mm	130 mm
30 mm	30 mm		

for children, with 2 pairs of interchangeable blades

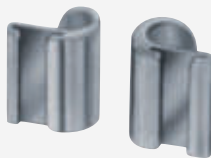

**De Bakey**

14-942-00

Stainless steel

a	b	c	d
30 mm	60 mm	200 mm	190 mm
48 mm	60 mm		

for adults, with 2 pairs of interchangeable blades

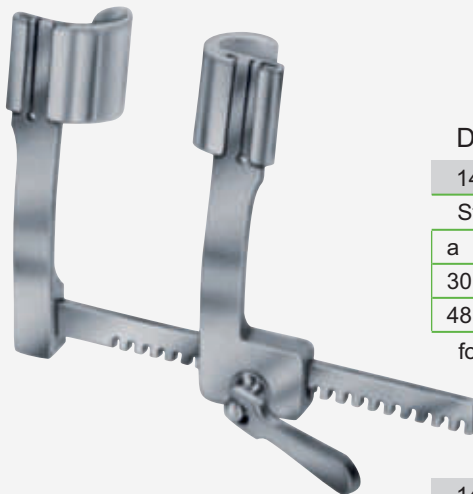

14-943-00

14-943-01

14-943-02

a	b
30 mm	30 mm
30 mm	60 mm
48 mm	60 mm

pair of blades



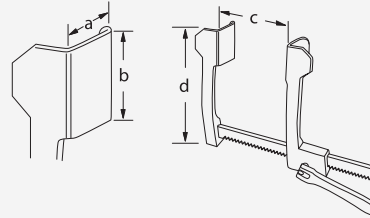

**Mercedes  
Thoraxsperrer**

14-944-00

Stainless steel

a	b	c	d
45 mm	68 mm	285 mm	185 mm
70 mm	75 mm		

for adults, with 2 pairs of interchangeable blades with ball snap system

14-945-01

14-945-02

Stainless steel  
pair of blades

a	b
45 mm	68 mm
70 mm	75 mm

Thoracic and I.M.A. retractor  
I.M.A. Thoraxsperrer  
Separador torácico e I.M.A.  
Ecarteur thoracique et I.M.A.  
Toracica e I.M.A. divaricatore

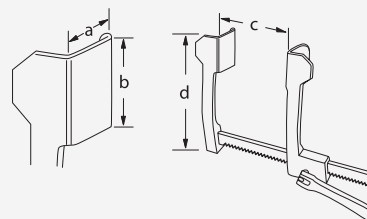

**Mammaria-  
Spreizer**

14-946-00

Stainless steel

a	b	c	d
55 mm	100 mm	170 mm	130 mm

with detachable tilting IMA blade and set-screw to lift the sternal margin for the dissection of the IMA

Lung spatula – Rib contractors  
 Lungenspatel – Rippenkontraktoren  
 Espátulapulmonar - Aproximadores para constillas  
 Spatules pulmonaires - Rapprocheurs  
 Lung spatola - appaltatori Rib



Allison

14-947-30 30 cm - 12"

14-947-32 32 cm - 12 ½"



Bailey-Baby

14-948-14 14 cm - 5 ½"



Bailey

14-949-16 16 cm - 6 ¼"



Lemmon  
14-950-14 14.5 cm - 5 ¾"  
14-950-18 18 cm - 7"



Bailey-Gibbon  
14-951-16 16 cm - 6 ¼"

Rib contractors  
Rippenkontraktoren  
Aproximadores para costillas  
Rapprocheurs  
appaltatori Rib

comed  
operate better with us



Sellors

14-952-19 19 cm - 7 ½"



Stomach – Intestine  
Magen – Darm  
Estómago – Intestino  
Estomac – Intestin  
Stomaco – Intestino

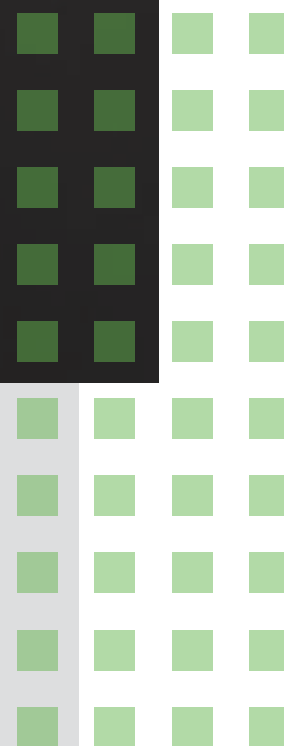



Allis-Baby

15-200-13 13 cm - 5"

4 x 5

Teeth

Zähne

Dientes

Dents

Denti



Allis

15-201-15 15-202-15 15 cm - 6"

15-201-19 15-202-19 19 cm - 7 ½"

15-201-25 15-202-25 25 cm - 9 ¾"

4 x 5

5 x 6

Teeth

Zähne

Dientes

Dents

Denti



Allis-Adair

15-203-15 15.5 cm - 6"

10 x 11

Teeth

Zähne

Dientes

Dents

Denti



Thomas-Allis

15-204-20 20 cm - 8"

7 x 6

Teeth

Zähne

Dientes

Dents

Denti



Lockwood

15-205-20 20 cm - 8"



Williams

15-206-16 16 cm - 6 ¼"



Littlewood

15-207-19 19 cm - 7 1/2"

2 x 3  
Teeth  
Zähne  
Dientes  
Dents  
Denti



Boys-Allis

15-208-15 15 cm - 6"

5 x 6  
Teeth  
Zähne  
Dientes  
Dents  
Denti



Judd-Allis

15-209-15 15 cm - 6"

15-209-19 19 cm - 7 1/2"

3 x 4  
Teeth  
Zähne  
Dientes  
Dents  
Denti



Babcock

15-210-16 16 cm - 6 1/4"

15-211-20 20 cm - 8"

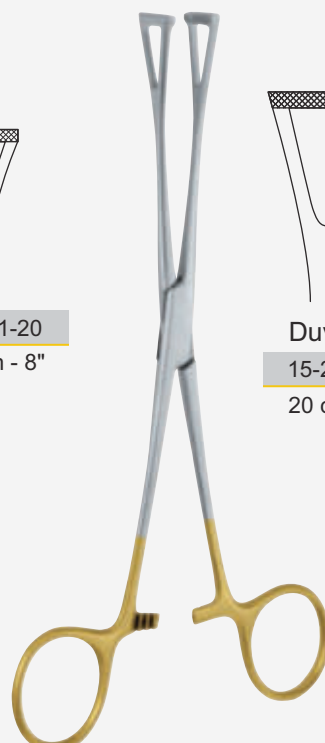

Duval

15-212-20 20 cm - 8"



Babcock

15-213-16 16 cm - 6 1/4"

15-213-18 18 cm - 7"

15-213-20 20 cm - 8"

15-213-24 24 cm - 9 1/2"





Duval

15-214-18	15-215-18	18 cm - 7"
15-214-20	15-215-20	20 cm - 8"
15-214-23	15-215-23	23 cm - 9"



Babcock-  
Atrauma

15-216-16	15-217-20
16 cm - 6 1/4"	20 cm - 8"

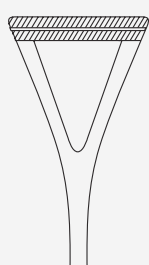

Duval-  
Atrauma

15-218-23
23 cm - 9"

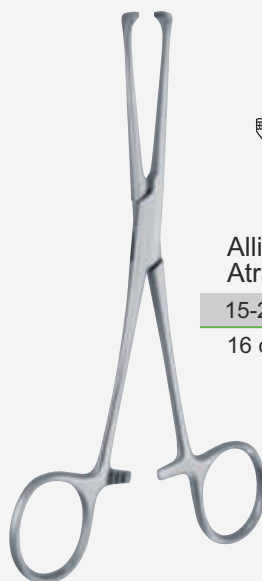

Allis-  
Atrauma

15-220-16	15-221-20	15-222-25
16 cm - 6 1/4"	20 cm - 8"	25 cm - 9 3/4"



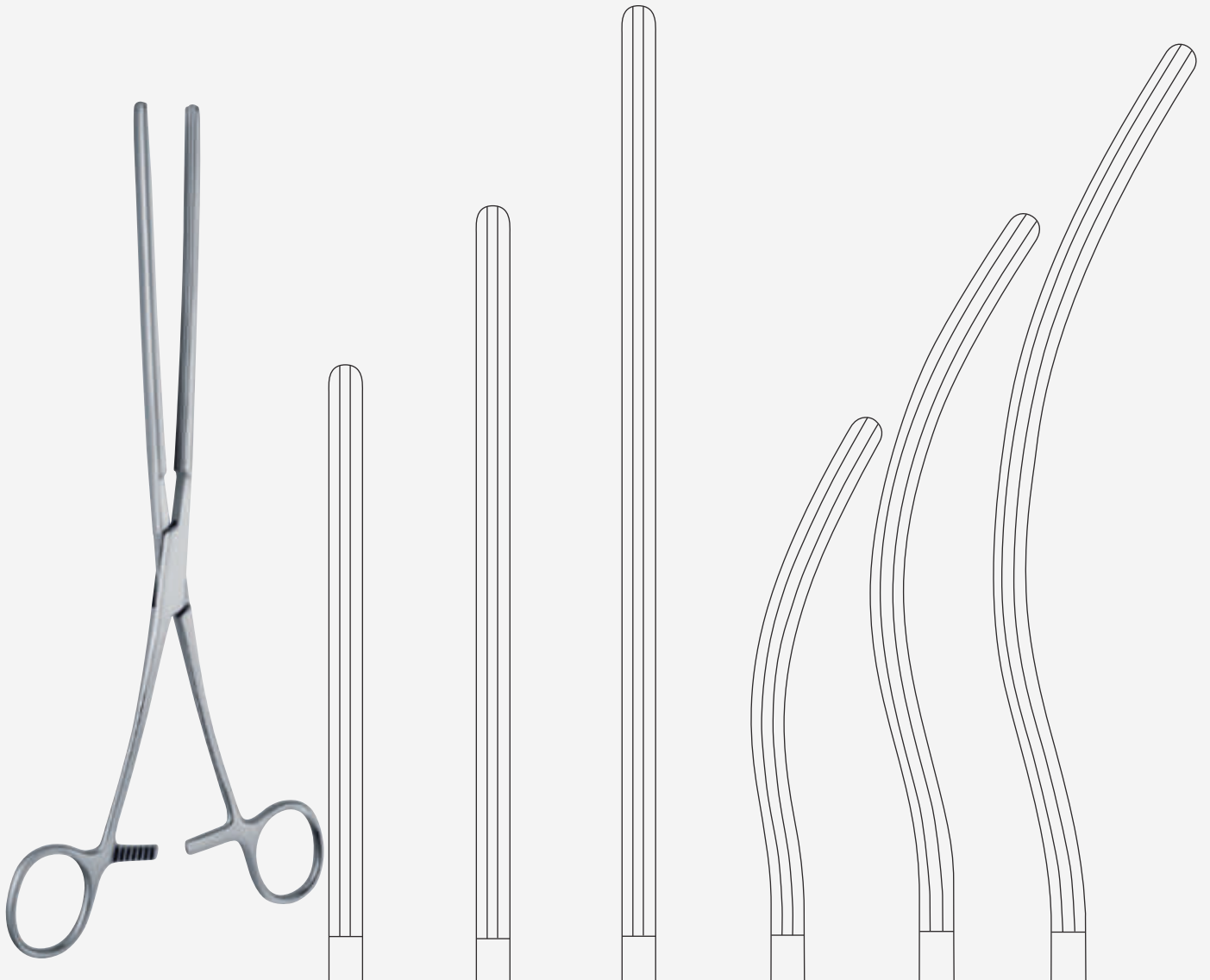

**Kocher**

<b>15-223-22</b>	<b>15-224-25</b>	<b>15-225-28</b>	<b>15-226-22</b>	<b>15-227-25</b>	<b>15-228-28</b>
22 cm - 8 3/4"	25 cm - 9 3/4"	28 cm - 11"	22 cm - 8 3/4"	25 cm - 9 3/4"	28 cm - 11"

Intestinal and stomach clamps  
 Darm- und Magenklammern  
 Pinzas-clamps para el intestino y el estomago  
 Pincas-clampspour l'intestin et l'estomac  
 Morsetti intestinali e di stomaco



Allen

15-229-15 15 cm - 6"

1 x 2

Intestinal clamp for children  
 Darmklemme für Kinder  
 Pinza intestinal para niños  
 Pince intestinal pour enfants  
 Pinza intestinale per bambini



Baby-Kocher

15-230-13

15-231-13

13 cm - 5"

Intestinal clamp for children, very elastic blades  
 Darmklemme für Kinder, sehr elastisch  
 Pinza intestinal para niños, muy elastica  
 Pince intestinal pour enfants, très élastique  
 Pinza intestinale per bambini, molto elastica

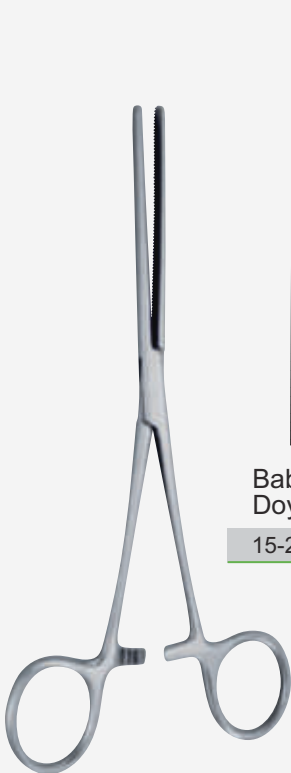

Baby-Doyen

15-232-18

15-233-18

18 cm - 7"



Doyen

15-234-21

15-235-21

21 cm - 8 1/4"

15-234-23

15-235-23

23 cm - 9"

15-234-28

15-235-28

28 cm - 11"

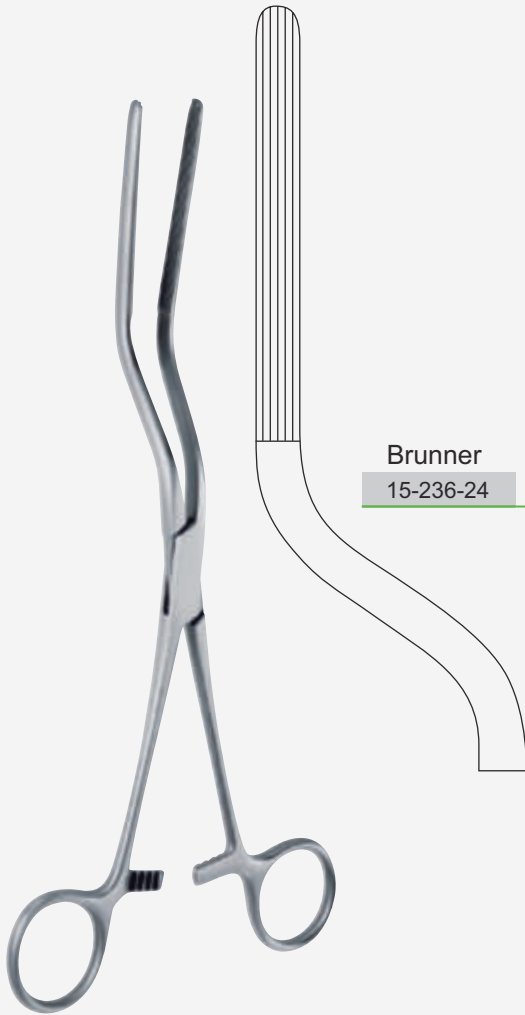

**Brunner**  
15-236-24 24 cm - 9 1/2"



**Mayo-  
Robson**  
15-237-25

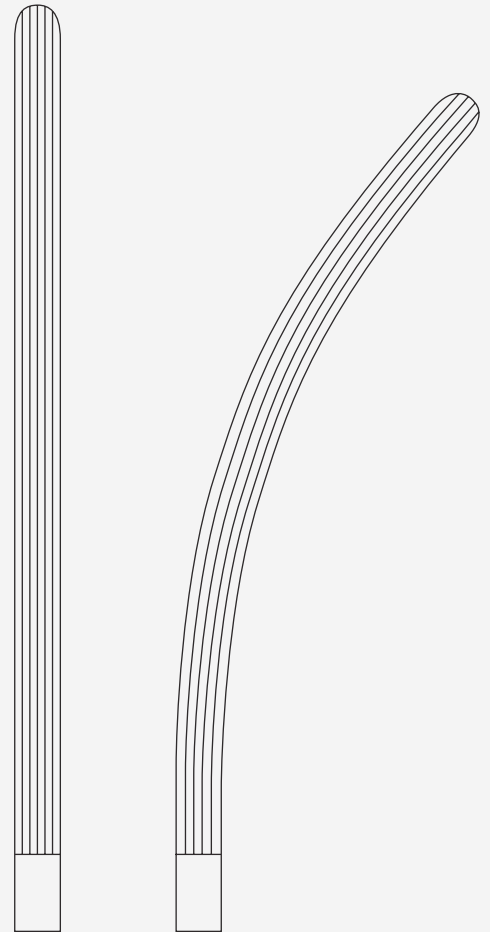

15-238-25 25 cm - 9 1/2"

Intestinal and stomach clamps  
Darm- und Magenklappen  
Pinzas-clamps para el intestino y el estomago  
Pincas-clampspour l'intestin et l'estomac  
Morsetti intestinali e di stomaco

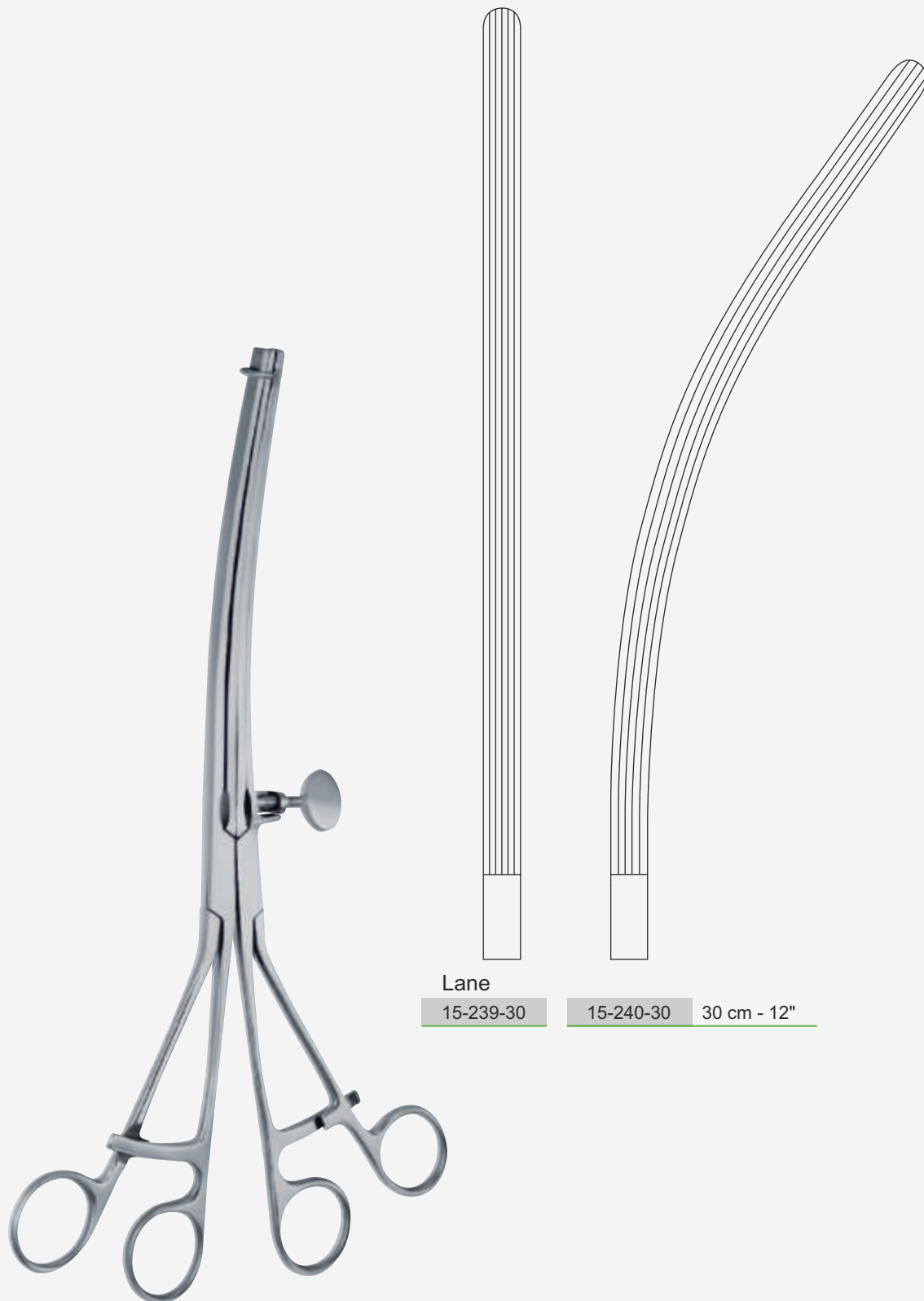

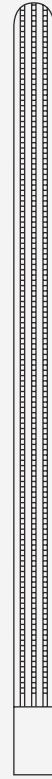

Doyen

15-241-14

14 cm - 5 1/2"

15-242-16

16 cm - 6 1/4"

15-243-18

18 cm - 7"

15-244-21

21 cm - 8 1/4"

15-245-23

23 cm - 9"

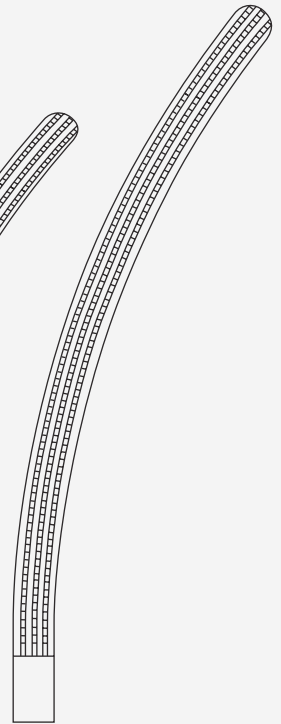
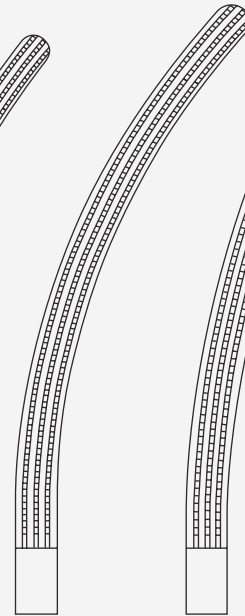
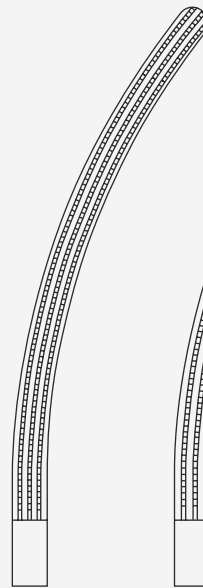
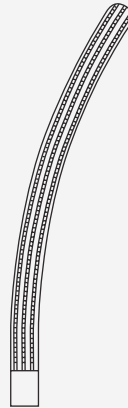
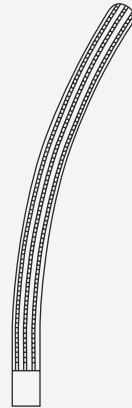

Doyen

15-246-14

14 cm - 5 1/2"

15-247-16

16 cm - 6 1/4"

15-248-18

18 cm - 7"

15-249-21

21 cm - 8 1/4"

15-250-23

23 cm - 9"

Atraumatic intestinal clamp forceps  
Atraumatische Darmklemmen  
Pinzas-clamps atraumáticas intestinales  
Pinces-clamps atraumatiques pour l'intestin  
Atraumatiche pinza clamp intestinale

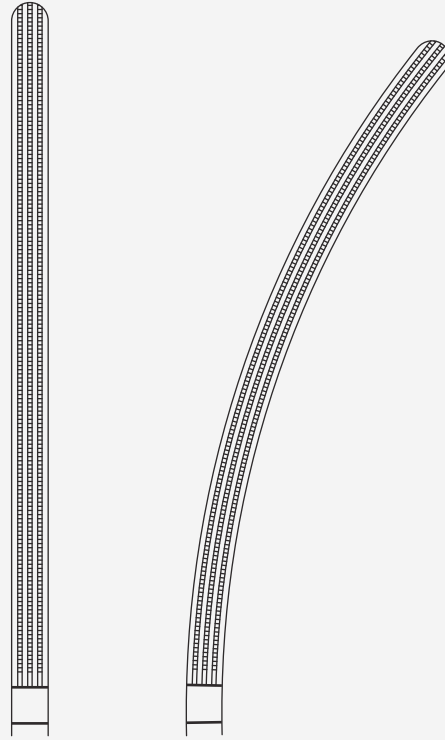

Mayo-Robson

15-251-25

15-252-25

25 cm - 9 3/4"



Resano

15-259-30

30 cm - 12"

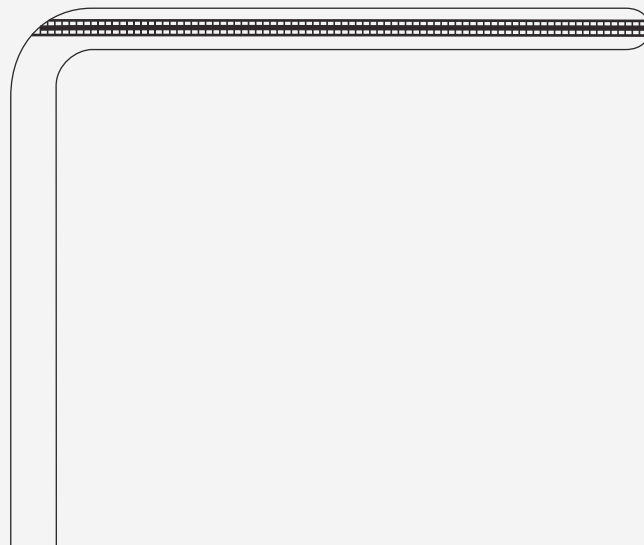

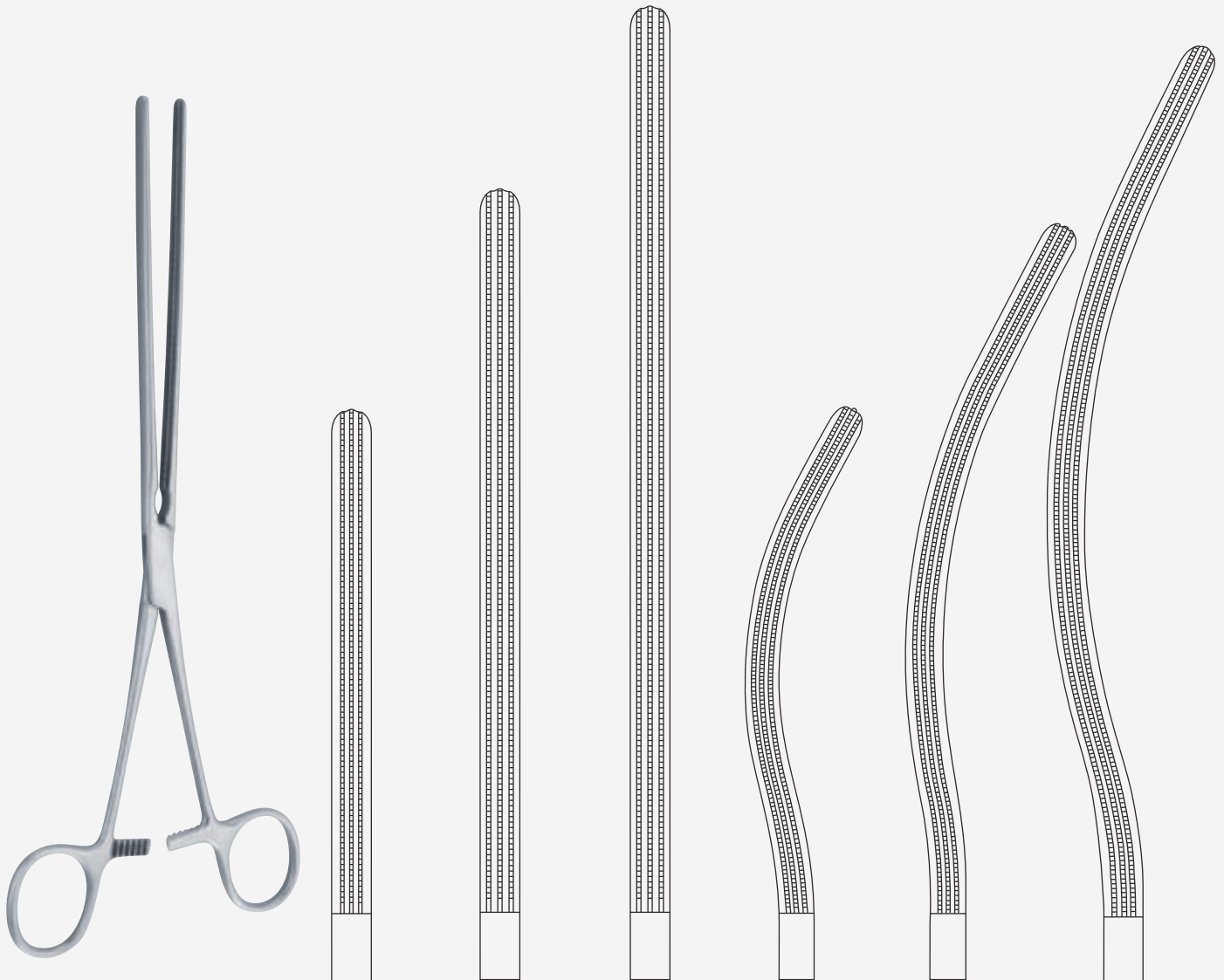

Kocher

15-253-22

22 cm - 8 3/4"

15-254-25

25 cm - 9 3/4"

15-255-28

28 cm - 11"

15-256-22

22 cm - 8 3/4"

15-257-25

25 cm - 9 3/4"

15-258-28

28 cm - 11"

Sigmoid anastomosis forceps  
Rektum-Anastomosenklemmen  
Pinzas para anastomosis rectales  
Pincespour anastomoses rectales  
Pinze anastomosi sigma



Hayes

15-260-26

26 cm - 10 1/4"

15-261-28

28 cm - 11"

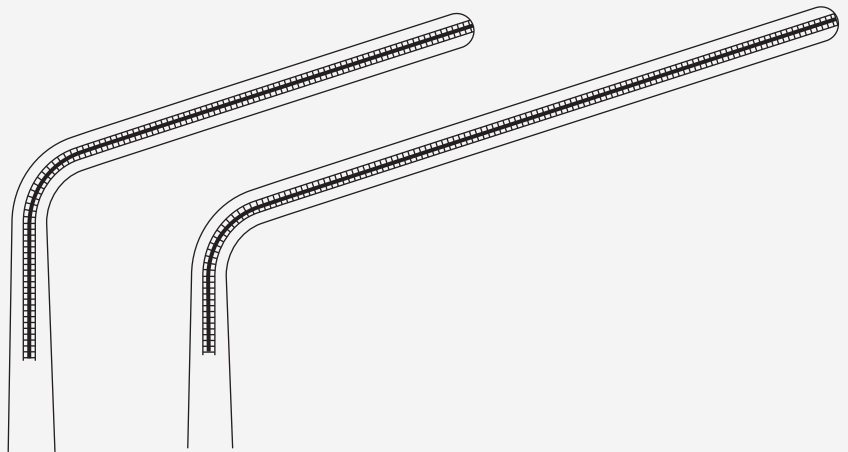

Fehland

15-262-24

24 cm - 10 1/2"

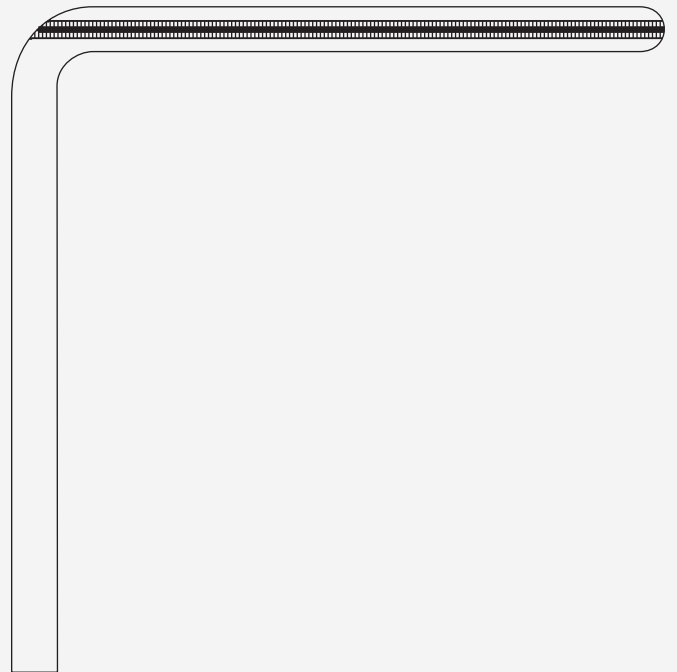



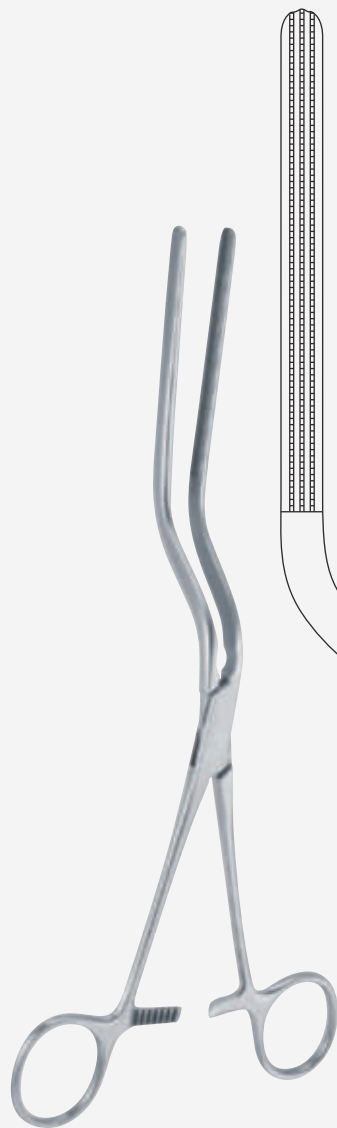

Brunner

15-263-24 24 cm - 9 ½"

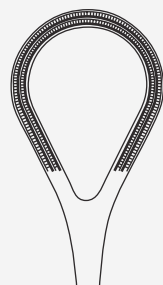

**Maxter**  
 Fig. 1

15-264-25 25 cm - 9 3/4"

Organfasszange mittel, 250 mm  
 Organ grasping forceps medium, 250 mm  
 Pince medium pour saisir des organes, 250 mm  
 Pinzamediano para sacar órganos, 250 mm  
 Pinze per aerrare organi, 250 mm

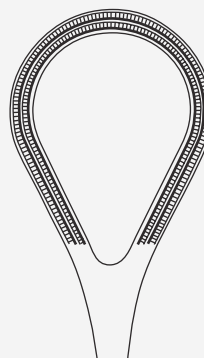
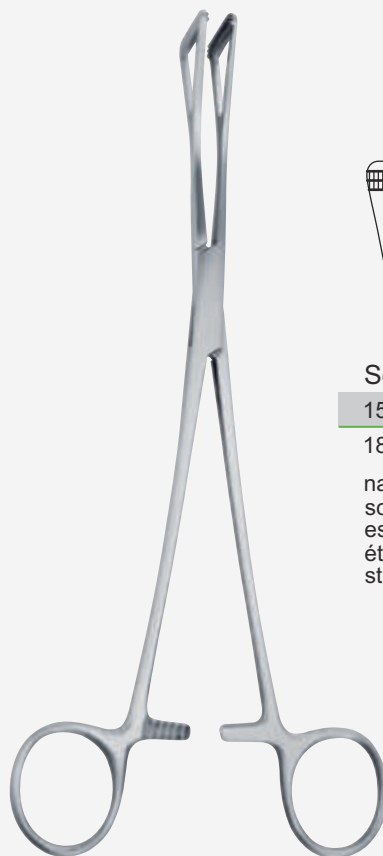

Fig. 2

15-265-26 26 cm - 10 1/4"

Organ grasping forceps large, 260 mm  
 Organfasszange gross, 260 mm  
 Pinza grande para sacar órganos, 260 mm  
 Pince grande pour saisir des organes, 260 mm  
 Pinze per aerrare organi, 260 mm



**Scheibe**

15-266-18

18 cm - 7"

narrow  
 schmal  
 estrecho  
 étroit  
 stretto



15-267-20

20 cm - 8"

medium  
 mittel  
 mediano  
 moyen  
 medio

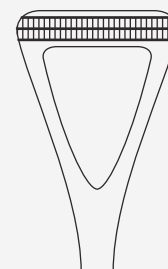

15-268-23

23 cm - 9"

wide  
 breit  
 ancho  
 large  
 largo



**Payr-Baby**

15-269-15 15 cm - 6"

with pin  
mit Stift  
con pivote  
avec cheville  
con perno



**Payr**

15-270-21  
21 cm - 8 1/4"

with pin  
mit Stift  
con pivote  
avec cheville  
con perno

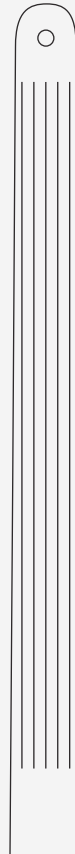

**15-271-29**

29 cm - 11 1/2"

Intestinal and anastomosis clamp forceps  
 Darm- und Anastomosenklemmen  
 Pinzas-clamps intestinales para anastomosis  
 Pinces-clamps intestinales età anastomose  
 Pinza clamp intestinale e anastomosi



De Martel  
 15-272-08  
 8.5 cm - 3 1/4"



De Martel-  
 Wolfson  
 15-273-23 23 cm - 9"



De Martel-  
 Wolfson  
 15-274-26 26 cm - 10 1/4"



De Martel-Wolfson  
 15-275-05 5 cm - 2"  
 15-276-07 7 cm - 2 3/4"  
 15-277-10 10 cm - 4"

Set of 3 clamps  
 Satz mit 3 Klemmen  
 Juego de 3 pinzas  
 Jeu de 3 clamps  
 Serie di 3 pezzi



Sims  
15-278-00  
x = 8 cm x 1.5 cm



15-279-00  
x = 8 cm x 1.5 mm



Mathieu  
15-280-19 19.5 cm - 7 3/4"  
x = 90 mm

Intestinal and anastomosis clamp forceps  
Darm- und Anastomosenklemmen  
Pinzas-clamps intestinales y para anastomosis  
Pinces-clamps intestinales età anastomose  
Pinza clamp intestinale e anastomosi

comed  
operate better with us



Pratt

15-281-20 20.5 cm - 8"

x = 8 cm x 2.5 cm



Pratt

15-282-22 22 cm - 8 3/4"

x = 11 cm x 2.5 cm



**Ives-Fansler**

15-283-09

x = 9 cm



**Kelly**

15-284-01 2.1 cm Ø

15-284-02 2.7 cm Ø

x = 5 cm



**Bensaude**

15-285-01 2 cm Ø

15-285-02 2.3 cm Ø

18.5 cm - 7 ¼"

x = 5.5 cm

Intestinal and anastomosis clamp forceps  
 Darm- und Anastomosenklemmen  
 Pinzas-clamps intestinales para anastomosis  
 Pincas-clamps intestinales età anastomose  
 Pinza clamp intestinale e anastomosi



**Hirschmann**

15-286-06	1.6 cm Ø	x = 6 cm
15-286-01	1.9 cm Ø	x = 7 cm
15-286-02	2.2 cm Ø	x = 9 cm

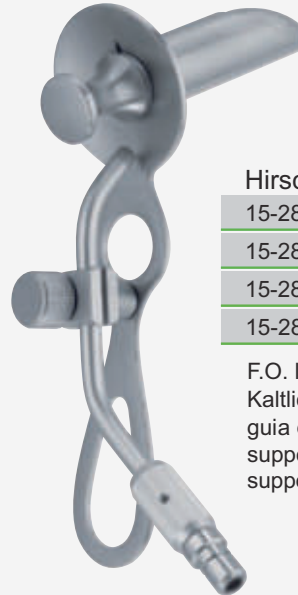

**Hirschmann**

15-287-01	1.6 cm Ø
15-287-02	1.9 cm Ø
15-287-03	2.4 cm Ø
15-287-04	2.5 cm Ø

F.O. light carrier, Wolf  
 Kaltlichtaufsatz, Wolf  
 guia de luz fría, Wolf  
 support lumière froide, Wolf  
 supporto per luce fredda, Wolf

**15-288-00**

Cold light,  
 Kaltlichtadapter,  
 Adaptator luz fria,  
 Adapteur lum. froide,  
 Adattatore luce freddo,

Rectal specula  
 Analspreizer  
 Espéculos rectales  
 Spéculums pour le rectum  
 Divaricatore anale



**Smith-Buie**

15-289-15	15 cm - 6"
x = 75 mm x 23 mm	
Max. spread 115 mm	
Max. Spreizweite 115 mm	
Apertura máxima 115 mm	
Écartement maximal 115 mm	
Apertura massima 115 mm	





Alan Parks

15-290-00

complete with 2 pair of blades and 1 center blade  
komplett mit 2 Paar Valven und 1 Mittelvalve  
completo con 2 juegos de valvas y 1 valva central  
complet avec 2 paires des valves et 1 valve centrale  
completo con 2 paia di valve e 1 valva centrale

15-292-02 2.2 cm x 7.5 cm

Lateral blades only (pair)  
Seitenvalven alleine (Paar)  
Valvas laterales solas (par)  
Valves latérales seules (paire)  
Valve laterali solo (paio)

15-294-02 2.2 cm x 9.5 cm

Lateral blades only (pair)  
Seitenvalven alleine (Paar)  
Valvas laterales solas (par)  
Valves latérales seules (paire)  
Valve laterali solo (paio)

15-295-02 2.5 cm x 9.5 cm

Central blade only  
Mittelvalve alleine  
Valva central sola  
Valve centrale seule  
Valva centrale solo



15-291-14 14 cm - 5 1/2"

complete with 2 pairs of blades and 1 center blade, with cold light connector Wolf  
komplett mit 2 Paar Valven und 1 Mittelvalve, mit Kaltlichtanschluss Wolf  
completo con 2 juegos de valvas y 1 valva central, con connector de luz fría Wolf  
complet avec 2 paires des valves et 1 valve centrale, avec raccord de lum. froide Wolf  
completo con 2 paia di valve e 1 valva centrale, con attacco di luce fredda Wolf

15-293-02

F.O. light carrier  
Kaltlicht-Aufsatz  
Soporte de luz fría  
Support lumière froide  
Supporto per luce fredda

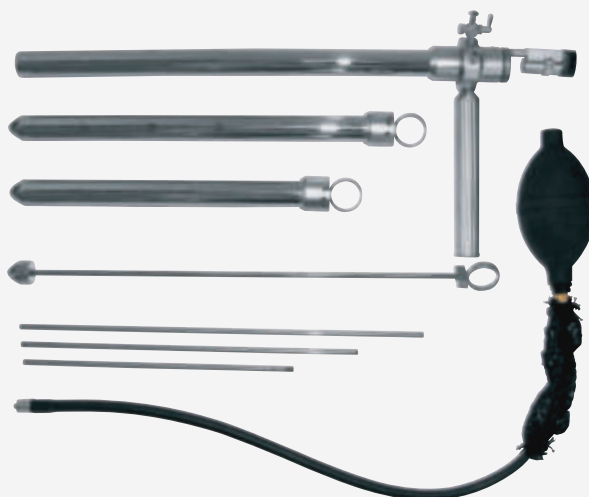

### Strauss

15-296-00

Cold-light rectoscope, complete:

F/O Rectoscope-head with two-way stop cock, lens cover and telescope handle,  
3 rectoscope-tubes 20 mm Ø 200 mm, 250 mm and 300 mm  
with obturator and F/O light-carrier Wolf, with double blower, with cold light connection

Kaltlicht-Rektoskop, komplett:

F/O Rektoskopkopf mit Zweiwegehahn, Verschlussdeckel, Teleskop und Griff,  
je 1 Rektoskoptubus in 200 mm, 250 mm und 300 mm mit 20 mm Ø,  
mit Obturator und F/O Lichtträger Wolf-Anschluss, Doppelgebläse mit Kaltlichteinrichtung

Rectoscopio de luz fría, completo:

F/O cabeza de rectoscopio, con robinete protector de lentes, óptica y mango,  
3 tubos de rectoscopia de 20 mm Ø, 200 mm, 250 mm y 300 mm de longitud,  
con obturador y conector de luz fría Wolf y soplador.

Rectoscope à lumière froide, complet:

F/O tête de rectoscope avec robinet, protecteur de lentille, optique et manche,  
3 tubes de rectoscope 20 mm Ø, 200 mm, 250 mm et 300 mm de longueur,  
avec mandrin et porte-lumière Wolf (F/Q) souffleur et connecteur de lumière froide.

Luce fredda-Re tt oscopio, completo

Testadi rettoscopio con fibre ottiche, con rubinetto a due vie, copri-lente e impugnatura per ottica,  
3 tubi per rettoscopio 20 mm Ø, 200 mm, 250 mm e 300 mm  
con otturatore e cavo luce insufflatore a doppia palla e connettore per cavo luce, allacciamento Wolf.

### Strauss

15-297-00

Cold light connector

Kaltlichtadapter

Raccord de lumière froide

Connector de luz fría

Attacco luce fredda

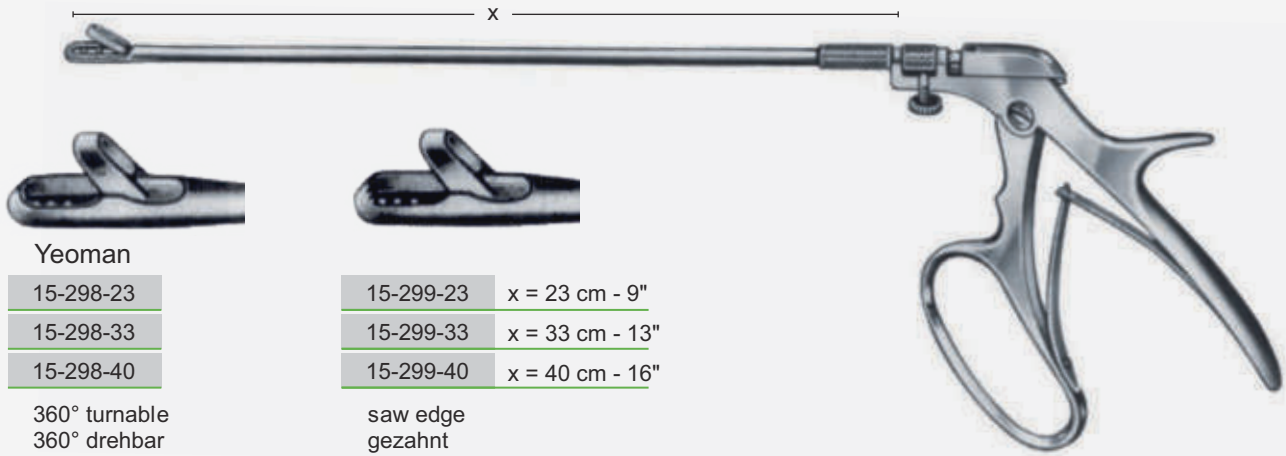

**Yeoman**

15-298-23

15-298-33

15-298-40

360° turnable  
360° drehbar  
rotativo de 360°  
rotative à 360°  
rotativa di 360°

15-299-23 x = 23 cm - 9"

15-299-33 x = 33 cm - 13"

15-299-40 x = 40 cm - 16"

saw edge  
gezahnt  
dentada  
dentelé  
dentata



**Turrel**

15-300-23

15-300-33

15-300-40

360° turnable  
360° drehbar  
rotativo de 360°  
rotative à 360°  
rotativa di 360°

15-301-23 x = 23 cm - 9"

15-301-33 x = 33 cm - 13"

15-301-40 x = 40 cm - 16"

saw edge  
gezahnt  
dentada  
dentelé  
dentata

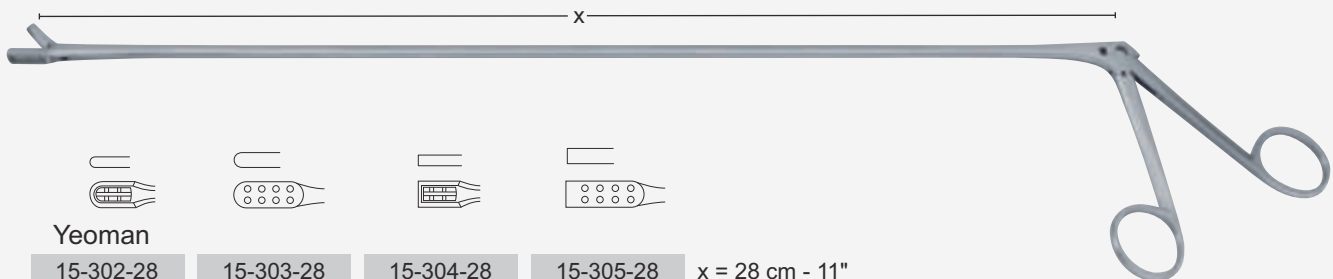

**Yeoman**

15-302-28

15-302-35

15-302-42

Fig. 1

15-303-28

15-303-35

15-303-42

Fig. 2

15-304-28

15-304-35

15-304-42

Fig. 3

15-305-28

15-305-35

15-305-42

Fig. 4

x = 28 cm - 11"

x = 35 cm - 13 3/4"

x = 42 cm - 16 1/2"

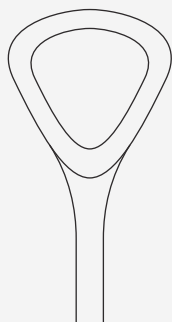

Luer

15-330-24 24.5 cm - 9 ¾"



Mc Givney

15-331-00

single curved  
1x gebogen  
curvadosimple  
courbé simple  
curvatura singola



15-332-19 19 cm - 7 ½"

double curved  
2x gebogen  
curvado doble  
courbé double  
curvatura doppia

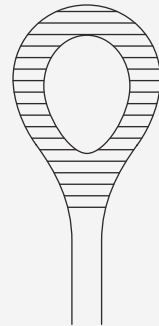

Heywood - Smith  
15-333-20 20 cm - 8"

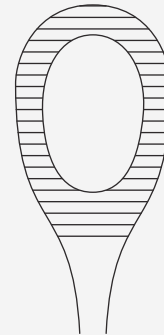

Heywood - Smith  
15-334-21 21 cm - 8 ¼"

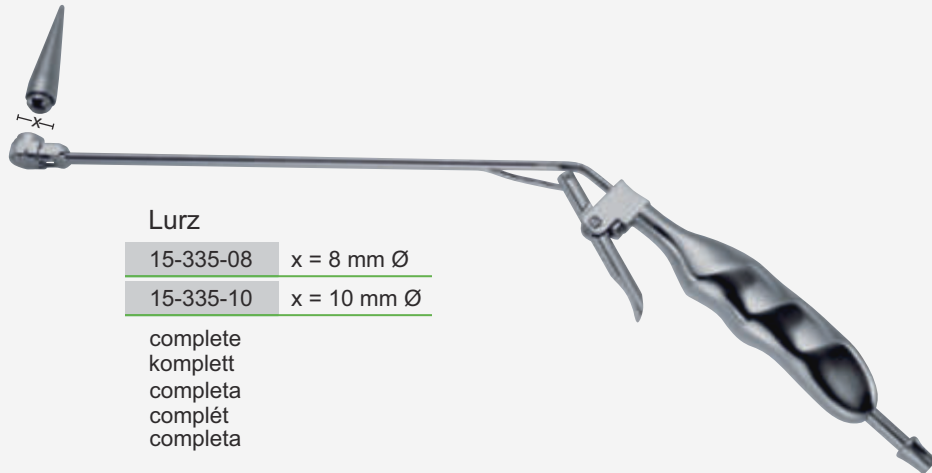

**Lurz**

15-335-08 x = 8 mm Ø

15-335-10 x = 10 mm Ø

complete  
 komplett  
 completa  
 complét  
 completa

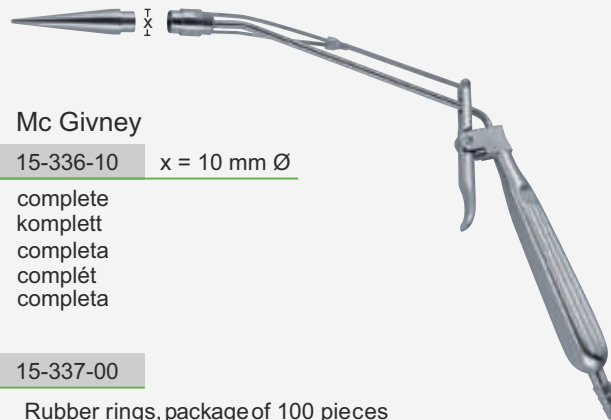

**Mc Givney**

15-336-10 x = 10 mm Ø

complete  
 komplett  
 completa  
 complét  
 completa



15-337-00

Rubber rings, package of 100 pieces  
 Gummiringe, Packung à 100 Stück  
 Anillos de goma para ligaduras, paquete de 100 piezas  
 Anneaux decaoutchouc à ligatures, paquet de 100 pièces  
 Anelli di gomma, pacchetto di 100 pezzi



**Rudd**

15-338-31 15-339-31 31.5 cm - 12 ½"

x = 12 mm Ø x = 12 mm Ø

complete Cone piece only  
 komplett Ladekegel allein  
 completa Cono solo  
 complét Cône seule  
 completa Cono solo



15-340-00

Rubber rings, package of 100 pieces  
 Gummiringe, Packung à 100 Stück  
 Anillos de goma para ligaduras, paquete de 100 piezas  
 Anneaux decaoutchouc à ligatures, paquet de 100 pièces  
 Anelli di gomma, pacchetto di 100 pezzi



Urology  
Urologie  
Urología  
Urologie  
Urologia

**comed**  
operate better with us

**16**



Randall

16-400-23

23 cm - 9"  
 Fig. 1



16-401-22

22 cm - 8 3/4"  
 Fig. 2

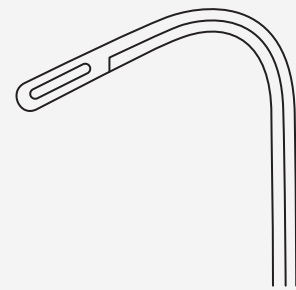

16-402-19

19 cm - 8 1/2"  
 Fig. 3

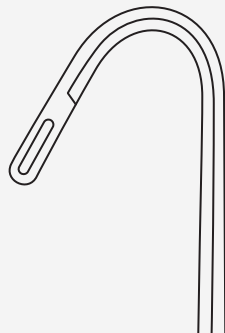

16-403-19

19 cm - 7 1/2"  
 Fig. 1

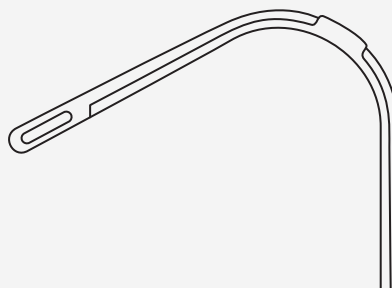

16-404-19

19 cm - 7 1/2"  
 Fig. 2

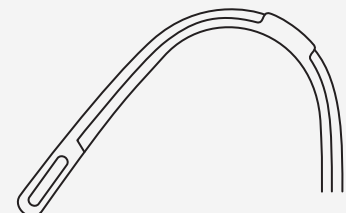

16-405-19

19 cm - 7 1/2"  
 Fig. 3



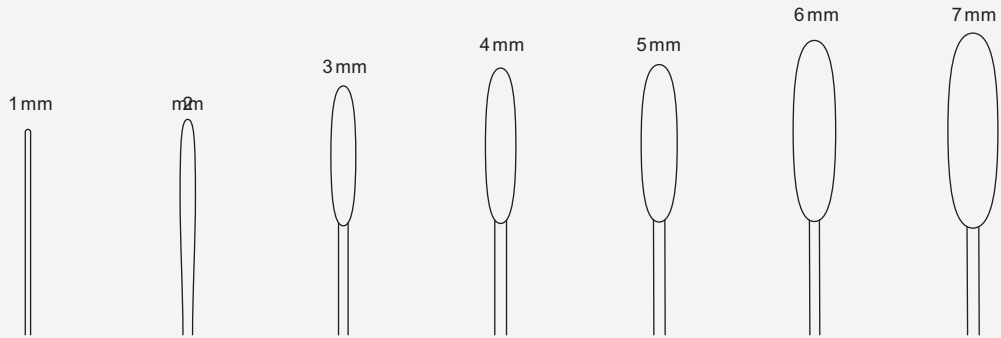

**Bakes**

16-406-30	16-407-30	16-408-30	16-409-30	16-410-30	16-411-30	16-412-30	30 cm - 12"
-----------	-----------	-----------	-----------	-----------	-----------	-----------	-------------

Fig. 1      Fig. 2      Fig. 3      Fig. 4      Fig. 5      Fig. 6      Fig. 7

malleable  
biegsam  
maleable  
malléable  
flessibile

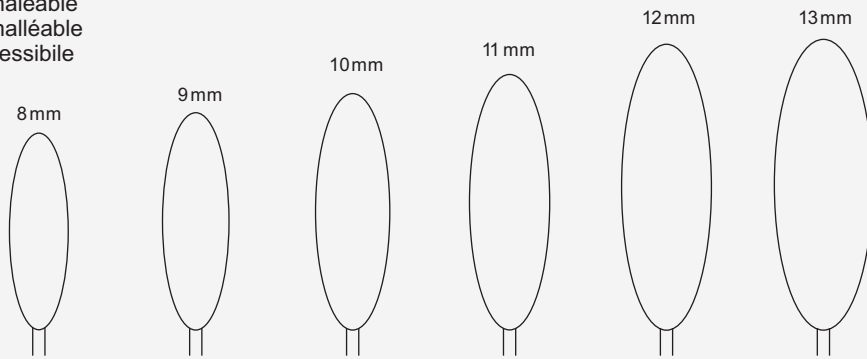

16-413-30	16-414-30	16-415-30	16-416-30	16-417-30	16-418-30	30 cm - 12"
-----------	-----------	-----------	-----------	-----------	-----------	-------------

Fig. 8      Fig. 9      Fig. 10      Fig. 11      Fig. 12      Fig. 13

16-406-00	Complete set of 13 pieces: 16-406-30 to 16-418-30
-----------	--

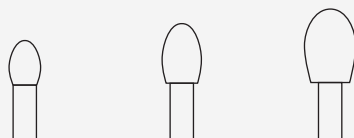

**Desjardins**

16-419-28	16-420-28	16-421-28	28 cm - 11"
-----------	-----------	-----------	-------------

Fig. 1      Fig. 2      Fig. 3

elastic  
federnd  
elastica  
élastique  
elastico



**Desjardins**

16-422-30

16-423-30

16-424-30

16-425-30

30 cm - 12"

Fig. 1  
 elastic  
 federnd  
 elastica  
 élastique  
 elastico

Fig. 2

Fig. 3

Fig. 4



**Moynihan**

16-426-34 34 cm - 13 1/2"

x = 5mm  
 malleable  
 biegsam  
 maleable  
 malléable  
 flessibile

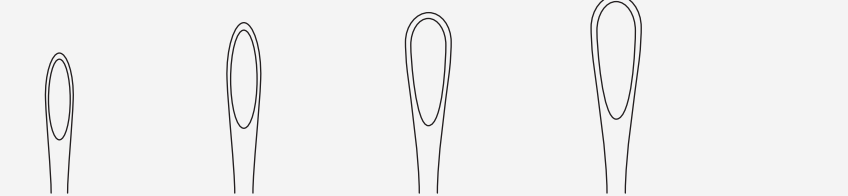

**Luer-Koerte**

16-427-32    16-428-32    16-429-32    16-430-32    32 cm - 12 ½"

Fig. 000

Fig. 00

Fig. 0

Fig. 1

malleable, blunt  
biegsam, stumpf  
maleable, roma  
malléable, mousse  
flessibile, smussa

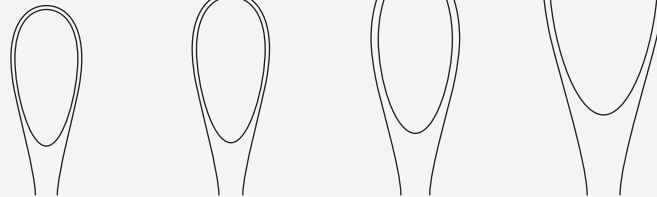

**Luer-Koerte**

16-431-32    16-432-32    16-433-32    16-434-32    32 cm - 12 ½"

Fig. 2

Fig. 3

Fig. 4

Fig. 5

malleable, blunt  
biegsam, stumpf  
maleable, roma  
malléable, mousse  
flessibile, smussa



**Mayo**

16-435-28    28 cm - 12"

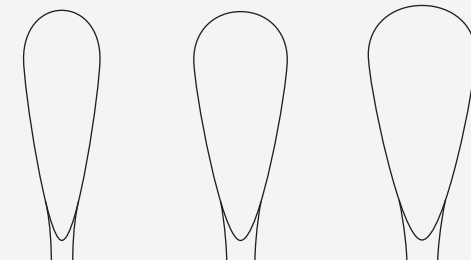
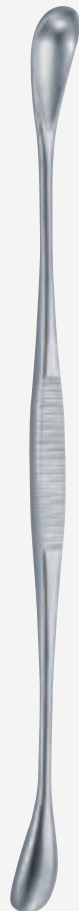

**Fergusson**

16-436-21    16-437-22    16-438-23  
21.5 cm - 8 ½"    22 cm - 8 ¾"    23.5 cm - 9 ¼"

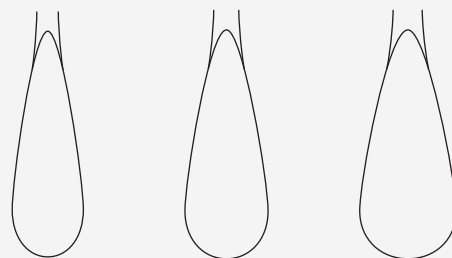

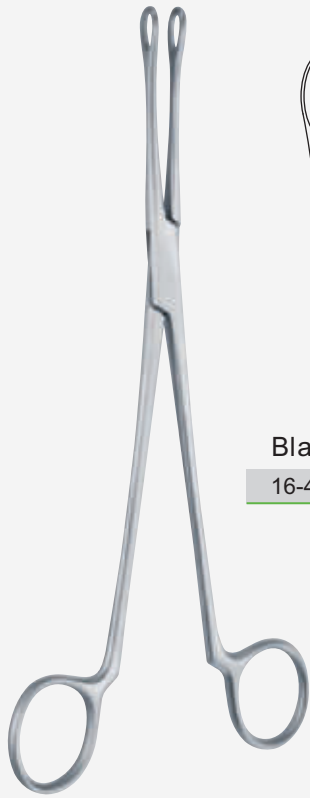

Blake

16-439-20



16-440-20 20 cm - 8"

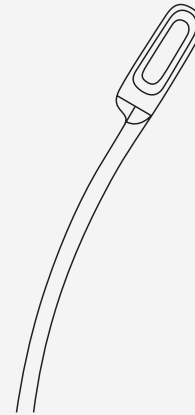
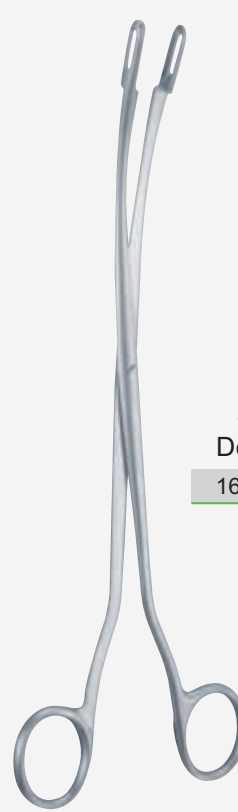

Desjardins

16-441-23

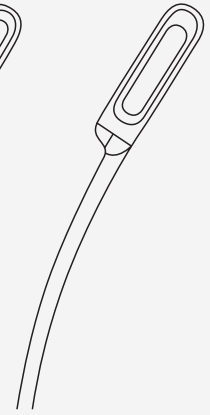

16-442-23 23 cm - 9"



Czerny

16-443-24 24.5 cm - 9 3/4"

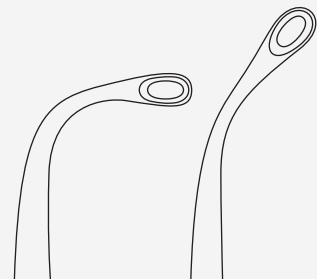
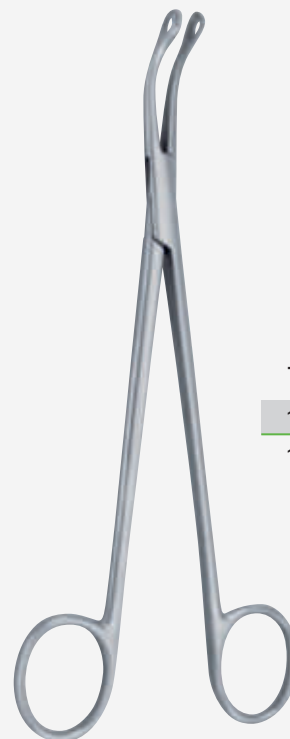

Turner-Warwick

16-444-18

18 cm - 7"

16-445-19

19 cm - 7 1/2"



Young  
 16-446-21 24 cm - 8 ¼"

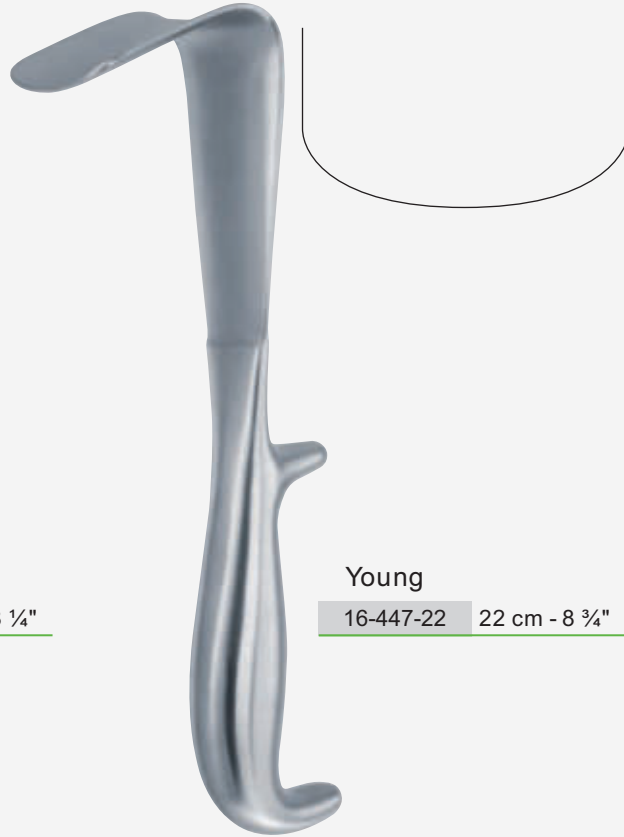

Young  
 16-447-22 22 cm - 8 ¾"

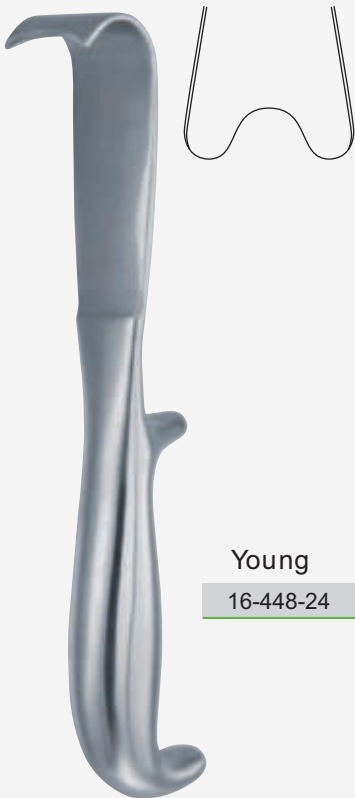

Young  
 16-448-24 21 cm - 8 ¼"



Young  
 16-449-22 22 cm - 8 ¾"

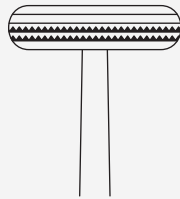
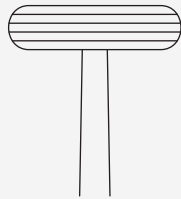

**Millin**

16-450-23

23 cm - 9"

16-451-23

23.5 cm - 9 ¼"

Capsule forceps for retropubic prostatectomy  
 Kapsel-fasszange zur retropubischen Prostatektomie  
 Pinza capsular para la prostatectomía retropúbica  
 Pince pour saisir les capsules pour la prostatectomie rétropubique  
 Pinza a capsula per prostatectomia retropubica



**Millin**

16-452-23

23 cm - 9"

Prostatic lobe holding forceps  
 Fasszange für die vorderen Lappen  
 Pinza para coger los lóbulos anteriores  
 Pince pour saisir les lambeaux  
 Pinza da presa per lobo prostatico

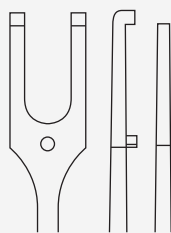

**Millin**

16-453-24

23 cm - 9"

24 cm - 9 ½"

Ligatur carrying forceps  
 Fadenführungszange  
 Pinza porta-ligaduras  
 Pince porte-fil  
 Pinza per fili di sutura

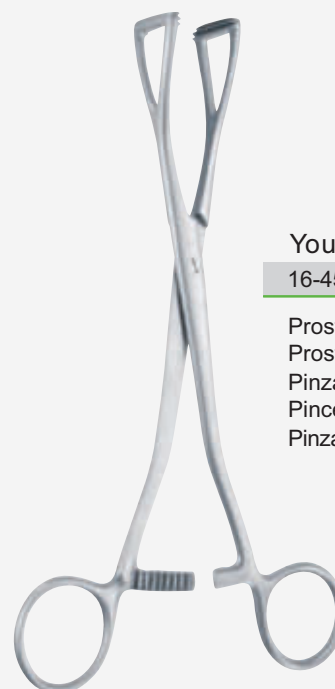

**Young**

16-454-20

22.5 cm - 8"

Prostate holding forceps  
 Prostata-Fasszange  
 Pinza para coger la próstata  
 Pince pour saisir la prostate  
 Pinza da presa per lobo prostatico



Thomson-Walker

16-455-00

complete with 2 pairs of lateral blades, 1 central blade  
komplett mit 2 Paar Seitenvalven, 1 Mittelvalve  
completo con 2 pares de valvas laterales, 1 valva central  
complet, avec 2 paires de valves latérales, 1 valve centrale  
completo, con 2 paia di valve laterali, 1 valva centrale



Millin

16-456-01

16-457-02

16-458-03

16-459-04

16-460-05

5.7 cm x 2.5 cm

5 cm x 2.5 cm

12 cm x 4.5 cm

complete  
komplett  
completa  
complét  
completa

Spreader, only  
Sperrer, allein  
Retractor, solo  
Retractor, seul  
Divaricatore, solo

2 Blades  
2 Blätter  
2 Valvas  
2 Valves  
2 Valve

2 Blades  
2 Blätter  
2 Valvas  
2 Valves  
2 Valve

1 Center blade  
1 Mittelblatt  
1 Valva central  
1 Valve centrale  
1 Valva centrale

16-461-00

complete with cold light carrier  
komplett mit Kaltlichtaufsatz  
completa con guia de luz fria  
complét avec guide de lumière froide  
completa con portaluca fredda

16-462-00

Cold light carrier  
Kaltlichtaufsatz  
Guia de luz fria  
Guide de lumière froide  
Porta luce fredda, solo



Legueu  
16-463-00



Judd-Masson  
16-464-00



Legueu  
16-465-27 27 cm - 10 3/4"  
x = 3.5 cm



Kocher  
16-466-26 26 cm - 10 1/4"  
x = 6.7 cm



Millin  
16-467-28  
28.5 cm - 11 1/4"





Dittel

16-468-01	2 ⅓ mm Ø	8 Charr./Fr.
16-468-02	2 mm Ø	9 Charr./Fr.
16-468-03	3 ⅓ mm Ø	10 Charr./Fr.
16-468-04	3 ⅔ mm Ø	11 Charr./Fr.
16-468-05	4 mm Ø	12 Charr./Fr.
16-468-06	4 ⅓ mm Ø	13 Charr./Fr.
16-468-07	4 ⅔ mm Ø	14 Charr./Fr.
16-468-08	5 mm Ø	15 Charr./Fr.
16-468-09	5 ⅓ mm Ø	16 Charr./Fr.
16-468-10	5 ⅔ mm Ø	17 Charr./Fr.
16-468-11	6 mm Ø	18 Charr./Fr.
16-468-12	6 ⅓ mm Ø	19 Charr./Fr.
16-468-13	6 ⅔ mm Ø	20 Charr./Fr.
16-468-14	7 mm Ø	21 Charr./Fr.
16-468-15	7 ⅓ mm Ø	22 Charr./Fr.
16-468-16	7 ⅔ mm Ø	23 Charr./Fr.
16-468-17	8 mm Ø	24 Charr./Fr.
16-468-18	8 ⅓ mm Ø	25 Charr./Fr.
16-468-19	8 ⅔ mm Ø	26 Charr./Fr.
16-468-20	9 mm Ø	27 Charr./Fr.
16-468-21	9 ⅓ mm Ø	28 Charr./Fr.
16-468-22	9 ⅔ mm Ø	29 Charr./Fr.
16-468-23	10 mm Ø	30 Charr./Fr.
16-468-24	10 ⅓ mm Ø	32 Charr./Fr.
16-468-25	11 mm Ø	33 Charr./Fr.
16-468-26	11 ⅓ mm Ø	34 Charr./Fr.
16-468-27	12 mm Ø	36 Charr./Fr.

22 cm - 8 ¾"

straight  
gerade  
recta  
droit  
rette



Dittel

16-469-01	2 ⅓ mm Ø	8 Charr./Fr.
16-469-02	2 mm Ø	9 Charr./Fr.
16-469-03	3 ⅓ mm Ø	10 Charr./Fr.
16-469-04	3 ⅔ mm Ø	11 Charr./Fr.
16-469-05	4 mm Ø	12 Charr./Fr.
16-469-06	4 ⅓ mm Ø	13 Charr./Fr.
16-469-07	4 ⅔ mm Ø	14 Charr./Fr.
16-469-08	5 mm Ø	15 Charr./Fr.
16-469-09	5 ⅓ mm Ø	16 Charr./Fr.
16-469-10	5 ⅔ mm Ø	17 Charr./Fr.
16-469-11	6 mm Ø	18 Charr./Fr.
16-469-12	6 ⅓ mm Ø	19 Charr./Fr.
16-469-13	6 ⅔ mm Ø	20 Charr./Fr.
16-469-14	7 mm Ø	21 Charr./Fr.
16-469-15	7 ⅓ mm Ø	22 Charr./Fr.
16-469-16	7 ⅔ mm Ø	23 Charr./Fr.
16-469-17	8 mm Ø	24 Charr./Fr.
16-469-18	8 ⅓ mm Ø	25 Charr./Fr.
16-469-19	8 ⅔ mm Ø	26 Charr./Fr.
16-469-20	9 mm Ø	27 Charr./Fr.
16-469-21	9 ⅓ mm Ø	28 Charr./Fr.
16-469-22	9 ⅔ mm Ø	29 Charr./Fr.
16-469-23	10 mm Ø	30 Charr./Fr.
16-469-24	10 ⅓ mm Ø	32 Charr./Fr.
16-469-25	11 mm Ø	33 Charr./Fr.
16-469-26	11 ⅓ mm Ø	34 Charr./Fr.
16-469-27	12 mm Ø	36 Charr./Fr.

22 cm - 8 ¾"

curved  
gebogen  
curva  
courbe  
curve

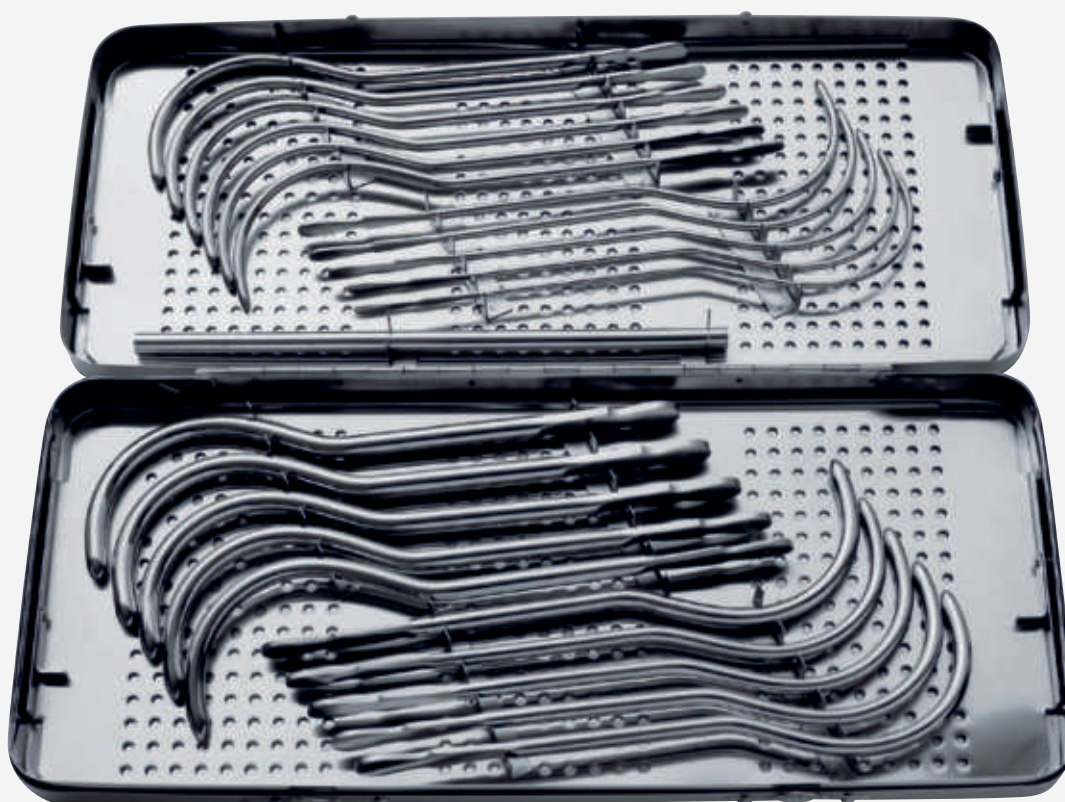

### Guyon

16- 170-00 42 cm x 17.5 cm x 4 cm

complete, Charr. 10–30, in steel case  
komplett, Charr. 10–30, im Edelstahl-Etui  
completa, Charr. 10–30, en caja metálica  
complet, Charr. 10–30, en étui métallique  
completa, Charr. 10–30, in astuccio metallico



**Otis**

16-471-00

complete in wooden case consisting:

16-471-01 1 Dilator

16-471-02 2 Knives

16-471-03 1 Conical tip

16-471-04 1 Flat tip

16-471-05 1 Ball tip



16-471-03  
Conical tip

16-471-04  
Flat tip

16-471-05  
Ball tip

16-471-01  
Dilator

16-471-02  
Knife

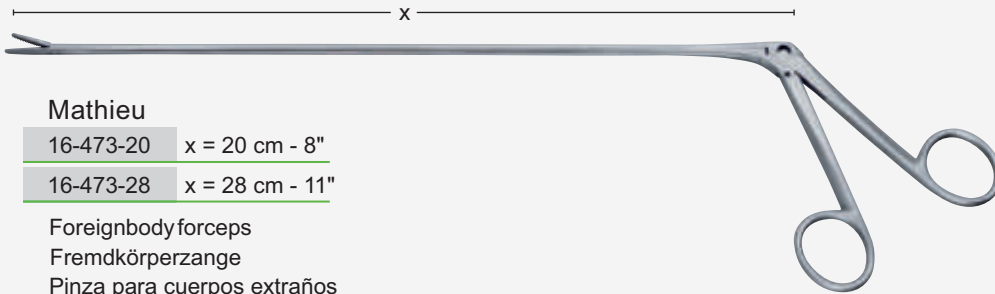

**Mathieu**

16-473-20 x = 20 cm - 8"

16-473-28 x = 28 cm - 11"

Foreignbody forceps  
 Fremdkörperzange  
 Pinza para cuerpos extraños  
 Pince à corps étrangers  
 Pinza per corpi estranei



**Haken**

16-474-16 16 cm - 6 ¼"

Hook for the spermaticcord  
 Samenstrang-Haken  
 Grancho para el cordón espermático  
 Crochet pour le cordon spermatique  
 Uncino per dotto spermatico



**Guyon**

16-475-39

39 cm - 15 ½"

16-476-35

35 cm - 13 ¾"

Mandrin for rubber catheters  
 Katheterspanner  
 Mandril para catéteres  
 Mandrin pour cathéters  
 Introduttore per catheteri

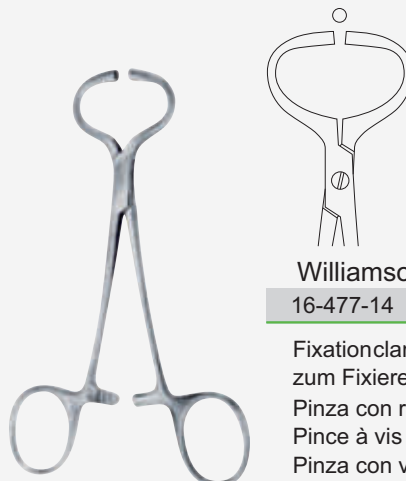

**Williamson**

16-477-14 14.5 cm - 5 ¾"

Fixation clamp for the spermaticcord  
 zum Fixieren des Samenstranges  
 Pinza con rosca para fijación el cordon espermático  
 Pince à vis pour fixation du cordon spermatique  
 Pinza con vite per fissare il funicolo spermatico



Blacke

16-478-01	8 mm Ø
16-478-02	11 mm Ø
16-478-03	13 mm Ø
16-478-04	16 mm Ø
16-478-05	21 mm Ø
16-478-06	26 mm Ø
16-478-07	32 mm Ø

Circumcisioninstrument  
Beschneidungsklemme  
Instrumento para circuncisión  
Instrument de circoncision  
Strumento di circoncisione



Morgan

16-479-07 7.5 cm - 3"

Circumcisioninstrument  
Beschneidungsklemme  
Instrumento para circuncisión  
Instrument de circoncision  
Strumento di circoncisione

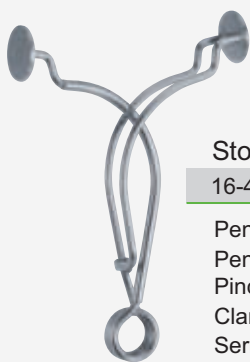

**Stockmann**

16-480-00

Penisklemme  
Penisclamp  
Pince pour le pénis  
Clamp para el pene  
Serrapene



**Strauss**

16-481-00

Penisklemme  
Penisclamp  
Pince pour le pénis  
Clamp para el pene  
Serrapene



Gynecology  
Gynäkologie  
Ginecología  
Gynécologie  
Ginecologia

comed  
operate better with us

17



Cusco

17-601-01	7.5 cm x 3.2 cm	Small
17-601-02	8.5 cm x 3.5 cm	Medium
17-601-03	10 cm x 3.5 cm	Large
17-601-04	7.5 cm x 1.7 cm	Extra small

German pattern



Cusco

17-602-01	7.5 cm x 3.2 cm	Small
17-602-02	8.5 cm x 3.5 cm	Medium
17-602-03	10 cm x 3.5 cm	Large

German pattern

17-602-04	7.5 cm x 3.2 cm	Small
17-602-05	8.5 cm x 3.5 cm	Medium
17-602-06	10 cm x 3.5 cm	Large

Swiss pattern

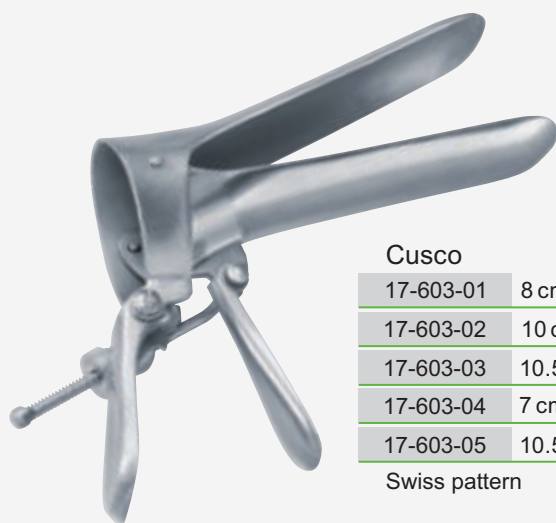

Cusco

17-603-01	8 cm x 2.2 cm	Small
17-603-02	10 cm x 2.5 cm	Medium
17-603-03	10.5 cm x 2.7 cm	Large
17-603-04	7 cm x 3 cm	Extra small
17-603-05	10.5 cm x 4 cm	Extra large

Swiss pattern

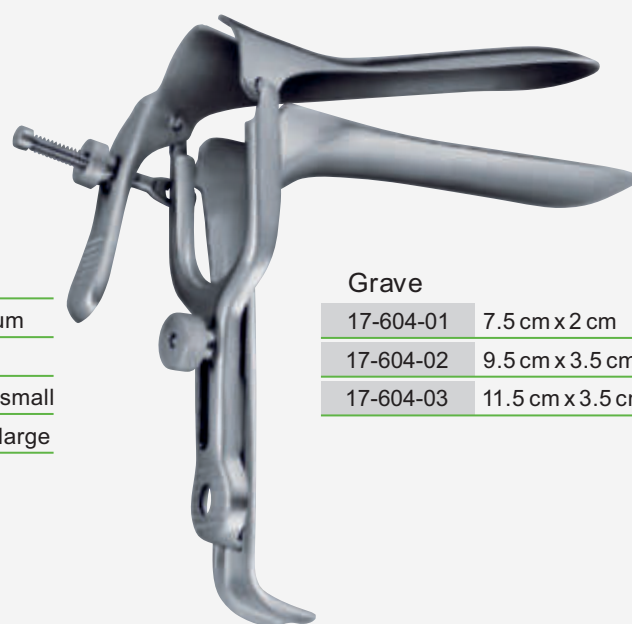

Grave

17-604-01	7.5 cm x 2 cm
17-604-02	9.5 cm x 3.5 cm
17-604-03	11.5 cm x 3.5 cm



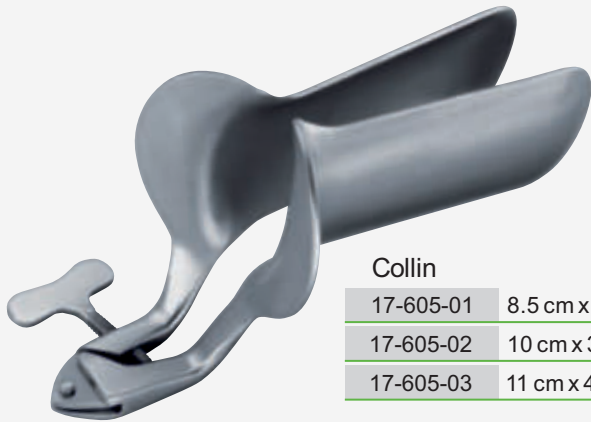

**Collin**

17-605-01	8.5 cm x 3 cm
17-605-02	10 cm x 3.5 cm
17-605-03	11 cm x 4 cm

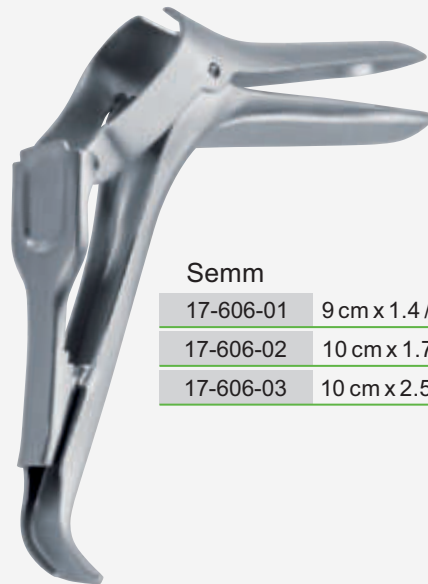

**Semm**

17-606-01	9 cm x 1.4 / 1.8 cm
17-606-02	10 cm x 1.7 / 2 cm
17-606-03	10 cm x 2.5 / 3 cm

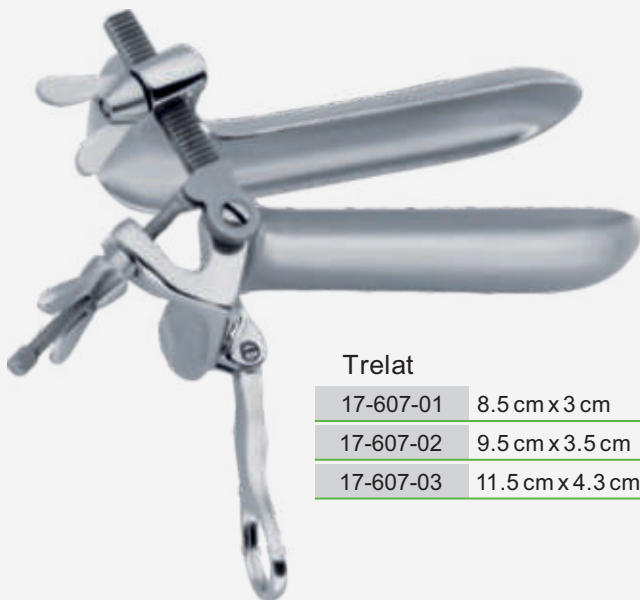

**Trelat**

17-607-01	8.5 cm x 3 cm
17-607-02	9.5 cm x 3.5 cm
17-607-03	11.5 cm x 4.3 cm

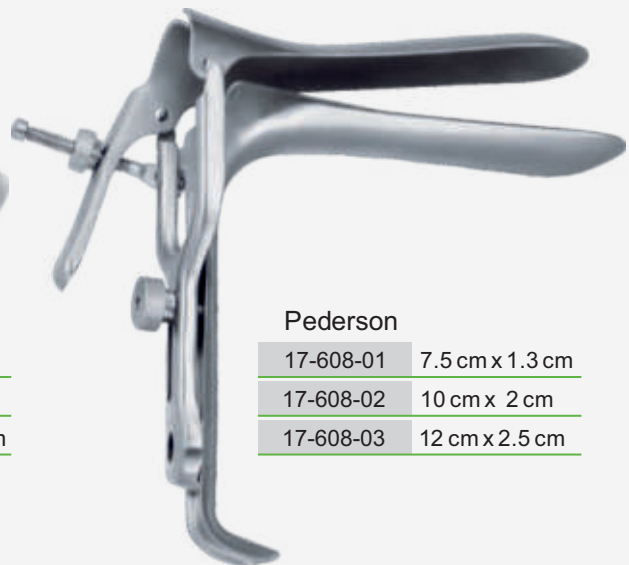

**Pederson**

17-608-01	7.5 cm x 1.3 cm
17-608-02	10 cm x 2 cm
17-608-03	12 cm x 2.5 cm



**Kristeller**

17-609-01	7 cm x 2.7 cm
17-609-02	8 cm x 3 cm
17-609-03	9 cm x 3.6 cm
17-609-04	11 cm x 2.7 cm
17-609-05	11 cm x 3 cm
17-609-06	11 cm x 3.6 cm

Speculum  
 Spekulum  
 Espéculo  
 Spéculum  
 Specolo



**Kristeller**

17-610-01	7.5 cm x 2.3 cm
17-610-02	8.5 cm x 2.6 cm
17-610-03	10 cm x 3.2 cm
17-610-04	11.5 cm x 2.3 cm
17-610-05	11.5 cm x 2.6 cm
17-610-06	11.5 cm x 3.2 cm

Retractor  
 Halter  
 Valva  
 Valve  
 Valve



**17-611-01**

17-611-02
17-611-03
17-611-04
17-611-05
17-611-06

Set  
 Satz  
 Juego  
 Jeu  
 Serie

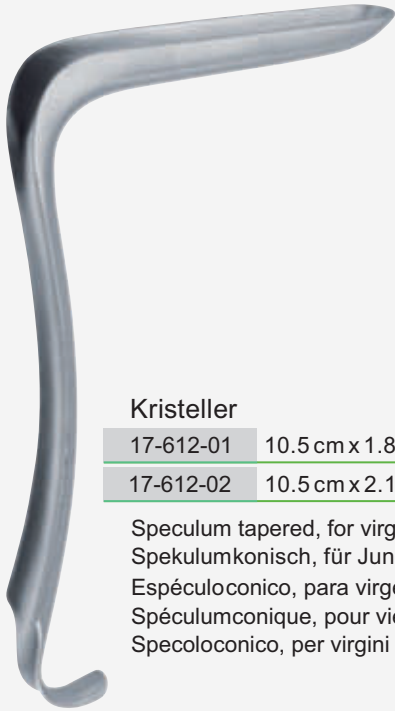

**Kristeller**

17-612-01 10.5 cm x 1.8 cm

17-612-02 10.5 cm x 2.1 cm

Speculum tapered, for virgins  
Spekulumkonisch, für Jungfrauen  
Espéculoconico, para vírgenes  
Spéculumconique, pour vierges  
Specoloconico, per virgini

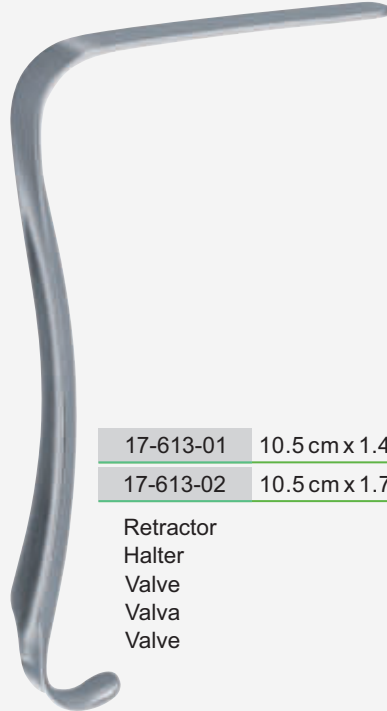

17-613-01 10.5 cm x 1.4 cm

17-613-02 10.5 cm x 1.7 cm

Retractor  
Halter  
Valve  
Valva  
Valve



17-614-01

17-614-02

Set  
Satz  
Jeu  
Juego  
Serie



**Jackson**

17-615-01 7.5 cm x 3.5 cm

17-615-02 7.5 cm x 4 cm

17-615-03 9 cm x 3.5 cm

17-615-04 9 cm x 4 cm

17-615-05 10 cm x 3.5 cm

17-615-06 10 cm x 4 cm



**Auvard**

17-616-22

22 cm - 8 3/4"  
8 cm x 3.8 cm



**Sims**

17-617-01	6 cm x 2.5 cm / 3 cm
17-617-02	7 cm x 3 cm / 3.5 cm
17-617-03	8 cm x 3.5 cm / 4 cm
17-617-00	Set of 3



**Kallmorgen**

17-618-01	7 cm x 4 cm
17-618-02	9 cm x 4 cm

Speculum  
 Spekulum  
 Espéculo  
 Spéculum  
 Specolo



17-619-01	7 cm x 3.3 cm
17-619-02	9 cm x 3.3 cm

Retractor  
 Halter  
 Valva  
 Valve  
 Valve



17-620-01	
17-620-02	

Set  
 Satz  
 Juego  
 Jeu  
 Serie



**Landau**

17-621-01 10 cm x 2.8 cm

17-621-02 11 cm x 3.8 cm

29 cm - 11 ½"



**Breisky**

17-622-01 13 cm x 2 cm

17-622-02 13 cm x 2.5 cm

17-622-03 13 cm x 3 cm

17-622-04 13 cm x 3.5 cm

17-622-05 13 cm x 4 cm

30 cm - 12"

Vienna pattern  
Wiener Modell  
Modelo Vienna  
Modèle Vienne  
Modello Vienna



**Breisky**

17-623-01 10 cm x 2 cm

17-623-02 10 cm x 2.5 cm

17-623-03 10 cm x 3 cm

17-623-04 10 cm x 3.5 cm

17-623-05 10 cm x 4 cm

30 cm - 12"



**Breisky**

17-624-01 16 cm x 4 cm

17-624-02 18 cm x 4 cm

35 cm - 13 ¾"



17-625-01

Fig. 1  
8 cm x 3 cm

17-626-02

Fig. 2  
8 cm x 3.5 cm

17-627-03

Fig. 3  
9 cm x 4 cm

17-628-04

Fig. 4  
5.5 cm x 4 cm / 6 cm

17-629-05

Fig. 5  
7 cm x 4.5 cm / 7 cm

Set

17-630-00	Set consisting of:
	Blades 17-625-01 to 17-629-05
17-631-01	Scherback 400 g
17-632-00	Holder



Scherback

17-631-01 400 g

17-631-02 800 g

Holder

17-632-00

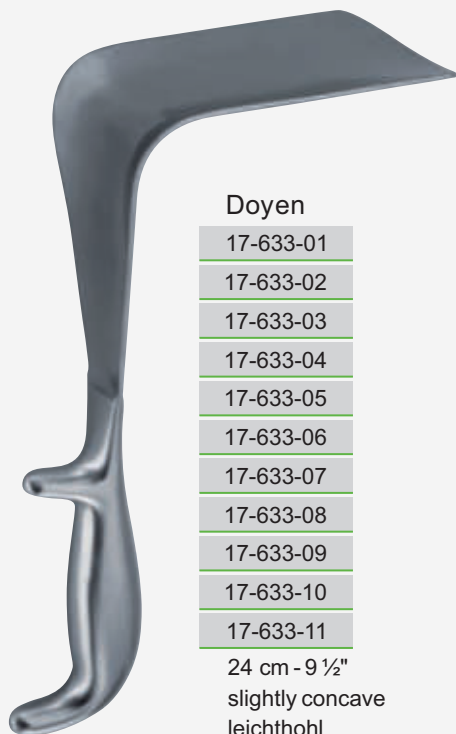

Doyen

- 17-633-01
- 17-633-02
- 17-633-03
- 17-633-04
- 17-633-05
- 17-633-06
- 17-633-07
- 17-633-08
- 17-633-09
- 17-633-10
- 17-633-11

24 cm - 9 1/2"  
 slightly concave  
 leichthohl  
 ligeramente concava  
 légèrement concave  
 leggermente concavo



- 17-634-01 5.5 cm x 3.5 cm
- 17-634-02 7.5 cm x 3.5 cm
- 17-634-03 11.5 cm x 3.5 cm
- 17-634-04 5.5 cm x 4.5 cm
- 17-634-05 7.5 cm x 4.5 cm
- 17-634-06 11.5 cm x 4.5 cm
- 17-634-07 16 cm x 4.5 cm
- 17-634-08 5.5 cm x 6 cm
- 17-634-09 7.5 cm x 6 cm
- 17-634-10 11.5 cm x 6 cm
- 17-634-11 16 cm x 6 cm

24 cm - 9 1/2"  
 mediumconcave  
 halbhoohl  
 semi concava  
 semi concave  
 semi concavo



**Kogan**

17-635-24 24 cm - 9 ½"

with scale-ratchet and fixation screw  
mit Skalensperre und Stellschraube  
con cremallera graduada y tornillo fijación  
avec crémaillère à échelle et vis à fixation  
con cremagliera graduata e vite di fissaggio



**Kogan**

17-636-24

24 cm - 9 ½"



**Kogan-modif.**

17-637-01 x = 4 mm y = 8 mm

17-637-02 x = 2 mm y = 4 mm

28 cm - 11"

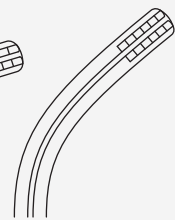
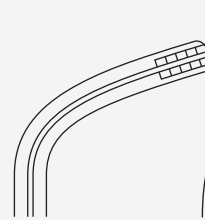
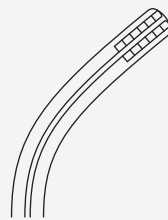
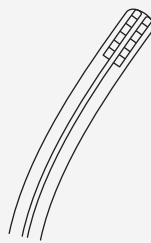

**Mazler**

17-638-01	17-639-01	17-640-01	17-641-01	17-642-01	21 cm - 8 ¼"
17-638-02	17-639-02	17-640-02	17-641-02	17-642-02	24 cm - 9 ½"
17-638-03	17-639-03	17-640-03	17-641-03	17-642-03	30 cm - 12"
17-638-04	17-639-04	17-640-04	17-641-04	17-642-04	35 cm - 13 ¼"

S-curved  
 S-förmig gebogen  
 curva en S  
 coube en S  
 curva a forma di S



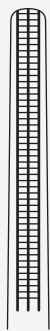

Rogers

17-643-22

Fig.1  
22 cm - 8 3/4"

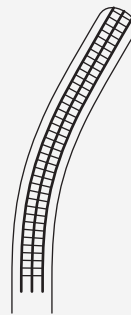

17-644-21

Fig.2  
21.5 cm - 8 1/2"

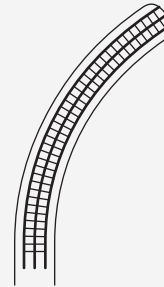

17-645-21

Fig.3  
21 cm - 8 1/4"

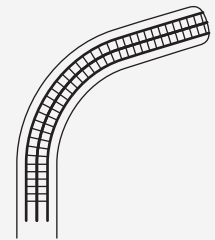

17-646-20

Fig.4  
20.5 cm - 8"

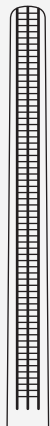

Rogers

17-647-25

Fig.1  
25 cm - 9 3/4"

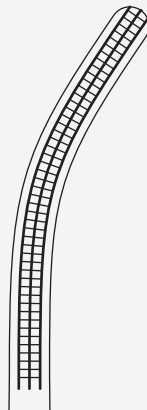

17-648-25

Fig.2  
25 cm - 9 3/4"

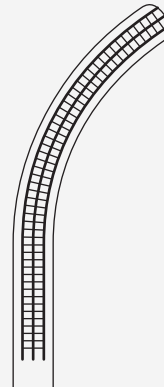

17-649-24

Fig.3  
24.5 cm - 9 3/4"

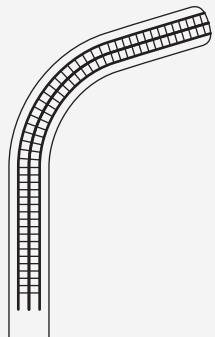

17-650-23

Fig.4  
23 cm - 9"



**Valleix**

17-651-25

25 cm - 9 ¾"  
 graduated, with slider  
 graduert, mit Schieber  
 graduado, con cursor  
 gradué, avec curseur  
 graduato, con cursore



**Galabins**

17-363-29

29.5 cm - 11 ¼"  
 Malleable  
 Tip Ø 3.6 mm

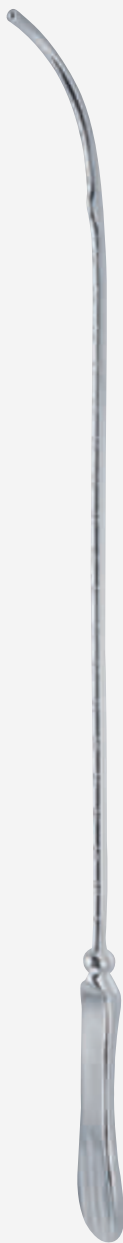

**Martin**

17-652-32

rigid  
 fest  
 rigido  
 rigide  
 rigido

17-653-32

malleable  
 biegsam  
 maleable  
 malléable  
 malleabile

32 cm - 12 ½"



**Sims**

17-654-32

rigid  
 fest  
 rigido  
 rigide  
 rigido

17-655-32

malleable  
 biegsam  
 maleable  
 malléable  
 malleabile

32 cm - 12 ½"



**Jorge**

17-191-09

9.5 cm - 3 3/4"



**Saundre**

17-407-32

32 cm - 12 1/2"



**Hegar**

17-656-01	1.0 mm Ø	17-657-01	10.0 mm Ø	17-658-01	20.0 mm Ø
17-656-02	1.5 mm Ø	17-657-02	10.5 mm Ø	17-658-02	21.0 mm Ø
17-656-03	2.0 mm Ø	17-657-03	11.0 mm Ø	17-658-03	22.0 mm Ø
17-656-04	2.5 mm Ø	17-657-04	11.5 mm Ø	17-658-04	23.0 mm Ø
17-656-05	3.0 mm Ø	17-657-05	12.0 mm Ø	17-658-05	24.0 mm Ø
17-656-06	3.5 mm Ø	17-657-06	12.5 mm Ø	17-658-06	25.0 mm Ø
17-656-07	4.0 mm Ø	17-657-07	13.0 mm Ø	17-658-07	26.0 mm Ø
17-656-08	4.5 mm Ø	17-657-08	13.5 mm Ø	17-658-08	27.0 mm Ø
17-656-09	5.0 mm Ø	17-657-09	14.0 mm Ø	17-658-09	28.0 mm Ø
17-656-10	5.5 mm Ø	17-657-10	14.5 mm Ø	17-658-10	29.0 mm Ø
17-656-11	6.0 mm Ø	17-657-11	15.0 mm Ø	17-658-11	30.0 mm Ø
17-656-12	6.5 mm Ø	17-657-12	15.5 mm Ø		
17-656-13	7.0 mm Ø	17-657-13	16.0 mm Ø		
17-656-14	7.5 mm Ø	17-657-14	16.5 mm Ø		
17-656-15	8.0 mm Ø	17-657-15	17.0 mm Ø		
17-656-16	8.5 mm Ø	17-657-16	17.5 mm Ø		
17-656-17	9.0 mm Ø	17-657-17	18.0 mm Ø		
17-656-18	9.5 mm Ø	17-657-18	18.5 mm Ø		
		17-657-19	19.0 mm Ø		
		17-657-20	19.5 mm Ø		

**Hegar**

17-659-01	4 mm - 17 mm Ø	14
17-659-02	1 mm - 26 mm Ø	26

Set, in rexine pouch  
Set, im Rexinbeutel  
Juego, en bolsa rexine  
Set, dans pochette rexine  
Set, in busta di rexine

Pieces per set  
Stück per Satz  
Piezas para juego  
Pièces per jeu  
Pezzi per serie



#### Hegar

17-660-01	4 mm - 17 mm Ø	14
17-660-02	1 mm - 26 mm Ø	26

Set, in metal case	Pieces per set
Satz, in Metalletui	Stück per Satz
Juego, ed caja de metal	Piezas para juego
Jeu, en boîte de métal	Pièces per jeu
Serie, con astuccio metallico	Pezzi per serie



**Hegar**

17-661-01	1/2 mm Ø
17-661-02	3/4 mm Ø
17-661-03	5/6 mm Ø
17-661-04	7/8 mm Ø
17-661-05	9/10 mm Ø
17-661-06	11/12 mm Ø
17-661-07	13/14 mm Ø
17-661-08	15/16 mm Ø
17-661-09	17/18 mm Ø
17-661-10	19/20 mm Ø
17-661-11	21/22 mm Ø
17-661-12	23/24 mm Ø
17-661-13	25/26 mm Ø

**Hegar**

17-662-01	3/4 mm - 17/18 mm Ø	8
17-662-02	1/2 mm - 25/26 mm Ø	13

Set, in rexine pouch  
Set, im Rexinbeutel  
Juego, en bolsa rexine  
Set, dans pochette rexine  
Set, in busta di rexine

Pieces per set  
Stück per Satz  
Piezas para juego  
Pièces per jeu  
Pezzi per serie



**Hegar**

17-663-01	3/4 mm - 17/18 mm Ø	8 pieces set
-----------	---------------------	--------------

Set in canvas roll  
Satz in Stoffrolltasche  
Juego en bolsa de tela  
Jeu en poche de textile  
Serie in astuccio di tela



17-664-01	3/4 mm - 17/18 mm Ø	8
17-664-02	1/2 mm - 25/26 mm Ø	13

Set, in metal case  
Satz, in Metalletui  
Juego, en caja de metal  
Jeu, en boîte de métal  
Serie, in astuccio metallico

Pieces per set  
Stück per Satz  
Piezas para juego  
Pièces per jeu  
Pezzi per serie



**Hank**

17-665-01	Fig. 19 / 10	4.5 / 5.0 mm Ø
17-665-02	Fig. 11 / 12	5.5 / 6.0 mm Ø
17-665-03	Fig. 13 / 14	6.5 / 7.0 mm Ø
17-665-04	Fig. 15 / 16	7.5 / 8.0 mm Ø
17-665-05	Fig. 17 / 18	8.5 / 9.0 mm Ø
17-665-06	Fig. 19 / 20	9.5 / 10.0 mm Ø

**Hank**

17-666-01	4.5 / 5mm	9.5 / 10 mm Ø	6
-----------	-----------	---------------	---

Set, in rexine pouch  
 Set, im Rexinbeutel  
 Juego, en bolsa rexine  
 Set, dans pochette rexine  
 Set, in busta di rexine

Pieces per set  
 Stück per Satz  
 Piezas para juego  
 Pièces per jeu  
 Pezzi per serie



**Hank**

17-667-01	4.5 / 5mm	9.5 / 10 mm Ø	6
-----------	-----------	---------------	---

Set, in canvas roll  
 Satz, in Stoffrolltasche  
 Jeu, en poche de textile  
 Juego, en bolsa de tela  
 Serie, in astuccio di tela

Pieces per set  
 Stück per Satz  
 Pièces per jeu  
 Piezas para juego  
 Pezzi per serie



**Braun**

17-668-28
-----------

28 cm - 11"

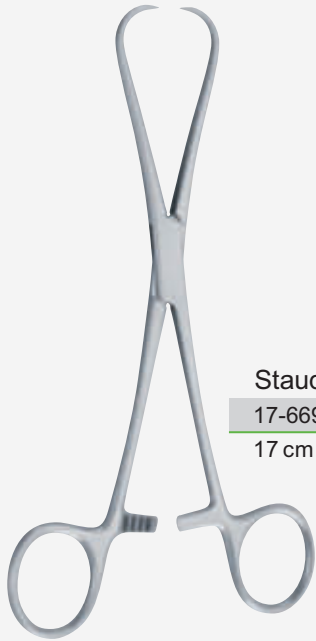

**Staude-Moore**  
17-669-17  
17 cm - 6 3/4"

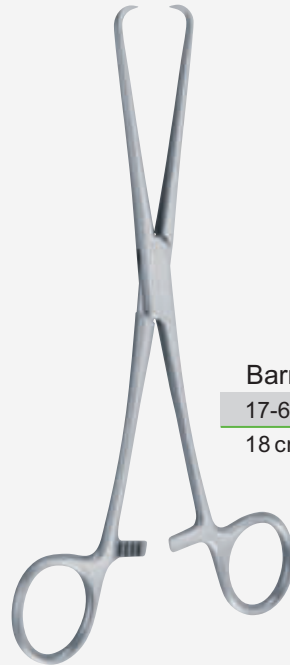

**Barrett**  
17-670-18  
18 cm - 7"

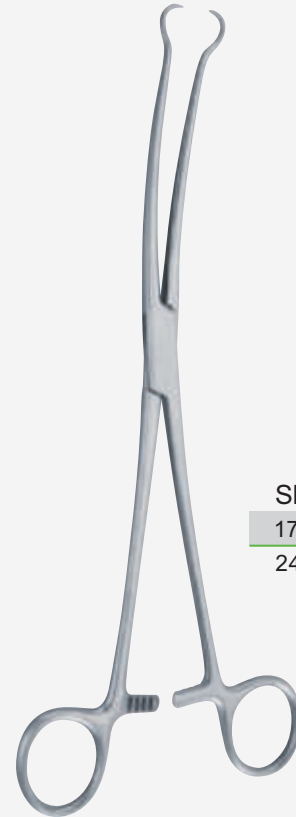

**Skene**  
17-671-24  
24 cm - 9 1/2"

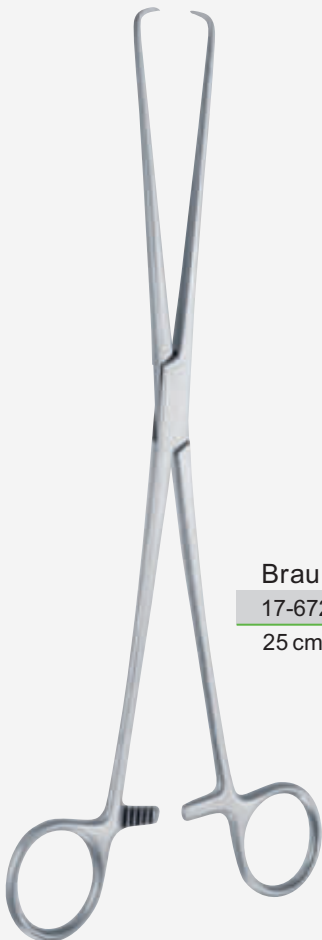

**Braun**  
17-672-25  
25 cm - 9 3/4"



**Pozzi**  
17-673-25  
25.5 cm - 10"

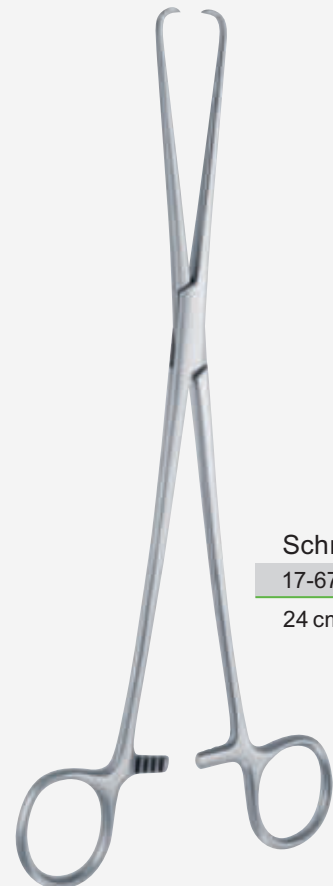

**Schroeder**  
17-674-24  
24 cm - 9 3/4"

Tenaculum forceps  
Hakenzangen  
Pinzas para coger el cuello del útero  
Pinces pour l'abaissement du col de l'utérus  
pinze Utenaculum

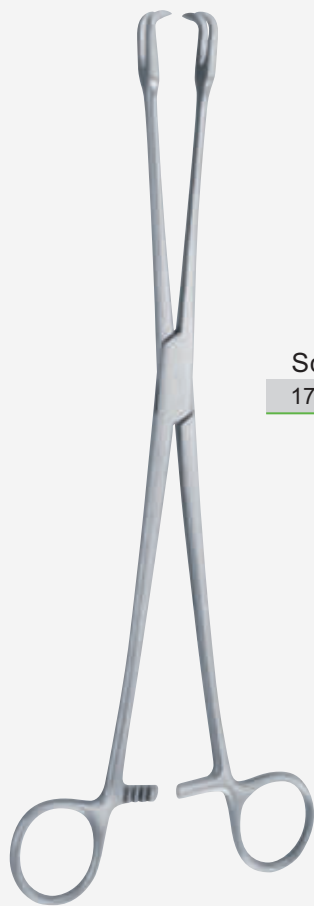

Schroeder  
17-675-24



17-676-24 24 cm - 9 1/2"



Duplay  
17-677-28  
28 cm - 11"





Iowa

17-678-26

26 cm - 10 ¼"



Beacham

17-679-26

26 cm - 10 ¼"

Amniotome  
Amniotom  
Amniotomo  
Amniotomo  
Amniotomo



Museux

17-680-01

17-680-02

17-680-03

24 cm - 9 ½"

17-681-01

17-681-02

17-681-03

24 cm - 9 ½"

8 mm

6 mm

10 mm

Tenaculum forceps  
Hakenzangen  
Pinzas para coger el cuello del útero  
Pinces pour l'abaissement du col de l'utérus  
pinze Utenaculum



Jacobs  
17-683-21    17-684-21    21 cm - 8 1/4"



Teale  
17-682-01  
230 mm - 9"



Pratt  
17-685-26    26 cm - 10 1/4"

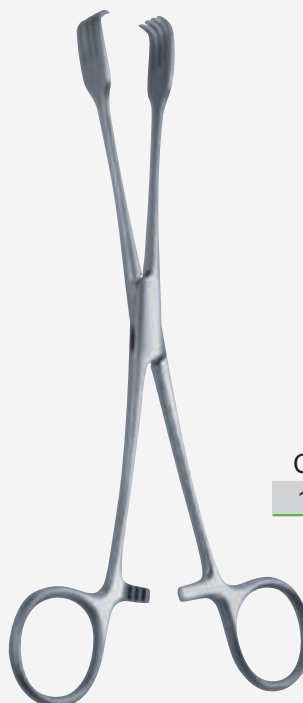

Czerny  
17-674-21    21 cm - 8"



Kelly

17-687-32 32 cm - 12 ½"



Noto

17-688-27 27 cm - 10 ¾"

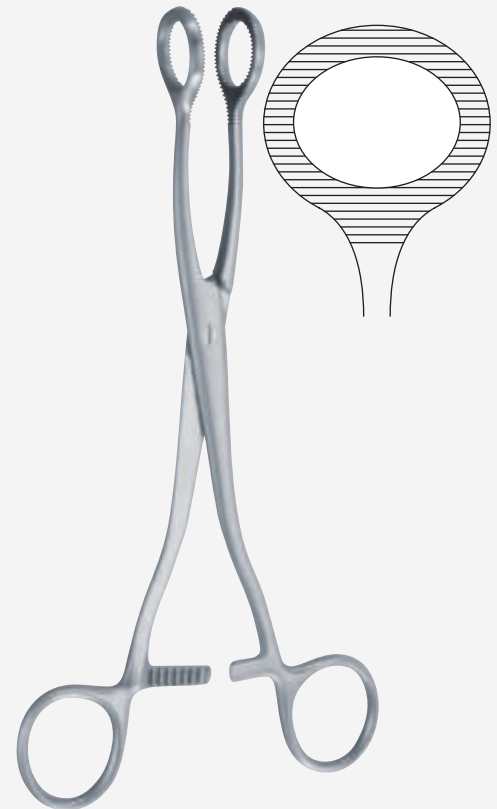

Doyen

17-689-20 20 cm - 8"

Uterine seizing forceps  
Uterusfazzangen  
Histerólabos  
Pincés hystérolabes  
Uterini cogliere forcipe

**comed**  
operate better with us



Dartigues

17-690-27 27 cm - 10 3/4"



Sommer

17-691-23 23 cm - 9"



Collin

17-692-25 25 cm - 9 3/4"

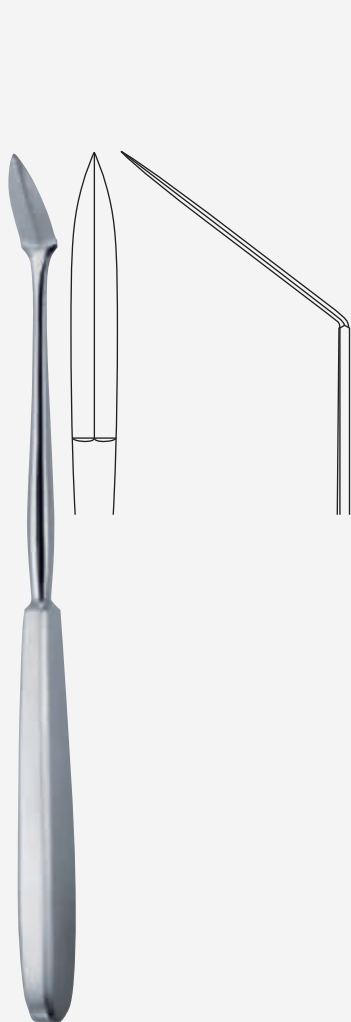

Ayre

17-693-23

23 cm - 9"



Segond

17-694-27

27 cm - 10 3/4"



Doyen

17-695-17

17 cm - 6 3/4"



Doyen

17-409-19

19 cm - 7 1/2"  
Ø 20 mm

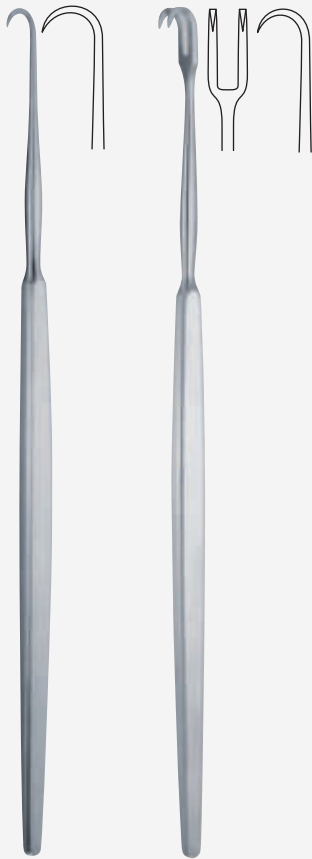

**Simon**  
 17-696-22    17-697-22    22 cm - 8 3/4"  
 Fig.1                      Fig.2



**Emmet**  
 17-698-22    17-699-22    22 cm - 8 3/4"  
 Fig.1                      Fig.2

**Emmet**  
 17-700-22    17-701-22    22 cm - 8 3/4"  
 Fig.3                      Fig.4

**Emmet**  
 17-702-22    22 cm - 8 3/4"  
 Fig.5



**Schubert**

17-703-21 21 cm - 8½"

17-703-28 28 cm - 11"



**Faure**

17-704-21 21 cm - 8 ½"



**Schubert**

17-705-26 26 cm - 10 ¼"

Cforceps specimen and biopsy cervical  
Probeexzisionszangen  
Pinzas saca-bocados para biopsia  
Pincas emporte-pièces à biopsie  
Cforceps campione e biopsia cervical

**comed**  
operate better with us



Gellhorn

17-706-23 23 cm - 9"



Thoms-Gaylor

17-707-22 22 cm - 8 3/4"

17-707-24 24 cm - 9 1/2"



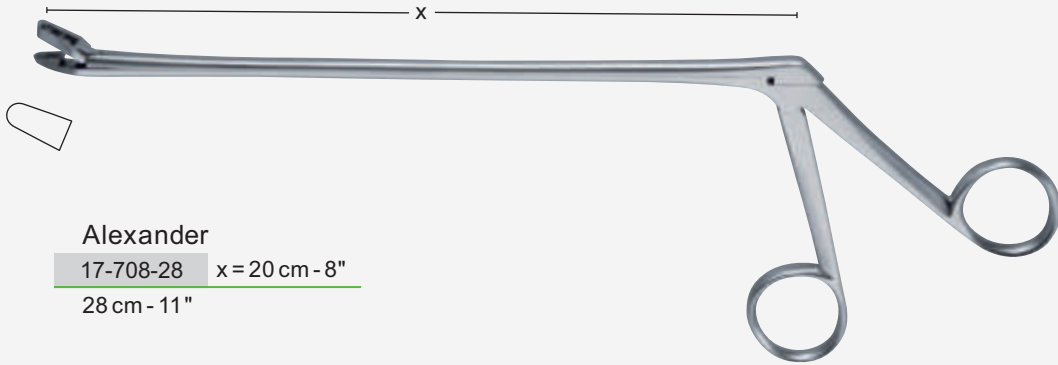

**Alexander**

17-708-28 x = 20 cm - 8"

28 cm - 11"

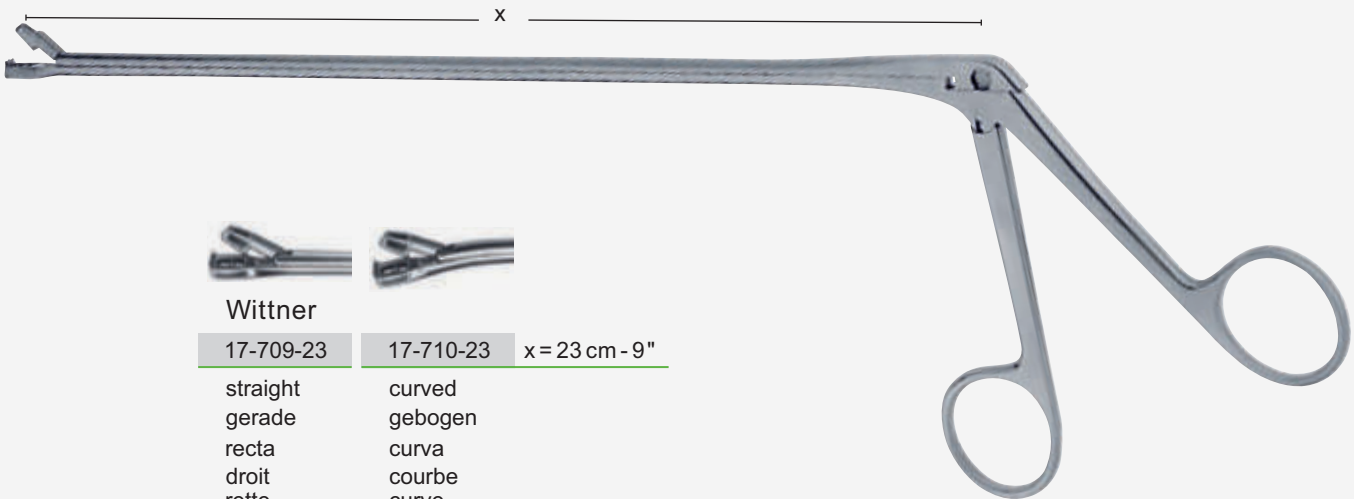

**Wittner**

17-709-23

17-710-23 x = 23 cm - 9"

straight  
gerade  
recta  
droit  
rette

curved  
gebogen  
curva  
courbe  
curve

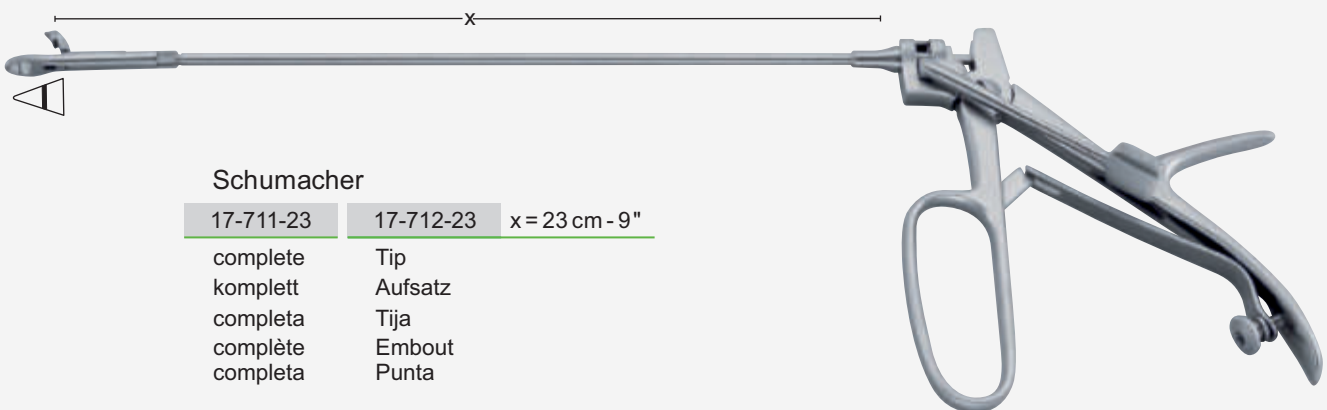

**Schumacher**

17-711-23

17-712-23 x = 23 cm - 9"

complete  
komplett  
completa  
complète  
completa

Tip  
Aufsatz  
Tija  
Embout  
Punta

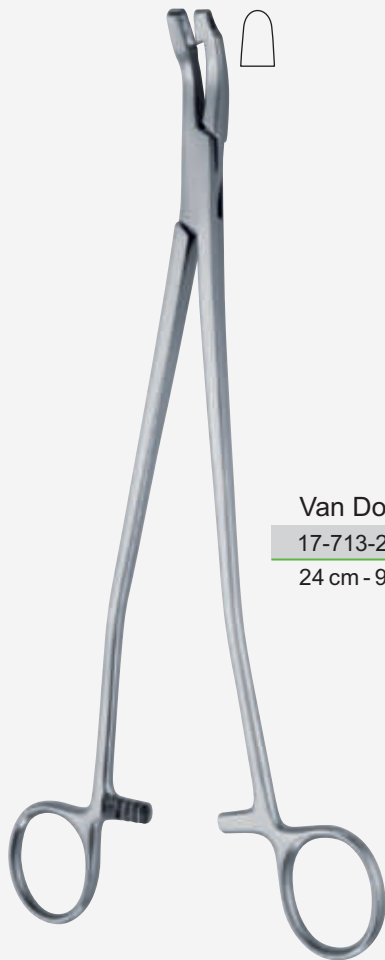

Van Doren  
 17-713-24  
 24 cm - 9½"



Schumacher  
 17-714-24  
 Fig.1

17-715-24 24 cm - 9½"  
 Fig.2

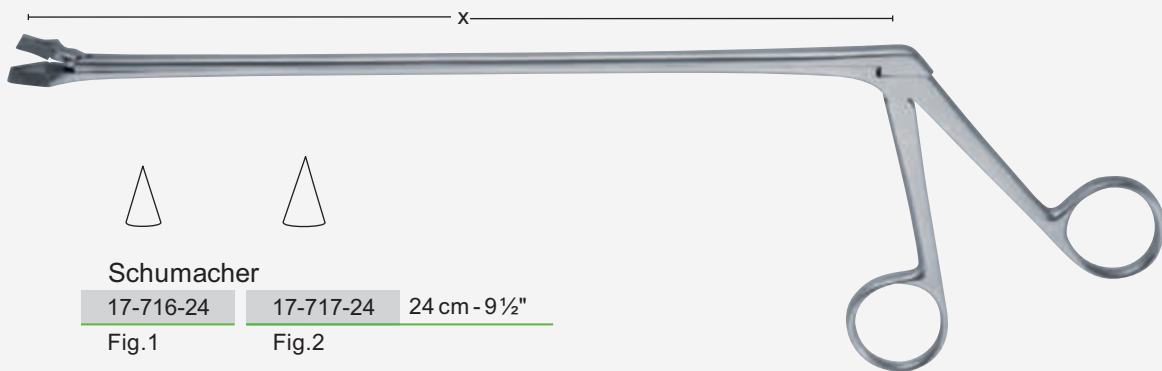

Schumacher

17-716-24 17-717-24 24 cm - 9½"

Fig.1

Fig.2

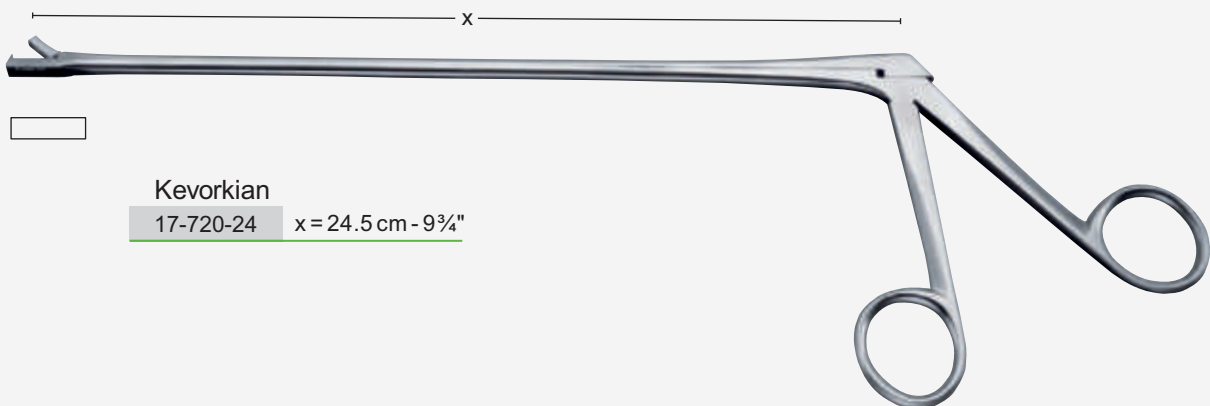
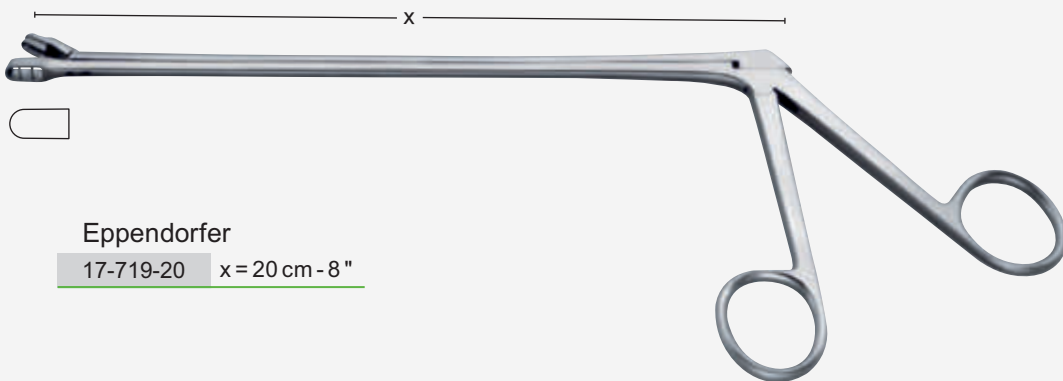
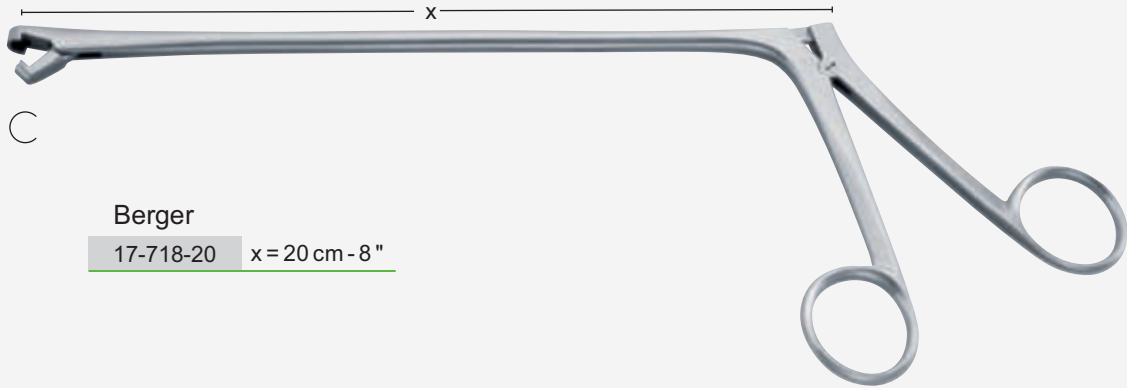

Cforceps specimen and biopsy cervical  
 Probeexzisionszangen  
 Pinzas saca-bocados para biopsia  
 Pincas emporte-pièces à biopsie  
 Cforceps campione e biopsia cervical

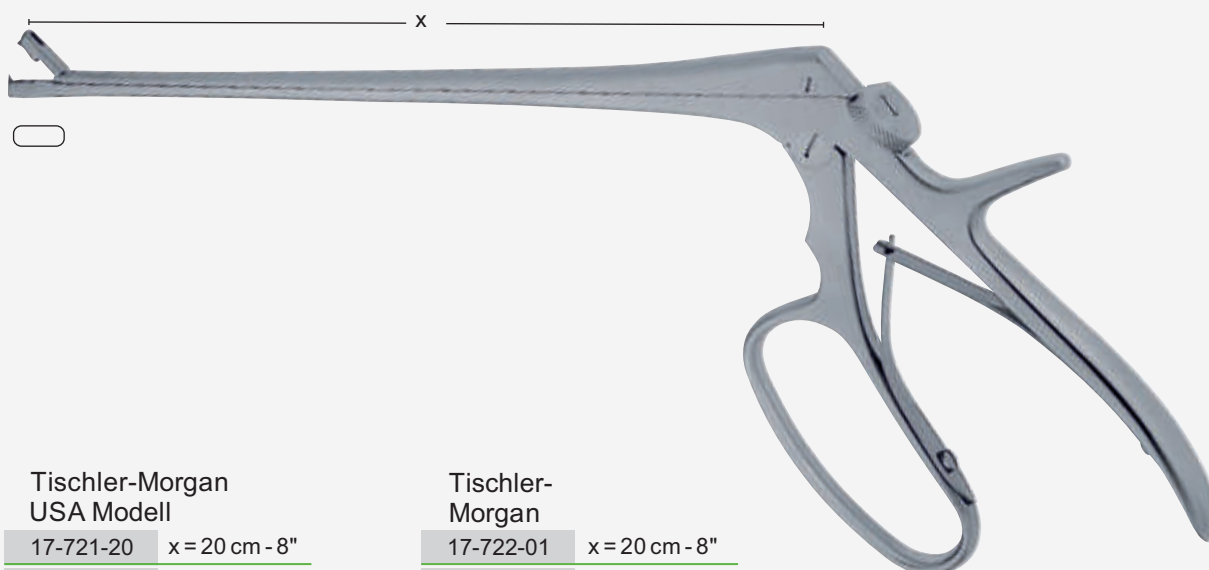

**Tischler-Morgan  
 USA Modell**

17-721-20	x = 20 cm - 8"
17-721-25	x = 25 cm - 9¾"

With locking screw  
 Mit Feststellschraube  
 Con tornillo de bloqueo  
 Avec vis de blocage  
 Con vite di bloccaggio

**Tischler-  
 Morgan**

17-722-01	x = 20 cm - 8"
17-722-02	x = 25 cm - 9¾"

Without locking screw  
 Ohne Feststellschraube  
 Sin tornillo de bloqueo  
 Sans vis de blocage  
 Senza vite di bloccaggio

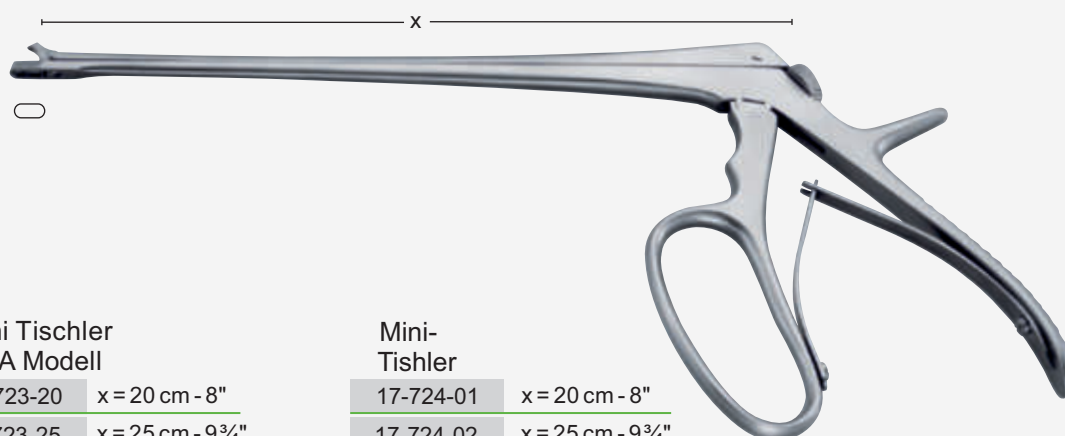

**Mini Tischler  
 USA Modell**

17-723-20	x = 20 cm - 8"
17-723-25	x = 25 cm - 9¾"

With locking screw  
 Mit Feststellschraube  
 Con tornillo de bloqueo  
 Avec vis de blocage  
 Con vite di bloccaggio

**Mini-  
 Tishler**

17-724-01	x = 20 cm - 8"
17-724-02	x = 25 cm - 9¾"

Without locking screw  
 Ohne Feststellschraube  
 Sin tornillo de bloqueo  
 Sans vis de blocage  
 Senza vite di bloccaggio



**Uni-Tischler**

17-725-00 3 x 7 mm

straight, Tip only  
gerade, Aufsatz allein  
recta, boca sola  
droit, mors seul  
retta, punta sola



**Standard**  
17-728-00

Handleonly  
Uni-Griff allein  
Mango solo  
Poignee seule  
Manico solo



**Uni-Tischler**

17-726-00 3 x 7 mm

up, Tip only  
aufwärts, Aufsatz allein  
arriba, boca sola  
haut, mors seul  
in alto, punta sola



**Uni-Tischler**

17-727-00 3 x 7 mm

down, Tip only  
abwärts, Aufsatz allein  
abajo, boca sola  
bas, mors seul  
in basso, punta sola



**Uni-Townsend**

17-729-00 2.3 x 4 mm

straight, Tip only  
gerade, Aufsatz allein  
recta, boca sola  
droit, mors seul  
retta, punta sola



**Uni-Townsend**

17-730-00 2.3 x 4 mm

up, Tip only  
aufwärts, Aufsatz allein  
arriba, boca sola  
haut, mors seul  
in alto, punta sola



**Grip**  
17-733-00

Uni-Griff allein mit Ring  
Handleonly  
Poignee seule  
Mango solo  
Manico solo



**Uni-Townsend**

17-731-00 2.3 x 4 mm

down, Tip only  
abwärts, Aufsatz allein  
abajo, boca sola  
bas, mors seul  
in basso, punta sola



**Uni-Townsend**

17-732-00 3 x 9 mm

Tip only  
Aufsatz allein  
Boca sola  
Mors seul  
Punta sola



**Uni-Oval**

17-734-00 2.3 x 4 mm

Tip only  
Aufsatz allein  
Boca sola  
Mors seul  
Punta sola



**Uni-Burke**

17-735-00 3 x 9 mm

Tip only  
Aufsatz allein  
Boca sola  
Mors seul  
Punta sola



**Randall**

17-736-24 24 cm - 9½"

4 mm Ø



**Kevorkian**

17-737-30

rigid, without basket  
 fest, ohne Korb  
 rigida, sin cesta  
 rigide, sans panier  
 rigida, senza cestino



17-738-30 30 cm - 12"

rigid, with basket  
 fest, mit Korb  
 rigida, con cesta  
 rigide, avec panier  
 rigida, con cestino

17-739-00

malleable, without basket  
 biegsam, ohne Korb  
 malleable, sin cesta  
 malléable, sans panier  
 flessibile, senza cestino

17-740-00

malleable, with basket  
 biegsam, mit Korb  
 malleable, con cesta  
 malléable, avec panier  
 flessibile, con cestino

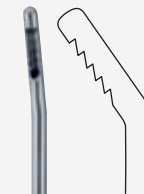

**Novak**

17-741-23 23 cm - 9"

4 mm Ø

**Mini-Novak**

17-742-01 1 mm Ø

17-742-02 2 mm Ø

17-742-03 3 mm Ø

23.5 cm - 9½"



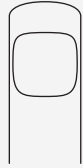

**Patera**

17-743-01	13 mm Ø
17-743-02	14 mm Ø
17-743-03	16 mm Ø
17-743-04	18 mm Ø
17-743-05	10 mm Ø
17-743-06	12 mm Ø
17-743-07	14 mm Ø

20 cm - 11 1/2"

Specimen and aspirating curette  
Probe- und Absaugkürette  
Cureta de biopsia y de aspiración  
Curette à biopsies et d'aspiration  
Curette per biopsia ed per aspirazione



**Lenardo**

17-730-04	4 mm Ø
17-730-06	6 mm Ø
17-730-08	8 mm Ø
17-730-10	10 mm Ø
17-730-12	12 mm Ø
17-730-14	14 mm Ø

28 cm - 11"



17-744-12	12 cm - 4 3/4"
-----------	----------------

Coupling piece  
Kupplungsstück  
Pieza de conexión  
Pièce d'accouplement  
Pezzo di connessione



**Schultze**

17-745-29 29.5 cm - 11 1/2"

Salpingograph, complete in woodencase  
 Salpingograph, komplett im Holzetui  
 Salpingógrafo, completa en caja de madera  
 Salpingographe, complet en etui de bois  
 Salpingografo, completo in astuccio di legno



**Remoson**

17-746-23 x= 23 cm - 9"

Forceps for I.U.D. removing  
 Zange zum Entfernen von Spiralen  
 Pinza para remover la espiral de esterilidad  
 Pince pour enlever des stérilets  
 Pinza per distaccare la spirale



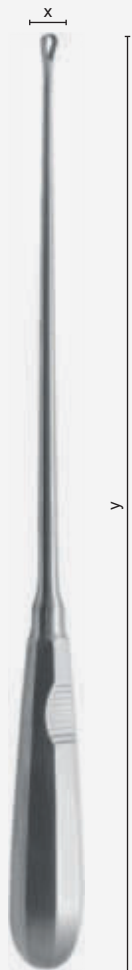
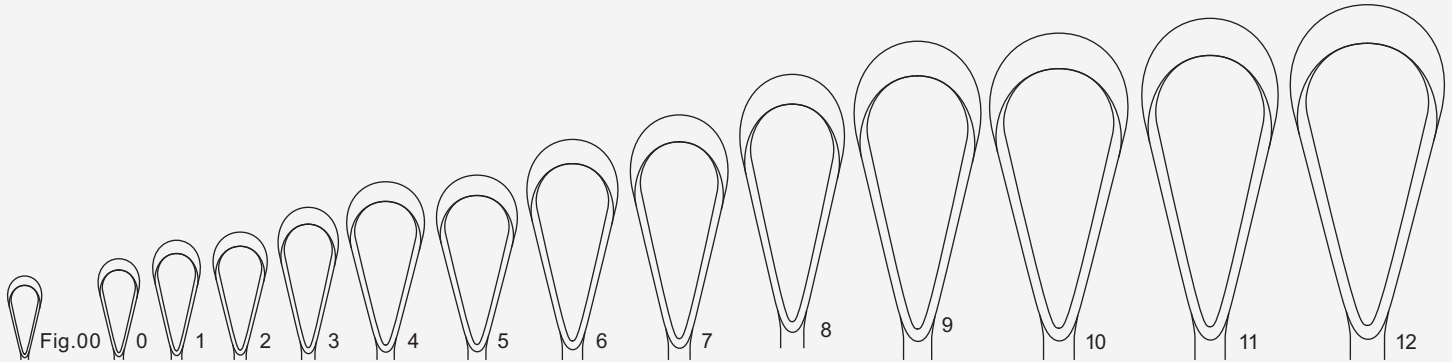

**Recamier**

17-747-01
17-747-02
17-747-03
17-747-04
17-747-05
17-747-06
17-747-07
17-747-08
17-747-09
17-747-10
17-747-11
17-747-12
17-747-13
17-747-14

y = 26 cm - 10 1/4"

17-748-01
17-748-02
17-748-03
17-748-04
17-748-05
17-748-06
17-748-07
17-748-08
17-748-09
17-748-10
17-748-11
17-748-12
17-748-13
17-748-14

17-749-01
17-749-02
17-749-03
17-749-04
17-749-05
17-749-06
17-749-07
17-749-08
17-749-09
17-749-10
17-749-11
17-749-12
17-749-13
17-749-14

	Fig.	x=mm
17-750-01	00	5
17-750-02	0	6
17-750-03	1	7
17-750-04	2	8
17-750-05	3	9
17-750-06	4	11
17-750-07	5	12
17-750-08	6	14
17-750-09	7	15
17-750-10	8	16
17-750-11	9	19
17-750-12	10	20
17-750-13	11	21
17-750-14	12	23

17-751-01
17-751-02
17-751-03
17-751-04
17-751-05
17-751-06
17-751-07
17-751-08
17-751-09
17-751-10
17-751-11
17-751-12
17-751-13
17-751-14

y = 31 cm - 12 1/4"

sharp, malleable  
scharf, biegsam  
cortante, maleable  
tranchante, malléable  
tagliente, flessibile

17-752-01
17-752-02
17-752-03
17-752-04
17-752-05
17-752-06
17-752-07
17-752-08
17-752-09
17-752-10
17-752-11
17-752-12
17-752-13
17-752-14

blunt, malleable  
stumpf, biegsam  
roma, maleable  
mousse, malléable  
smussa, flessibile

17-753-01
17-753-02
17-753-03
17-753-04
17-753-05
17-753-06
17-753-07
17-753-08
17-753-09
17-753-10
17-753-11
17-753-12
17-753-13
17-753-14

sharp, rigid  
scharf, fest  
cortante, rigida  
tranchante, rigide  
tagliente, rigida

	Fig.	x=mm
17-754-01	00	5
17-754-02	0	6
17-754-03	1	7
17-754-04	2	8
17-754-05	3	9
17-754-06	4	11
17-754-07	5	12
17-754-08	6	14
17-754-09	7	15
17-754-10	8	16
17-754-11	9	19
17-754-12	10	20
17-754-13	11	21
17-754-14	12	23

blunt, rigid  
stumpf, fest  
roma, rigida  
mousse, rigid  
smussa, rigida

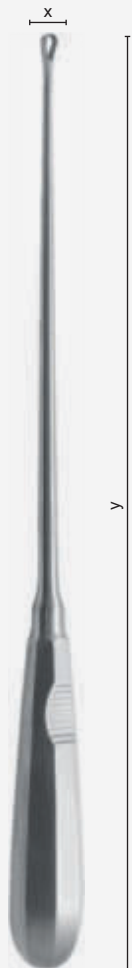
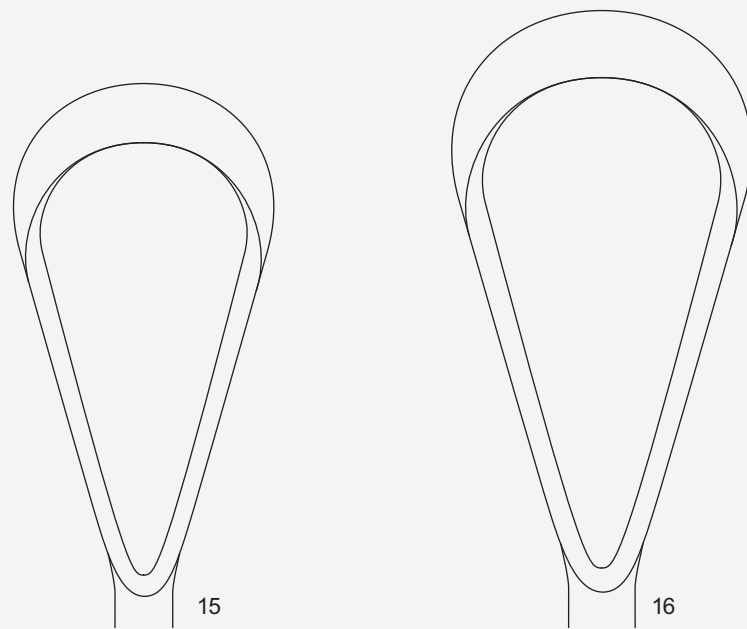
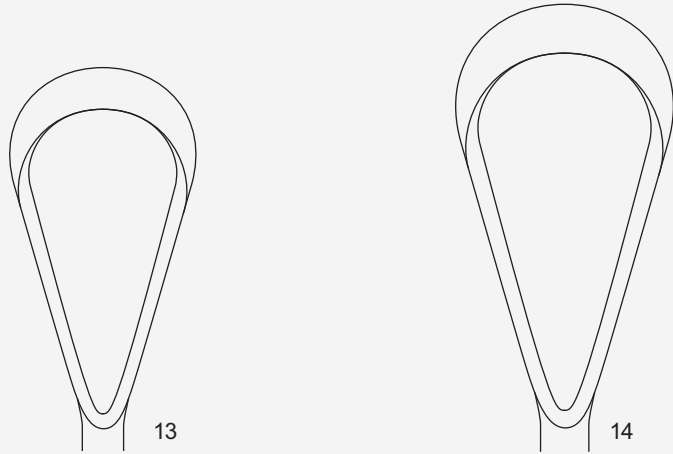

17-755-01
17-755-02
17-755-03
17-755-04

y = 34 cm - 13½"  
 sharp, malleable  
 scharf, biegsam  
 cortante, maleable  
 tranchante, malléable  
 tagliente, flessibile

17-756-01
17-756-02
17-756-03
17-756-04

blunt, malleable  
 stumpf, biegsam  
 roma, maleable  
 mousse, malléable  
 smussa, flessibile

17-757-01
17-757-02
17-757-03
17-757-04

sharp, rigid  
 scharf, fest  
 cortante, rigida  
 tranchante, rigide  
 tagliente, rigida

17-758-01
17-758-02
17-758-03
17-758-04

blunt, rigid  
 stumpf, fest  
 roma, rigida  
 mousse, rigid  
 smussa, rigida

Fig. x=mm

17-758-01	13	25
17-758-02	14	30
17-758-03	15	35
17-758-04	16	40



Fig. 1



Fig. 2



Fig. 3



Fig. 4



Fig. 5



Fig. 6

**Sims**

17-759-01
17-759-02
17-759-03
17-759-04
17-759-05
17-759-06

25 cm - 9¾"

sharp, malleable  
scharf, biegsam  
cortante, maleable  
tranchante, malléable  
tagliente, flessibile

17-760-01
17-760-02
17-760-03
17-760-04
17-760-05
17-760-06

blunt, malleable  
stumpf, biegsam  
roma, maleable  
mousse, malléable  
smussa, flessibile

17-761-01
17-761-02
17-761-03
17-761-04
17-761-05
17-761-06

sharp, rigid  
scharf, fest  
cortante, rigida  
tranchante, rigide  
tagliente, rigida

	Fig.	x=mm
17-762-01	1	7
17-762-02	2	8
17-762-03	3	9
17-762-04	4	11
17-762-05	5	12
17-762-06	6	14

blunt, rigid  
stumpf, fest  
roma, rigida  
mousse, rigid  
smussa, rigida



Simon

17-763-25

Fig.1



17-764-25

Fig.2



17-765-25

Fig.3

25 cm - 9¾"



17-766-00

Fig.4



17-767-00

Fig.5



17-768-00

Fig.6

sharp, rigid  
 scharf, fest  
 cortante, rigida  
 tranchante, rigide  
 taglienti, rigido



Schröder

17-769-30

Fig.1



17-770-30

Fig.2



17-771-30

Fig.3

30 cm - 12"



17-772-00

Fig.4



17-773-00

Fig.5



17-774-00

Fig.6

sharp, rigid  
 scharf, fest  
 cortante, rigida  
 tranchante, rigide  
 taglienti, rigido



Simpson

17-775-30 30 cm - 12"



Simpson-  
Braun

17-776-33 33 cm - 13"

17-776-36 36 cm - 14¼"



Naegele

17-777-36 36 cm - 14¼"

17-777-40 40 cm - 16"



Piper

17-778-44 44 cm - 17¼"



Simpson-  
Luikart

17-779-36 36 cm - 14 1/4"



Wrigley

17-780-25 25 cm - 9 3/4"

17-780-28 28 cm - 11"

for caesarian section  
für Kaiserschnitt  
para operación cesárea  
pour césarienne  
per taglio cesareo



DeLee

17-781-30 30 cm - 12"



DeLee

17-782-36 36 cm - 14 1/4"

17-782-39 39 cm - 15 1/2"



Elliot

17-783-32 32 cm - 12½"

17-783-38 38 cm - 15"



McLean

17-784-36 36 cm - 14¼"



Kielland

17-785-41 41 cm - 16¼"



Kielland-  
Luikart

17-786-40 40 cm - 16"

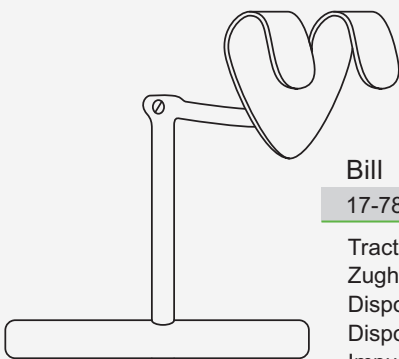

Bill

17-787-00

Traction handle for all the forceps with horned standard handle  
Zughebel, passend für alle Geburtszangen mit gehornem Standard-Griff  
Dispositivo de tracción para todos los forceps con mango standard cornudo  
Dispositif de traction pour tous les forceps avec manche normal à cornes  
Impugnatura di trazione adatto a tutti i forcipi con manico standard con corne



**Sellheim**

17-788-28 28 cm - 11"

Obstetric lever  
Geburtslöffel  
Cuchara obstétrica  
Cuillère obstétricale  
Cucchaio obstetrico



**Braun**

17-789-32 32.5 cm - 12 3/4"

Decapitating hook  
Dekapitationshaken  
Grancho de decapitación  
Crochet de décapitation  
Uncino di decapitazione



**Green-Armytage**

17-790-21 21 cm - 8 1/4" Str

17-790-00 21 cm - 8 1/4" Cvd

Uterine elevating forceps  
Uterusklemmzange  
Pinza para el útero  
Pince uterine  
Pinza uterina





**Smellie**

17-791-25 25 cm - 10"

Perforator  
Perforatorium  
Perforador  
Perforateur  
Perforatore



**Braun**

17-792-42 42 cm - 16½"

Cranioclast, one jaw fenestrated  
Kranioklast, ein Maul gefenstert  
Craneolasto, una boca fenestrada  
Cranioclaste, une partie fenestrée  
Cranioclaste, un lato fenestrato



**Tarnier**

17-793-46 46 cm - 17¼"

Basiotribe  
Basiotrib  
Basiotribo  
Basiotribe  
Basiotribo



**Winter**

17-794-28

17-795-28

17-796-28

28 cm - 11"

Fig.1  
 straight  
 gerade  
 recta  
 droit  
 retta

Fig.2

Fig.3

17-797-00

17-798-00

17-799-00

curved  
 gebogen  
 curva  
 courbe  
 curve

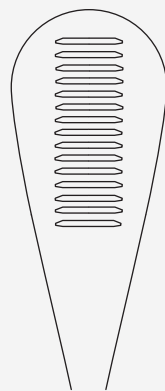

**Cuzzi**

17-800-30

17-801-30

17-802-30

30 cm - 12"

14.5 mm

18.0 mm

21.0 mm

blunt, back serrated  
 stumpf, Rückseite gerieft  
 romo, dorso estriado  
 mousse, dos strié  
 smusso, dorso zigrinato

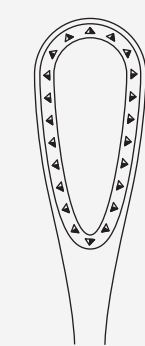

Saenger  
17-803-27

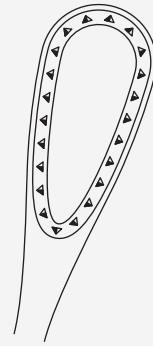

17-804-27 27 cm - 10¾"

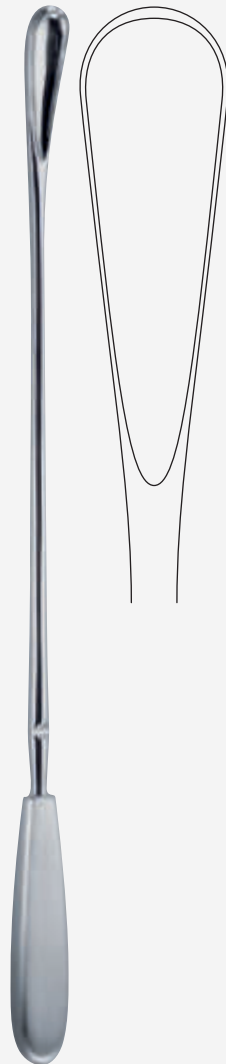

Wallich  
17-805-27 27 cm - 10¾"

blunt  
stumpf  
roma  
mousse  
smussa



Pestalozza  
17-806-30 30 cm - 12"

Umbilical cord clamps  
 Nabelschnurklemmen  
 Clamps umbilicales  
 Clamps pour le cordon ombilical  
 Morsetti del cordone ombelicale

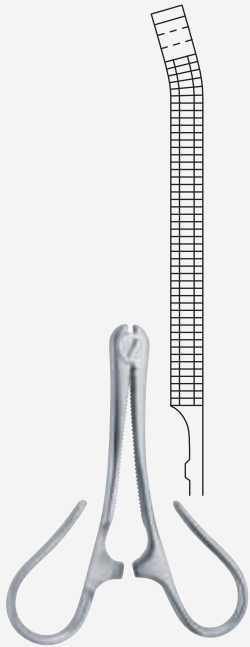

**Kane**  
 17-807-08 8.5 cm - 3 1/4"



**Collin**  
 17-808-09 9.0 cm - 3 1/2"



**Volkman Bone Curette**  
 17-811-01 Small  
 17-811-02 Medium  
 17-811-03 Large

Pelvimeters  
 Beckenzirkel  
 Pelvimetros  
 Pelvimètres  
 Pelvimeters

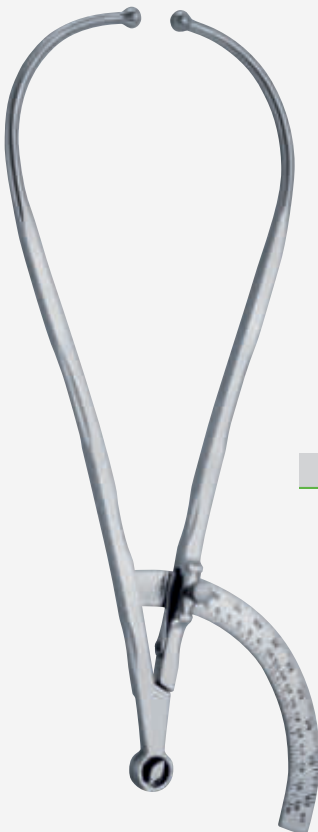

**Martin**  
 17-809-34 34 cm - 13 1/2"

cm / inch-scale  
 cm / Zoll-Scala  
 escala cm / pulgadas  
 échelle en cm / pouces  
 scala cm / pollici



**Collin**  
 17-810-35 35 cm - 13 3/4"

cm-scale  
 cm-Scala  
 escala en cm  
 échelle en cm  
 scala in cm







ENT  
HNO  
ORL  
ORL  
ORL

**comed**  
operate better with us

18



Toynbee				
				
<b>18-801-03</b>	<b>18-802-03</b>	<b>18-803-03</b>	<b>18-804-03</b>	<b>3.6 cm - 1 ½"</b>
Fig. 1 4.5 mm Ø	Fig. 2 5.5 mm Ø	Fig. 3 6.5 mm Ø	Fig. 4 7.5 mm Ø	
Set for adults Satz für Erwachsene Juego para adultos Jeu pour adultes Serie per adulti				
<b>18-801-00</b>	<b>Set of 4 pcs. Fig. 1 - 4</b>			



Richnau Holmgren			
			
<b>18-805-00</b>	<b>18-806-01</b>	<b>18-807-02</b>	<b>18-808-03</b>
Fig. 0 3 mm Ø	Fig. 1 4 mm Ø	Fig. 2 5 mm Ø	Fig. 3 6 mm Ø

 add "B" with catalogue part number if required in black TiN coating



**Gruber**

18-809-01

18-810-02

18-811-03

18-812-04

Fig. 1

Fig. 2

Fig. 3

Fig. 4

a = 4.5 mm Ø

a = 5.5 mm Ø

a = 6.5 mm Ø

a = 7.5 mm Ø

Set for adults

Satz für Erwachsene

Juego para adultos

Jeu pour adultes

Serie per adulti

18-809-00

Set of 4 pcs. Fig. 1 - 4



**Gruber**

18-813-01

18-814-02

18-815-03

18-816-04

Fig. 1

Fig. 2

Fig. 3

Fig. 4

a = 4.5 mm Ø

a = 5.5 mm Ø

a = 6.5 mm Ø

a = 7.5 mm Ø

Set for adults

Satz für Erwachsene

Juego para adultos

Jeu pour adultes

Serie per adulti

18-813-00

Set of 4 pcs. Fig. 1 - 4



**Zöllner**

18-817-01

18-818-02

18-819-03

18-820-04

18-821-05

18-822-06

Fig. 1

Fig. 2

Fig. 3

Fig. 4

Fig. 5

Fig. 6

5.5 x 6.5 mm

6.5 x 7.5 mm

7.5 x 8.5 mm

8.5 x 9.5 mm

9.5 x 10.5 mm

10.5 x 11.5 mm

Set for adults, black

Satz für Erwachsene, schwarz

Juego para adultos, negro

Jeu pour adultes, noir

Serie per adulti, nero

18-817-00

Set of 6 pcs. Fig. 1 - 6



**Politzer**

18-823-01

18-824-02

18-825-03

18-826-04

Fig. 1

Fig. 2

Fig. 3

Fig. 4

2 mm Ø

3 mm Ø

4 mm Ø

5 mm Ø

Set for adults

Satz für Erwachsene

Juego para adultos

Jeu pour adultes

Serie per adulti

18-823-00

Set of 4 pcs. Fig. 1 - 4

 add "B" with catalogue part number if required in black TiN coating



<b>Boucheron</b>				
<b>18-827-01</b>	<b>18-828-02</b>	<b>18-829-03</b>	<b>18-830-04</b>	<b>18-827-00</b>
Fig. 1 4.5 mm Ø	Fig. 2 5.5 mm Ø	Fig. 3 6.5 mm Ø	Fig. 4 7.5 mm Ø	Set of 4 pcs. Fig. 1 - 4
Set for adults Satz für Erwachsene Juego para adultos Jeu pour adultes Serie per adulti				



<b>Boucheron</b>			
<b>18-831-00</b>	<b>18-832-01</b>	<b>18-833-02</b>	<b>18-831-00</b>
Fig. 0 3.0 mm Ø	Fig. 1 4.5 mm Ø	Fig. 2 5.5 mm Ø	Set of 3 pcs. Fig. 0 - 2
Set for children Satz für Kinder Juego para niños Jeu pour enfants Serie per bambini			



<b>Hartmann</b>				
<b>18-834-01</b>	<b>18-835-02</b>	<b>18-836-03</b>	<b>18-837-04</b>	<b>18-834-00</b>
Fig. 1 4.5 mm Ø	Fig. 2 5.5 mm Ø	Fig. 3 6.5 mm Ø	Fig. 4 7.5 mm Ø	Set of 4 pcs. Fig. 1 - 4
Set for adults Satz für Erwachsene Juego para adultos Jeu pour adultes Serie per adulti				



<b>Hartmann</b>				
<b>18-838-01</b>	<b>18-839-02</b>	<b>18-840-03</b>	<b>18-841-04</b>	<b>18-842-05</b>
Fig. 1 2.0 mm Ø	Fig. 2 3.5 mm Ø	Fig. 3 5.0 mm Ø	Fig. 4 6.5 mm Ø	Fig. 5 7.5 mm Ø
Set for adults, black Satz für Erwachsene, schwarz Juego para adultos, negro Jeu pour adultes, noir Serie per adulti, nero			<b>18-838-00</b> Set of 5 pcs. Fig. 1 - 5	



<b>Tumarkin</b>				
<b>18-127-00</b>	<b>18-127-01</b>	<b>18-127-02</b>	<b>18-127-03</b>	<b>18-127-04</b>
Fig. 0	Fig. 1	Fig. 2	Fig. 3	Fig. 4
<b>18-127-05</b>	<b>18-127-06</b>	<b>18-127-07</b>	<b>18-127-08</b>	
Fig. 5	Fig. 6	Fig. 7	Set of 8 for adults. Fig. 0 - 7	

add "B" with catalogue part number if required in black TiN coating





Siegle

18-843-00

Fig. 1  
6.5 mm Ø

Setcomplete  
Satz komplett  
Juego completo  
Jeu complet  
Serie completa



18-844-01

Fig. 2  
7.0 mm Ø



18-845-02

Fig. 3  
8.0 mm Ø

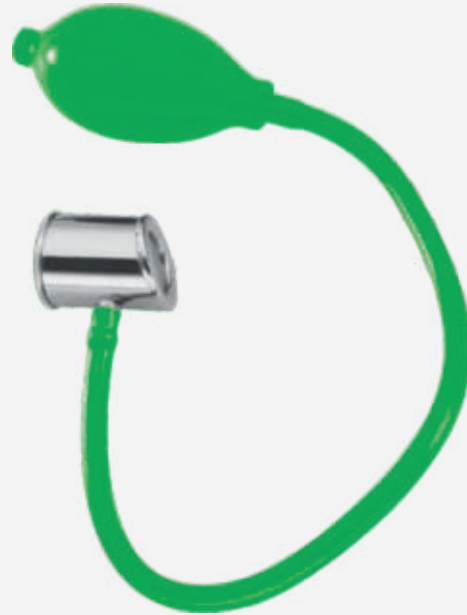

18-846-00

Magnifyer, alone  
Lupenkörper, allein  
Lupa, sola  
Loupe, seule  
Lente, solo



Bruenings

18-847-00

Fig. 1  
6.5 mm Ø

Setcomplete  
Satz komplett  
Juego completo  
Jeu complet  
Serie completa



18-848-01

Fig. 2  
7.5 mm Ø



18-849-02

Fig. 3  
8.5 mm Ø



18-850-01

Fig. 4  
9.5 mm Ø

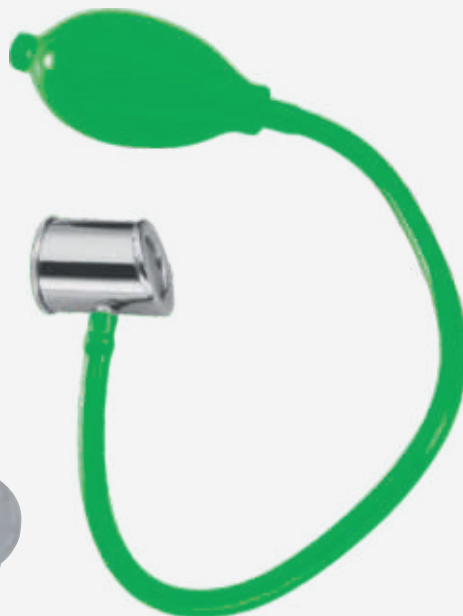

18-851-00

Magnifyer, alone  
Lupenkörper, allein  
Lupa, sola  
Loupe, seule  
Lente, solo



Lucae  
18-852-00

c 128  
variable up to h (engl. b)  
verschiebbar bis h  
variable hasta h (esp. si)  
variable jusqu'à h (franc. si)  
regolabile fino a h



Rydel-Seiffer  
18-853-00

C 64 / c 128

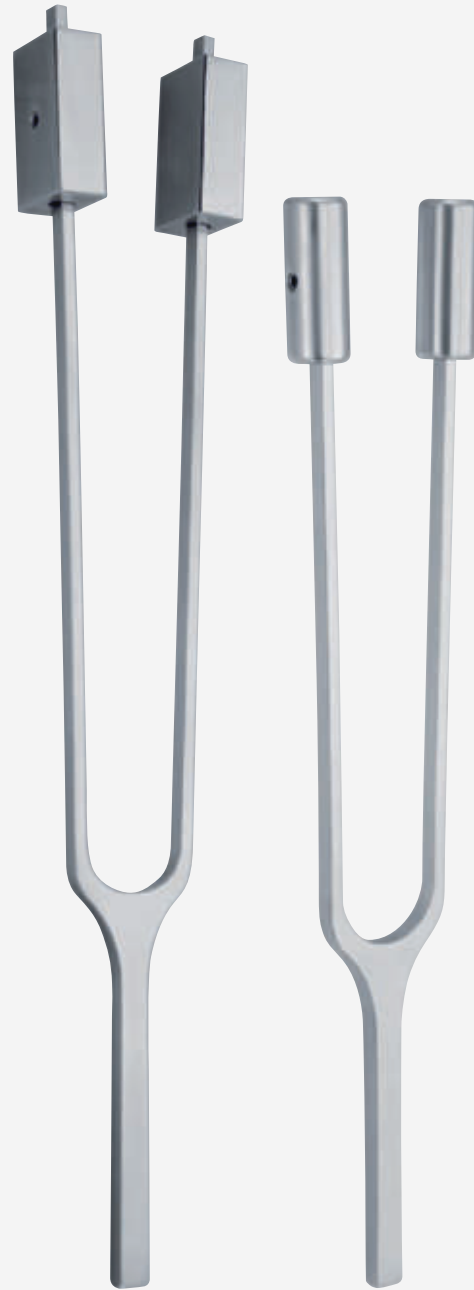

French  
18-854-00

C<sub>2</sub> 16  
with clamps C 64, without clamps c 128  
mit Dämpfer C64, ohne Dämpfer c128  
con sordinas C 64, sin sordinas c128  
avec curseurs C 64, sans curseurs c128  
con cursori C 64, senza cursori c128

18-855-00

C<sub>1</sub> 32



Hartmann

18-856-00

C 64

18-857-00

c 128

18-858-00

c' 256

18-859-00

a' 440

Noise drum  
Lärmtrommel  
Aparato de ruido  
Assourdisseur  
Assordatore



Barany

18-860-00



Hartmann

18-861-00

c 128

18-862-00

c<sup>1</sup> 256

18-863-00

c<sup>2</sup> 512

18-864-00

c<sup>3</sup> 1024

18-865-00

c<sup>4</sup> 2048

18-866-00

c<sup>5</sup> 4096



Hartmann

18-867-00 Set of 5 pcs consisting:

18-857-00 c 128

18-858-00 c<sup>1</sup> 256

18-863-00 c<sup>2</sup> 512

18-864-00 c<sup>3</sup> 1024

18-865-00 c<sup>4</sup> 2048



18-868-00	18-869-00	18-870-00	18-871-00	18-872-00
c 128	c <sup>1</sup> 256	c <sup>2</sup> 512	c <sup>3</sup> 1024	c <sup>4</sup> 2048



18-873-00	Set of 5 pcs consisting:
18-868-00	c 128
18-869-00	c <sup>1</sup> 256
18-870-00	c <sup>2</sup> 512
18-871-00	c <sup>3</sup> 1024
18-872-00	c <sup>4</sup> 2048

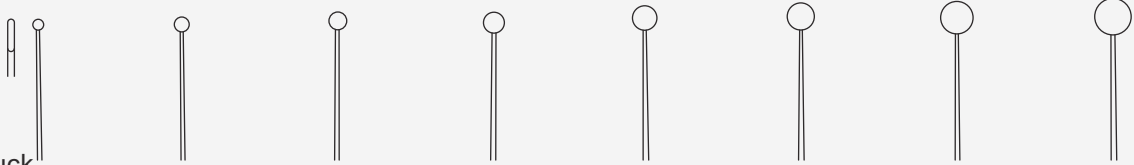

**Buck**

18-874-16	18-875-16	18-876-16	18-877-16	18-878-16	18-879-16	18-880-16	18-881-16	16.5 cm - 6 ½"
Fig. 000	Fig. 00	Fig. 0	Fig. 1	Fig. 2	Fig. 3	Fig. 4	Fig. 5	
blunt stumpf roma mousse smussa								

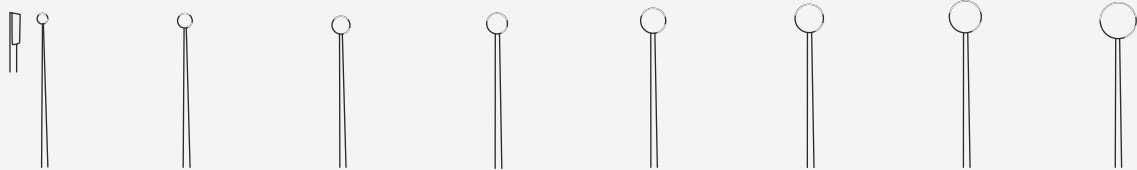

**Buck**

18-882-16	18-883-16	18-884-16	18-885-16	18-886-16	18-887-16	18-888-16	18-889-16	16.5 cm - 6 ¾"
Fig. 000	Fig. 00	Fig. 0	Fig. 1	Fig. 2	Fig. 3	Fig. 4	Fig. 5	
sharp scharf cortante tranchante tagliente								

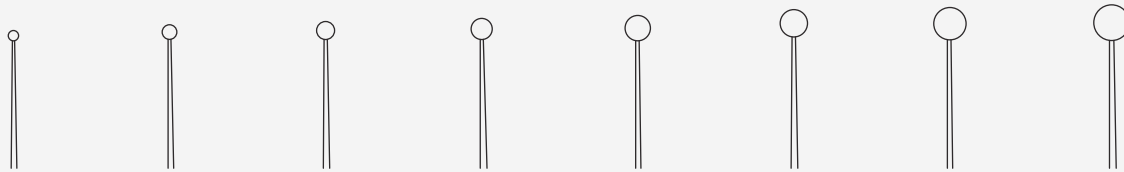

**Buck**

18-890-16	18-891-16	18-892-16	18-893-16	18-894-16	18-895-16	18-896-16	18-897-16	16.5 cm - 6 1/2"
-----------	-----------	-----------	-----------	-----------	-----------	-----------	-----------	------------------

Fig. 000	Fig. 00	Fig. 0	Fig. 1	Fig. 2	Fig. 3	Fig. 4	Fig. 5	
----------	---------	--------	--------	--------	--------	--------	--------	--

curved, blunt  
gebogen, stumpf  
curva, cortante  
courbe, tranchante  
curva, smussa

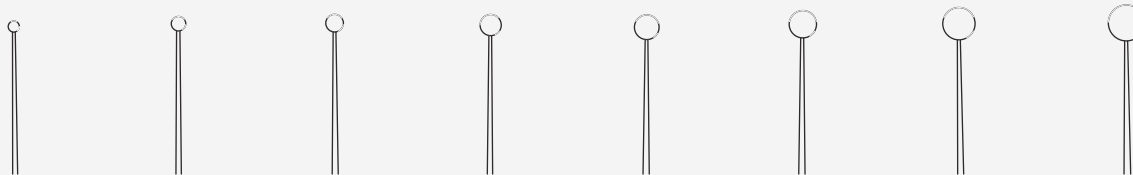

**Buck**

18-898-16	18-899-16	18-900-16	18-901-16	18-902-16	18-903-16	18-904-16	18-905-16	16.5 cm - 6 1/2"
-----------	-----------	-----------	-----------	-----------	-----------	-----------	-----------	------------------

Fig. 000	Fig. 00	Fig. 0	Fig. 1	Fig. 2	Fig. 3	Fig. 4	Fig. 5	
----------	---------	--------	--------	--------	--------	--------	--------	--

curved sharp  
gebogen, scharf  
curva, aguda  
courbe, pointue  
curva, tagliente

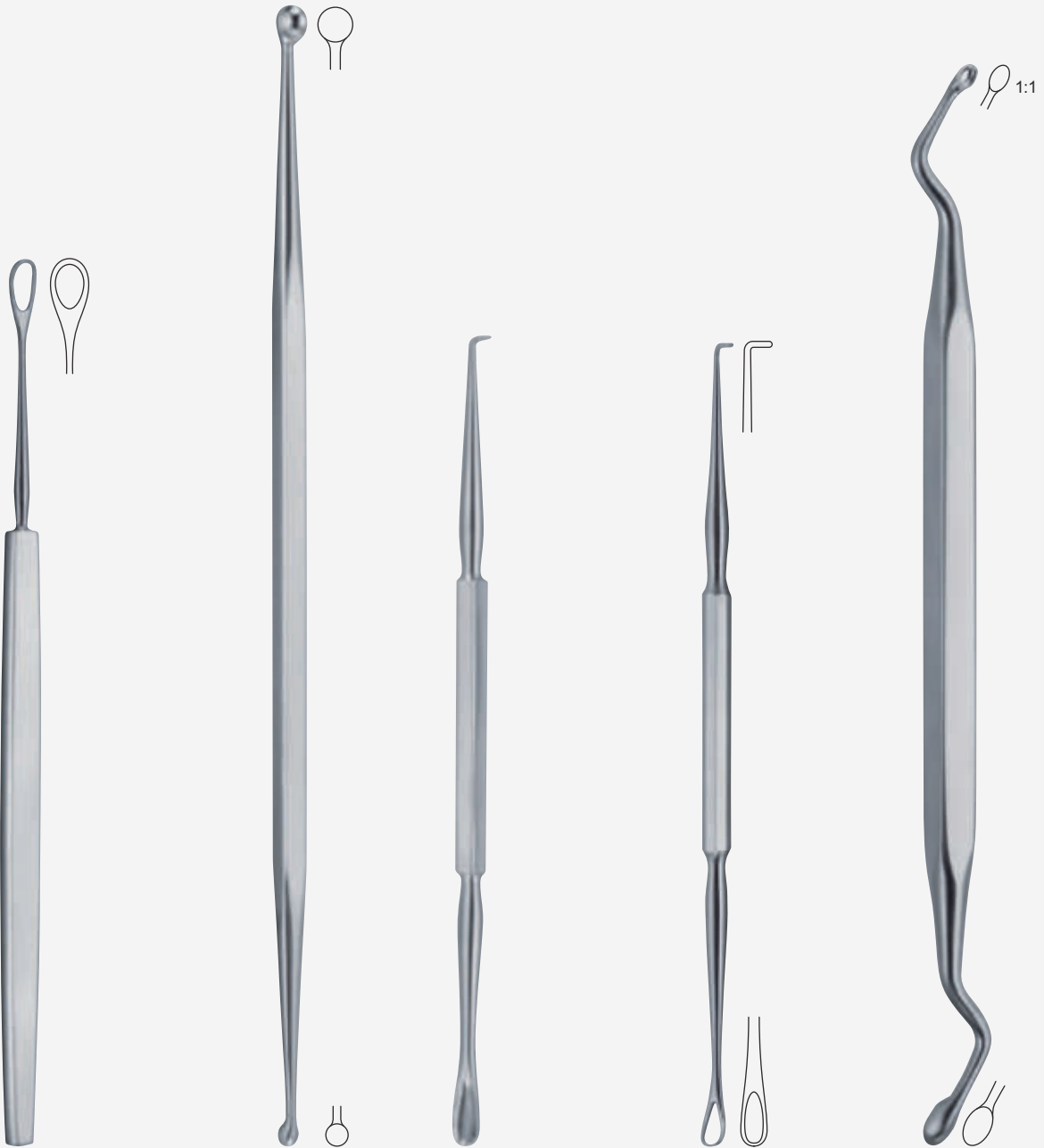

**Langenbeck**

18-906-13

13 cm - 5"

blunt

stumpf

roma

mousse

smussa

**Jansen**

18-907-17

17 cm - 6 3/4"

sharp

scharf

cortante

tranchante

acuta

**Gross**

18-908-12

12 cm - 4 3/4"

sharp, not fenestrated

scharf, voll

cortante, lleno

tranchante, pleine

acuta, pieno

**Macal**

18-909-12

12 cm - 4 3/4"

blunt, fenestrated

stumpf, gefenstert

romas, fenestrada

mousse, fenêtrée

smussa, fenestrata

**Jansen**

18-910-16

16 cm - 6 1/4"

sharp

scharf

cortante

tranchante

acuta





Billeau

18-911-16



18-912-16



18-913-16

16.5 cm - 6 1/2"



Lucae

18-914-14



18-915-14



18-916-14

14 cm - 5 1/2"



Wagener

18-917-14



18-918-14



18-919-14



18-920-14



18-921-14



18-922-14



18-923-14

14 cm - 6 1/2"

Ear hooks – knives  
Ohrhäkchen – Messer  
Ganchos – cuchillos auriculares  
Crochets – couteaux auriculaires  
Ganci per le orecchie - coltelli

**comed**  
operate better with us



Day

18-924-16

18-925-16

16 cm - 6 ¼"



Muck

18-926-13

13.5 cm - 5 ¼"



Gerzog-Sexton

18-927-17

17 cm - 6 ¾"



**Politzer**  
18-928-16  
15 cm - 6"



**Gerzog**  
18-929-16  
16 cm - 6 ¼"



**Buck**  
18-930-16  
16 cm - 6 ¼"



**Lucae**  
18-931-18



18-932-18 18 cm - 7"



**Lucae**  
18-933-19  
19 cm - 7 ½"



**Politzer**  
18-934-17  
17 cm - 6 ¾"



**Politzer**  
18-935-16  
16 cm - 6 ¼"  
Needle vertical  
Nadel senkrecht  
Aguja vertical  
Aiguille verticale  
Ago verticale



18-936-16  
16 cm - 6 ¼"  
Needle horizontal  
Nadel waagrecht  
Aguja horizontal  
Aiguille horizontale  
Ago orizzontale



**Littauer**  
 18-942-12 16.5 cm - 6 3/4"



**Hartmann**  
 18-943-12 16.5 cm - 6 3/4"

delicate jaw  
 feines Modell  
 modelo fino  
 modèle fin  
 modello fino



**Hartmann**  
 18-944-14 14 cm - 5 3/4"

normal jaw  
 normales Modell  
 modelo estandar  
 modèle standard  
 modello standard



**Quire**  
 18-945-10 10.5 cm - 4 1/4"

Foreign body lever  
 Fremdkörperhebel  
 Elevador para cuerpos extraños  
 Levier pour corps étrangers  
 Leva per corpi estranei



**Buck**  
 18-946-11 11.5 cm - 4 1/4"

Foreign body forceps  
 Fremdkörperzängchen  
 Pinza para cuerpos extraños  
 Pince pour corps étrangers  
 Pinza per corpi estranei

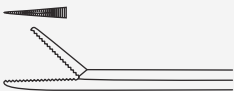

**Hartmann-Wullstein**

18-947-08 x = 8.5 cm - 3 1/4"



**Hartmann-Wullstein**

18-948-08 x = 8.5 cm - 3 1/4"

1 mm Ø



**Hartmann**

18-949-01 x = 8.5 cm - 3 1/4"

18-949-02 x = 14 cm - 5 1/4"

18-949-03 x = 16 cm - 6 1/4"

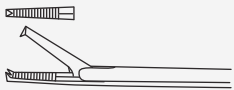

**Hartmann**

18-950-08 x = 8.5 cm - 3 1/4"

18-950-14 x = 14 cm - 5 1/2"

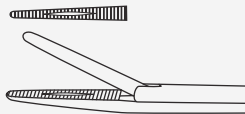

**Hartmann-Noyes**

18-951-09 x = 9 cm - 3 1/2"

1 mm Ø



**Struempel**

18-952-08 0°  
x = 8.5 cm - 3 1/4"



18-953-08 45°



18-954-08 90°



**Hartmann-Weingärtner**

18-955-08 x = 8.5 cm - 3 1/4"



**Hartmann**

18-956-01 2.0 mm Ø

18-956-02 2.5 mm Ø

18-956-03 3.0 mm Ø

x = 8.5 cm - 3 1/4"



**McGee**

18-957-00 3.5 mm x 0.8 mm

Wirebending forceps  
 Drahtbiegezängchen  
 Pinza para plegar alambres  
 Pince pour plier fils métalliques  
 Pinza per piegare fili metallici

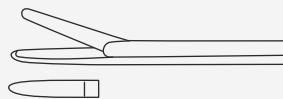

**Fuller**

18-958-08 8 cm - 3 1/4"

Introducing forceps for teflon prosthesis  
 Einführungszängchen für Teflonprothesen  
 Pinza para introducir para prótesis de teflon  
 Pince pour introduction pour prothèses de téflon  
 Pinza per introduzione di protesi in teflon

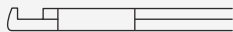

**Dieter**

18-959-08

up-cutting  
 oben schneidend  
 corte arriba  
 coupe en haut  
 tagliente in alto



18-960-08

down-cutting  
 unten schneidend  
 corte abajo  
 coupe en bas  
 tagliente in basso

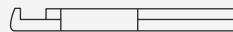

18-961-08

right-cutting  
 rechts schneidend  
 corte derecha  
 coupe à droite  
 tagliente a destra



18-962-08 x = 8 cm - 3 1/4"

left-cutting  
 links schneidend  
 corte izquierda  
 coupe à gauche  
 tagliente a sinistra

Malleus nipper  
 Hammerkopfzängchen  
 Pinza para cabezal del martillo  
 Pince pour l'os marteau  
 Pinza per testa del martelletto

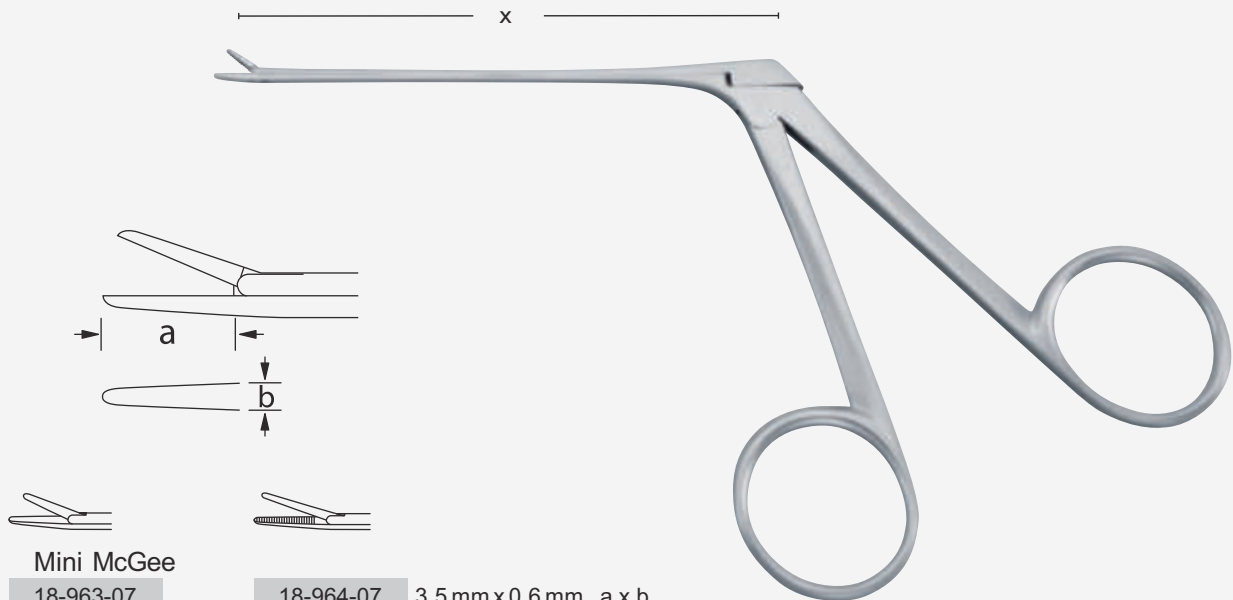

**Mini McGee**

**18-963-07**

x = 75 mm - 3"

straight, smooth  
gerade, glatt  
recta, lisa  
droit, lisse  
retta, liscia

**18-964-07** 3.5 mm x 0.6 mm a x b

x = 75 mm - 3"

straight, serrated  
gerade, gerieft  
recta, estriada  
droit, strié  
retta, zigrinata



**18-965-07**

x = 75 mm - 3"

straight, smooth  
gerade, glatt  
recta, lisa  
droit, lisse  
retta, liscia

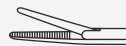

**18-966-07**

x = 75 mm - 3"

straight, serrated  
gerade, gerieft  
recta, estriada  
droit, strié  
retta, zigrinata



**18-967-01** 3.5 mm 0.6 mm a x b

**18-867-02** 4.0 mm 0.8 mm a x b

x = 75 mm - 3"

curved upwards, serrated  
aufgebogen, gerieft  
curvada arriba, estriada  
coudé en haut, strié  
curvata in alto, zigrinata



**18-967-03**

**18-967-04**

x = 75 mm - 3"

curved to right, serrated  
rechts gebogen, gerieft  
curvada a la derecha, estriada  
coudé à droite, strié  
curvata a desrta, zigrinata



**18-967-05**

**18-967-06**

x = 75 mm - 3"

curved to left, serrated  
linksgebogen, gerieft  
curvada a la izquierda, estriada  
coudé à gauche, strié  
curvata a shistra, zigrinata



**18-967-07** 3.5 mm x 0.6 mm a x b

**18-967-08** 4.0 mm x 0.8 mm a x b

x = 75 mm - 3"

angled down, serrated  
abwärts gebogen, gerieft  
curvada à bajo, estriada  
coudé en bas, strié  
curvata in basso zigrinata



Nikki

18-968-07

x = 75 mm - 3"

straight, oval  
 gerade, oval  
 recta, oval  
 droit, ovale  
 retta, ovale



18-969-07

x = 75 mm - 3"

curved upwards, oval  
 aufgebogen, oval  
 curvada arriba, oval  
 coudé en haut, ovale  
 curvata in alto, ovale



18-970-07

x = 75 mm - 3"

curved to left, oval  
 links gebogen, oval  
 curvada a la izquierda, oval  
 coudé à gauche, ovale  
 curvata a sinistra, ovale

a = 4.0 mm  
 b = 1.0 mm x c = 0.9 mm



18-971-07

x = 75 mm - 3"

curved to right, oval  
 rechts gebogen, oval  
 curvada a la derecha, oval  
 coudé à droite, ovale  
 curvata a destra, ovale



18-972-07

x = 75 mm - 3"

curved downwards, oval  
 abwärts gebogen, oval  
 curvada a bajo, oval  
 coudé en bas, ovale  
 curvata in basso, ovale



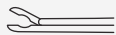
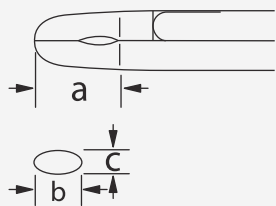

Cobson

18-973-01

18-973-02

x = 8 cm - 3 1/4"

straight, oval  
gerade, oval  
recta, oval  
droit, ovale  
retta, ovale



18-974-01 a = 3.5 mm  
b = 0.6 mm x c = 0.5 mm

18-974-02 a = 4.0 mm  
b = 1.0 mm x c = 0.9 mm

curved upwards, oval  
aufgebogen, oval  
curvada arriba, oval  
coudé en haut, ovale  
curvata in alto, ovale

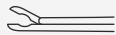

18-975-01

18-975-02

x = 8 cm - 3 1/4"

curved to right, oval  
rechts gebogen, oval  
curvada a la derecha, oval  
coudé à droite, ovale  
curvata a destra, ovale



18-976-01 a = 3.5 mm  
b = 0.6 mm x c = 0.5 mm

18-976-02 a = 4.0 mm  
b = 1.0 mm x c = 0.9 mm

curved to left, oval  
aufgebogen, oval  
curvada arriba, oval  
coudé à gauche, ovale  
curvata in alto



**Belucci**

**18-977-07**

x = 7.5 cm - 3"  
 straight, sharp/sharp  
 gerade, spitz/spitz  
 recta, aguda/aguda  
 droit, pointue/pointue  
 retta, acuta/acuta

very fine  
 sehr fein  
 muy fina  
 très fine  
 molto delicata



**18-978-07** 4.0 mm x 0.8 mm

x = 7.5 cm - 3"  
 curved upwards, blunt/blunt  
 aufgebogen, stumpf/stumpf  
 curvada arriba, roma/roma  
 courbées en haut, mousse/mousse  
 curvata in alto, smussa/smussa



**Belucci**

**18-979-07**

x = 7.5 cm - 3"  
 a x b  
 curved to right, sharp/sharp  
 rechts gebogen, spitz/spitz  
 curvada a la derecha, aguda/aguda  
 coudé à droite, pointue/pointue  
 curvata a destra, acuta/acuta

very fine  
 sehr fein  
 muy fina  
 très fine  
 molto delicata



**18-980-07** 4.0 mm x 0.8 mm

x = 7.5 cm - 3"  
 curved to left, sharp/sharp  
 links gebogen, spitz/spitz  
 curvada a la izquierda, aguda/aguda  
 coudée à gauche, pointue/pointue  
 curvata a sinistra, acuta/acuta



**18-981-07** 4.0 mm x 0.8 mm

x = 7.5 cm - 3"  
 straight, sharp/blunt  
 gerade, spitz/stumpf  
 recta, aguda/roma  
 droit, pointue/mousse  
 retta, acuta/smussa

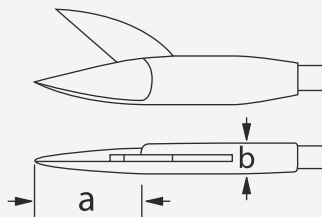
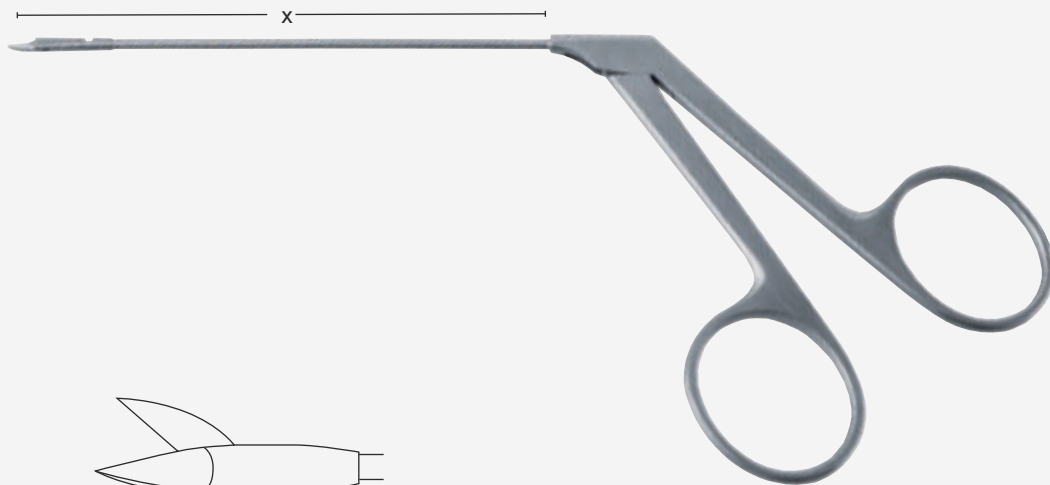

**Wullstein**

**18-982-08**

x = 8 cm - 3 1/4"

a x b

straight, sharp/sharp  
gerade, spitz/spitz  
recta, aguda/aguda  
droit, pointue/pointue  
retta, acuta/acuta



**18-983-08** 4.0 mm x 0.8 mm

x = 8 cm - 3 1/4"

curved upwards, sharp/sharp  
aufgebogen, spitz/spitz  
curvada arriba, aguda/aguda  
coudée en haut, pointue/pointue  
curvata in alto, acuta/acuta



**Wullstein**

**18-984-08**

x = 8 cm - 3 1/4"

a x b

curved to right, sharp/sharp  
rechts gebogen, spitz/spitz  
curvada a la derecha, aguda/aguda  
coudé à droite, pointue/pointue  
curvata a destra, acuta/acuta



**18-985-08** 4.0 mm x 0.8 mm

x = 8 cm - 3 1/4"

curved to left, sharp/sharp  
links gebogen, spitz/spitz  
curvado a la izquierda, aguda/aguda  
coudée à gauche, pointue/pointue  
curvata a sinistra, acuta/acuta



**Plester**  
 18-986-16

Wireguide  
 Führungsgabel  
 Tenedor guía  
 Fourchette d'introduction  
 Forchetta guida



18-987-16

Raspatory  
 Raspatorium  
 Raspatorio  
 Rugine  
 Raspatorio



18-988-16 16 cm - 6 1/4"

Elevator  
 Elevatorium  
 Elevador  
 Élévateur  
 Elevatorio



18-989-00

1.8 mm  
 Raspatory  
 Raspatorium  
 Raspatorio  
 Rugine  
 Raspatorio



18-990-00

1.0 mm  
 Raspatory  
 Raspatorium  
 Raspatorio  
 Rugine  
 Raspatorio



18-991-00

Dissector, double curved left  
 Dissektor, doppelt links gebogen  
 Disector, doble curvado a la izquierda  
 Dissecteur, double courbe à gauche  
 Dissettore doppio curvato a sinistra



18-992-16

Dissector, double curved right  
 Dissektor, doppelt rechts gebogen  
 Disector, doble curvado a la derecha  
 Dissecteur, double courbe à droite  
 Dissettore, doppio curvato a destra



18-993-16 16 cm - 6 1/4"

Instrument for placing wire prothesis  
 Handinstrument zum Andrücken von Drahtprothesen  
 Instrumento para posicionar protésis de alambre  
 Instrument pour mettre en place des protheses en fils métalliques  
 Strumento per posizionare prothesi di fili metallici



**House**

18-994-01 3.5 mm  
 18-994-02 4.0 mm  
 18-994-03 4.5 mm  
 18-994-05 5.0 mm

16 cm - 6 1/4"  
 Measuring rod  
 Messsonde  
 Sonda para medir  
 Sonde à mesurer  
 Sonda per misurare



**Rosen**

18-995-16

1.5 mm Ø - 90°  
Circular cutting knife  
Rundschnittmesser  
Cuchillo redondo  
Couteau rond  
Coltello rotondo



18-996-16

45°  
Tympanum knife  
Trommelfellmesser  
Cuchillo para el timpano  
Couteau pour le tympan  
Coltello per timpani



18-997-16

45°  
Lancet knife  
Lanzennmesser  
Cuchillo lanceolado  
Couteau lancéolaire  
Coltello lancelato



18-998-16 16 cm - 6 ¼"

Lancet knife  
Lanzennmesser  
Cuchillo lanceolado  
Couteau lancéolaire  
Coltello lancelato



**Schuhknecht**

18-999-16

Rollerknife, parallel  
Rollermesser, parallell  
Cuchillo redondo, vertical  
Couteau à lame,  
tournante, verticale  
Coltello rotondo, parallelo



18-100-16 16 cm - 6 ¼"

Rollerknife, right angled  
Rollermesser, rechtwinklig  
Cuchillo redondo, horizontal  
Couteau à lame,  
tournante, horizontale  
Coltello rotondo, orizzontale



18-101-00

Sickle knife,  
slightly curved  
Sichelmesser,  
leicht gebogen  
Cuchillo de hoz,  
ligeramente curvado  
Couteau faucille,  
légèrement courbe  
Coltello a ferma di falce,  
legermente curvo



18-102-00

Discision knife,  
straight  
Diszisionsmesser,  
gerade  
Cuchillo de discición,  
recto  
Couteau à discision,  
droit  
Coltello di dissezione,  
retto



**Plester**

18-103-16 16 cm - 6 ¼"

Flap knife  
Lappenmesser  
Cuchillo para lobulos  
Couteau à lambeaux  
Coltello per stacci



18-104-01 3.0 mm Ø

18-104-02 2.6 mm Ø

18-104-03 2.0 mm Ø

18-104-04 1.5 mm Ø

18-104-05 1.0 mm Ø

16 cm - 6 ¼"  
45°  
Circular cutting knife  
Rundschnittmesser  
Cuchillo redondo  
Couteau rond  
Coltello rotondo



**Zöllner**

18-105-16

1 mm  
Raspatory  
Raspatorium  
Raspatorio  
Rugine  
Raspatorio



18-106-16 16 cm - 6 ¼"

1 mm  
Raspatory  
Raspatorium  
Raspatorio  
Rugine  
Raspatorio



**Zöllner**

18-107-00 13 cm - 5"

90°  
 Roundknife, angled up  
 Rundschnittmesser, nach oben gebogen  
 Cuchillo redondo, angulado arriba  
 Coureau rond, coudé en haut  
 Coltello rotondo, angolato in alto



18-108-00 13 cm - 5"

90°  
 Roundknife, angled down  
 Rundschnittmesser, nach unten gebogen  
 Cuchillo redondo, angulado a bajo  
 Coureau rond, coudé en bas  
 Coltello rotondo, angolato in basso



18-109-00 13 cm - 5"

Sickleknife, angled up  
 Sichelmesser, nach oben gebogen  
 Cuchillo de hoz, angulado arriba  
 Coureau faucille, courbe vers le haut  
 Coltello a forma di falce, angolato in alto



18-110-00 13 cm - 5"

Sickleknife, angled down  
 Sichelmesser, nach unten gebogen  
 Cuchillo de hoz, angulado a bajo  
 Coureau faucille, courbe vers le bas  
 Coltello a forma di falce, curvato in basso



18-111-00 13 cm - 5"

Lancetknife, curved to left  
 Lanzenmesser, links gebogen  
 Cuchillo lanceolado, angulado a la izquierda  
 Coureau lancéolaire, courbe à gauche  
 Coltello lancelato, curvato a sinistra



18-112-00 13 cm - 5"

Lancetknife, curved to right  
 Lanzenmesser, rechts gebogen  
 Cuchillo lanceolado, angulado a la derecha  
 Coureau lancéolaire, courbe à droite  
 Coltello lancelato, curvato a destra



18-113-00 13 cm - 5"

Raspatory, curved to left  
 Raspatorium, links gebogen  
 Raspatorio, angulado a la izquierda  
 Décolleur, courbe à gauche  
 Raspatorio, curvato a sinistra



18-114-00 13 cm - 5"

Raspatory, curved to right  
 Raspatorium, rechts gebogen  
 Raspatorio, angulado a la derecha  
 Décolleur, courbe à droite  
 Raspatorio, curvato a destra



18-115-00 13 cm - 5"

Wire guide  
 Führungsgabel  
 Tenedor guía  
 Fourchette d'introduction  
 Forchetta guida



**Zöllner**

18-116-00 13 cm - 5"

Needlefine, straight, sharp  
Nadel fein, gerade, spitz  
Aguja fina, recta, aguda  
Aiguille fine, droite, pointue  
Ago fino, retto, acuto

18-117-00 13 cm - 5"

0.5 mm - 90°  
Hook, angled up  
Häkchen, nach oben gebogen  
Gancho, curvado arriba  
Crochet, coudé en haut  
Uncino, curvato in alto

18-118-00 13 cm - 5"

0.5 mm - 45°  
Hook, angled down  
Häkchen, nach unten gebogen  
Gancho, curvado a bajo  
Crochet, coudé en bas  
Uncino, curvato in basso

18-119-00 13 cm - 5"

0.5 mm - 90°  
Hook, angled up  
Häkchen, nach oben gebogen  
Gancho, curvado arriba  
Crochet, coudé en haut  
Uncino, curvato in alto

18-120-00 13 cm - 5"

0.5 mm - 90°  
Hook, angled down  
Häkchen, nach unten gebogen  
Gancho, curvado a bajo  
Crochet, coudé en bas  
Uncino, curvato in basso

18-121-00 13 cm - 5"

1.0 mm - 45°  
Hook, angled up  
Häkchen, nach oben gebogen  
Gancho, curvado arriba  
Crochet, coudé en haut  
Uncino, curvato in alto

18-122-00 13 cm - 5"

1.0 mm - 45°  
Hook, angled down  
Häkchen, nach unten gebogen  
Gancho, curvado a bajo  
Crochet, coudé en bas  
Uncino, curvato in basso

18-123-00 13 cm - 5"

1.0 mm  
Hook, curved up  
Häkchen, rund nach oben gebogen  
Gancho, redondo, curvado arriba  
Crochet, courbure rond vers le haut  
Uncino, rotondo, curvato in alto

18-124-00 13 cm - 5"

1.0 mm  
Hook, curved down  
Häkchen, rund nach unten gebogen  
Gancho, redondo, curvado a bajo  
Crochet, courbure rond ver le bas  
Uncino, rotondo, curvato in basso



18-125-16

16 cm - 6 1/4"

Needle fine, straight, sharp  
 Nadel fein, gerade, spitz  
 Aguja fina, recta, aguda  
 Aiguille fine, droite, pointue  
 Ago fino, retto, acuto

18-126-16

16 cm - 6 1/4"

Needle, slightly curved, sharp  
 Nadel, leicht gebogen, spitz  
 Aguja, ligeramente curva, aguda  
 Aiguille, legerement courbe, pointue  
 Ago, legeremente curvato, acuto

18-127-16

16 cm - 6 1/4"

Needle, strong curved, sharp  
 Nadel, stark gebogen, spitz  
 Aguja, muy curvada, aguda  
 Aiguille, tres courbe, pointue  
 Ago, fortemente curvato, acuto

**Shambaugh**

18-128-01

18-128-02

18-128-03

18-128-04

45°  
 16 cm - 6 1/4"

Hook, angled  
 Hakchen, abgewinkelt  
 Gancho, acodado  
 Crochet, coude  
 Uncino, angolato

18-129-01

18-129-02

18-129-03

18-129-04

90°

0.4 mm

0.6 mm

0.8 mm

1.0 mm

18-130-01

18-130-02

16 cm - 6 1/4"

Hook, retrograd  
 Hakchen, retrograd gebogen  
 Gancho, acodado, retrogrado  
 Crochet, courbe retrograde  
 Uncino, curvato reterogrado

1.0 mm

2.5 mm

18-131-16

0.6 mm

Hook, retrograd  
 Hakchen, retrograd gebogen  
 Gancho, acodado, retrogrado  
 Crochet, courbe retrograde  
 Uncino, curvato reterogrado

16 cm - 6 1/4"

**Barbara**

18-132-00

16 cm - 6 1/4"  
 sharp/straight  
 spitz/gerade  
 aguda/recta  
 pointue/droite  
 acuto/retta

18-133-00

16 cm - 6 1/4"  
 blunt/angled  
 stumpf/gewinkelt  
 roma/angulada  
 mousse/coude  
 smusso/angolato

18-134-00

16 cm - 6 1/4"  
 sharp/curved  
 spitz/gebogen  
 aguda/curva  
 pointue/courbe  
 acuto/curve

**Plester**

18-135-00 0.4 mm - 90°

16 cm - 6 1/4"  
 Foot plate hook, angled, blunt  
 Fussplattenhakchen, abgewinkelt, stumpf  
 Gancho, para placa de aido, romo  
 Crochet pour la platine de l'etrier, mousse  
 Uncino per placca di piede, smusso

**Plester**

18-136-00 0.4 mm - 45°

16 cm - 6 1/4"  
 Antrum hook, angled, blunt  
 Antrum Hakchen, aufgewinkelt, stumpf  
 Gancho para el antrum, acododo, romo  
 Crochet pour l'antre, coude, mousse  
 Uncino per antrum, angolato in alto, smusso





### Shambaugh

18-137-01

18-137-02

18-137-03

16 cm - 6 1/4"

90°

Hook, curved up

Häkchen, nach oben gebogen

Gancho, curvado arriba

Crochet, coudé en haut

Uncino, curvato in alto

18-138-01

0.3 mm

18-138-02

0.6 mm

18-138-03

1.0 mm

16 cm - 6 1/4"

90°

Hook, curved down

Häkchen, nach unten gebogen

Gancho, curvado a bajo

Crochet, coudé en bas

Uncino, curvato in basso

### McGee

18-139-01

18-139-02

18-139-03

16 cm - 6 1/4"

Hook, round, curved up

Häkchen, rund, nach oben gebogen

Gancho, redondo, curvado arriba

Crochet, courbé ronde, vers le haut

Uncino, rotondo, curvato in alto

18-140-01

0.3 mm

18-140-02

0.6 mm

18-140-03

1.0 mm

16 cm - 6 1/4"

Hook, round, curved down

Häkchen, rund, nach unten gebogen

Gancho, redondo, curvado arriba

Crochet, courbé ronde vers le bas

Uncino, rotondo, curvato in basso

### Barbara

18-141-15 15.5 mm - 6"

0.5 mm

### Rosen

18-142-16 16 cm - 6"

0.5 mm

Needle, slightly curved

Nadel, leicht gebogen

Aguja, ligeramente curvado

Aiguille, légèrement courbée

Ago, legermente curvato

### McGee

18-143-01

18-143-02

18-143-03

16 cm - 6 1/4"

25°

Hook, curved up

Häkchen, nach oben gebogen

Gancho, curvado arriba

Crochet, coudé en haut

Uncino, curvato in alto

### McGee

18-144-01

18-144-02

18-144-03

16 cm - 6 1/4"

25°

Hook, curved down

Häkchen, nach unten gebogen

Gancho, curvado a bajo

Crochet, coudé en bas

Uncino, curvato in basso

### McGee

18-145-01

18-145-02

18-145-03

16 cm - 6 1/4"

45°

Hook, curved up

Häkchen, nach oben gebogen

Gancho, curvado arriba

Crochet, coudé en haut

Uncino, curvato in alto

### McGee

18-146-01 0.3 mm

18-146-02 0.6 mm

18-146-03 1.0 mm

16 cm - 6 1/4"

45°

Hook, curved

Häkchen, nach unten gebogen

Gancho, curvado a bajo

Crochet, coudé en bas

Uncino, curvato in basso



**Fisch**

**18-147-15**

15.5 cm - 6"  
 angled to the right  
 rechts abgewinkelt  
 angulado por la derecha  
 coudé à droite  
 angolato a destra



**18-148-15**

15.5 cm - 6"  
 angled to the left  
 links abgewinkelt  
 angulado por la izquierda  
 coudé à gauche  
 angolato a sinistra



**18-149-15**

15.5 cm - 6"  
 angled to the right  
 rechts abgewinkelt  
 angulado por la derecha  
 coudé à droite  
 angolato a destra



**18-150-15**

15.5 cm - 6"  
 angled to the left  
 links abgewinkelt  
 angulado por la izquierda  
 coudé à gauche  
 angolato a sinistra

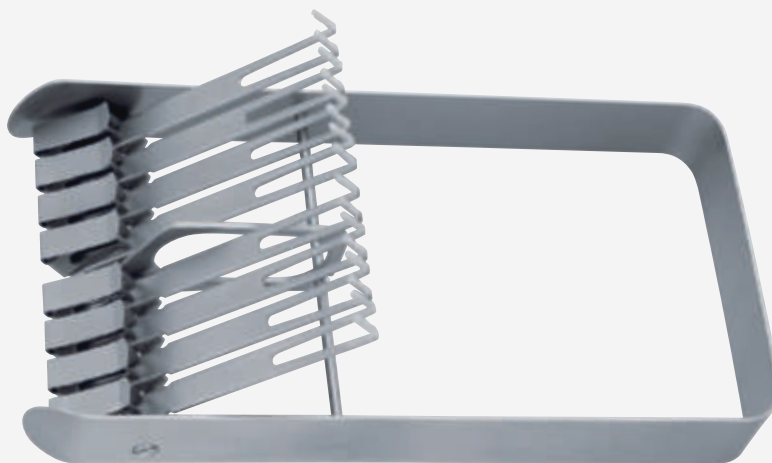

**Bekko**

**18-151-00**

Rack for 8 each micro ear instruments with hexagonal or octagonal handle  
 Rack für 8 Mikro-Ohr-Instrumente mit Sechs- oder Achkantgriff  
 Soporte para 8 micro-instrumentos con mangos hexagonales o octogonales  
 Etagère pour 8 micro-instruments avec manches hexagonales o octogonales  
 Supporto per 8 strumenti micro con manico esagonale e ottagonale



**House**

18-152-17 17 cm - 6 3/4"

Spoon, strong curved  
Löffel, stark gebogen  
Cureta, muy curvada  
Curette, fortement coudée  
Cucchaio, fortemente curvato

18-153-17 17 cm - 6 3/4"

Spoon, slightly curved  
Löffel, leicht gebogen  
Cureta, ligeramente curvada  
Curette, légèrement coudée  
Cucchaio, legeremente curvato



**Shea**

18-154-16

16 cm - 6 1/4"  
straight  
gerade  
recta  
droits  
retto



18-155-00 1.5 mm x 2.5 mm

curved  
gebogen  
curva  
courbe  
curvo



House

18-160-15

1.0mm Ø and 1.2mm Ø  
 Spoon, slightly curved  
 Löffel, leicht gebogen  
 Cureta, ligeramente curvada  
 Curette, légèrement coudée  
 Cucchiaio, legeremente curvato



House

18-156-15 15 cm - 6"

1.0 mm Ø and 1.2 mm Ø  
 Spoon strong curved  
 Löffel stark gebogen  
 Cureta, muy curvada  
 Curette fortement coudée  
 Cucchiaio, fortemente curvato



18-157-15 15 cm - 6"

1.5 mm Ø and 1.8 mm Ø  
 Spoon strong curves  
 Löffel stark gebogen  
 Cureta, muy curvada  
 Curette fortement coudée  
 Cucchiaio, fortemente curvato

House

18-158-15 15 cm - 6"

1.0 mm Ø and 1.2 mm Ø

18-159-15 15 cm - 6"

1.5 mm Ø and 1.8 mm Ø



18-161-15 15 cm - 6"

1.5mm Ø and 1.8 mm Ø  
 Spoon, slightly curves  
 Löffel, leicht gebogen  
 Cureta, ligeramente curvada  
 Curette, légèrement coudée  
 Cucchiaio, legeremente curvato

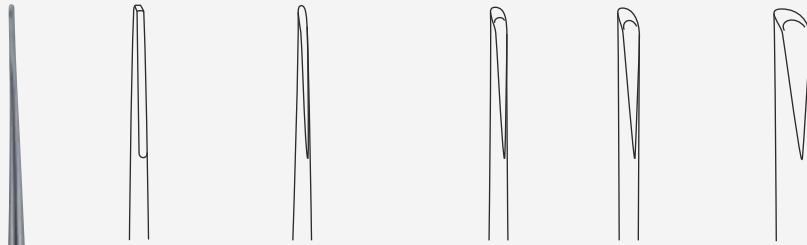

Heermann

18-162-01	18-163-02	18-164-03	18-165-04	18-166-05
0.7mm	0.7mm	1.0mm	1.5mm	3.0mm
Chisel	Gouge	Gouge	Gouge	Gouge
Flachmeissel	Hohlmeissel	Hohlmeissel	Hohlmeissel	Hohlmeissel
Escoplo	Gubia	Gubia	Gubia	Gubia
Ciseaux	Gouge	Gouge	Gouge	Gouge
Scalpello	Sgorbia	Sgorbia	Sgorbia	Sgorbia



Heermann

18-167-00

Handle for chisels  
Handgriff für Meissel  
Mango para escoplos  
Manche pour ciseaux  
Manico per scalpelli/sgorbie



Heermann

18-168-19 19.5 cm - 7 3/4"

Metal hammer  
Hammer, Metall  
Martillo, de metal  
Maillet en métal  
Martello, acciaio

Cottle

18-169-19 19 cm - 7 1/2"

250 g  
Metal hammer  
Hammer, Metall  
Martillo, de metal  
Maillet en métal  
Martello, acciaio



Wullstein

18-170-16

16 cm - 6 1/4"  
 straight  
 gerade  
 recta  
 droite  
 rette

18-171-16

16 cm - 6 1/4"  
 curved  
 gebogen  
 curva  
 courbe  
 curvo



Rosen  
 Fig. 1

18-172-17

2.5 mm  
 bayonet shaped  
 bajonettförmig  
 en forma de bayoneta  
 en forme de baionette  
 forma a baionetta



Fig. 2

18-173-17

17.5 cm - 7"

1.5 mm  
 bayonet shaped  
 bajonettförmig  
 en forma de bayoneta  
 en forme de baionette  
 forma a baionetta



Lempert

18-174-16

16 cm - 6 1/4"

3.0 mm

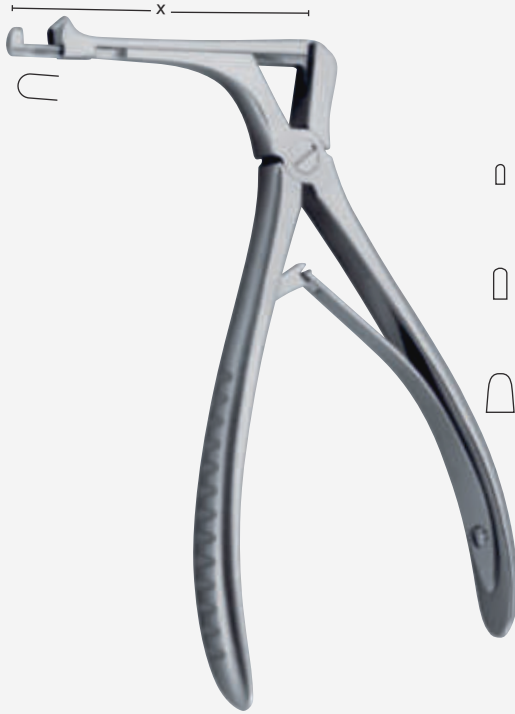

**Citelli**

- 18-175-17 17 cm - 6 ¾"  
x = 60 mm  
1.5 mm
- 18-176-17 17 cm - 6 ¾"  
2.2 mm
- 18-177-17 17 cm - 6 ¾"  
3.0 mm



**Kerrison**

- |            |           |           |           |           |
|------------|-----------|-----------|-----------|-----------|
| 18-178-20  | 18-179-20 | 18-180-20 | 18-181-20 | x = 80 mm |
| 3 x 3 mm   | 4 x 4 mm  | 5 x 5 mm  | 6 x 6 mm  |           |
| 20 cm - 8" |           |           |           |           |



Beyer

18-182-14 14 cm - 5 ½"

1 mm



Beyer

18-183-19 19 cm - 7 ½"

2 mm



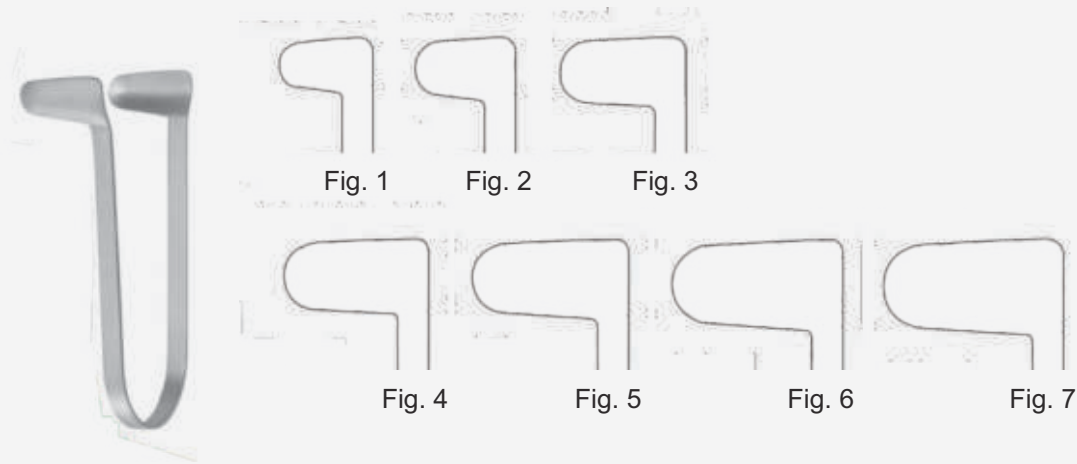

**Thudichum  
(Mark Hovell)**

18-328-01	Fig. 1	8.5x6 mm
18-328-02	Fig. 2	9.0x7 mm
18-328-03	Fig. 3	12.5x8 mm
18-328-04	Fig. 4	15x8.5 mm
18-328-05	Fig. 5	16.5x9 mm
18-328-06	Fig. 6	18x10 mm
18-328-07	Fig. 7	19.5x10.5 mm

18-328-00

Set of 7 pcs. Fig. 1 - 7

**Thudichum  
(Mark Hovell)**

18-329-01	Fig. 1	8.5x6 mm
18-329-02	Fig. 2	9.0x7 mm
18-329-03	Fig. 3	12.5x8 mm
18-329-04	Fig. 4	15x8.5 mm
18-329-05	Fig. 5	16.5x9 mm
18-329-06	Fig. 6	18x10 mm
18-329-07	Fig. 7	19.5x10.5 mm

Insulated

18-329-00

Set of 7 pcs. Fig. 1 - 7

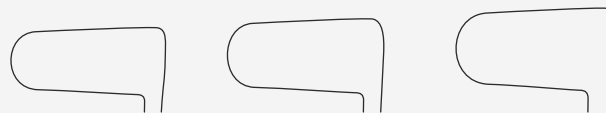

**Thudichum  
(Goldsmith)**

18-236-06

21 mm x 9.5 mm

18-237-06

21 mm x 10.5 mm

18-238-06

21 mm x 11.5 mm

6.5 cm - 2 1/4"

18-236-00

Set of 3 pcs.

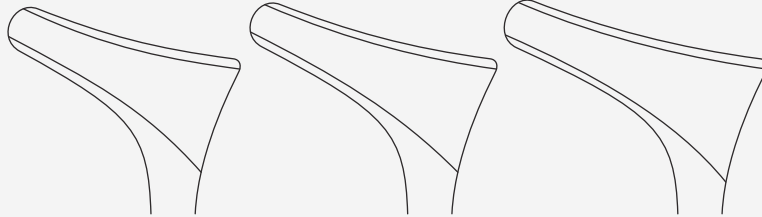

**Hartmann**

18-239-16

Fig. 1

18-240-16

Fig. 2

18-241-16

16 cm - 6 ¼"

Fig. 3

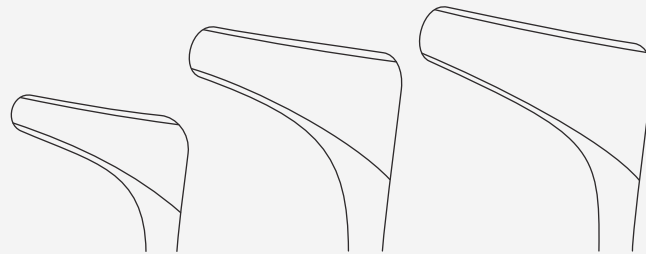

**Hartmann-Halle**

18-242-15

Fig. 1

18-243-15

Fig. 2

18-244-15

15 cm - 6"

Fig. 3



**Tieck-Halle**

18-245-13 13.5 cm - 5 ¼"

for babies  
 für Säuglinge  
 para lactantes  
 pour nourrissons  
 per lattanti

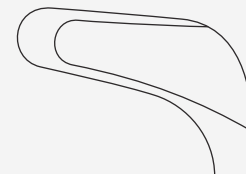
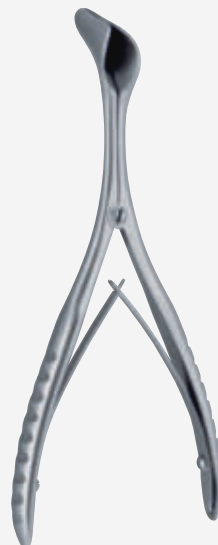

**Schwarz**

18-246-14 14 cm - 5 ¼"



**Killian**

18-247-13

x = 35 mm

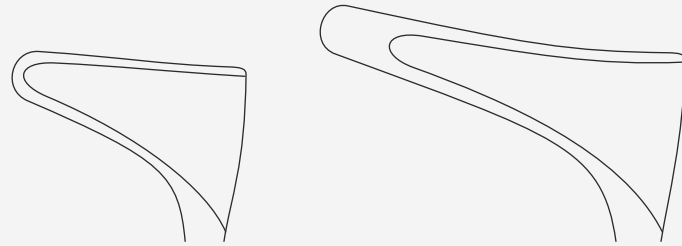

18-248-13 13 cm - 5"

x = 50 mm

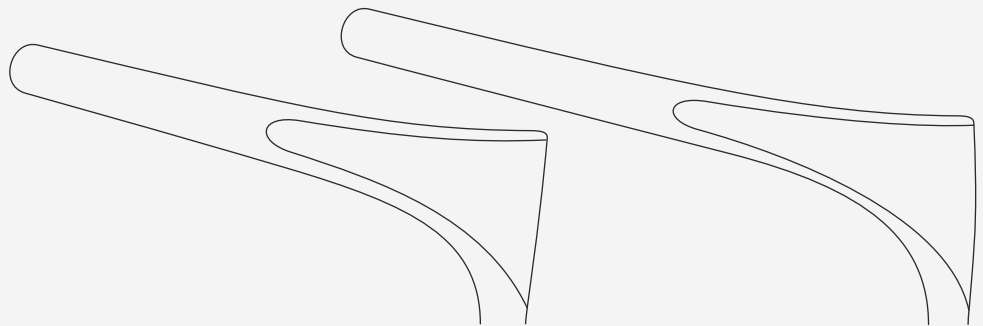

18-249-13

x = 75 mm

18-250-13 13 cm - 5"

x = 90 mm

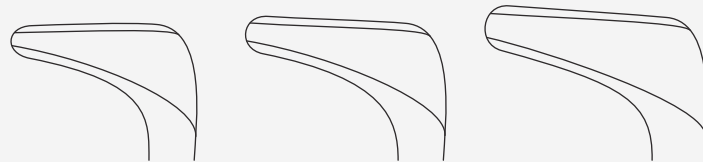

**Beckmann**

18-251-15

Fig. 1

18-252-15

Fig. 2

18-253-15 15 cm - 6"

Fig. 3

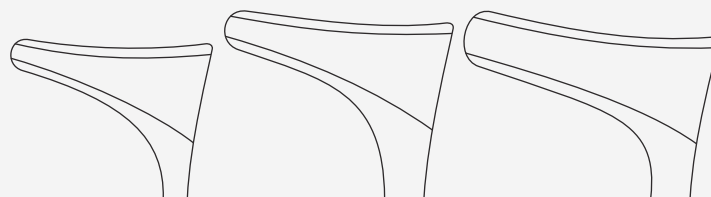

**Mod. Wien**

18-254-14

Fig. 1

18-255-14

Fig. 2

18-256-14 14.5 cm - 5 3/4"

Fig. 3

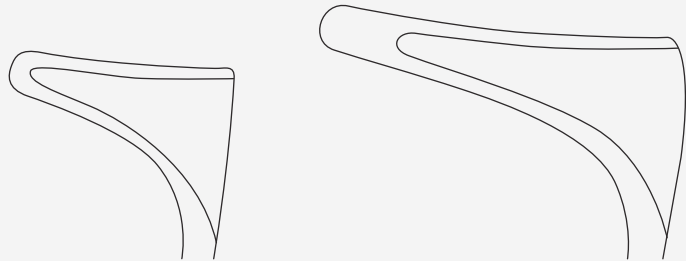

Cottle

18-257-15

x = 35 mm

18-258-15 15 cm - 6"

x = 50 mm

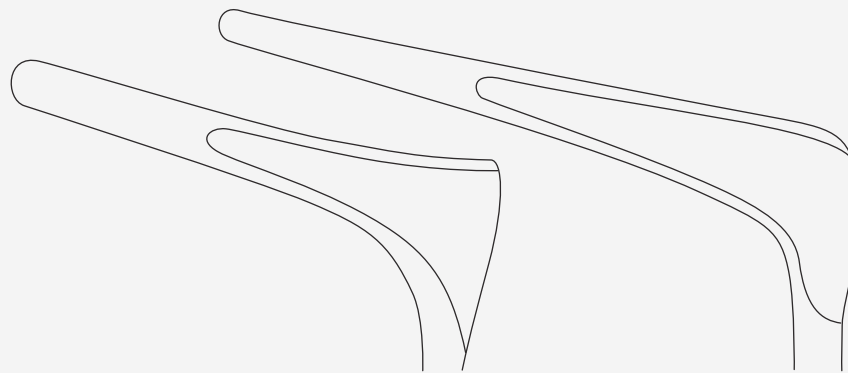

18-259-15

x = 75 mm

18-260-15 15 cm - 6"

x = 90 mm

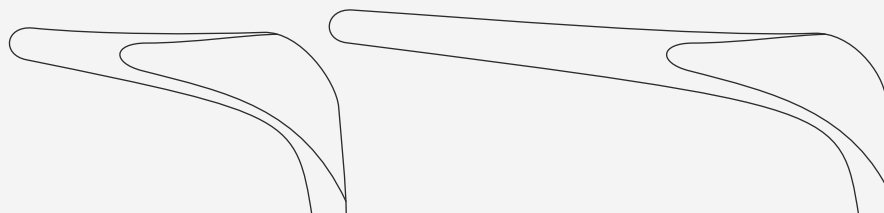

Cottle

18-261-14B

x = 45 mm

black, chrome plated  
 schwarz verchromt  
 cromado en negro  
 chromé en noir  
 cromato nero

18-262-14B 14 cm - 5 ½"

x = 75 mm



Westmacott

18-263-20 20 cm - 8"



Lubet-Barbon

18-264-20 20 cm - 8"



Hartmann

18-265-16 16 cm - 6 ¼"

18-265-20 20 cm - 8"



Tilley

18-266-14 14 cm - 5 ½"



Heymann-Knight

18-267-18 18 cm - 7"



Craig

18-268-18 18 cm - 7"

Nasal cutting forceps  
 Scharfe Nasenzangen  
 Pinzas nasales cortantes  
 Pincas coupantes pour le nez  
 Nasale taglio forcipe

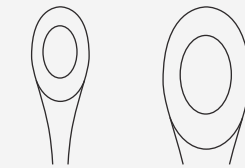

Luc

18-275-20    18-276-20    20 cm - 8"

Fig. 1    Fig. 2

fenestrated  
 gefenstert  
 fenestrado  
 fenêtré  
 finestrato

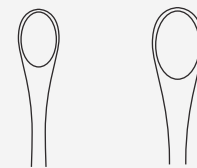

18-277-01    18-278-02

Fig. 1    Fig. 2

plaine  
 voll  
 lleno  
 pleine  
 pieno

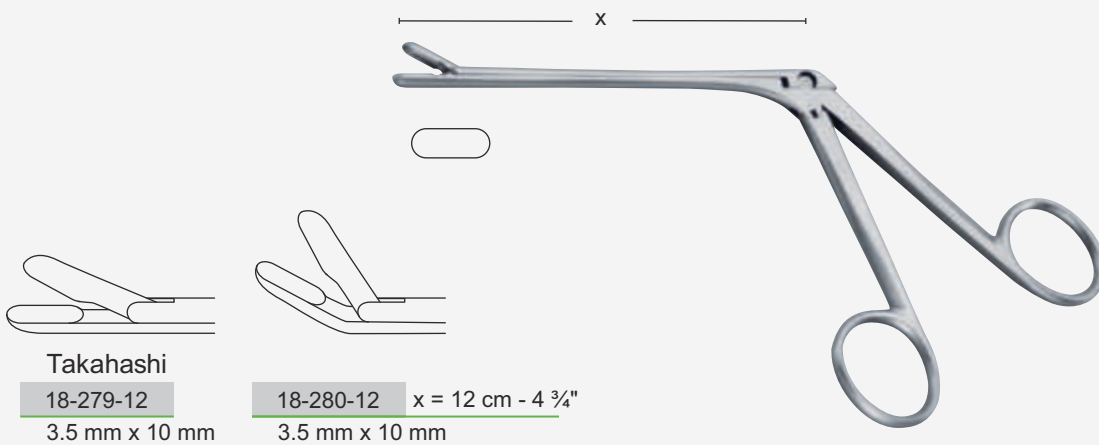

Takahashi

18-279-12  
 3.5 mm x 10 mm

18-280-12    x = 12 cm - 4 3/4"  
 3.5 mm x 10 mm

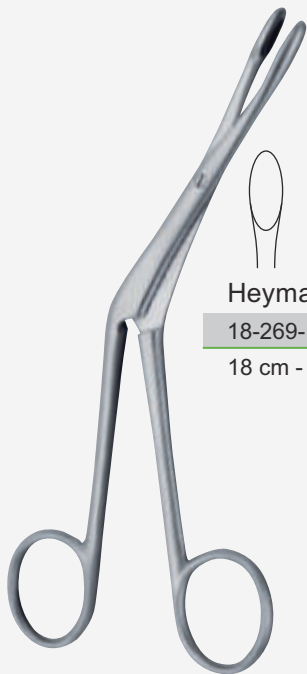

Heymann

18-269-18

18 cm - 7"



18-270-18

18 cm - 7"



18-271-18

18 cm - 7"

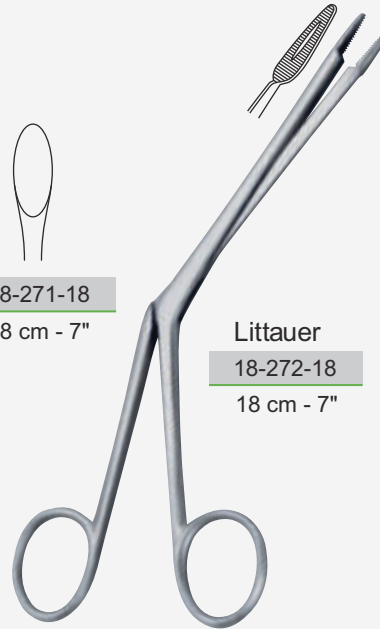

Littauer

18-272-18

18 cm - 7"



Knight

18-273-18

18 cm - 7"

Nasal dressing forceps  
Nasentamponzange  
Pinza nasale para tamponiamento  
Pince à pansement pour le nez  
Pinza per tamponamento nasale

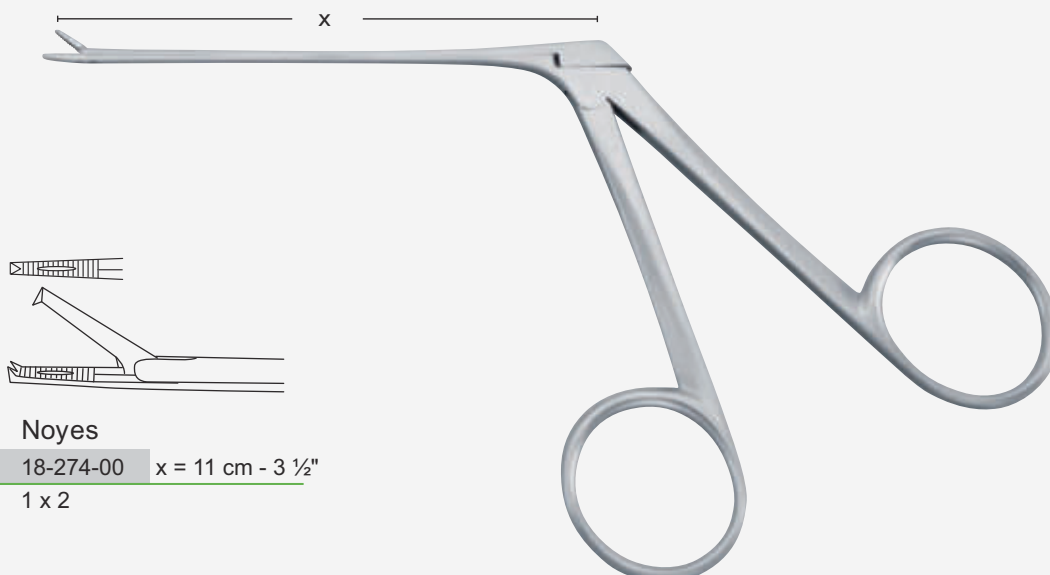

Noyes

18-274-00 x = 11 cm - 3 1/2"

1 x 2

Nasal cutting forceps  
 Scharfe Nasenzangen  
 Pinzas nasales cortantes  
 Pincas coupantes pour le nez  
 Nasale taglio forcipe



Bruenings

18-281-19



18-282-19



18-283-19



18-284-19



19 cm - 7 1/2"

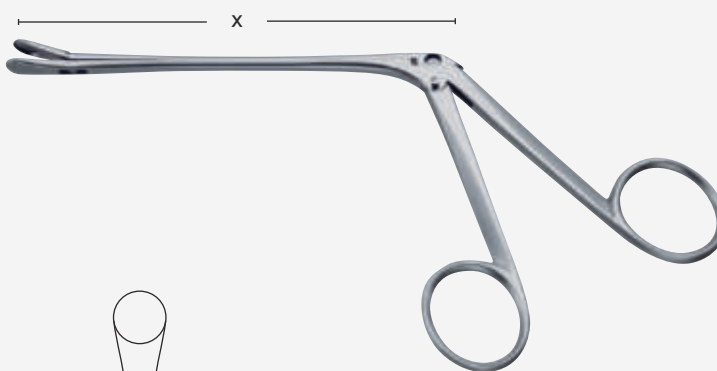

Weil

18-285-12

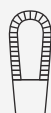

Watson-Williams

18-286-12



18-287-12

x = 12 cm - 4 3/4"



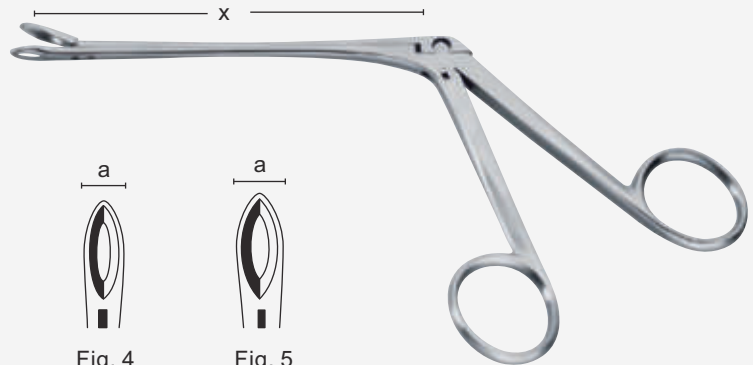

Fig. 1



Fig. 2



Fig. 3



Fig. 4



Fig. 5

**Weil-Blakesley**



0°

18-288-12  
a = 3.0mm

18-289-12  
a = 3.5mm

18-290-12  
a = 4.5mm

18-291-12  
a = 5.0mm

18-292-12  
a = 5.5mm

x = 12 cm - 4 3/4"



45°

18-293-00  
a = 3.0mm

18-294-00  
a = 3.5mm

18-295-00  
a = 4.5mm

18-296-00  
a = 5.0mm



90°

18-297-00  
a = 3.0mm

18-298-00  
a = 3.5mm

18-299-00  
a = 4.5mm



45°

Fig. 1  
18-300-18  
a = 3.0 mm

Fig. 2  
18-301-18  
a = 3.5 mm

Fig. 3  
18-302-18  
a = 4.5 mm

Fig. 4  
18-303-18  
a = 5.0 mm

Fig. 5  
18-304-18  
a = 5.5 mm

x = 18 cm - 7"



90°

18-305-18  
a = 3.0 mm

18-306-18  
a = 3.5 mm

18-307-18  
a = 4.5 mm

18-308-18  
a = 5.0 mm

x = 18 cm - 7"



**Hartmann**

18-309-12  
5 mm

18-310-12  
7 mm

18-311-12  
9 mm

18-312-12  
11 mm

x = 12 cm - 4 3/4"

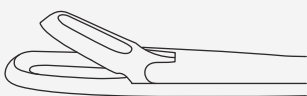

**Myles**

18-313-12

Fig. 1  
2.0 x 10.0 mm

18-314-12

Fig. 2  
2.5 x 12.0 mm

18-315-12

Fig. 3  
3.0 x 14.0 mm

x = 12 cm - 4 3/4"

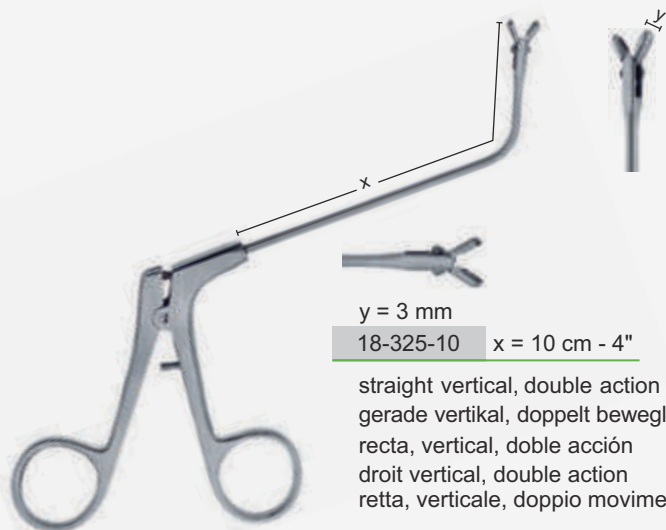

y = 3 mm  
 18-325-10 x = 10 cm - 4"

straight vertical, double action  
 gerade vertikal, doppelt beweglich  
 recta, vertical, doble acción  
 droit vertical, double action  
 retta, verticale, doppio movimento

y = 3 mm  
 18-326-10 x = 10 cm - 4"

straight hor., double action  
 gerade hor., doppelt beweglich  
 recta, horizontal, doble acción  
 droit horizontal, double action  
 retta oriz., doppio movimento

y = 3 mm  
 18-327-10 x = 10 cm - 4"

straight hor., single action, short  
 gerade hor., einfach beweglich, kurz  
 recta, hor., acción simple, corto  
 droit hor., action simple, court  
 retta, oriz., movimento sing., corto



y = 3 mm  
 18-328-10 x = 10 cm - 4"

45° vertical, double action  
 45° vertikal, doppelt beweglich  
 45° vertical, doble acción  
 45° vertical, double action  
 45° verticale, doppio movimento



y = 3 mm  
 18-329-10 x = 10 cm - 4"

45° hor., double action  
 45° hor., doppelt beweglich  
 45° hor., doble acción  
 45° hor., double action  
 45° oriz., doppio movimento

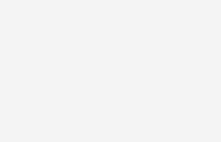

y = 3 mm  
 18-330-10 x = 10 cm - 4"

45° vert., single action, short  
 45° vert., einfach beweglich, kurz  
 45° vert., acción simple, corto  
 45° vert., action simple, court  
 45° vert., movimento sing., corto



y = 3 mm  
 18-331-10 x = 10 cm - 4"

70° vertical, double action  
 70° vertikal, doppelt beweglich  
 70° vertical, doble acción  
 70° vertical, double action  
 70° verticale, doppio movimento



y = 3 mm  
 18-332-10 x = 10 cm - 4"

70° hor., double action  
 70° hor., doppelt beweglich  
 70° hor., doble acción  
 70° hor., double action  
 70° oriz., doppio movimento



y = 3 mm  
 18-333-10 x = 10 cm - 4"

110° hor., double action  
 110° hor., doppelt beweglich  
 110° hor., doble acción  
 110° hor., double action  
 110° oriz., doppio movimento

y = 3 mm  
 18-334-10 x = 10 cm - 4"

70° vert., single action, short  
 70° vert., einfach beweglich, kurz  
 70° vert., acción simple, corto  
 70° vert., action simple, court  
 70° vert., movimiento sing., corto

y = 3 mm  
 18-335-10 x = 10 cm - 4"

70° hor., single action  
 70° hor., einfach beweglich  
 70° hor., acción simple, corto  
 70° hor., action simple, court  
 70° oriz., movimiento sing., corto

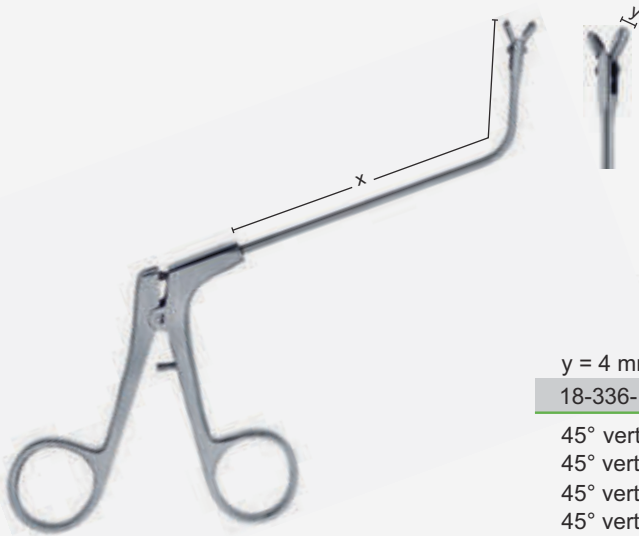

y = 4 mm  
18-336-10 x = 10 cm - 4"

45° vertical, double action  
45° vertikal, doppelt beweglich  
45° vertical, doble acción  
45° vertical, double action  
45° verticale, doppio movimento



y = 4 mm  
18-337-10 x = 10 cm - 4"

45° hor., double action, short  
45° hor., doppelt beweglich, kurz  
45° hor., acción doble, corto  
45° hor., double action, court  
45° oriz., movimento, corta

y = 4 mm  
18-338-10 x = 10 cm - 4"

45° vertical, single action, short  
45° vertikal, einfach beweglich, kurz  
45° vertical, acción simple, corto  
45° vertical, action simple, court  
45° verticale, movimento singolo, corta



y = 4 mm  
18-339-10 x = 10 cm - 4"

70° vertical, double action  
70° vertikal, doppelt beweglich  
70° vertical, doble acción  
70° vertical, double action  
70° verticale, doppio movimento



y = 4 mm  
18-340-10 x = 10 cm - 4"

70° hor., double action, short  
70° hor., doppelt beweglich, kurz  
70° hor., acción doble, corto  
70° hor., double action, court  
70° oriz., movimento, corta

y = 4 mm  
18-341-10 x = 10 cm - 4"

70° vertical, single action, short  
70° vertikal, einfach beweglich, kurz  
70° vertical, acción simple, corto  
70° vertical, action simple, court  
70° verticale, movimento singolo, corta

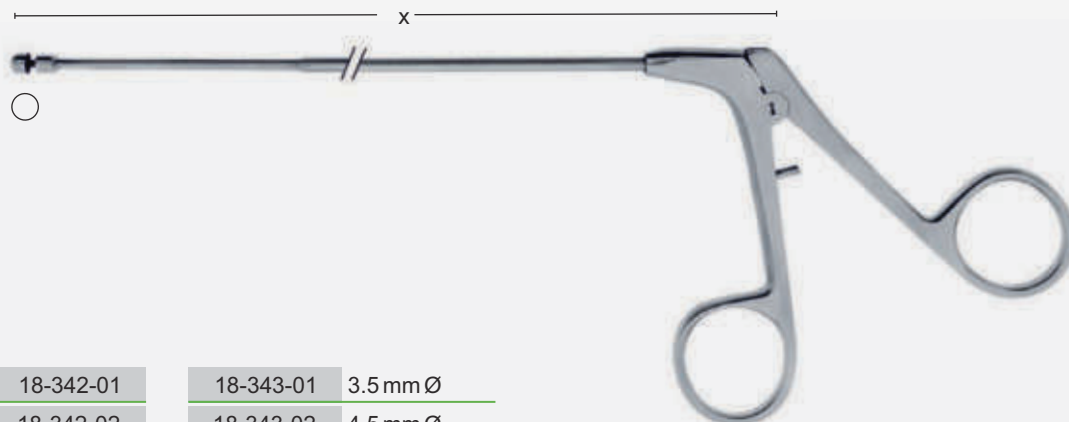

18-342-01

18-343-01 3.5 mm Ø

18-342-02

18-343-02 4.5 mm Ø

x = 180mm – 7"

x = 180mm – 7"

straight  
gerade  
recta  
droit  
retta

curved upwards  
aufgebogen  
curvada arriba  
coudé en haut  
curvata in alto



18-344-01

18-345-02

18-346-03 1.5 mm x 4.5 mm

Fig. 1

Fig. 2

Fig. 3

x = 100 mm

backward, up-cutting  
rückwärts nach oben schneidend  
retrograda corte arriba  
retrograde coupe en haut  
retrograda tagliente in alto

backward, cut to the right  
rückwärts nach rechts schneidend  
retrograda corte a la derecha  
retrograde coupe à droite  
retrograda tagliente a destra

backward, cut to the left  
rückwärts nach links schneidend  
retrograda corte a la izquierda  
retrograde coupe à gauche  
retrograda tagliente a sinistra



Hajek

18-347-14

x = 14 cm - 5 1/2"  
4 mm x 4 mm



Hajek-Kofler

18-348-14

x = 14 cm - 5 1/2"  
4 mm x 4 mm



Hajek

18-349-14

x = 14 cm - 5 1/2"  
4 mm x 4 mm



Hajek-Kofler

18-350-14

x = 14 cm - 5 1/2"  
4 mm x 4 mm



Hajek-Kofler

18-351-18 x = 18 cm - 7"

3.5 mm

Shaft rotates 360°

Schaft 360° drehbar

Tijera rotativa 360°

Tige orientable à 360°

Asta girevole 360°

Punches sphenoid bone  
 Keilbeinstanzen  
 Pinzas para esfenoides  
 Pincas pour le sinus sphénoïdal  
 Punzoni sfenoide



Hajek-Claus  
 18-352-20  
 20 mm - 8"

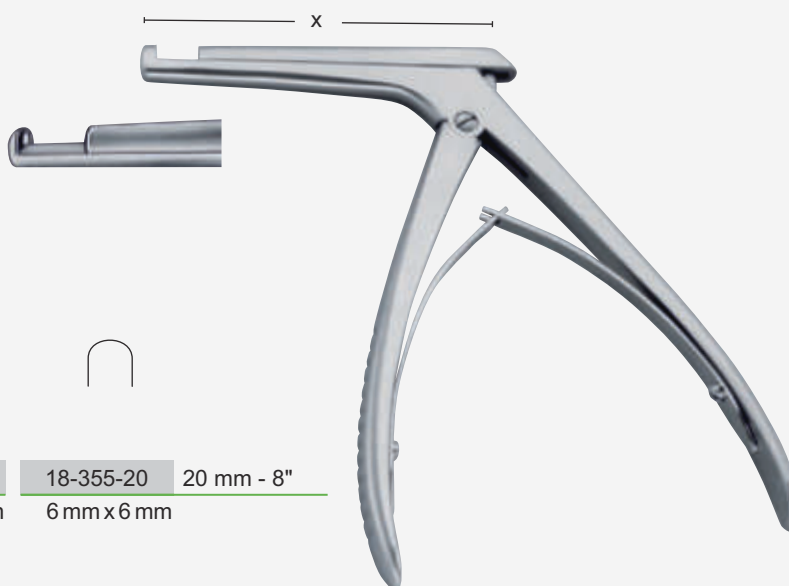

Kerrison

18-353-20	18-354-20	18-355-20	20 mm - 8"
4 mm x 4 mm	5 mm x 5 mm	6 mm x 6 mm	
x = 9 cm - 3 1/2"			



Snare  
18-356-00 0.3 mm Ø 100 mm



in bundles of 12 pieces  
in Bündeln mit 12 Stück  
en liós de 12 piezas  
en paquets de 12 pièces  
pacchetto di 12 pezzi



Krause  
18-357-26 26 cm - 10 ¼"



Krause-Voss  
18-358-26 26 cm - 10 ¼"

with 2 inserts  
mit 2 Aufsätzen  
con 2 guias  
avec 2 guide-anses  
con 2 guide ansa



Lange-Wilde  
18-359-24 24 cm - 9 ½"



**Fomon**  
 18-360-16  
 16.5 cm - 6 1/2"

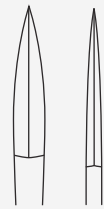

**Joseph**  
 18-361-16  
 Fig. 1  
 sharp/sharp  
 scharf/spitz  
 cortante/agudo  
 tranchant/pointu  
 acuto



18-362-16  
 Fig. 2  
 straight  
 gerade  
 recta  
 droit  
 retto



18-363-16  
 Fig. 1



18-364-16 16 cm - 6 1/4"  
 Fig. 2  
 curved  
 gebogen  
 curva  
 courbe  
 curvo

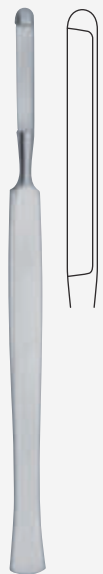

**Joseph**  
 18-365-14  
 14 cm - 5 1/2"



**Cottle**  
 18-366-15  
 15 cm - 6"



**Joseph**  
 18-367-17  
 17.5 cm - 7"



**Bruenings**  
 18-368-16  
 16.5 cm - 6 1/2"

18-369-00  
 Spareblade  
 Ersatzklinge  
 Hoja de recambio  
 Lame de rechange  
 Lama di ricambio





Freer  
18-370-19



18-371-19 19 cm - 6 1/2"



Converse  
18-372-16  
16 cm - 6 1/4"



Freer  
18-373-15  
15 cm - 6"



Freer  
18-374-15  
15 cm - 6"



Freer  
18-375-15  
15 cm - 6"



Freer

18-376-21



18-377-21 21 cm - 8 1/4"



Bruno

18-378-20

20 cm - 8"

Sickle knife

Sichelmesser

Cuchillo falciforme

Couteau à faucille

Coltello a forma di falce



Bruenings

18-379-23

23 cm - 9"



Abraham

18-380-22

22 cm - 8 3/4"



Fischer

18-381-23

23 cm - 9"

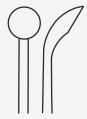

Fulker

18-383-20

20 cm - 8"



18-384-20

20 cm - 8"



Cema

18-385-20

20 cm - 8"  
7 mm x 11 mm



Pratt

18-386-21

21 cm - 8 1/4"



Faulkner

18-387-21

21 cm - 8 1/4"



Coakley

18-388-20

20 cm - 8"



Coakley

18-389-17

Fig. 1



18-390-17

Fig. 2



18-391-17

Fig. 3



18-392-17

Fig. 4



18-393-17

Fig. 5



18-394-17

Fig. 6

17 cm - 6 3/4"

18-389-00

Set of 6, Fig. 1 - 6

Septum elevators – raspatories  
 Septum elevatorien – Raspatorien  
 Elevadores – leguas para el tabique nasal  
 Elevateurs – rugines pour la cloison nasale  
 Ascensori setto - Raspatories



Lempert  
 Fig. 1

18-395-20  
 20.5 cm - 8"

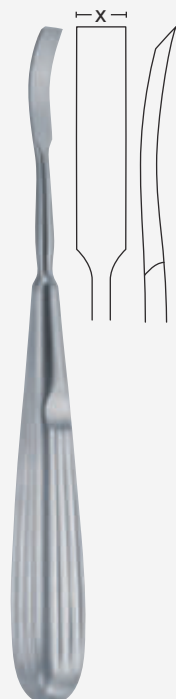

Fig. 2

18-396-18 x = 6 mm  
 18 cm - 7"



Freer

18-397-16 16 cm - 6 1/4"  
 x = 4 mm



Cottle

18-398-19 19 cm - 7 1/2"  
 x = 8 mm  
 sharp  
 scharf  
 cortante  
 tranchant  
 acuta



Joseph

18-399-00

x = 5 mm  
 Periostalevators  
 Periost Elevatorien  
 Periostotomo  
 Périostotome  
 Periostotomo



Sewall

18-400-20 20 cm - 8"

Antrum elevator  
 Antrum Elevatorium  
 Elevador para el antro  
 Elévateur pour le fosse nasale  
 Elevatore per antro



Halle

18-401-16  
 16 cm - 6 1/4"

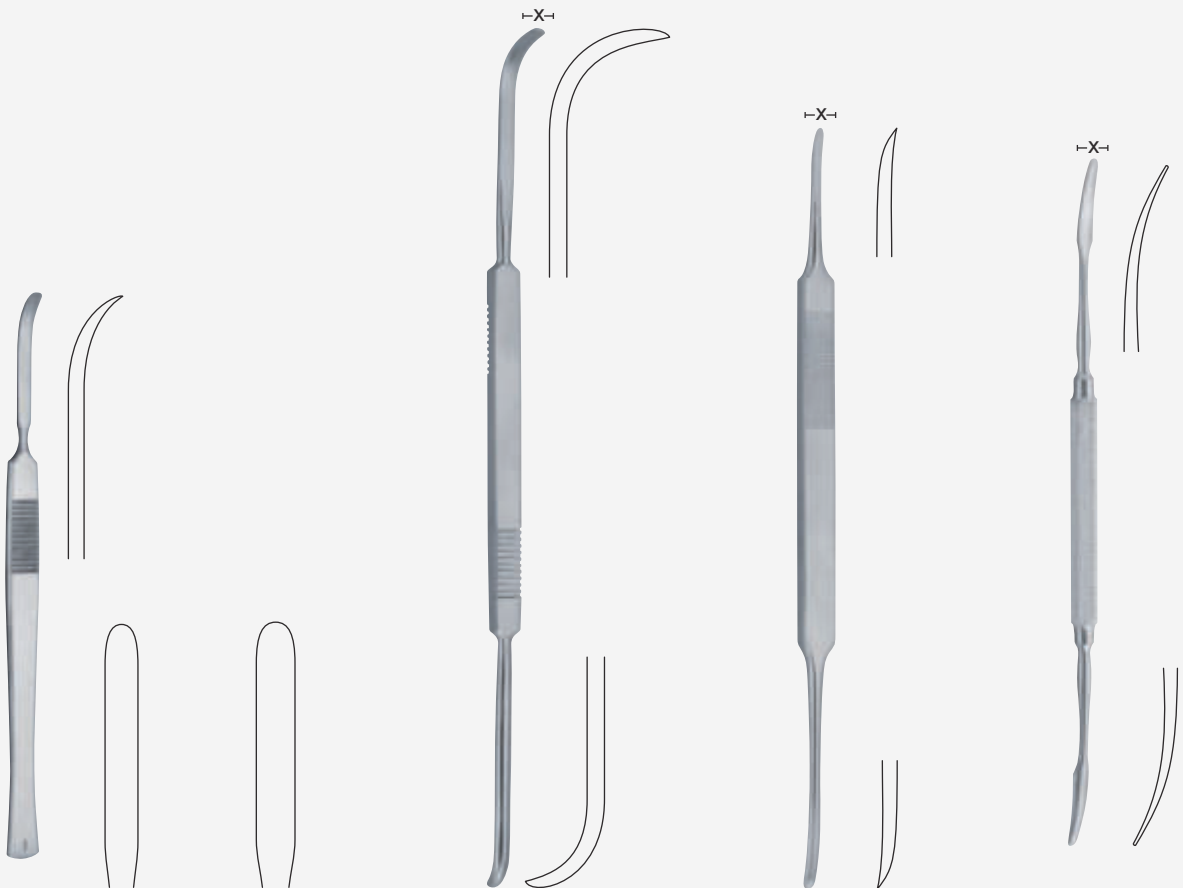

**McKenty**

**18-402-15**

15 cm - 6"  
4 mm

sharp  
scharf  
cortante  
tranchant  
acuta

**18-403-15**

15 cm - 6"  
5 mm

**Cottle**

**18-404-23**

23.5 cm - 9 1/4"  
x = 5 mm

sharp  
scharf  
cortante  
tranchant  
acuta

**McKenty**

**18-405-20**

20.5 cm - 8"  
x = 4 mm

sharp  
scharf  
cortante  
tranchant  
acuta

**Killian**

**18-406-18**

18 cm - 7"  
x = 4 mm

sharp/blunt  
scharf/stumpf  
cortante/romo  
tranchant/mousse  
acuta/smussa



**Killian**  
 18-407-23

23 cm - 9"  
 x = 4.5 mm  
 sharp/blunt  
 scharf/stumpf  
 cortante/romo  
 tranchant/mousse  
 acuta/smussa



**Freer**  
 18-408-19

19 cm - 7 ½"  
 blunt  
 stumpf  
 romo  
 mousse  
 smussa

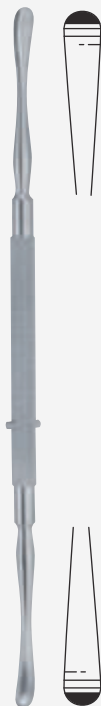

**Freer**  
 18-409-18

18 cm - 7"  
 sharp/blunt  
 scharf/stumpf  
 cortante/romo  
 tranchant/mousse  
 acuta/smussa



**Freer**  
 18-410-20

20.5 cm - 8"  
 sharp/blunt  
 scharf/stumpf  
 cortante/romo  
 tranchant/mousse  
 acuta/smussa

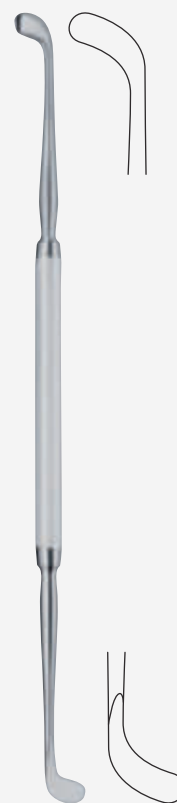

**Pennington**  
 18-411-21

21.5 cm - 8 ½"  
 blunt  
 stumpf  
 romo  
 mousse  
 smussa



**Joseph-Masing**  
 18-412-21

21.5 cm - 8 ½"  
 sharp  
 scharf  
 cortante  
 tranchant  
 acuta



**Masing**

18-413-20 20.8 cm - 8"



**Ballenger-Hajek**

18-414-19 19 cm - 7 ¼"

18-414-22 22 cm - 8 ¾"

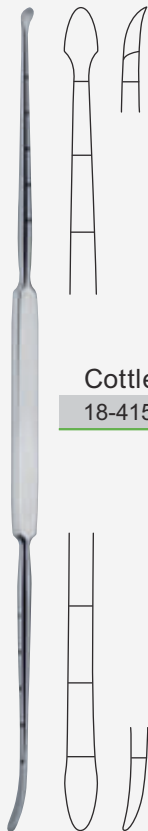

**Cottle**

18-415-22 22 cm - 8 ¾"



**Cottle Modified**

18-416-21 21 cm - 8 ¼"





Boies

18-417-19 19 cm - 7 1/2"

Nasal fracture elevator, blunt  
Nasenfraktur Elevatorium, stumpf  
Elevador para fracturas nasales, romas  
Elévateur pour fractures nasales, mousse  
Elevatore per fratture nasali, smussa



Goldman

18-418-17 17 cm - 6 3/4"

Septum displacer  
Septumfraktur Elevatorium  
Elevador para fracturas del tabique nasal  
Elévateur pour fractures de la cloison nasale  
Elevatore per fratture del setto





Joseph

18-421-19

19 cm - 7 1/2"



18-422-19

19 cm - 7 1/2"



Joseph

18-423-19

19 cm - 7 1/2"

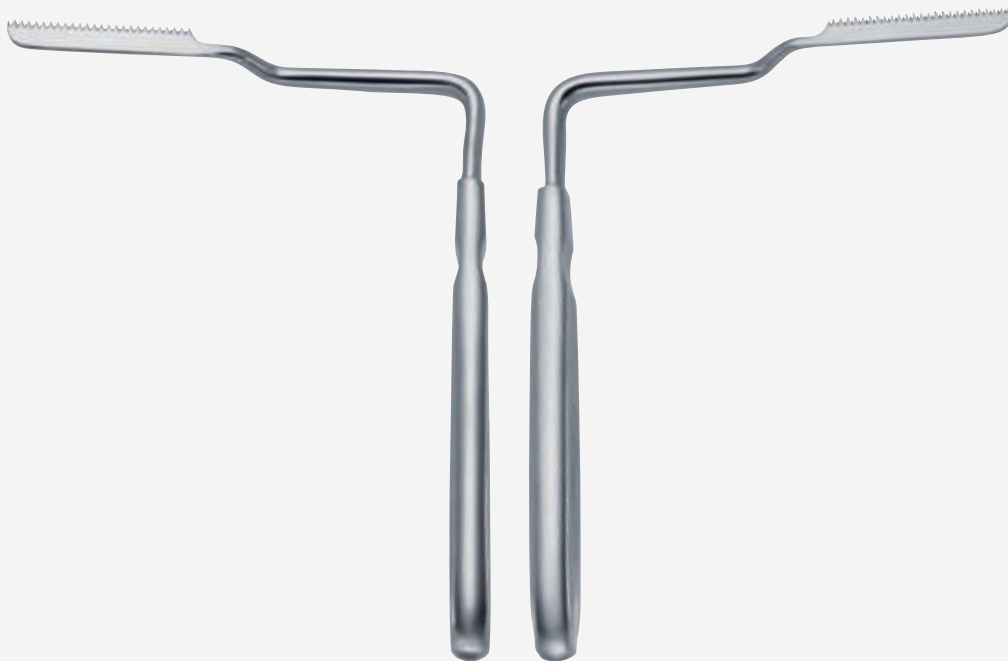

Joseph

18-424-17

17 cm - 7 1/2"

18-425-17

17 cm - 7 1/2"

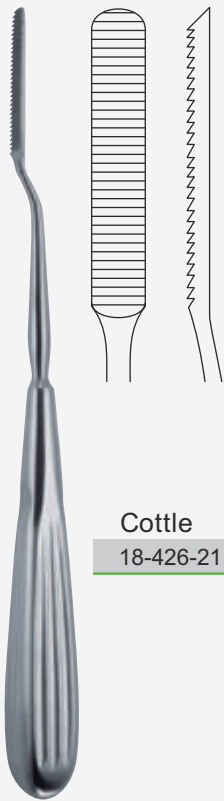

**Cottle**

18-426-21 21 cm - 8 1/4"



**Maltz**

18-427-17

17 cm - 6 3/4"  
 34 mm x 7 mm

drawing cut  
 auf Zug schneidend  
 cortante a tracción  
 tranchant à traction  
 tagliente a trazione



18-428-17

17 cm - 6 3/4"  
 34 mm x 7 mm

pushing cut  
 auf Stoss schneidend  
 cortante a empuje  
 tranchant à impact  
 tagliente a urto



**Aufricht**

18-429-21

21 cm - 8 1/4"

pushing cut  
 auf Stoss schneidend  
 cortante a empuje  
 tranchant à impact  
 tagliente a urto

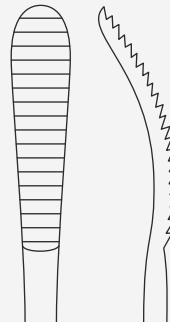

18-430-21

21 cm - 8 1/4"

drawing cut  
 auf Zug schneidend  
 cortante a tracción  
 tranchant à traction  
 tagliente a trazione

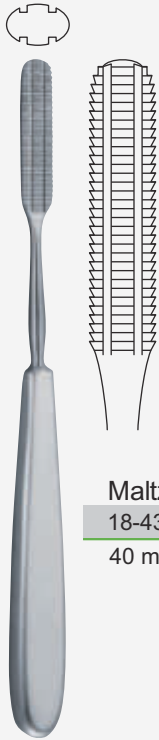

**Maltz**  
18-431-17 17.5 cm - 7"  
40 mm x 9 mm



**Wiener**  
18-432-18 3.5 mm Ø  
18-433-18 3.5 mm Ø 18 cm - 7"

Antrum rasps  
Antrum Raspeln  
Limas para el antrum  
Râpes pour le fosse nasale  
Raspe per antrum



**Gallaher**  
18-434-16 16 cm - 6 ¼"  
18-435-16 16 cm - 6 ¼"  
18-436-16 16 cm - 6 ¼"

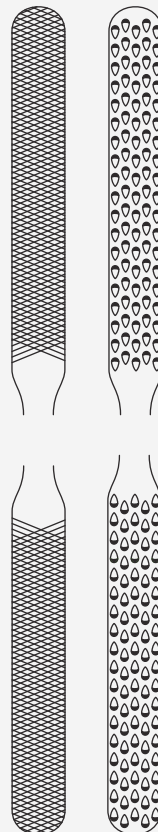

**Fomon**  
18-437-21 21 cm - 8 ¼"

Rasps with tungsten carbide  
 Raspeln mit Hartmetall  
 Limas con carburo de tungsteno  
 Râpes avec inserts de carbure de tungstène  
 Raspe con carburo di tungsteno

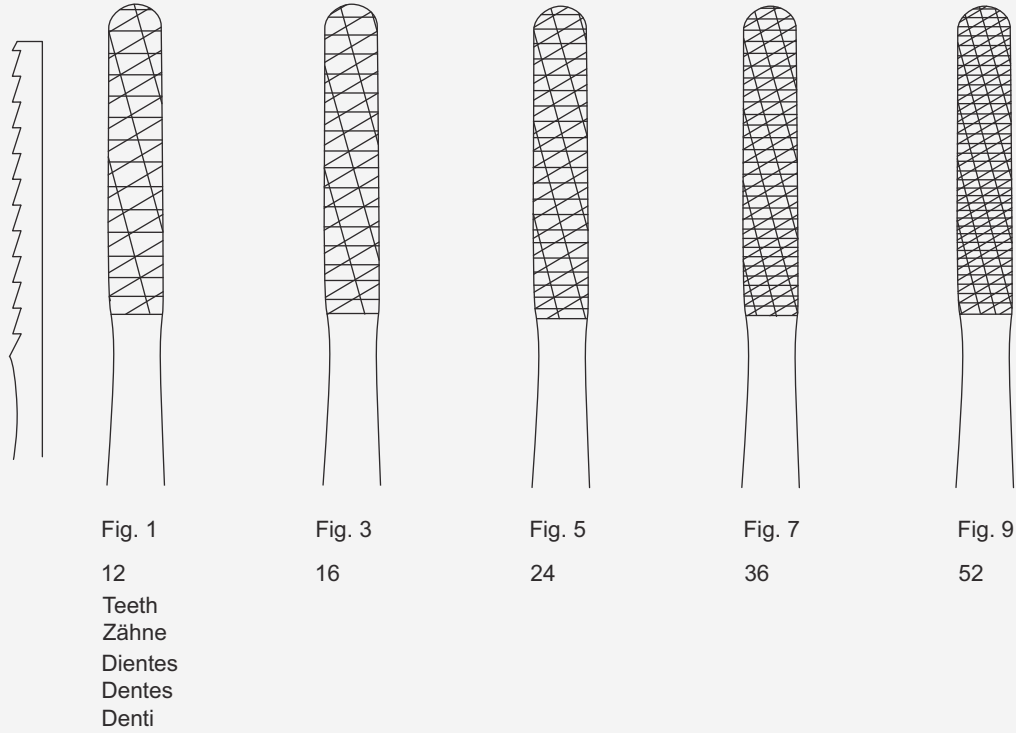

Fomon

- 18-443-20T
- 18-444-20T
- 18-445-20T
- 18-446-20T
- 18-447-20T 20 mm - 8"

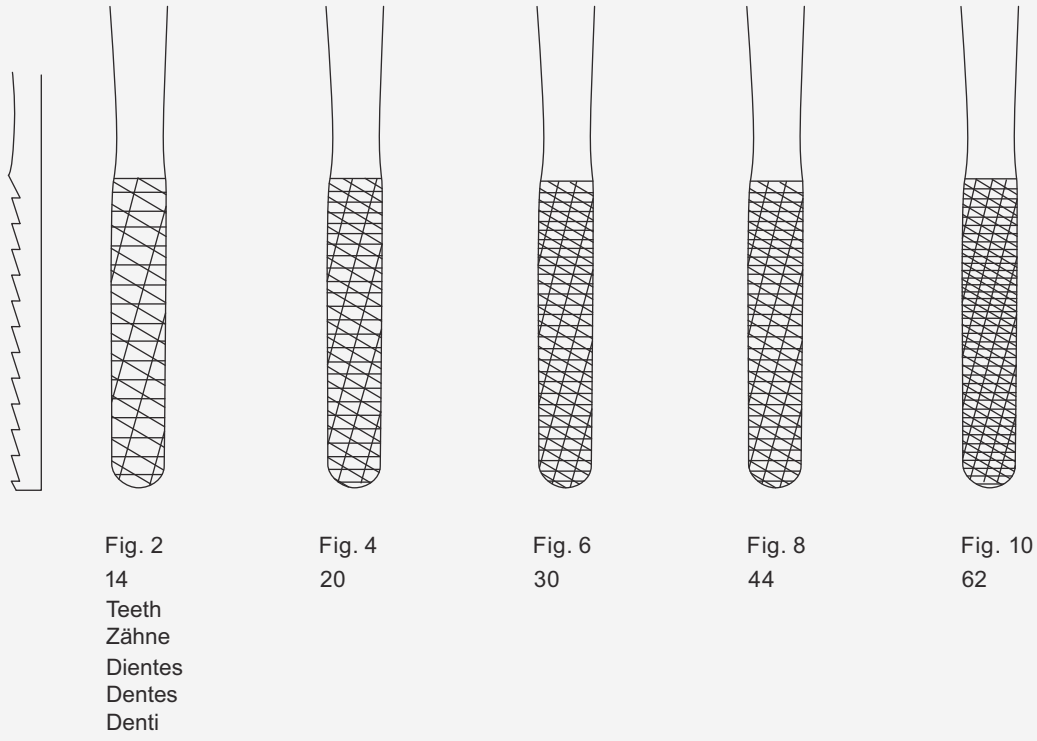



**Bruenings-Brunk**

18-448-19 19 cm - 7 1/2"

Antrum retractor, serrated  
Kieferhöhlenhaken, gezahnt  
Separador para sinus, dentado  
Ecarteur pour sinus maxillaire, dentelé  
Retratore mascellare, dentato



**Ritter-Halle**

18-449-01 2.5 mm Ø

18-449-02 3.0 mm Ø

18-449-03 4.0 mm Ø

16 cm - 6 1/4"

Frontal sinus bougies  
Stirnhöhlen-Dilatatoren  
Dilatadores para el sinus frontal  
Dilatateurs pour le sinus frontal  
Dilatatore per il seno frontale

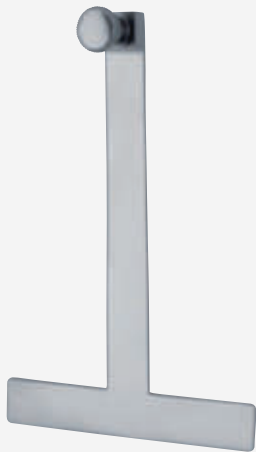

**Cottle**

18-450-12 12 cm - 4 3/4"

Handle  
Griff  
Mango  
Manche  
Manico



**Luca**

18-451-00 7 mm

Guide support for osteotomes  
Führungshilfe für Osteotome  
Soporte de guía para osteótomos  
Support conducteur pour ostéotomes  
Supporto di guida per osteotomi

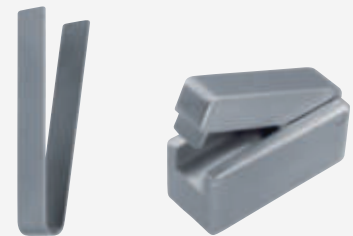

**Cottle**

18-452-00 65 mm x 30 mm 30 mm

Cartilage crusher  
Knorpelquetsche  
Machadora  
Pincers-gouge à cartilage  
Torchio per cartilagine

Septum forceps  
 Septumzangen  
 Pinzas para el tabique nasal  
 Pincas pour la cloison nasale  
 setto forcipe



Cottle-Walsham

18-453-23

straight  
 gerade  
 recta  
 droit  
 rette



18-454-23

left  
 links  
 izquierda  
 à gauche  
 a sinistra



18-455-23

23 cm - 9"

right  
 rechts  
 derecha  
 à droite  
 a destra

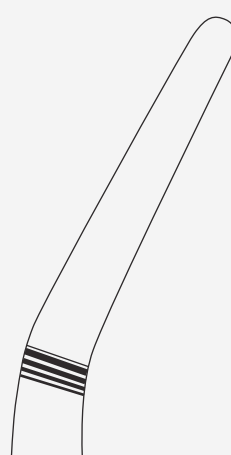

Asch

18-456-23 23 cm - 9"



Middleton-Jansen  
18-457-19 19 cm - 7 1/2"

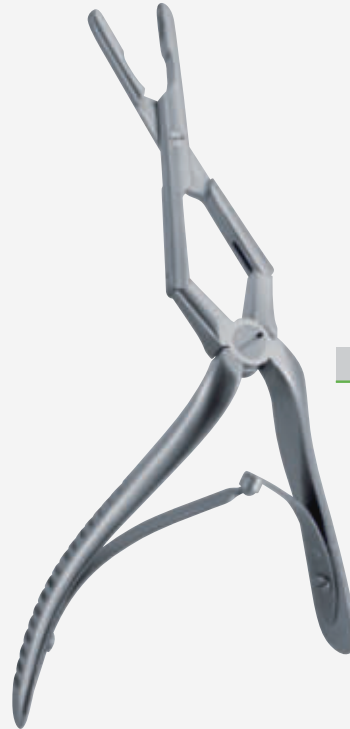

Middleton-Jansen  
18-458-19 19 cm - 7 1/2"



Caplan  
18-459-20 20 cm - 8"

toothed  
gezahnt  
dentado  
dentelée  
dentato



Rubin  
18-460-20 21 cm - 8 1/4"



18-461-00

Protection cap  
Schutzkappe  
Caperuza protectora  
Capuchon protecteur  
Calotta protettiva

Adenoid currettes  
 Ringmesser  
 Cuchillos para vegetaciones adenoides  
 Couteaux à végétations adénoïdes  
 curette adénoïdi



St. Clair-Thomson

18-462-21



18-463-21



18-464-21



18-465-21 21 cm - 8 1/4"



Barnhill

18-466-22

Fig. 1



18-467-22

Fig. 2



18-468-22

Fig. 3



18-469-22 22 cm - 8 3/4"

Fig. 4





Beckmann

18-470-22

straight  
gerade  
recto  
droit  
rette



18-471-22



18-472-22 22 cm - 8 3/4"

18-473-22

curved  
gebogen  
curvo  
courbe  
curve

18-474-22

18-475-22 22 cm - 8 3/4"



18-476-22

straight  
gerade  
recto  
droit  
rette



18-477-22



18-478-22 22 cm - 8 3/4"

18-479-22

curved  
gebogen  
curvo  
courbe  
curve

18-480-22

18-481-22 22 cm - 8 3/4"

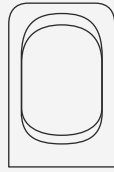
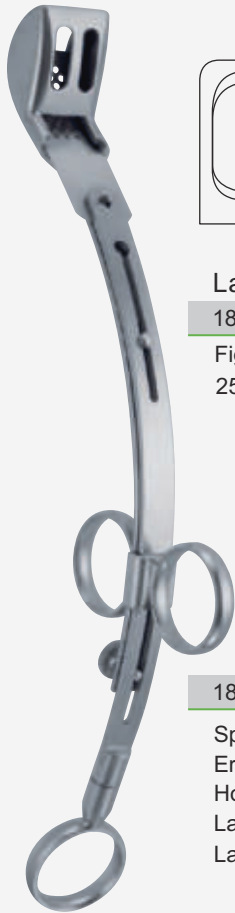

**La Force**  
 18-482-25  
 Fig. 1  
 25 cm - 7"

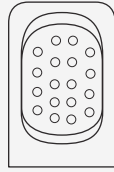

18-483-25

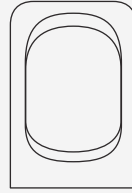

18-484-25  
 Fig. 2  
 25 cm - 7"

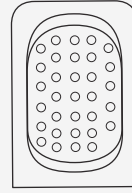

18-485-25

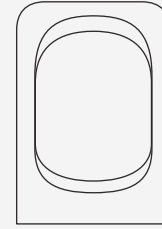

18-486-25  
 Fig. 3  
 25 cm - 7"

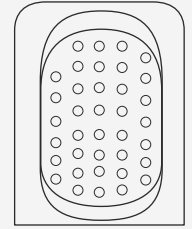

18-487-25

18-488-00

Spare blades  
 Ersatzklingen  
 Hojas de cambio  
 Lames de rechange  
 Lame di ricambio

18-489-00

18-490-00

18-491-00

18-492-00

18-493-00



**Ballenger**

18-494-01

18-494-02

18-494-03

20 cm - 8"  
 straight  
 gerade  
 recto  
 droit  
 rette

18-495-01 x = 3 mm

18-495-02 x = 4 mm

18-495-03 x = 5 mm

20 cm - 8"  
 bayonet  
 bajonett  
 bayoneta  
 baionette  
 baionetta



**Kabierske**

18-496-00

Atomizer, complete  
Pulverbläser, komplett  
Pulvérisateur, complet  
Pulverizador, completo  
Insoffiatore, completo

18-497-00

Spare bottle, 30 ccm  
Ersatzflasche, 30 ccm  
Flacon de rechange, 30 ccm  
Frasco suelto, 30 ccm  
Bottiglia di ricambio, 30 ccm

18-498-00

Valve rubber bulb  
Ventilball  
Poire en caoutchouc avec valve  
Pera de goma con valva  
Pallone in gomma con valva

**Kabierske**

18-499-08

8 cm - 3 ¼"

18-499-11

11 cm - 4 ¼"

18-500-13

13 cm - 5"

Cannula, straight  
Kanüle gerade  
Cánula recta  
Canule droit  
Cannula retta

Cannula, curved  
Kanüle gebogen  
Cánula curva  
Canule courbe  
Cannula curva



**Universal**

18-501-00

Atomizer, complete with movable tube, bottle 30 ccm  
Pulverbläser, komplett mit beweglicher Düse, Flasche 30 ccm  
Pulverizador, completo con tubo móvil, botella 30 ccm  
Pulvérisateur, complet avec tuyère mobile, flacon 30 ccm  
Insoffiatore, completo con ugello mobile, bottiglia 30 ccm



**Politzer**

**18-502-00**

complete with 3 nasal olives  
 komplett mit 3 Nasenoliven  
 completo con 3 olivas nasales  
 complet avec 3 olives nasales  
 completo con 3 olive nasali

**18-503-00** nasal olive 15 mm Ø

**18-504-00** nasal olive 17 mm Ø

**18-505-00** nasal olive 22 mm Ø



**18-503-00**

15 mm Ø  
 Nasal olives  
 Nasenoliven  
 Olivas nasales  
 Olives nasales  
 Olive nasali



**18-504-00**

17 mm Ø



**18-505-00**

22 mm Ø



**18-506-00**

4 mm Ø  
 Ear olive  
 Ohrolive  
 Oliva auricular  
 Olive auriculaire  
 Oliva auricolare

**18-507-00**

15 mm Ø  
 Rubber bulb with connecting nozzle  
 Gummibirne mit Einsteckkonus  
 Pera de goma con cono de conexión  
 Poire en caoutchouc avec embout de raccordement  
 Pera in gomma con cono di connessione

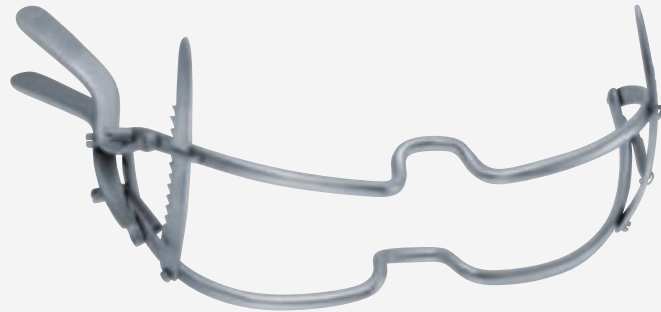

**Whitehead**

18-508-11	11 cm - 4 ¼"
18-508-13	13 cm - 5"
18-508-15	15 cm - 6"



**Jennings**

18-509-09	9 cm - 3 ½"
18-509-11	11 cm - 4 ¼"
18-509-13	13 cm - 5"
18-509-15	15 cm - 6"



**Maunder**

18-510-10 10 cm - 4"

4 mm Ø  
Wood  
Holz  
Madera  
Bois  
Legno



**Heister**

18-511-13 13 cm - 5"

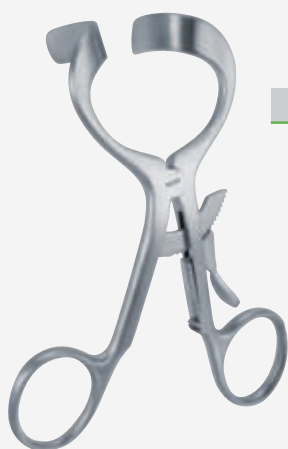

Molt  
18-512-11 11 cm - 4 1/4"

For children  
Für Kinder  
Para niños  
Pour enfants  
Per bambini



Molt  
18-513-14 14 cm - 5 1/2"

For adults  
Für Erwachsene  
Para adultos  
Pour adultes  
Per adulti



Denhart  
18-514-12 12 cm - 4 3/4"



Fergusson-Ackland  
18-515-14 14.5 cm - 5 3/4"



Roser-König  
18-516-16 16 cm - 6 1/4"  
18-516-19 19 cm - 7 1/2"

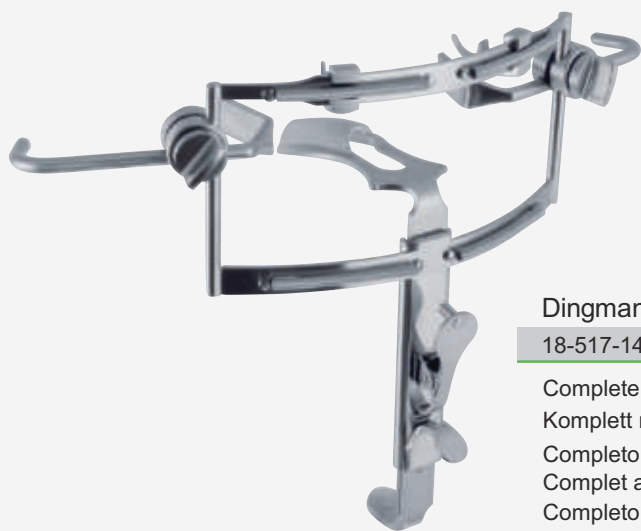

**Dingmann**

18-517-14 14.5 cm - 5 ¾"

Complete with frame, 3 tongue depressors and 2 adjustable lateral blades  
Komplett mit Rahmen, 3 Zungenspateln und 2 beweglichen Seitenvälven  
Completo con bastidor, 3 bajalenguas y 2 valvas laterales ajustables  
Complet avec cadre, 3 abaisse-langues et 2 valves latérales réglables  
Completo con telaio, 3 abassalingua e 2 valve laterali movibili  
18-518-00 - 18-520-00



18-518-00  
55 x 25 mm



18-519-00  
60 x 27 mm



18-520-00  
70 x 30 mm

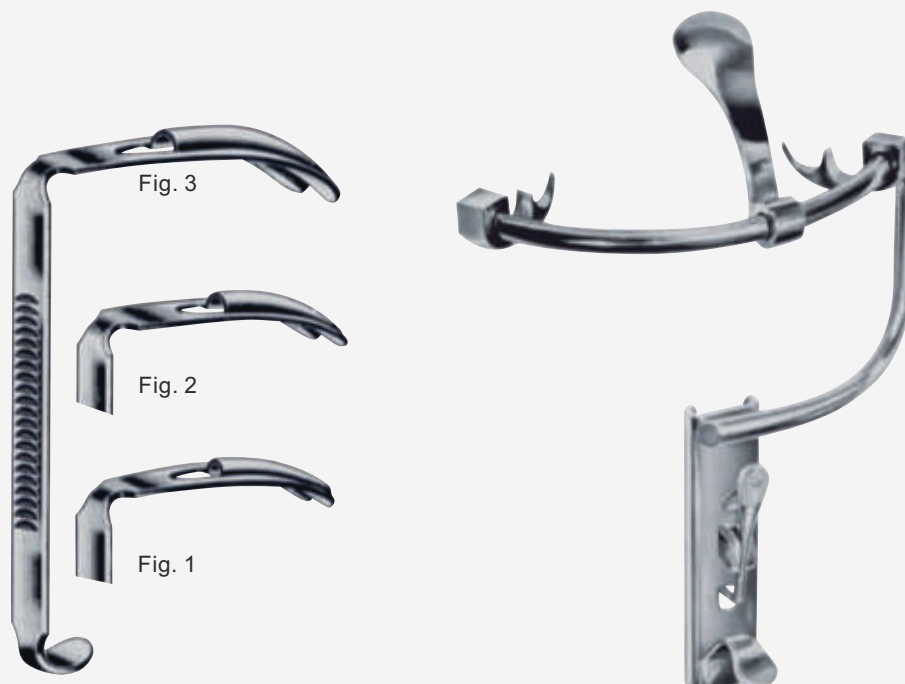

**Kilner-Doughty**

18-521-01

Fig. 1  
 28 mm x 65 mm

18-522-02

Fig. 2  
 32 mm x 75 mm

18-523-03

Fig. 3  
 37 mm x 80 mm

18-524-00

Handle  
 Griff  
 Mango  
 Manche  
 Manico

18-525-00

Complete set consisting:  
 18-521-01, 18-522-02, 18-523-03, 18-524-00

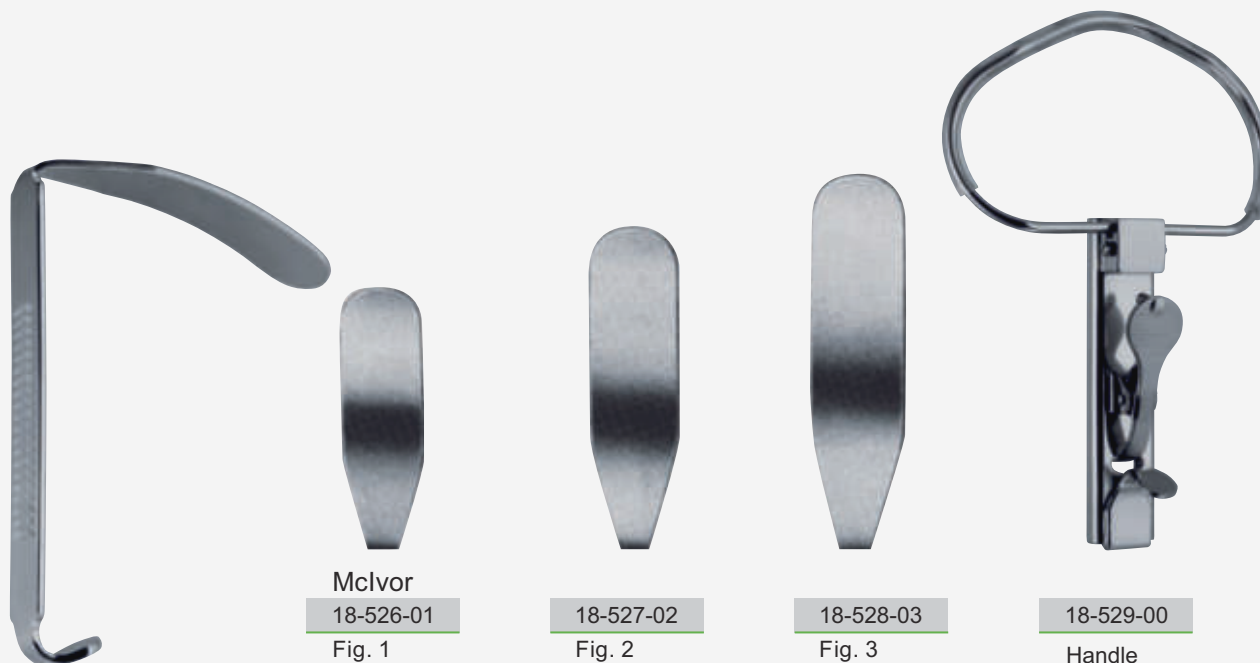

**Mclvor**

18-526-01

Fig. 1  
 23 mm x 70 mm

18-527-02

Fig. 2  
 25 mm x 86 mm

18-528-03

Fig. 3  
 26 mm x 100 mm

18-529-00

Handle  
 Griff  
 Mango  
 Manche  
 Manico

18-530-00

Complete set consisting:  
 18-526-01, 18-527-02, 18-528-03, 18-529-00





**Davis-Boyle**

18-531-01

Fig. 1  
21 mm x 26 mm

18-532-02

Fig. 2  
23 mm x 65 mm

18-533-03

Fig. 3  
24 mm x 80 mm

18-534-04

Fig. 4  
25 mm x 93 mm

18-535-05

Fig. 5  
26 mm x 108 mm

18-536-00

Handle  
Griff  
Mango  
Manche  
Manico

18-537-00

Complete set consisting:  
18-531-01, 18-532-02, 18-533-03, 18-534-04,  
18-535-05, 18-536-00



**Negus**

18-538-01

Fig. 1  
20 mm x 70 mm

18-539-02

Fig. 2  
30 mm x 80 mm

18-540-03

Fig. 3  
33 mm x 95 mm

18-541-00

Handle  
Griff  
Mango  
Manche  
Manico

18-542-00

Complete set consisting:  
18-538-01, 18-539-02, 18-540-03, 18-541-00

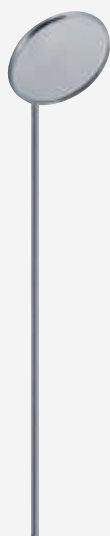

Larygeal

18-543-00	Fig. 00	08 mm Ø
18-543-12	Fig. 0	10 mm Ø
18-543-01	Fig. 1	12 mm Ø
18-543-02	Fig. 2	14 mm Ø
18-543-03	Fig. 3	16 mm Ø
18-543-04	Fig. 4	18 mm Ø
18-543-05	Fig. 5	20 mm Ø
18-543-06	Fig. 6	22 mm Ø
18-543-07	Fig. 7	24 mm Ø
18-543-08	Fig. 8	26 mm Ø
18-543-09	Fig. 9	28 mm Ø
18-543-10	Fig. 10	30 mm Ø



Handle

18-544-10

10 cm - 4"



Larygeal Modified

18-545-11	Fig. 00	08 mm Ø
18-545-12	Fig. 0	10 mm Ø
18-545-01	Fig. 1	12 mm Ø
18-545-02	Fig. 2	14 mm Ø
18-545-03	Fig. 3	16 mm Ø
18-545-04	Fig. 4	18 mm Ø
18-545-05	Fig. 5	20 mm Ø
18-545-06	Fig. 6	22 mm Ø
18-545-07	Fig. 7	24 mm Ø
18-545-08	Fig. 8	26 mm Ø
18-545-09	Fig. 9	28 mm Ø
18-545-10	Fig. 10	30 mm Ø

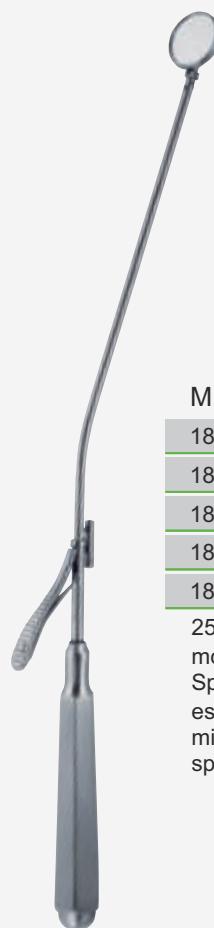

Michel

18-446-01 10 mm Ø

18-446-02 12 mm Ø

18-446-03 14 mm Ø

18-446-04 16 mm Ø

18-446-05 18 mm Ø

25 cm - 9 ¾"

moveable mirror  
 Spiegel beweglich  
 espejeo movable  
 miroir mobile  
 specchio mobile



**Reichert**  
18-547-23 23 cm - 9"

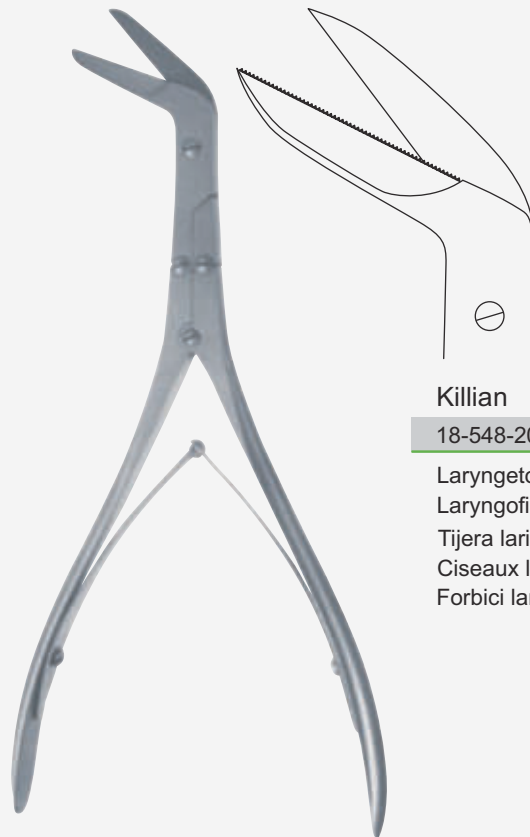

**Killian**  
18-548-20 20 cm - 8"

Laryngotomy scissors  
Laryngofissurschere  
Tijera laringea  
Ciseaux laryngiens  
Forbici laringee

Tonsil snares  
 Tonsillenschnürer  
 Cierra-nudos para amígdalas  
 Serre noeuds pour amygdales  
 lacci delle tonsille

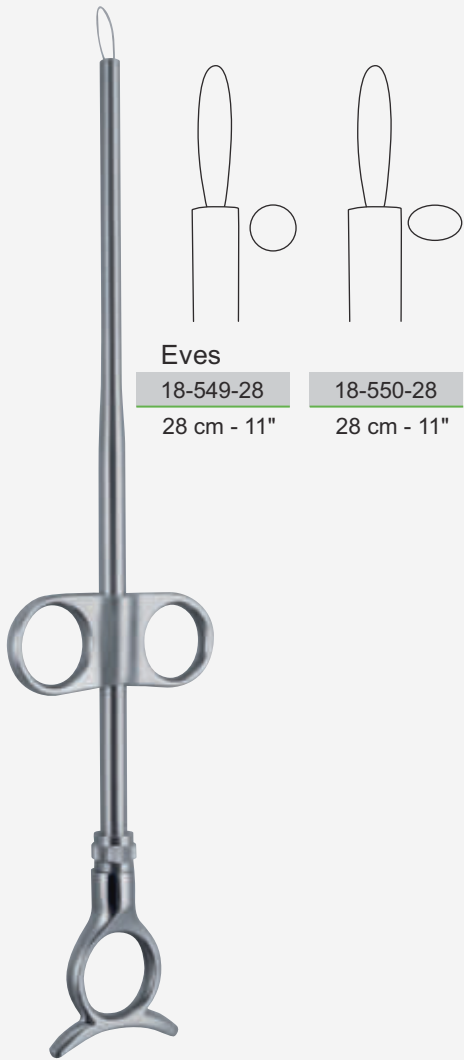

Eves

18-549-28

28 cm - 11"

18-550-28

28 cm - 11"



Eves Modified

18-551-28

28 cm - 11"

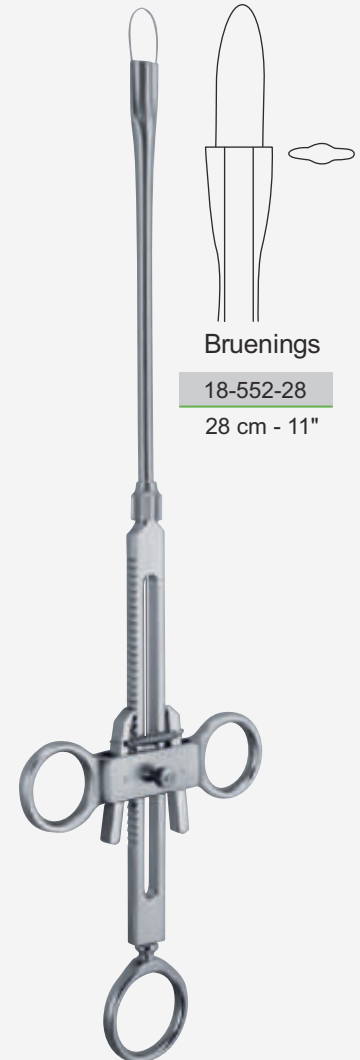

Bruenings

18-552-28

28 cm - 11"



18-553-01 0.3 mm Ø

18-553-02 0.4 mm Ø

10 meter - 33ft.



18-554-01 40 mm

18-554-02 50 mm



package of 100 pieces  
 Packung mit 100 Stück  
 paquet de 100 piezas  
 paquet de 100 pièces  
 pacchetto da 100 pezzi

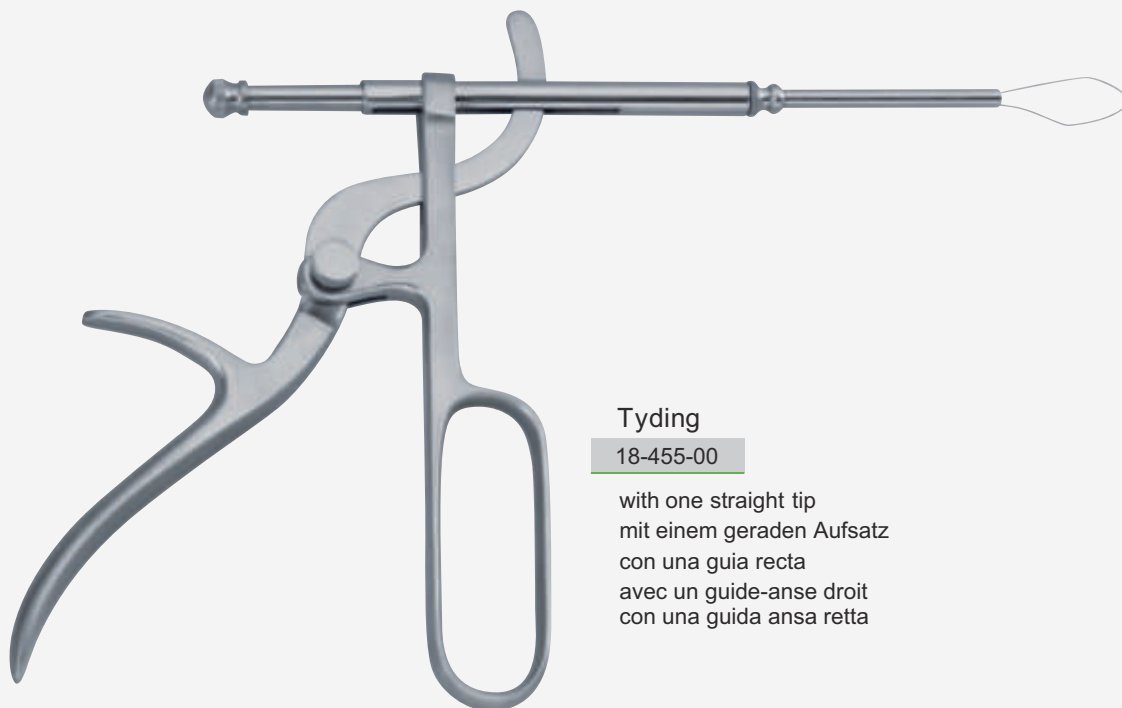

Tyding

18-455-00

with one straight tip  
mit einem geraden Aufsatz  
con una guida recta  
avec un guide-anse droit  
con una guida ansa retta



Tyding

18-456-00 0.4 mm Ø x 10 cm



package of 100 pieces  
Packung mit 100 Stück  
paquete de 100 piezas  
paquet de 100 pièces  
pacchetto da 100 pezzi



**Carpenter**

18-557-25

25 cm - 9 3/4"

Enucleator  
 E nukleator  
 Enucleador para amígdalas  
 Encléateur pour amygdales  
 E nucleatore



**Luniatschek**

18-558-18

18 cm - 7"

Tonsil tampon plugger  
 Tonsillen-Tamponstopfer  
 Porta algodones  
 Porta coton  
 Porta tamponi



**Henke**

18-559-23

23 cm - 9"

Tonsil dissector  
 Tonsillendissektor  
 Disector para amígdalas  
 Dissecteur à amygdales  
 Dissettore tonsillare



**Henke**

18-560-23

23 cm - 9"

Tonsil dissector  
 Tonsillendissektor  
 Disector para amígdalas  
 Dissecteur à amygdales  
 Dissettore tonsillare



**Hurd**

18-561-22

22.5 cm - 8 ¾"

Tonsil dissector

Tonsillendissektor

Disector para amígdalas

Dissecteur à amygdales

Dissettore tonsillare



**Mollison**

18-656-21 21 cm - 8 ¼"

Pillar retractor



**Lewis**

18-562-19 19.5 cm - 7 ¾"

Tonsil screw

Tonsillenschraube

Tira amígdalas

Tire amygdales

Fissa tonsille



**Marschik**

18-563-22 22 cm - 8 ¾"

Tonsil seizing forceps

Tonsillen-Fasspinzette

Pinza prensora de amígdalas

Pince pour saisir les amygdales

Pinza da presa tonsille

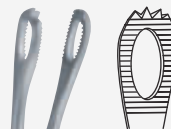

**Blohmke**

18-564-20 20 cm - 8"

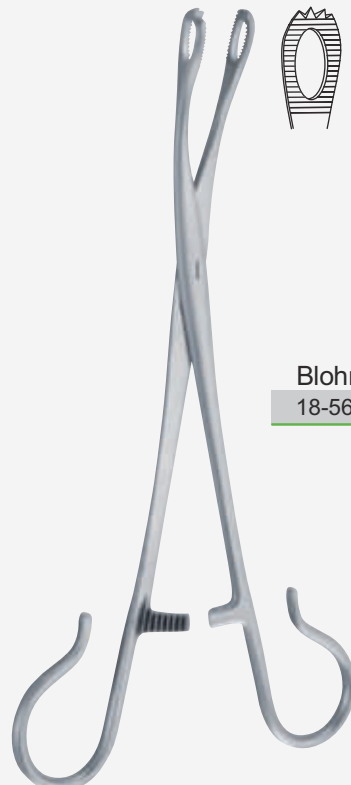



**Colver**

18-565-19

19 cm - 7 1/2"  
 straight  
 gerade  
 recta  
 droit  
 retta

18-466-19

19 cm - 7 1/2"  
 curved  
 gebogen  
 curva  
 courbe  
 curva



**White**

18-567-18

18 cm - 7"

18-567-23

23 cm - 9"

6x5

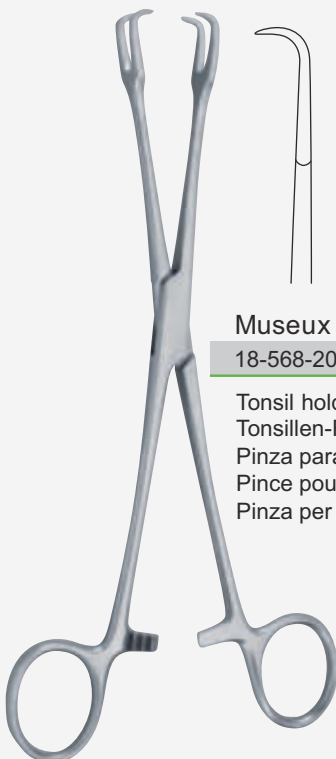

**Museux**

18-568-20

20 cm - 8"

Tonsil holding forceps  
 Tonsillen-Fasszange  
 Pinza para amígdalas  
 Pince pour amygdales  
 Pinza per tonsille

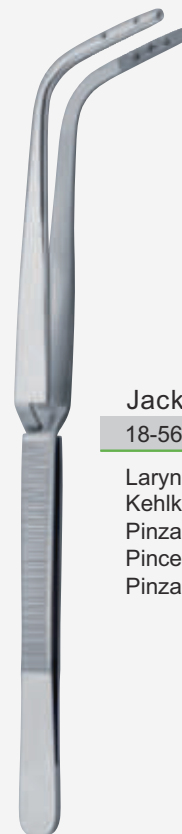

**Jackson**

18-569-22

22 cm - 8 3/4"

Laryngeal forceps  
 Kehlkopfpinzette  
 Pinza laringea  
 Pince laryngienne  
 Pinza laringea



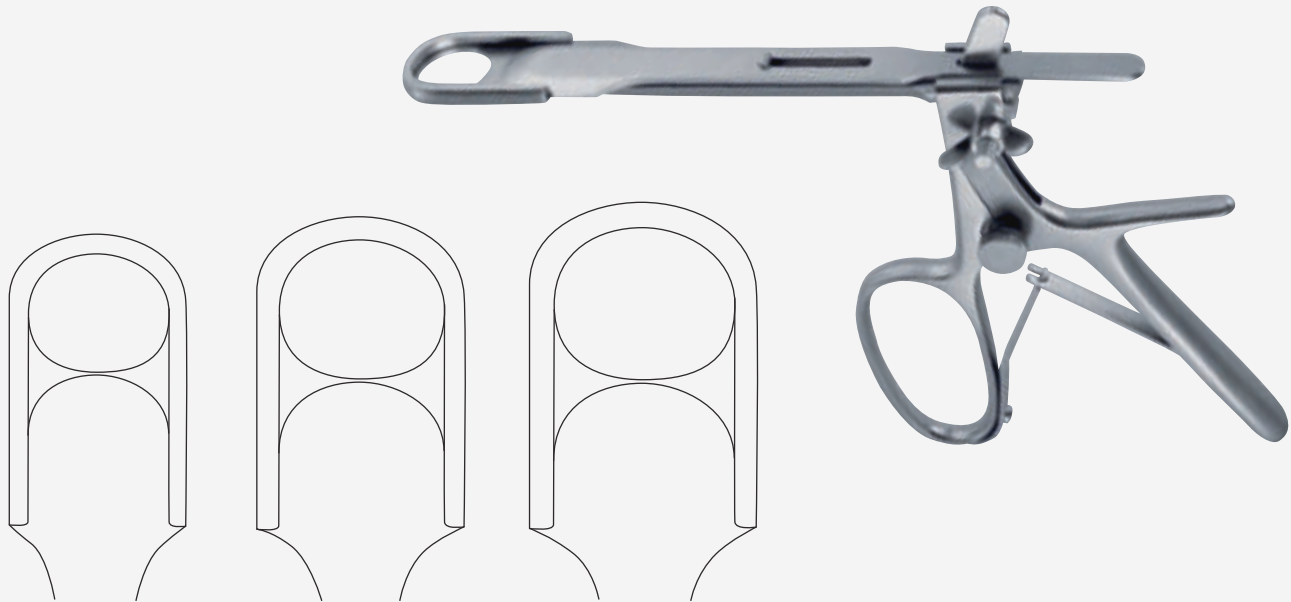

**Sluder-Ballenger**

18-570-01

Fig. 1

18-571-02

Fig. 2

18-572-03

Fig. 3

18-573-00

Handle  
Griff  
Mango  
Manche  
Manico

18-574-00

Complete set consisting:  
18-570-01, 18-571-02, 18-572-03, 18-573-00

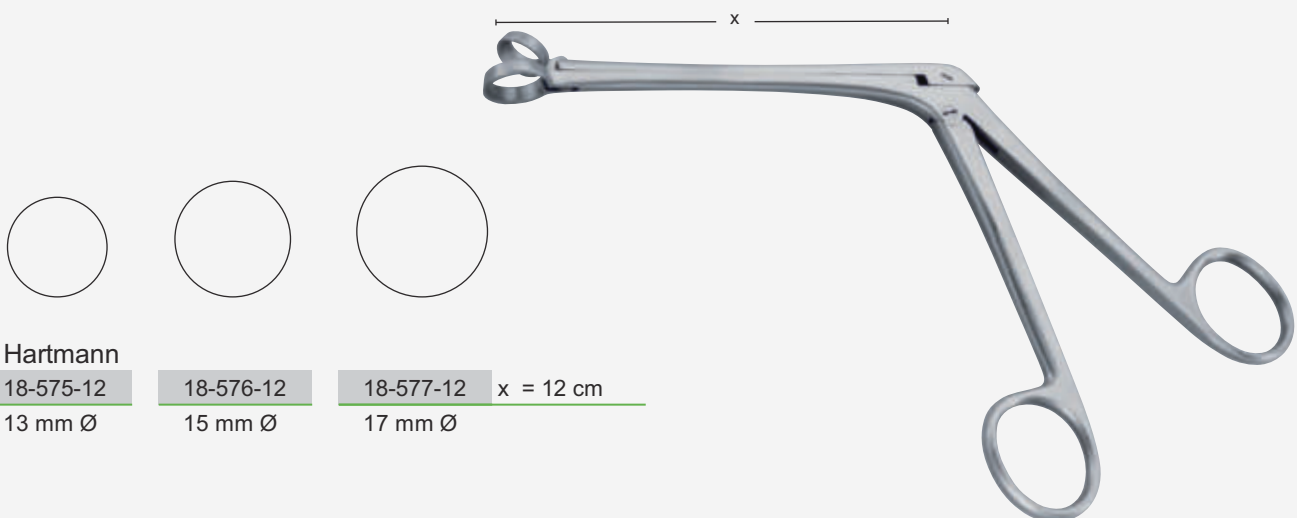

**Hartmann**

18-575-12

13 mm Ø

18-576-12

15 mm Ø

18-577-12 x = 12 cm

17 mm Ø



Laborde

18-578-14 14 cm - 5 1/2"

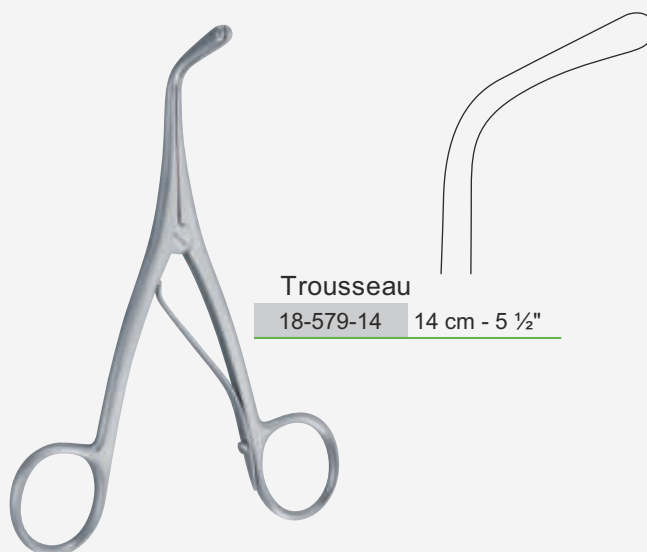

Trousseau

18-579-14 14 cm - 5 1/2"



**Luer Standard**

18-580-00	Fig. 0	4 mm Ø
18-580-01	Fig. 1	5 mm Ø
18-580-02	Fig. 2	6 mm Ø
18-580-03	Fig. 3	7 mm Ø
18-580-04	Fig. 4	8 mm Ø
18-580-05	Fig. 5	9 mm Ø
18-580-06	Fig. 6	10 mm Ø
18-580-07	Fig. 7	11 mm Ø
18-580-08	Fig. 8	12 mm Ø
18-580-09	Fig. 9	13 mm Ø

German silver  
Neusilber  
Plata alemana  
Maillechort  
Argentone



**Uckermann**  
18-581-22  
13 cm - 5"  
10 mm Ø



**Chevalier-Jackson**

18-582-00	Fig. 0	4 mm Ø
18-582-01	Fig. 1	5 mm Ø
18-582-02	Fig. 2	6 mm Ø
18-582-03	Fig. 3	7 mm Ø
18-582-04	Fig. 4	8 mm Ø
18-582-05	Fig. 5	9 mm Ø
18-582-06	Fig. 6	10 mm Ø
18-582-07	Fig. 7	11 mm Ø
18-582-08	Fig. 8	12 mm Ø
18-582-09	Fig. 9	13 mm Ø

German silver  
Neusilber  
Plata alemana  
Maillechort  
Argentone



**Mastin**  
 18-583-17 17 cm - 6 ½"

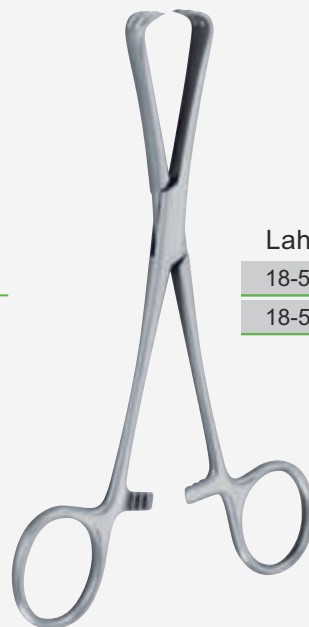

**Lahey**  
 18-584-15 15 cm - 6"  
 18-584-20 20 cm - 8"



**Kocher**  
 18-585-15 18-586-15 15 cm - 6"  
 18-585-16 18-586-16 16 cm - 6 ¼"

with hole  
 mit Loch  
 con orificio  
 avec trou  
 con foro



**Bruenings**

18-587-20	20 cm - 8"
18-587-30	30 cm - 12"
18-587-40	40 cm - 16"
18-587-50	50 cm - 20"
18-587-60	60 cm - 23 1/2"

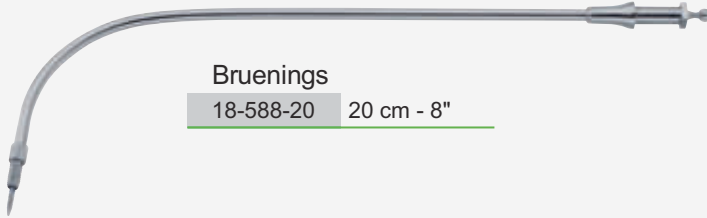

**Bruenings**

18-588-20	20 cm - 8"
-----------	------------



**Huber**  
18-589-00



**Seiffert**  
18-590-00



**Bruenings**  
18-591-00    18-592-00    18-593-00



**Lange**  
18-594-00



**Scheinmann**  
18-595-00



**Fraenkel**  
18-596-00



18-597-01



18-598-01



18-599-02



18-600-02



**Krause**  
18-601-00



**Cordes**  
18-602-00



18-603-00

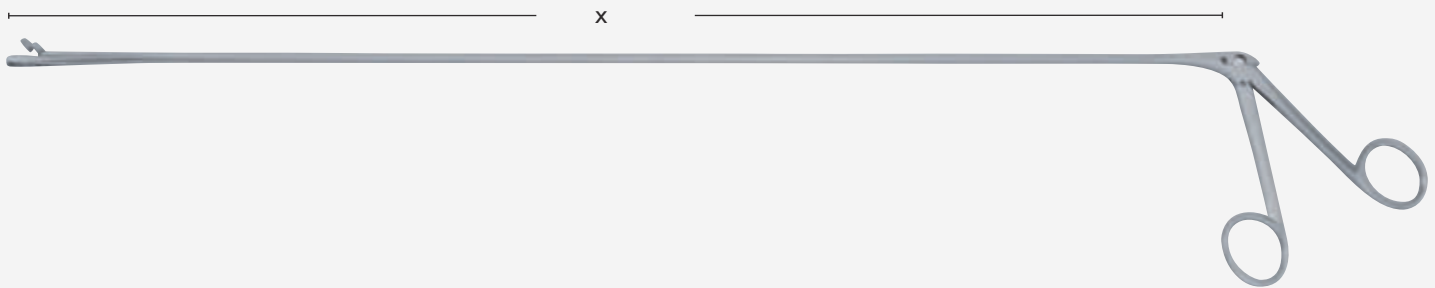

Chevalier-Jackson

18-675-30
18-675-40
18-675-50
18-675-60



18-676-30
18-676-40
18-676-50
18-676-60



18-677-30
18-677-40
18-677-50
18-677-60



18-678-30	x = 30 cm - 12"
18-678-40	x = 40 cm - 16"
18-678-50	x = 50 cm - 20"
18-678-60	x = 60 cm - 23 ½"



Chevalier-Jackson

18-604-30
18-604-40
18-604-50
18-604-60



18-605-30
18-605-40
18-605-50
18-605-60



18-606-30	x = 30 cm - 12"
18-606-40	x = 40 cm - 16"
18-606-50	x = 50 cm - 20"
18-606-60	x = 60 cm - 23 ½"

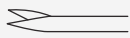
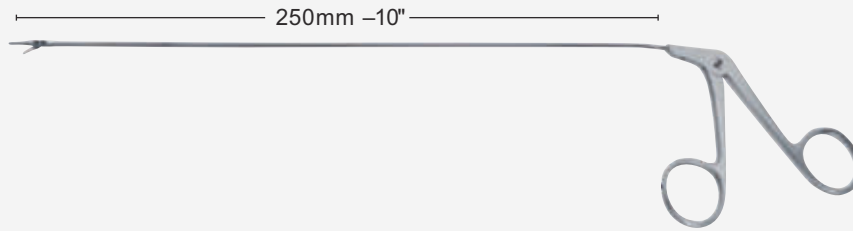

Gotan

18-607-00

Scissors  
Scheren  
Tijeras  
Ciseaux  
Forbice

straight  
gerade  
recta  
droit  
retta



18-608-00

straight horizontal  
gerade horizontal  
recta horizontal  
droit horizontal  
retta orizzontale



18-609-00

angled up horizontal  
aufgebogen horizontal  
curvada arriba horizontal  
coudé en haut coupe horizontal  
curvata in alto orizzontale



18-610-00

curved right  
rechts gebogen  
curvada a derecha  
courbe à droite  
curva a destra



18-611-00

curved left  
links gebogen  
curvada a izquierda  
courbe à gauche  
curva a sinistra



18-612-00

angled up  
aufgebogen  
curvada arriba  
coudé en haut  
curvata in alto



18-613-00

Alligator forceps  
Alligatorzangen  
Pinzas cocodrilo  
Pincés crocodile  
Pinze cocodrillo

straight, serrated  
gerade, gerieft  
recta, estriada  
droit, strié  
retta, zigrinata



18-614-00

straight horizontal  
gerade horizontal  
recta horizontal  
droit horizontal  
retta orizzontale



18-615-00

angled up horizontal  
aufgebogen horizontal  
curvada arriba horizontal  
coudé en haut coupe horizontal  
curvata in alto orizzontale



18-616-00

curved right  
rechts gebogen  
curvada a derecha  
courbe à droite  
curva a destra



18-617-00

curved left  
links gebogen  
curvada a izquierda  
courbe à gauche  
curva a sinistra



18-618-00

Cup shaped forceps  
Löffelzangen  
Pinzas cureta  
Pincés currettes  
Pinze a cucchaio

straight  
gerade  
recta  
droit  
retta

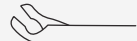

18-619-00

angled up  
aufgebogen  
curvada arriba  
coudé en haut  
curvata in alto



18-620-00

angled up horizontal  
aufgebogen horizontal  
curvada arriba horizontal  
coudé en haut coupe horizontal  
curvata in alto orizzontale

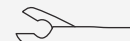

18-621-00

curved right  
rechts gebogen  
curvada a derecha  
courbe à droite  
curva a destra



18-622-00

curved left  
links gebogen  
curvada a izquierda  
courbe à gauche  
curva a sinistra

○ 2.5 mm









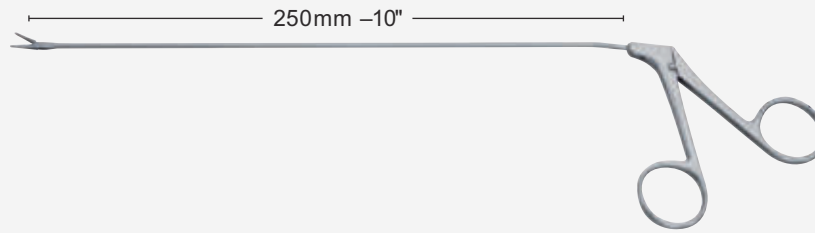



18-623-00

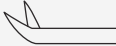

○ 3 x 5 mm

Cup shaped forc. oval  
Löffelzange oval  
Pinza cureta oval  
Pince curette ovale  
Pinza a cucchaio ovale



						
	<b>Helmet</b>					
	<b>18-624-00</b>	<b>18-625-00</b>	<b>18-626-00</b>	<b>18-627-00</b>	<b>18-628-00</b>	<b>18-629-00</b>
Scissors	straight	straight horizontal	angled up horizontal	curved right	curved left	angled up
Scheren	gerade	gerade horizontal	aufgebogen horizontal	rechts gebogen	links gebogen	aufgebogen
Tijeras	recta	recta horizontal	curvada arriba horizontal	curvada a derecha	curvada a izquierda	curvada arriba
Ciseaux	droit	droit horizontal	coudé en haut coupe horizontal	courbe à droite	courbe à gauche	coudé en haut
Forbice	retta	retta orizzontale	curvata in alto orizzontale	curva a destra	curva a sinistra	curvata in alto

					
	<b>18-630-00</b>	<b>18-631-00</b>	<b>18-632-00</b>	<b>18-633-00</b>	<b>18-634-00</b>
Alligator forceps	straight	straight horizontal	angled up horizontal	curved right	curved left
Alligatorzangen	gerade	gerade horizontal	aufgebogen horizontal	rechts gebogen	links gebogen
Pinzas cocodrilo	recta	recta horizontal	curvada arriba horizontal	curvada a derecha	curvada a izquierda
Pincas crocodile	droit	droit horizontal	coudé en haut coupe horizontal	courbe à droite	courbe à gauche
Pinze cocodrillo	retta	retta orizzontale	curvata in alto orizzontale	curva a destra	curva a sinistra

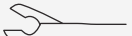
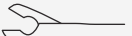
						○ 2.5 mm
	<b>18-635-00</b>	<b>18-636-00</b>	<b>18-637-00</b>	<b>18-638-00</b>	<b>18-639-00</b>	
Cup shaped forceps	straight	angled up	angled up horizontal	curved right	curved left	
Löffelzangen	gerade	aufgebogen	aufgebogen horizontal	rechts gebogen	links gebogen	
Pinzas cureta	recta	curvada arriba	curvada arriba horizontal	curvada a derecha	curvada a izquierda	
Pincas currettes	droit	coudé en haut	coudé en haut coupe horizontal	courbe à droite	courbe à gauche	
Pinza a cucchaio	retta	curvata in alto	curvata in alto orizzontale	curva a destra	curva a sinistra	

	<b>18-640-00</b> ○ 3 x 5 mm
Cup shaped forceps, oval	
Löffelzange, oval	
Pinza cureta, oval	
Pince curette, ovale	
Pinza a cucchaio ovale	



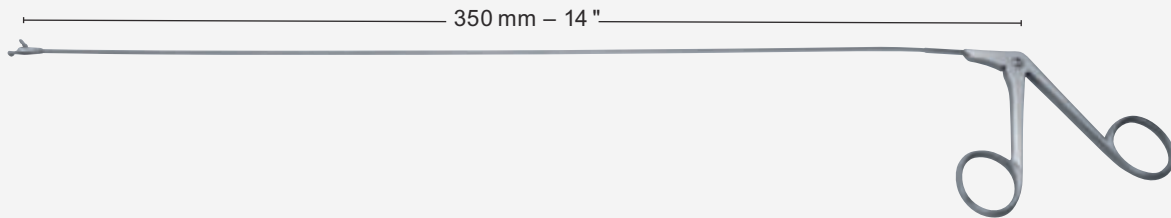

**Bukshire**  
18-641-00

Grasping forceps  
Fasszange  
Pinza agarre  
Pince à saisir  
Pinza da presa

straight, serrated  
gerade, gerieft  
recta, estriada  
droit, striée  
retta, zigrinata



18-642-00

straight, fenestrated  
gerade, gefenstert  
recta, fenestrada  
droit, fenêtrée  
retta, fenestrata

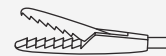

18-643-00

straight  
gerade  
recta  
droits  
retta



18-644-00

Cup shaped forceps  
Löffelzangen  
Pinzas cureta  
Pincas curettes  
Pinze a cucchaio

straight  
gerade  
recta  
droit  
retta



18-645-00

angled up  
aufgebogen  
curvada arriba  
coudée en haut  
curvata in alto



18-646-00

angled up horizontal  
aufgebogen horizontal  
curvada arriba horizontal  
coudée en haut  
curvata in alto orizzontale



18-647-00

curved right  
rechts gebogen  
curvada a derecha  
courbe à droite  
curva a destra



18-648-00

curved left  
links gebogen  
curvada a izquierda  
courbe à gauche  
curva a sinistra

○ 3 mm



18-649-00

Cup shaped forceps  
Löffelzangen  
Pinzas cureta  
Pincas curettes  
Pinze a cucchaio

2 mm x 5 mm  
straight  
gerade  
recta  
droit  
retta



18-650-00

3 mm x 5 mm  
straight  
gerade  
recta  
droit  
retta



18-651-00

Universal forceps  
Universalzange  
Pinza universal  
Pince universelle  
Pinza universale

straight  
gerade  
recta  
droit  
retta

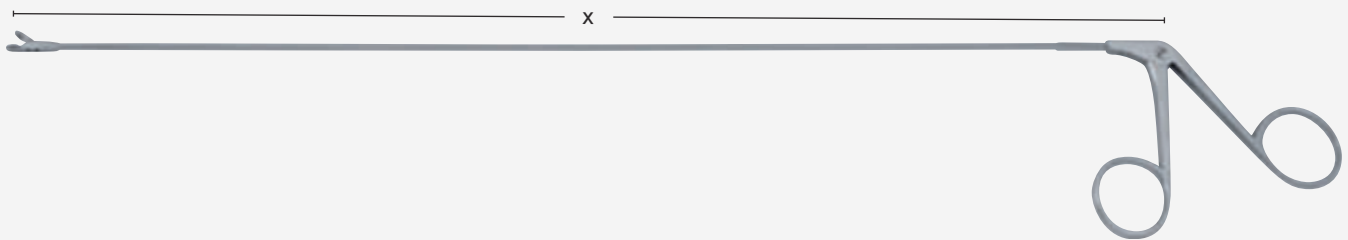

**Gibtek**

18-652-40	x = 40 cm - 16"
18-652-50	x = 50 cm - 20"
18-652-60	x = 60 cm - 23 1/2"

Punch forceps, straight  
 Tumorzange, gerade  
 Pinza para tumores, recta  
 Pince pour tumeurs, droit  
 Pinza per tumori, retta



18-653-40
18-653-50
18-653-60

Grasping forceps  
 Fasszangen  
 Pinzas agarre  
 Pincas à saisir  
 Pinze da presa

straight, serrated  
 gerade, gerieft  
 recta, estriada  
 droit, striée  
 retta, zigrinata



18-654-40
18-654-50
18-654-60

straight, fenestrated  
 gerade, gefenstert  
 recta, fenestrada  
 droit, fenêtrée  
 retta, finestra



18-655-40	x = 40 cm - 16"
18-655-50	x = 50 cm - 20"
18-655-60	x = 60 cm - 23 1/2"

straight  
 gerade  
 recta  
 droit  
 retta



**Makson**

18-656-40

18-656-50

18-656-60

4 mm  
straight  
gerade



18-657-40

18-657-50

18-657-60

4 mm  
angled up  
aufgebogen  
curvada arriba  
coudée en haut  
curvata in alto



18-658-40

18-658-50

18-658-60

4 mm  
angled up horizontal  
aufgebogen horizontal  
curvada arriba horizontal  
coudée en haut coupe horizontalement  
curvata orizzontalmente

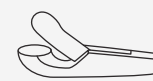

18-659-40

18-659-50

18-659-60

4 mm  
curved right  
rechts gebogen  
curvada a derecha  
courbe à droite  
curva a destra

Cup shaped forceps  
Löffelzangen  
Pinzas cureta  
Pinces à curette  
Pinze a cucchaio

x = 40 cm - 16"

x = 50 cm - 20"

x = 60 cm - 23 ½"

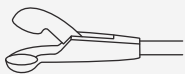

18-660-40

18-660-50

18-660-60

4 mm  
curved left  
links gebogen  
curvada a izquierda  
courbe à gauche  
curva a sinistra

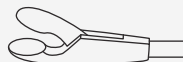

18-661-40

18-661-50

18-661-60

3 mm x 4 mm  
straight  
gerade  
recta  
droit  
retta



18-662-40

18-662-50

18-662-60

4 mm x 6 mm  
straight  
gerade  
recta  
droit  
retta



18-663-40

18-663-50

18-663-60

4 mm x 8 mm  
straight  
gerade  
recta  
droit  
retta

Cup shaped forceps  
Löffelzangen  
Pinzas cureta  
Pinces mors currettes  
Pinze a cucchaio

x = 40 cm - 16"

x = 50 cm - 20"

x = 60 cm - 23 ½"



18-664-40 x = 40 cm - 16"

18-664-50 x = 50 cm - 20"

18-664-60 x = 60 cm - 23 ½"

Universal forceps  
Universalzange  
Pinza universal  
Pince universelle  
Pinza universale

straight  
gerade  
recta  
droit  
retta

Laryngeal polypus forceps  
 Kehlkopfpolypenzangen  
 Pinzas para pólipos laringeos  
 Pincas à polypes laryngiens  
 Pinze polipi laringei

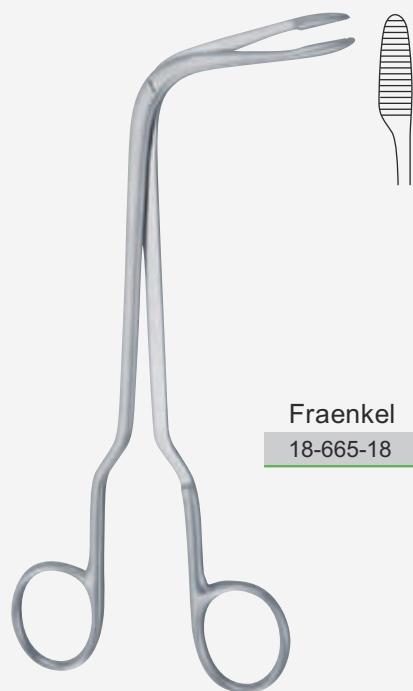

**Fraenkel**

18-665-18 18 cm - 7"



**Jurasz**

18-666-23

right  
 rechts  
 a derecha  
 à droite  
 verso destra

18-667-23 23 cm - 9"

left  
 links  
 a izquierda  
 à gauche  
 verso sinistra



18-668-00

downwards  
 nach unten  
 hacia abajo  
 vers le bas  
 verso basso



18-669-00

upwards  
 nach oben  
 hacia arriba  
 vers le haut  
 verso alto

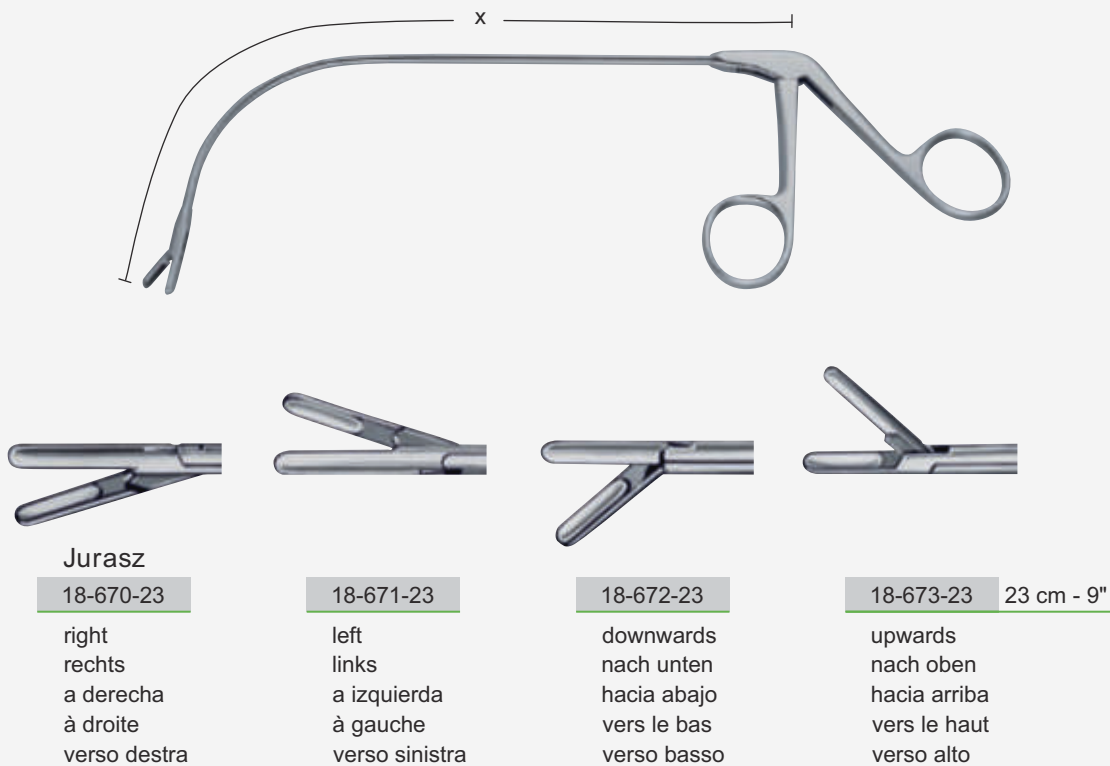

Laryngeal polypus forceps  
Kehlkopfpolypenzangen  
Pinzas para pólipos laringeos  
Pinces à polypes laryngiens  
Pinze polipi laringei

comed  
operate better with us

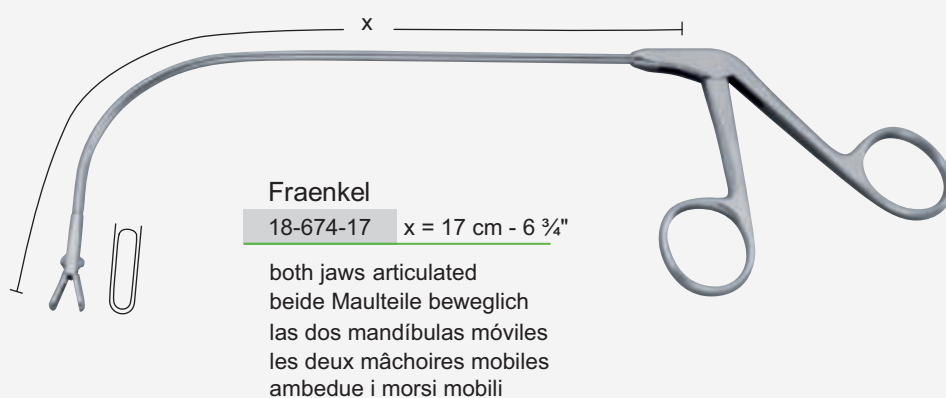



Autopsy  
Autopsie  
Autopsia  
Autopsie  
Autopsia



Hamy

19-101-27

27 cm - 10 $\frac{3}{4}$ "



Brunetti

19-102-28

28 cm - 11"

19-103-28

28 cm - 11"



Rachiotome

19-104-22

22 cm - 8 $\frac{3}{4}$ "



Chisel

19-105-13

13 cm - 5"

x = 23 mm

Chisels for opening the spinal column  
Meißel zur Öffnung der Wirbelsäule  
Cinceles para abrir la columna vertebral  
Burins pour ouvrir la colonne vertebrale  
Scalpelli per aprire la colonna vertebrale





Magnifying Mirror  
19-127-00  
Small



Magnifying Mirror  
19-128-00  
Medium



Magnifying Mirror  
19-129-00  
Large

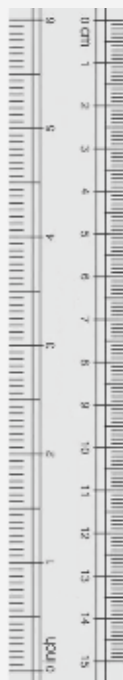

Ruler - Plastic  
19-130-00  
15 cm



Pipette Filler  
19-131-00  
Disposable



**Virchow**  
 19-106-00

Skull breaker  
 Schädelspalter  
 Cincel rompe craneo  
 Burin casse-crâne  
 Apri cranio



**Psy**  
 19-107-10

10 cm - 4"  
 Muscle hook  
 Muskelhaken  
 Gancho muscular  
 Crochet musculaire  
 Uncino muscolare



**Chain Hook**  
 19-116-00

10 cm - 4"



**Lionel**  
 19-108-16

16 cm - 6 1/4"  
 10 mm x 50 mm



**Dissecting Scissors**

19-117-11	19-118-11	11 cm - 4 1/4"
19-119-12	19-120-12	12.5 cm - 5"
19-121-15	19-122-15	15 cm - 6"

Straight

Curved



Piny

19-109-13 Sharp/straight

19-109-01 Sharp/curved

19-109-02 Blunt/straight

19-109-03 Blunt/curved

13.5 cm - 5 1/4"

Stainless steel



19-110-13

13.5 cm - 5 1/4"

Arrow point

Stainless steel



19-114-01 Straight

19-115-01 Curved

19-114-03 Arrow point/straight

13.5 cm - 5 1/4"

Aluminium



19-114-02 Straight

19-115-02 Curved

19-114-04 Arrow point/straight

13.5 cm - 5 1/4"

Wooden handle



19-114-00 Sharp/straight

19-115-00 Sharp/curved

19-114-05 Blunt/straight



19-115-05 Blunt/curved















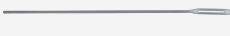

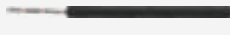
19-114-06 Arrow point/straight

13.5 cm - 5 1/4"

Plastic

Set of instruments for autopsy  
 Autopsie-Besteck  
 Juego de instrumentos para autopsia  
 Set à autopsie  
 Set di strumenti per l'autopsia









	Item No.	Description		Item No.	Description
	19-111-00	Set of 14 pieces consisting of:		09-812-14	Mayo Hegar needle holder 14 cm
	05-901-14	Dressing forceps serrated 14.5 cm		02-377-14	Butterfly retractor
	05-923-14	Dressing forceps toothed 14.5 cm		02-375-14	Probe with eye
	04-181-14	Operating scissors straight 14.5 cm		19-116-00	Chain hook
	04-190-14	Operating scissors curved 14.5 cm		03-505-03	Scalpel handle No. 3
	06-239-14	Kelly forceps straight 14 cm		03-502-04	Scalpel handle No. 4
	06-240-14	Kelly forceps curved 14 cm			
	08-888-00	Farabauf retractor 12 cm			
	06-214-12	Mosquito forceps straight 12.5 cm			

	Item No. <b>19-112-00</b>	Description Set of 16 pieces consisting of:		Item No. <b>09-812-14</b>	Description Mayo Hegar needle holder 14 cm
	Item No. <b>05-901-14</b>	Description Dressing forceps serrated 14.5 cm		Item No. <b>02-377-14</b>	Description Butterfly retractor
	Item No. <b>05-923-14</b>	Description Dressing forceps toothed 14.5 cm		Item No. <b>02-375-14</b>	Description Probe with eye
	Item No. <b>04-181-14</b>	Description Operating scissors straight 14.5 cm		Item No. <b>19-114-00</b>	Description Dissecting needle straight
	Item No. <b>04-190-14</b>	Description Operating scissors curved 14.5 cm		Item No. <b>19-115-00</b>	Description Dissecting needle curved
	Item No. <b>06-239-14</b>	Description Kelly forceps straight 14 cm		Item No. <b>19-116-00</b>	Description Chain hook
	Item No. <b>06-240-14</b>	Description Kelly forceps curved 14 cm		Item No. <b>03-505-03</b>	Description Scalpel handle No. 3
	Item No. <b>08-888-00</b>	Description Farabauf retractor 12 cm		Item No. <b>03-502-04</b>	Description Scalpel handle No. 4
	Item No. <b>06-214-12</b>	Description Mosquito forceps straight 12.5 cm			

Microscopic instrument set in wooden case  
 Mikroskopier-Besteck in Holzetui  
 Estuche de microscopia en caja de madera  
 Trousse pour microscopie, en boîte en bois  
 Microscopico set di strumenti nel caso di legno







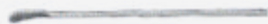





	Item No.	Description
	19-113-00	Set of 10 pieces consisting of:
	19-119-12	Dissecting scissor straight 12.5 cm
	19-120-12	Dissecting scissors curved 12.5 cm
	19-114-01	Dissecting needle straight - Aluminium
	19-115-01	Dissecting needle curved - Aluminium
	05-901-14	Dressing forceps serrated 14.5 cm
	19-123-00	Specula - Aluminium
	03-505-03	Scalpel handle No. 3
	03-502-04	Scalpel handle No. 4

	Item No.	Description
	05-976-12	Iris dressing forceps 12.5 cm
	05-177-11	Micro Forceps 11 cm

	Item No.	Description
	19-124-00	Set of 10 pieces consisting of:
	03-505-03	Scalpel handle No. 3
	03-502-04	Scalpel handle No. 4
	04-181-14	Operating scissors straight 14.5 cm
	04-190-14	Operating scissors curved 14.5 cm
	05-177-11	Micro Forceps 11 cm
	19-114-01	Dissecting needle straight - Aluminium
	19-115-01	Dissecting needle curved - Aluminium
	05-901-14	Dressing forceps serrated 14.5 cm

	Item No.	Description
	05-976-14	Iris dressing forceps 14 cm
	19-123-00	Specula Aluminium

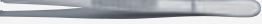
Microscopic instrument set in wooden case  
 Mikroskopier-Besteck in Holzetui  
 Estuche de microscopia en caja de madera  
 Trousse pour microscopie, en boîte en bois  
 Microscopico set di strumenti nel caso di legno



	Item No.	Description		Item No.	Description
	19-125-00	Set of 13 pieces consisting of:		06-215-12	Mosquito forceps curved 12.5 cm
	03-505-03	Scalpel handle No. 3		09-812-14	Mayo Hegar needle holder 14 cm
	03-502-04	Scalpel handle No. 4		02-377-14	Butterfly retractor
	04-181-14	Operating scissors straight 14.5 cm		02-375-14	Probe with eye
	04-771-14	Lister bandage scissors 14 cm		03-512-20	Scalpel blade No. 20 (2 pcs)
	05-901-14	Dressing forceps non toothed 14.5 cm			
	05-924-14	Dressing forceps 1x2 teeth 14.5 cm			
	19-116-00	Chain hook			
	06-214-12	Mosquito forceps straight 12.5 cm			



	Item No.	Description		Item No.	Description
	19-126-00	Set of 12 pieces consisting of:		19-109-13	Dissecting needle stainless steel straight
	03-505-03	Scalpel handle No. 3		19-110-13	Mayo Hegar needle holder 14 cm
	03-502-04	Scalpel handle No. 4		19-109-03	Butterfly retractor
	04-181-14	Operating scissors straight 14.5 cm		03-501-03	Probe with eye
	09-812-14	Mayo Hegar needle holder 14 cm			
	05-915-12	Adson forceps non toothed 12 cm			
	05-901-14	Dressing forceps non toothed 14.5 cm			
	03-512-20	Scalpel blade No. 20 (2 pcs)			
	04-688-11	Iris scissors straight 11.5 cm			

Microscopic instrument set in wooden case  
 Mikroskopier-Besteck in Holzetui  
 Estuche de microscopia en caja de madera  
 Trousse pour microscopie, en boîte en bois  
 Microscopico set di strumenti nel caso di legno

	Item No.	Description
	19-127-00	Set of 7 pieces consisting of:
	05-976-15	Iris dressing forceps 12.5 cm
	19-130-00	Ruler 15 cm plastic
	03-502-04	Scalpel handle No. 4
	03-512-22	Scalpel blade No. 22 (2 pcs.)
	19-119-12	Dissecting scissors straight 12.5 cm
	19-131-00	Pipette filler disposable
	19-109-03	Dissecting needle blunt curved stainless

	Item No.	Description		Item No.	Description
	19-128-00	Set of 12 pieces consisting of:		19-130-00	Ruler 15 cm plastic
	03-502-04	Scalpel handle No. 4		19-109-13	Dissecting needle stainless steel straight
	03-512-22	Scalpel blade No. 22 (2 pcs)		04-688-11	Iris scissors 11.5 cm straight
	03-512-23	Scalpel blade No. 23 (2 pcs)		04-181-14	Operating scissors straight 14.5 cm
	19-131-00	Pipette filler disposable			
	05-976-12	Iris dressing forceps 12.5 cm straight			
	05-97-12	Iris dressing forceps 12.5 cm curved			
	19-114-00	Dissecting needle straight			
	19-115-00	Dissecting needle curved			

Microscopic instrument set in wooden case  
 Mikroskopier-Besteck in Holzetui  
 Estuche de microscopia en caja de madera  
 Trousse pour microscopie, en boîte en bois  
 Microscopico set di strumenti nel caso di legno

	Item No.	Description
	19-129-00	Set of 6 pieces consisting of:
	03-502-04	Scalpel handle No. 4
	03-512-22	Scalpel blade No. 22 (2 pcs.)
	05-901-14	Dressing forceps serrated 14.5 cm
	05-923-14	Dressing forceps toothed 14.5 cm
	19-114-00	Dissecting needle straight sharp plastic
	19-114-06	Dissecting needle straight arrow point plastic



Dermatology – Hollowware  
Dermatologie – Hohlware  
Dermatología – Hueco  
Dermatologie – Creuse  
Dermatologia – Hollowware



**Gavin**

20-300-00

for children  
für Kinder  
para niños  
pour enfants  
per bambini

20-301-00

for adults  
für Erwachsene  
para adultos  
pour adultes  
per adulti



**Miller**

20-302-00

Child size with silicone coating  
Kindergrößen size mit Silikonbeschichtung  
Tamaño infantil con revestimiento de silicona  
Taille de l'enfant avec revêtement en silicone  
Formato del bambino con rivestimento in silicone

20-303-00

Adult size with silicone coating  
Erwachsene Größe mit Silikonbeschichtung  
Tamaño adulto con revestimiento de silicona  
Taille adulte avec revêtement de silicone  
Dimensione adulta con rivestimento in silicone



**Martin-Ideal Nail Drill**

20-304-00	Set consisting:
	Nail drill
20-305-01	Fig. 1
20-305-02	Fig. 2
20-305-03	Fig. 3



20-305-01

Fig. 1

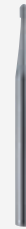

20-305-02

Fig. 2



20-305-03

Fig. 3



**Feldheim**

20-306-10 10 cm - 4"

Tourniquet for fingers and toes  
Finger- und Zehenkompressorium  
Tourniquete para los dedos de manos y piés  
Tourniquet pour doigts des mains et pieds  
Compressorio per dita di mano e piede

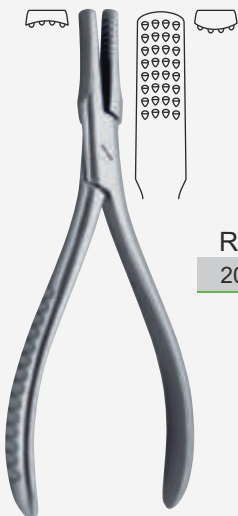

**Radolf**

20-307-13 13.5 cm - 5 1/4"

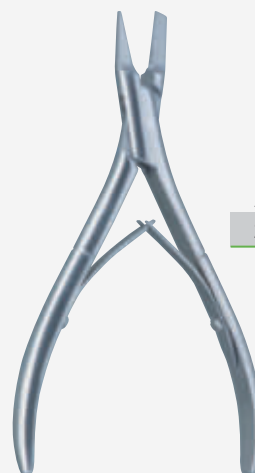

**Anvil**

20-308-12 12.5 cm - 5"

Finger ring saw  
 Fingerringsäge  
 Sierras para abrir anillos  
 Scies pour couper des bagues  
 Anello dito sega

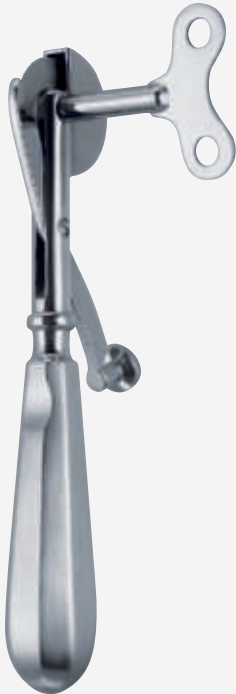

**Ferris**

20-309-17

17 cm - 6 ¾"

20-310-17

Blade only  
 Sägeblatt allein  
 Hoja sola  
 Lame seule  
 Lama sola



**Walton**

20-311-16

16 cm - 6 ¼"

20-312-16

Blade only  
 Sägeblatt allein  
 Hoja sola  
 Lame seule  
 Lama sola



**Stone**

20-313-17

17 cm - 6 ¾"

20-314-17

Blade only  
 Sägeblatt allein  
 Hoja sola  
 Lame seule  
 Lama sola

Hook lets  
 Håkchen  
 Ganchos  
 Crochets  
 Hook lascia



**Kilner**

20-315-15

15 cm - 6"



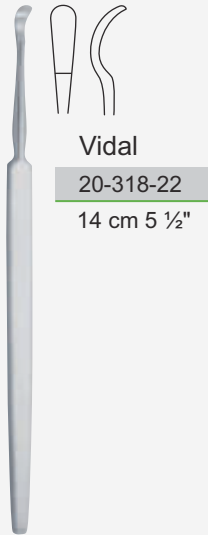

**Fox**

20-319-14

Fig. 1

3 mm Ø



20-320-14

Fig. 2

4 mm Ø



20-321-14

Fig. 3

5 mm Ø



20-322-14

Fig. 4

6 mm Ø

14 cm - 5 ½"



**Wolff**

20-323-14

Fig. 1



20-324-14

Fig. 2



20-325-14

Fig. 3



20-326-14

Fig. 4



20-327-14

Fig. 5



20-328-14

Fig. 6

14 cm - 5 ½"



○	○	○	○	○	○	○	○
<b>Keys</b>							
20-329-12	20-330-12	20-331-12	20-332-12	20-333-12	20-334-12	20-335-12	12 cm - 4 ¾"
Fig. 1	Fig. 2	Fig. 3	Fig. 4	Fig. 5	Fig. 6	Fig. 7	
2 mm Ø	3 mm Ø	4 mm Ø	5 mm Ø	6 mm Ø	7 mm Ø	8 mm Ø	

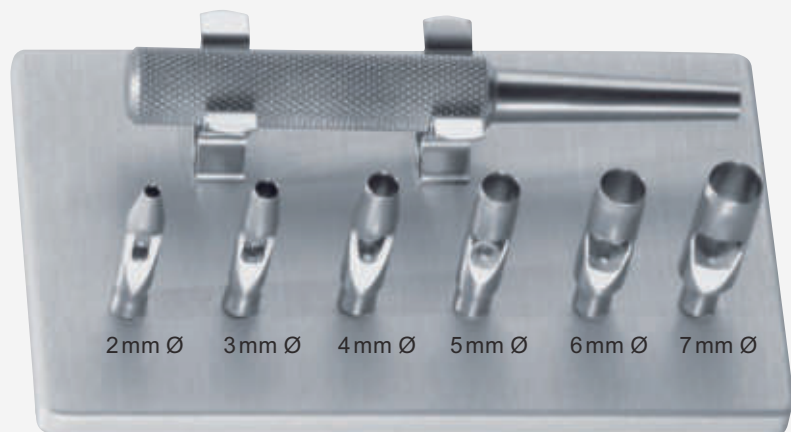

**Keys**

20-336-00	Set consisting:
20-343-12	Handle
	Tips 20-337-12 to 20-342-12
20-336-00	Holding plate

○	○	○	○	○	○	○
<b>Keys</b>						
20-337-12	20-338-12	20-339-12	20-340-12	20-341-12	20-342-12	12 cm - 4 ¾"
2 mm Ø	3 mm Ø	4 mm Ø	5 mm Ø	6 mm Ø	7 mm Ø	
Tips						
Aufsätze						
Puntas						
Pointes						
Testine						

**Keys**

20-343-12
12 cm - 4 ¾"
Handle, only
Griff, allein
Mango, solo
Manche, seul
Manico, solo

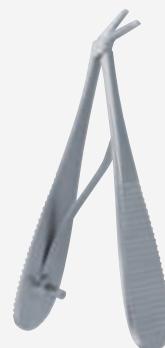

**Holth**

20-344-09
9 cm - 3 ½"
2mm
Punch
Hautstanze
Punzón
Poinçon
Punzone

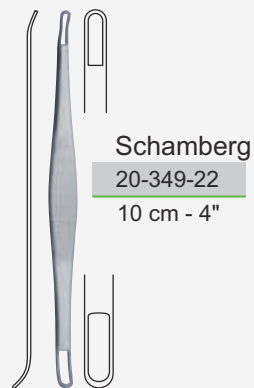
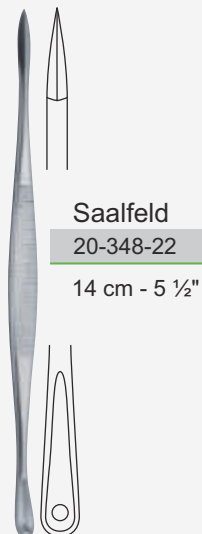
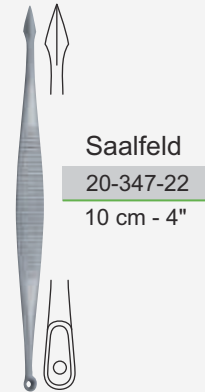
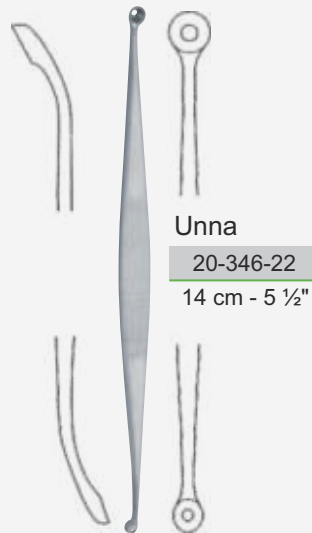
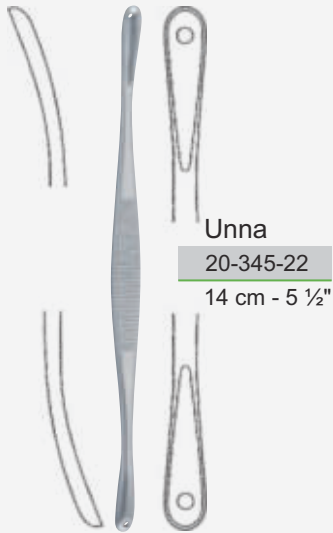

Forceps to open infusion bottles  
Infusionsflaschenönungszange  
Pinza para abrir botellas de infusión  
Pince pour ouvrir des bouteilles d'infusion  
Pinze per aprire le bottiglie di infusione



Hiveport  
20-351-22  
20 cm - 8"

Sterilizing forceps - waste forceps  
Sterilisierzangen - Abfallzangen  
Pinzasde estérilización - pinzasde basuras  
Pinces à stérilisation - pince à déchets  
Sterilizzazione pinza - pinza rifiuti



Cheatle  
20-352-22  
27 cm - 10 3/4"



Rogge  
20-353-22  
23 cm - 9"



Rogge  
20-354-22  
20 cm - 8"  
20-355-22  
30 cm - 12"

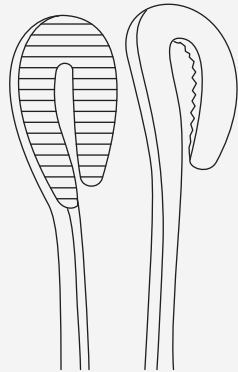

Universal

20-356-20

20-356-28

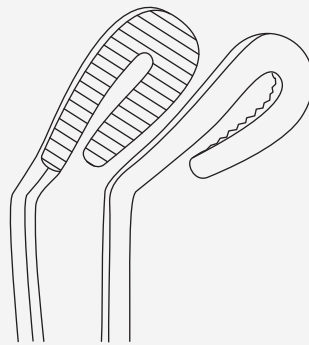

20-357-20 20 cm - 8"

20-357-28 28 cm - 11"



Bunt

20-358-14 12 cm - 4 ¾"



Mayo

20-359-12 12 cm - 4 ¾"

20-359-14 14 cm - 5 ½"

20-359-16 16 cm - 6 ¼"



Forceps Jar - Fig. 2

21-244-25 25 cm - 9 ¾"

21-244-32 32 cm - 12 ½"



Forceps Jar - Fig. 1

21-235-00 Ø 30 x 90 mm

21-236-00 Ø 50 x 100 mm

21-237-00 Ø 50 x 130 mm

21-238-00 Ø 50 x 175 mm

21-239-00 Ø 75 x 100 mm

21-240-00 Ø 75 x 130 mm

21-241-00 Ø 75 x 175 mm

21-242-00 Ø 100 x 175 mm

21-243-00 Ø 100 x 200 mm

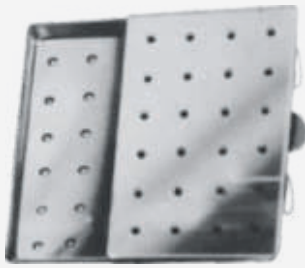

**Sauerbruch**

20-365-50 50.0 mm x 25.0 mm x 4.5 mm

20-365-65 65.0 mm x 42.0 mm x 8.0 mm

20-365-75 75.0 mm x 25.0 mm x 4.5 mm

18/8 stainless steel	perforated
18/8 rostfrei	gelocht
18/8 inoxidable	perforado
18/8 inoxydable	perforé
18/8 inossidabile	perforato



**Needle Sterilization Tub**

20-366-65 65 mm Ø x 17 mm

perforated insert, outer case not perforated, 18/8 stainless steel  
 gelochte Innendose, ungelochte Außendose, 18/8 rostfrei  
 inserto perforado caja no perforada, 18/8 inoxidable  
 insert perforé, boîtier non perforé, 18/8 inoxydable  
 scatola interna forata, scatola esterna non forata, inossidabile 18/8

20-366-62 62 mm Ø x 15 mm

perforated insert, 18/8 stainless steel  
 gelochte Innendose, 18/8 rostfrei  
 inserto perforado 18/8 inoxidable  
 insert perforé, 18/8 inoxydable  
 scatola interna forata, 18/8 inossidabil



**Sauerbruch**

20-367-15 150 mm x 95 mm x 13 mm

base and cover perforated, 18/8 stainless steel  
 Boden und Deckel perforiert, 18/8 Edelstahl  
 base y tapa perforada, acero inoxidable 18/8  
 base et couvercle perforés, acier inoxydable 18/8  
 base e coperchio forati, acciaio inossidabile 18/8



**Sauerbruch**

20-368-15

base not perforated  
 Basis nicht perforiert  
 base no perforada  
 base non perforée  
 base non perforata

20-369-15

base perforated  
 Boden perforiert  
 base perforada  
 base perforés  
 base forati

20-370-15 150 mm x 95 mm x 13 mm

Cover not perforated, bottom perforated  
 Deckel ungelocht, Boden gelocht  
 Tapa no perforado, caja perforada  
 Couvercle non perforé, boîtier perforé  
 Coperchio non perforato, fondo perforato

18/8 stainless steel  
 18/8 rostfrei  
 18/8 inoxidable  
 18/8 inoxydable  
 18/8 inossidabile





Lotion Bowl

20-371-16	0.75 l	165 mm Ø x 60 mm
20-371-17	1.00 l	175 mm Ø x 70 mm
20-371-22	2.00 l	220 mm Ø x 80 mm
20-371-24	3.00 l	240 mm Ø x 110 mm
20-371-27	4.50 l	275 mm Ø x 115 mm
20-371-29	6.00 l	290 mm Ø x 125 mm
20-371-31	6.00 l	310 mm Ø x 120 mm
20-371-34	8.50 l	345 mm Ø x 125 mm
20-371-38	11.00 l	380 mm Ø x 130 mm



Galipot

20-372-40	0.05 l	40 mm Ø x 19 mm
20-372-61	0.07 l	61 mm Ø x 30 mm
20-372-80	0.14 l	80 mm Ø x 40 mm
20-372-11	0.35 l	116 mm Ø x 50 mm
20-372-12	0.45 l	128 mm Ø x 55 mm
20-372-14	0.70 l	147 mm Ø x 65 mm

Bowls, tarnished, 18/8 stainless steel  
Schüsseln und Laborschalen, matt, 18/8 rostfrei  
Palanganas, 18/8 inoxidable  
Coupoles, depoli, 18/8 inoxydable  
Scodelle, inossidabile 18/8



Kidney Tray

20-373-15	Ø 150 mm
20-373-17	Ø 170 mm
20-373-20	Ø 200 mm
20-373-25	Ø 250 mm
20-373-27	Ø 300 mm

Round top edges



Kidney Tray

20-374-15	Ø 150 mm
20-374-17	Ø 170 mm
20-374-20	Ø 200 mm
20-374-25	Ø 250 mm
20-374-27	Ø 300 mm

Straight / flat edges



Kidney Tray With Lid

21-247-15	150 mm
21-247-18	180 mm
21-247-20	200 mm
21-247-25	250 mm
21-247-30	300 mm

Kidney bowls, tarnished, 18/8 stainless steel  
Nierenschalen, matt, 18/8 rostfrei  
Haricots, depoli, 18/8 inoxydable  
Rifioneras, 18/8 inoxidable  
Baccinella reniforme, 18/8 inossidabile



20-379-95 95 mm Ø x 60 mm

Sputum mugs, tarnished, 18/8 stainless steel  
 Sputumbecher, matt, 18/8 rostfrei  
 Coupoles, depoli, 18/8 inoxydable  
 Escupideras, mate, 18/8 inoxidable  
 Sputacchiera, 18/8 inossidabile



Medicine Cup

21-170-25 25 ml

21-170-50 50 ml

21-170-75 75 ml

Graduated



Cotton Jar

20-381-95 95 mm Ø x 60 mm

20-381-10 105 mm Ø x 60 mm

20-381-12 120 mm Ø x 120 mm

20-381-16 160 mm Ø x 140 mm

Dressing jars with cover, 18/8 stainless steel  
 Wattedosen mit Knopfde kel,c 18/8 rostfrei  
 Dispensadoresde algodón , 18/8 inoxidable  
 Boîtesà pansements avec couvercle, 18/8 inoxydable  
 Dispensori di cotone, 18/8 inossidabile



Dressing Jar With Lid

21-192-00 Ø 80 x 60 mm

21-193-00 Ø 80 x 80 mm

21-194-00 Ø 100 x 60 mm

21-195-00 Ø 100 x 80 mm

21-196-00 Ø 100 x 100 mm

21-197-00 Ø 120 x 80 mm

21-198-00 Ø 120 x 100 mm

21-199-00 Ø 120 x 120 mm

21-200-00 Ø 150 x 100 mm

21-201-00 Ø 150 x 150 mm

21-202-00 Ø 180 x 150 mm

21-203-00 Ø 180 x 180 mm

21-204-00 Ø 200 x 200 mm

21-205-00 Ø 240 x 240 mm





Urinal Jug  
21-206-00



Male Urinal  
21-207-00



Female Urinal  
21-208-00



Bed Pan  
21-209-00    Ø235 mm  
21-210-00    Ø320 mm



Bed Pan  
21-211-00    Ø235 mm  
21-212-00    Ø320 mm



Bed Pan  
21-213-00



Bed Pan  
21-214-00    350 x 290 x 90.5 mm  
American pattern



Bed Pan With Lid  
21-215-00    305 x 235 mm  
21-216-00    355 x 290 mm



Bed Pan With Lid And Handle  
21-217-00    305 x 235 mm  
21-218-00    355 x 290 mm



Jug

21-160-00	0.25 L
21-161-00	0.50 L
21-162-00	1.00 L
21-163-00	2.00 L

Graduated



Jug With Spot

21-164-00	0.25 L
21-165-00	0.50 L
21-166-00	1.00 L
21-167-00	2.00 L

Graduated



Bucket With Lid

21-168-12	12 L
21-168-15	15 L



Bucket

21-169-08	8 L
21-169-10	10 L
21-169-15	15 L



**Instruments Tray**

20-384-20	200 mm x 150 mm x 20 mm
20-384-24	240 mm x 160 mm x 30 mm
20-384-30	300 mm x 220 mm x 30 mm
20-384-35	350 mm x 250 mm x 40 mm
20-384-40	400 mm x 300 mm x 40 mm



**Instruments Box With Lid**

20-385-16	165 mm x 90 mm x 35 mm
20-385-20	200 mm x 100 mm x 50 mm
20-385-22	220 mm x 150 mm x 50 mm
20-385-26	260 mm x 50 mm x 50 mm
20-385-30	305 mm x 205 mm x 50 mm



**Instruments Box**

21-364-00	21-364-00	200 x 100 x 40 mm
21-365-00	21-365-00	200 x 100 x 50 mm
21-366-00	21-366-00	200 x 125 x 50 mm
21-367-00	21-367-00	230 x 125 x 60 mm
21-368-00	21-368-00	250 x 125 x 60 mm
21-369-00	21-369-00	250 x 150 x 60 mm
21-370-00	21-370-00	300 x 150 x 60 mm
21-371-00	21-371-00	505 x 200 x 125 mm

With handles

Without handles



**Instruments Tray With Straight Lid**

21-279-00	150 x 100 x 50 mm
21-280-00	200 x 100 x 50 mm
21-281-00	220 x 120 x 50 mm
21-282-00	240 x 140 x 50 mm
21-283-00	200 x 150 x 50 mm
21-284-00	250 x 200 x 50 mm
21-285-00	300 x 200 x 50 mm
21-286-00	300 x 250 x 50 mm
21-287-00	350 x 250 x 50 mm
21-288-00	400 x 300 x 50 mm
21-289-00	450 x 300 x 50 mm
21-290-00	450 x 350 x 50 mm

Sterilization Drums  
 Sterilisationstrommeln  
 tambores de esterilización  
 Tambours De Stérilisation  
 Tamburi di sterilizzazione



Sterilization Drum

21-220-00	Ø 80 x 80 mm
21-221-00	Ø 105 x 120 mm
21-222-00	Ø 140 x 140 mm
21-223-00	Ø 160 x 120 mm
21-224-00	Ø 160 x 150 mm
21-225-00	Ø 190 x 150 mm
21-226-00	Ø 190 x 190 mm
21-227-00	Ø 240 x 160 mm
21-228-00	Ø 240 x 240 mm
21-229-00	Ø 290 x 160 mm
21-230-00	Ø 290 x 240 mm
21-231-00	Ø 340 x 160 mm
21-232-00	Ø 340 x 340 mm
21-233-00	Ø 390 x 190 mm
21-234-00	Ø 80 x 290 mm

Sterilizing cases  
 Sterilisierbehälter  
 Cajas para esterilización  
 Boîtes de stérilisation  
 sterilizzazione casi



20-390-40	402 mm x 158 mm x 112 mm
20-391-40	402 mm x 158 mm x 52 mm
20-391-39	392 mm x 138 mm x 77 mm
20-392-39	392 mm x 138 mm x 32 mm
20-392-18	182 mm x 138 mm x 32 mm
20-392-30	302 mm x 158 mm x 112 mm
20-393-30	302 mm x 158 mm x 52 mm
20-393-33	332 mm x 118 mm x 67 mm
20-394-33	332 mm x 118 mm x 27 mm
20-394-16	162 mm x 118 mm x 27 mm



21-439-00  
Brush for hands and nails



21-440-00 210 x 95 mm



09-145-12  
12 cm - 4 ¾"

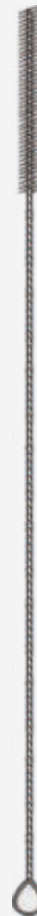

09-145-23  
23.5 cm - 9 ¼"



09-145-33  
33 cm - 13"

Oil Spray  
Öl-Spray  
Spray de aceite  
Pulvérisation d'huile  
Olio spray

**comed**  
operate better with us



21-441-33  
400 ml



21-442-00 5000 ml  
21-443-00 4 x 5000 ml



Sterilization  
Sterilisation  
Esterilización  
Stérilisation  
Sterilizzazione

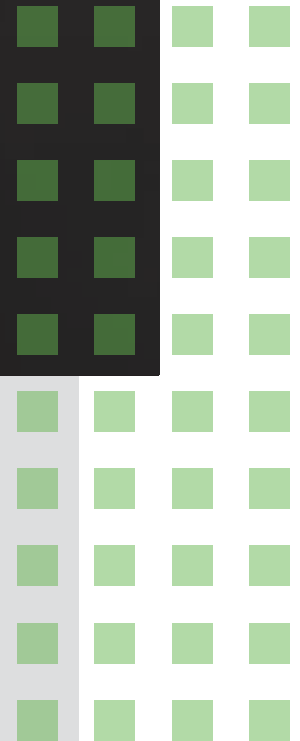

Packing		Requirements according to:						
Type	Description	Symbolic Delivery and Packaging System	DIN EN 285	DIN 58946-1				
				Gravity Procedure	Pre-Vacuum Procedure	Fractional Vacuum Procedure	Fractional Flow Procedure	Steam Injection Procedure
	Textiles in sterilization container with filter inside lid and bottom.		+	+	+	+	+	+
			+	0	0	+	+	+
	Textiles in sterilization container with filter inside lid, and not perforated bottom.		+	-	-	+	+	+
			+	-	-	+	+	0
	Textiles in sterilization container with filter inside bottom and not perforated lid.		+	0	+	+	+	+
			+	-	0	+	+	+
	Instruments in wire baskets inside sterilisation container with filter inside lid and bottom.		+	+2)	+	+	+	+
	Instruments in wire baskets in sterilization container with filter inside lid and not perforated bottom.		+	-	+2)	+2)	+2)	+3)
	Instruments in wire baskets inside sterilization container with filter inside bottom.		+	0	+	+	+	+



Packing		Requirements according to:						
Type	Description	Symbolic Delivery and Packaging System	DIN EN 285	DIN 58946-1				
				Gravity Procedure	Pre-Vacuum Procedure	Fractional Vacuum Procedure	Fractional Flow Procedure	Steam Injection Procedure
	Textiles in sterilization container with valve inside lid and bottom.		+	-	<b>0</b>	+	+	<b>0</b>
			+	-	-	+	+	<b>0</b>
	Textiles in sterilization container with valve inside lid and no valve in the bottom.		+	-	-	+	+	-
			+	-	-	+	+	-
	Instruments in wire baskets inside sterilization container with valve inside lid and bottom.		+	-	+2)	+2)	+2)	+2)
	Instruments in wire baskets inside sterilization container with valve inside lid, no valve in the bottom.		+	-	+2)	+2)	+2)	+2)

Legend: + applicable, – not applicable, 0 applicable under certain conditions

1). To avoid service, operation and/or loading errors, see Table 1 for some recommendations regarding the correct or incorrect combination of sterilization containers with standard steam sterilisation procedures.

2). Only sterilisation containers from which the condensate evaporation or flow off is guaranteed are suitable.

3). The gravity procedure without a drying device does not provide sufficient re-drying.



Standard Model



Safety Model

GB

Choose between our standard and our safety model. The safety lid protects against contamination while transport and stocking. Filter- and safety lid can only separate by opening container.

DE

Wählen Sie zwischen unserem Standard- und unserem Sicherheitsmodell. Der Sicherheitsdeckel schützt vor Kontamination bei Transport und Lagerung. Filter- und Sicherheitsdeckel lassen sich nur durch Öffnen des Behälters trennen.

ES

Elija entre nuestro estándar y nuestro modelo de seguridad. La tapa de seguridad protege contra la contaminación durante el transporte y almacenamiento. El filtro y la tapa de seguridad solo pueden separarse abriendo el recipiente.

FR

Choisissez entre notre modèle standard et notre modèle de sécurité. Le couvercle de sécurité protège contre la contamination pendant le transport et le stockage. Le filtre et le couvercle de sécurité ne peuvent se séparer qu'en ouvrant le récipient.

IT

Scegli tra il nostro modello standard e il nostro modello di sicurezza. Il coperchio di sicurezza protegge dalla contaminazione durante il trasporto e lo stoccaggio. Il filtro e il coperchio di sicurezza possono essere separati solo aprendo il contenitore.



Lid Perforated, Bottom Non Perforated



Lid Perforated, Bottom Perforated



GB

The locking flaps are movable 180° on a pivot and can be secured in any position.

DE

Die Verschlussklappen sind um 180° auf einem Drehpunkt beweglich und können in jeder Position arretiert werden.

ES

Las aletas de bloqueo se pueden mover 180° sobre un pivote y se pueden asegurar en cualquier posición.

FR

Les volets de verrouillage sont mobiles à 180° sur un pivot et peuvent être bloqués dans n'importe quelle position.

IT

Le alette di chiusura sono mobili di 180° su un perno e possono essere fissate in qualsiasi posizione.



GB

The filter retainer is locked by pressing down in center of the filter. Opening the filter retainer by pressing.

DE

Der Filterhalter wird durch Herunterdrücken in der Mitte des Filters verriegelt. Öffnen des Filterhalters durch Drücken.

ES

El retenedor del filtro se bloquea presionando hacia abajo en el centro del filtro. Apertura del portafiltros presionando.

FR

Le dispositif de retenue du filtre est verrouillé en appuyant au centre du filtre. Ouverture du porte-filtre par pression.

IT

Il fermo del filtro si blocca premendo al centro del filtro. Apertura del portafiltro premendo.

1/1 Size Container - Standard Model



Non perforated Bottom



Perforated Bottom

21-444-01
21-444-02
21-444-03
21-444-04
21-444-05
21-444-06

Weight: 2634 gm

21-445-01
21-445-02
21-445-03
21-445-04
21-445-05
21-445-06

Weight: 3156 gm



Outside: 580 x 280 x 100 mm  
 Inside: 550 x 265 x 84 mm

21-446-01
21-446-02
21-446-03
21-446-04
21-446-05
21-446-06

Weight: 3125.5 gm

21-447-01
21-447-02
21-447-03
21-447-04
21-447-05
21-447-06

Weight: 3244 gm



Outside: 580 x 280 x 135 mm  
 Inside: 550 x 265 x 115 mm

21-444-01
21-444-02
21-444-03
21-444-04
21-444-05
21-444-06

Weight: 2634 gm

21-445-01
21-445-02
21-445-03
21-445-04
21-445-05
21-445-06

Weight: 3156 gm



Outside: 580 x 280 x 150 mm  
 Inside: 550 x 265 x 130 mm

21-448-01
21-448-02
21-448-03
21-448-04
21-448-05
21-448-06

Weight: 3219 gm

21-449-01
21-449-02
21-449-03
21-449-04
21-449-05
21-449-06

Weight: 3382 gm



Outside: 580 x 280 x 200 mm  
 Inside: 550 x 265 x 180 mm

21-450-01
21-450-02
21-450-03
21-450-04
21-450-05
21-450-06

Weight: 3429.5 gm

21-451-01
21-451-02
21-451-03
21-451-04
21-451-05
21-451-06

Weight: 3738.5 gm



Outside: 580 x 280 x 260 mm  
 Inside: 550 x 265 x 240 mm

1/1 Size Container - Safety Model



Non perforated  
Bottom



Perforated  
Bottom

21-454-01
21-454-02
21-454-03
21-454-04
21-454-05
21-454-06

Weight: 3486 gm

21-455-01
21-455-02
21-455-03
21-455-04
21-455-05
21-455-06

Weight: 4007.5 gm



Outside: 580 x 280 x 100 mm  
Inside: 550 x 265 x 84 mm

21-456-01
21-456-02
21-456-03
21-456-04
21-456-05
21-456-06

Weight: 3981.5 gm

21-457-01
21-457-02
21-457-03
21-457-04
21-457-05
21-457-06

Weight: 4095.5 gm



Outside: 580 x 280 x 135 mm  
Inside: 550 x 265 x 115 mm

21-458-01
21-458-02
21-458-03
21-458-04
21-458-05
21-458-06

Weight: 4070.5 gm

21-459-01
21-459-02
21-459-03
21-459-04
21-459-05
21-459-06

Weight: 4233 gm



Outside: 580 x 280 x 150 mm  
Inside: 550 x 265 x 130 mm

21-460-01
21-460-02
21-460-03
21-460-04
21-460-05
21-460-06

Weight: 4280 gm

21-461-01
21-461-02
21-461-03
21-461-04
21-461-05
21-461-06

Weight: 4589 gm



Outside: 580 x 280 x 200 mm  
Inside: 550 x 265 x 180 mm

21-462-01
21-462-02
21-462-03
21-462-04
21-462-05
21-462-06

Weight: 4770.5 gm

21-463-01
21-463-02
21-463-03
21-463-04
21-463-05
21-463-06

Weight: 5140 gm



Outside: 580 x 280 x 260 mm  
Inside: 550 x 265 x 240 mm



Non perforated  
Bottom

	Outside	Inside	Weight
21-464-01	580 x 280 x 100 mm	550 x 262 x 84 mm	1923 gm
21-464-02	580 x 280 x 135 mm	550 x 262 x 117 mm	2019 gm
21-464-03	580 x 280 x 150 mm	550 x 262 x 132 mm	2108 gm
21-464-04	580 x 280 x 200 mm	550 x 262 x 182 mm	2317 gm
21-464-05	580 x 280 x 260 mm	550 x 262 x 244 mm	2808 gm



Perforated  
Bottom

	Outside	Inside	Weight
21-465-01	580 x 280 x 100 mm	550 x 262 x 84 mm	2044 gm
21-465-02	580 x 280 x 135 mm	550 x 262 x 117 mm	2132 gm
21-465-03	580 x 280 x 150 mm	550 x 262 x 132 mm	2270 gm
21-465-04	580 x 280 x 200 mm	550 x 262 x 182 mm	2627 gm
21-465-05	580 x 280 x 260 mm	550 x 262 x 244 mm	2851 gm

1/1 Size Container - Bottoms and Lids



Perforated lid



21-466-01
21-466-02
21-466-03
21-466-04
21-466-05
21-466-06

Weight: 1111 gm  
 Size: 580 x 280 mm

Safety Lid

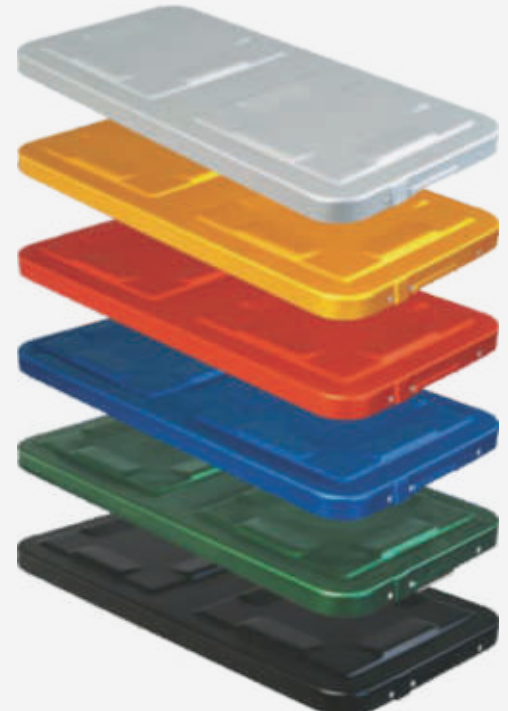

21-467-01
21-467-02
21-467-03
21-467-04
21-467-05
21-467-06

Weight: 851.5 gm  
 Size: 580 x 280 mm

1/1 Size Container - Wire Baskets

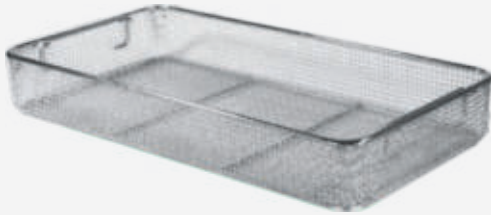

Wire Basket

21-548-01	485 x 255 x 30 mm
21-548-02	485 x 255 x 50 mm
21-548-03	485 x 255 x 70 mm
21-548-04	485 x 255 x 100 mm

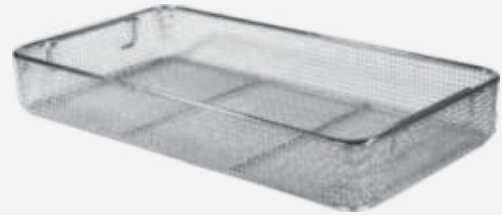

Wire Basket

21-545-01	540 x 255 x 30 mm
21-545-02	540 x 255 x 50 mm
21-545-03	540 x 255 x 70 mm
21-545-04	540 x 255 x 100 mm



Wire Base

21-611-03	545 x 255 x 30 mm
-----------	-------------------



Drape Retainer

21-612-05	545 x 255 mm
-----------	--------------



Drape

21-610-07	130 x 60 cm
21-610-08	140 x 100 cm
21-610-09	185 x 45 cm
21-610-10	185 x 60 cm

1/1 Size Container - Safety Model



Non perforated  
Bottom

Grey	21-468-01
Yellow	21-468-02
Red	21-468-03
Blue	21-468-04
Green	21-468-05
Black	21-468-06

Weight: 2268.5 gm



Perforated  
Bottom

Grey	21-469-01
Yellow	21-469-02
Red	21-469-03
Blue	21-469-04
Green	21-469-05
Black	21-469-06

Weight: 2503 gm



Outside: 465 x 280 x 100 mm  
 Inside: 425 x 265 x 84 mm

Grey	21-470-01
Yellow	21-470-02
Red	21-470-03
Blue	21-470-04
Green	21-470-05
Black	21-470-06

Weight: 2549.5 gm

Grey	21-471-01
Yellow	21-471-02
Red	21-471-03
Blue	21-471-04
Green	21-471-05
Black	21-471-06

Weight: 2715 gm



Outside: 465 x 280 x 135 mm  
 Inside: 425 x 265 x 115 mm

Grey	21-472-01
Yellow	21-472-02
Red	21-472-03
Blue	21-472-04
Green	21-472-05
Black	21-472-06

Weight: 2620.5 gm

Grey	21-473-01
Yellow	21-473-02
Red	21-473-03
Blue	21-473-04
Green	21-473-05
Black	21-473-06

Weight: 2718 gm



Outside: 465 x 280 x 150 mm  
 Inside: 425 x 260 x 130 mm



1/1 Size Container - Safety Model



Non perforated  
Bottom

Grey	21-474-01
Yellow	21-474-02
Red	21-474-03
Blue	21-474-04
Green	21-474-05
Black	21-474-06

Weight: 2980 gm



Perforated  
Bottom

Grey	21-475-01
Yellow	21-475-02
Red	21-475-03
Blue	21-475-04
Green	21-475-05
Black	21-475-06

Weight: 3213.5 gm



Outside: 465 x 280 x 100 mm  
Inside: 425 x 265 x 84 mm

Grey	21-476-01
Yellow	21-476-02
Red	21-476-03
Blue	21-476-04
Green	21-476-05
Black	21-476-06

Weight: 3260 gm

Grey	21-477-01
Yellow	21-477-02
Red	21-477-03
Blue	21-477-04
Green	21-477-05
Black	21-477-06

Weight: 2425 gm



Outside: 465 x 280 x 135 mm  
Inside: 425 x 265 x 115 mm

Grey	21-478-01
Yellow	21-478-02
Red	21-478-03
Blue	21-478-04
Green	21-478-05
Black	21-478-06

Weight: 2975 gm

Grey	21-479-01
Yellow	21-479-02
Red	21-479-03
Blue	21-479-04
Green	21-479-05
Black	21-479-06

Weight: 3561 gm



Outside: 465 x 280 x 150 mm  
Inside: 425 x 260 x 130 mm



Non perforated  
Bottom

	Outside	Inside	Weight
21-480-01	465 x 280 x 100 mm	465 x 262 x 84 mm	1396 gm
21-480-02	465 x 280 x 135 mm	465 x 262 x 117 mm	1676 gm
21-480-03	465 x 280 x 150 mm	465 x 262 x 132 mm	1792 gm

1/1 Size Container - Bottoms and Lids



Perforated  
Bottom

	Outside	Inside	Weight
21-481-01	465 x 280 x 100 mm	425 x 262 x 84 mm	2044 gm
21-481-02	465 x 280 x 135 mm	425 x 262 x 117 mm	2132 gm
21-481-03	465 x 280 x 150 mm	425 x 262 x 132 mm	2270 gm



Perforated lid



21-482-01
21-482-02
21-482-03
21-482-04
21-482-05
21-482-06

Weight: 873 gm  
 Size: 465 x 280 mm

Safety Lid



21-483-01
21-483-02
21-483-03
21-483-04
21-483-05
21-483-06

Weight: 710 gm  
 Size: 465 x 280 mm

3/4 Size Container - Wire Baskets



Wire Basket

21-551-01	405 x 255 x 30 mm
21-551-02	405 x 255 x 50 mm
21-551-03	405 x 255 x 70 mm
21-551-04	405 x 255 x 100 mm



Wire Base

21-611-02	405 x 255 x 30 mm
-----------	-------------------



Drape Retainer

21-612-04	405 x 255 mm
-----------	--------------



Drape

21-610-08	140 x 100 cm
-----------	--------------

1/2 Size Container - Standard Model



Non perforated  
Bottom



Perforated  
Bottom

21-484-01
21-484-02
21-484-03
21-484-04
21-484-05
21-484-06

Weight: 1744.5 gm

21-485-01
21-485-02
21-485-03
21-485-04
21-485-05
21-485-06

Weight: 1890.5 gm



Outside: 285 x 280 x 100 mm  
 Inside: 262 x 260 x 84 mm

21-486-01
21-486-02
21-486-03
21-486-04
21-486-05
21-486-06

Weight: 1947 gm

21-487-01
21-487-02
21-487-03
21-487-04
21-487-05
21-487-06

Weight: 2125 gm



Outside: 285 x 280 x 135 mm  
 Inside: 262 x 260 x 115 mm

21-488-01
21-488-02
21-488-03
21-488-04
21-488-05
21-488-06

Weight: 1981 gm

21-489-01
21-489-02
21-489-03
21-489-04
21-489-05
21-489-06

Weight: 2462.5 gm



Outside: 285 x 280 x 150 mm  
 Inside: 262 x 260 x 132 mm

21-490-01
21-490-02
21-490-03
21-490-04
21-490-05
21-490-06

Weight: 2101 gm

21-491-01
21-491-02
21-491-03
21-491-04
21-491-05
21-491-06

Weight: 2513.5 gm



Outside: 285 x 280 x 200 mm  
 Inside: 262 x 260 x 180 mm

21-492-01
21-492-02
21-492-03
21-492-04
21-492-05
21-492-06

Weight: 2483.5 gm

21-493-01
21-493-02
21-493-03
21-493-04
21-493-05
21-493-06

Weight: 2657.5 gm



Outside: 285 x 280 x 260 mm  
 Inside: 262 x 260 x 238 mm

1/2 Size Container - Safety Model



Non perforated Bottom



Perforated Bottom

21-494-01
21-494-02
21-494-03
21-494-04
21-494-05
21-494-06

Weight: 2162.5 gm

21-495-01
21-495-02
21-495-03
21-495-04
21-495-05
21-495-06

Weight: 2309.5 gm



Outside: 285 x 280 x 100 mm  
Inside: 262 x 260 x 84 mm

21-496-01
21-496-02
21-496-03
21-496-04
21-496-05
21-496-06

Weight: 2351 gm

21-497-01
21-497-02
21-497-03
21-497-04
21-497-05
21-497-06

Weight: 2466 gm



Outside: 285 x 280 x 135 mm  
Inside: 262 x 260 x 116 mm

21-498-01
21-498-02
21-498-03
21-498-04
21-498-05
21-498-06

Weight: 2394 gm

21-499-01
21-499-02
21-499-03
21-499-04
21-499-05
21-499-06

Weight: 2583 gm



Outside: 285 x 280 x 150 mm  
Inside: 262 x 260 x 132 mm

21-500-01
21-500-02
21-500-03
21-500-04
21-500-05
21-500-06

Weight: 2560 gm

21-501-01
21-501-02
21-501-03
21-501-04
21-501-05
21-501-06

Weight: 2785.5 gm



Outside: 285 x 280 x 200 mm  
Inside: 262 x 260 x 182 mm

21-502-01
21-502-02
21-502-03
21-502-04
21-502-05
21-502-06

Weight: 2930 gm

21-503-01
21-503-02
21-503-03
21-503-04
21-503-05
21-503-06

Weight: 3069.5 gm



Outside: 285 x 280 x 260 mm  
Inside: 262 x 260 x 238 mm



Non perforated  
Bottom

	Outside	Inside	Weight
21-504-01	285 x 280 x 100 mm	262 x 262 x 82 mm	1096 gm
21-504-02	285 x 280 x 135 mm	262 x 262 x 120 mm	1284 gm
21-504-03	285 x 280 x 150 mm	262 x 262 x 135 mm	1327 gm
21-504-04	285 x 280 x 200 mm	262 x 262 x 185 mm	1447 gm
21-504-05	285 x 280 x 260 mm	262 x 262 x 240 mm	1817 gm

1/2 Size Container - Bottoms and Lids



Perforated  
Bottom

	Outside	Inside	Weight
21-505-01	285 x 280 x 100 mm	262 x 262 x 82 mm	1242 gm
21-505-02	285 x 280 x 135 mm	262 x 262 x 120 mm	1398 gm
21-505-03	285 x 280 x 150 mm	262 x 262 x 135 mm	1471 gm
21-505-04	285 x 280 x 200 mm	262 x 262 x 185 mm	1672 gm
21-505-05	285 x 280 x 260 mm	262 x 262 x 240 mm	2000 gm



Perforated lid



21-506-01
21-506-02
21-506-03
21-506-04
21-506-05
21-506-06

Weight: 254 gm  
 Size: 285 x 280 mm

Safety Lid

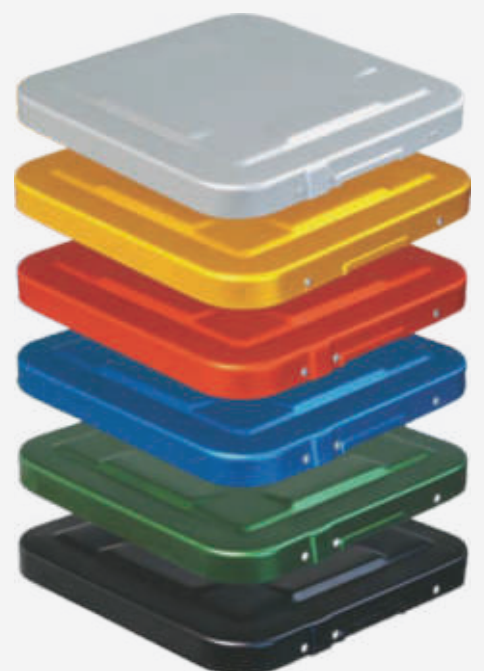

21-507-01
21-507-02
21-507-03
21-507-04
21-507-05
21-507-06

Weight: 458 gm  
 Size: 285 x 280 mm

1/2 Size Container - Wire Baskets

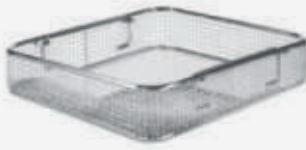

Wire Basket

21-554-01	255 x 245 x 30 mm
21-554-02	255 x 245 x 50 mm
21-554-03	255 x 245 x 70 mm
21-554-04	255 x 245 x 100 mm



Wire Base

21-611-01	255 x 245 x 30 mm
-----------	-------------------



Drape Retainer

21-612-03	255 x 245 mm
-----------	--------------



Drape

21-610-04	90 x 60 cm
21-610-05	90 x 80 cm
21-610-06	130 x 45 cm
21-610-07	130 x 60 cm

Flat Container - Containers and Bottoms



Non perforated  
Bottom



Perforated  
Bottom

21-508-01
21-508-02
21-508-03
21-508-04
21-508-05
21-508-06

Weight: 1285 gm



Outside: 285 x 280 x 55 mm  
 Inside: 270 x 270 x 33 mm

21-509-01
21-509-02
21-509-03
21-509-04
21-509-05
21-509-06

Weight: 1377 gm

21-510-01
21-510-02
21-510-03
21-510-04
21-510-05
21-510-06

Weight: 1529 gm



Outside: 600 x 400 x 180 mm  
 Inside: 550 x 350 x 160 mm



Non perforated  
Bottom

	Outside	Inside	Weight
21-511-01	285 x 280 x 55 mm	270 x 270 x 33 mm	611 gm
21-511-02	285 x 280 x 85 mm	270 x 270 x 64 mm	703 gm



Perforated  
Bottom

	Outside	Inside	Weight
21-512-01	285 x 280 x 85 mm	270 x 270 x 64 mm	857 gm





Flat Container - Lids and accessories



Grey	21-513-01
Yellow	21-513-02
Red	21-513-03
Blue	21-513-04
Green	21-513-05
Black	21-513-06

Weight: 674 gm



Wire Basket

21-554-01	255 x 245 x 30 mm
21-554-02	255 x 245 x 50 mm



Drape Retainer

21-612-03	255 x 245 mm
-----------	--------------



Wire Base

21-611-01	255 x 245 x 30 mm
-----------	-------------------

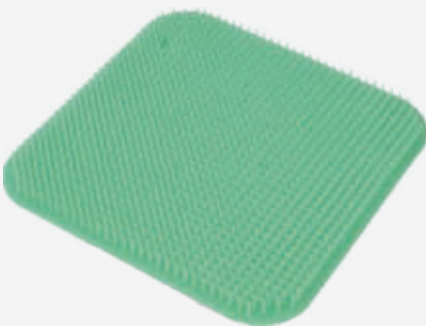

Silicone Mat

21-628-02	245 x 245 mm
-----------	--------------



Drape

21-610-04	90 x 60 cm
21-610-05	90 x 80 cm

Mini Container

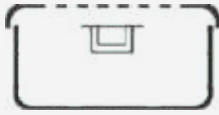

Non perforated  
Bottom



Perforated  
Bottom

Grey	21-514-01
Yellow	21-514-02
Red	21-514-03
Blue	21-514-04
Green	21-514-05
Black	21-514-06

Weight: 510.5 gm

Grey	21-515-01
Yellow	21-515-02
Red	21-515-03
Blue	21-515-04
Green	21-515-05
Black	21-515-06

Weight: 589 gm



Outside: 300 x 140 x 40 mm  
 Inside: 280 x 130 x 27 mm

Grey	21-516-01
Yellow	21-516-02
Red	21-516-03
Blue	21-516-04
Green	21-516-05
Black	21-516-06

Weight: 567 gm

Grey	21-517-01
Yellow	21-517-02
Red	21-517-03
Blue	21-517-04
Green	21-517-05
Black	21-517-06

Weight: 630 gm



Outside: 300 x 140 x 70 mm  
 Inside: 280 x 130 x 55 mm

Grey	21-518-01
Yellow	21-518-02
Red	21-518-03
Blue	21-518-04
Green	21-518-05
Black	21-518-06

Weight: 625.5 gm

Grey	21-519-01
Yellow	21-519-02
Red	21-519-03
Blue	21-519-04
Green	21-519-05
Black	21-519-06

Weight: 625 gm



Outside: 300 x 140 x 100 mm  
 Inside: 280 x 130 x 84 mm



Non perforated  
Bottom

	Outside	Inside	Weight
21-520-01	300 x 140 x 40 mm	280 x 130 x 27 mm	190 gm
21-520-02	300 x 140 x 70 mm	280 x 130 x 55 mm	241 gm
21-520-03	300 x 140 x 100 mm	280 x 130 x 84 mm	305 gm



Perforated  
Bottom

	Outside	Inside	Weight
21-521-01	300 x 140 x 40 mm	280 x 130 x 27 mm	258 gm
21-521-02	300 x 140 x 70 mm	280 x 130 x 55 mm	304 gm
21-521-03	300 x 140 x 100 mm	280 x 130 x 84 mm	326 gm

## Mini Container - Bottoms and Lids



Perforated lid

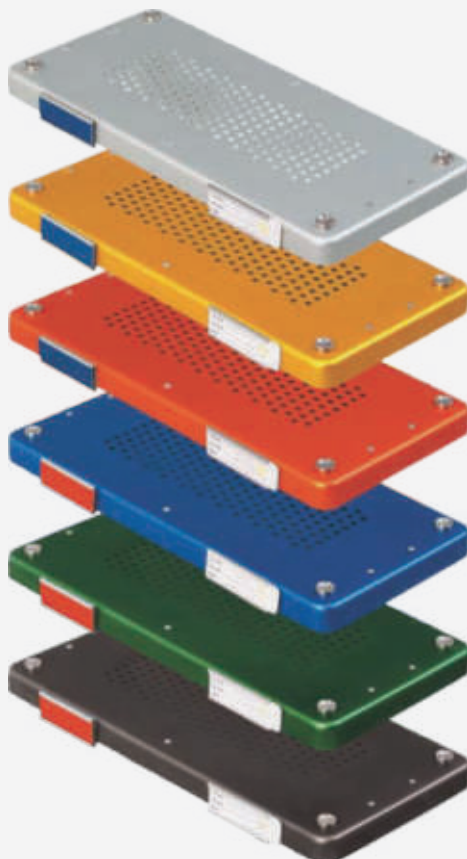

Grey	21-522-01
Yellow	21-522-02
Orange	21-522-03
Blue	21-522-04
Green	21-522-05
Black	21-522-06

Weight: 325.5 gm

Mini Container - Accessories



Drape Retainer  
21-612-01 280 x 125 mm



Silicone Mat  
21-628-01 270 x 125 mm



Drape  
21-610-01 60 x 40 cm

## Dental Containers



Perforated  
Bottom

21-523-01

Weight: 783 gm



Outside: 310 x 190 x 40 mm  
Inside: 280 x 182 x 35 mm



Perforated  
Bottom

21-524-01

Weight: 862 gm



Outside: 310 x 190 x 65 mm  
Inside: 280 x 182 x 55 mm



Perforated  
Bottom

21-525-01

Weight: 1022 gm



Outside: 310 x 190 x 130 mm  
Inside: 280 x 182 x 124 mm

Dental Container - Bottom, Lid and Accessories



Perforated Bottom

	Outside	Inside	Weight
21-526-01	310 x 190 x 40 mm	280 x 182 x 35 mm	341 gm
21-526-02	310 x 190 x 65 mm	280 x 182 x 55 mm	415 gm
21-526-03	310 x 190 x 130 mm	280 x 182 x 124 mm	570 gm



Perforated lid



21-527-01

Weight: 417 gm  
 Size: 310 x 190 mm



Drape Retainer

21-612-02 310 x 190 mm



Drape

21-610-01	60 x 40 cm
21-610-02	65 x 65 cm
21-610-03	85 x 85 cm

## Implant Containers



Lid perforated  
Bottom perforated (no filter)

Grey	21-528-01
Yellow	21-528-02
Red	21-528-03
Blue	21-528-04
Green	21-528-05
Black	21-528-06

Weight: 654 gm



Outside: 500 x 155 x 75 mm  
Inside: 495 x 155 x 75 mm



Lid perforated  
Bottom perforated (no filter)

Grey	21-529-01
Yellow	21-529-02
Red	21-529-03
Blue	21-529-04
Green	21-529-05
Black	21-529-06

Weight: 368 gm



Outside: 500 x 155 x 75 mm  
Inside: 495 x 155 x 75 mm

## Optik Containers



Lid perforated  
Bottom perforated (no filter)

21-530-01

Weight: 302 gm

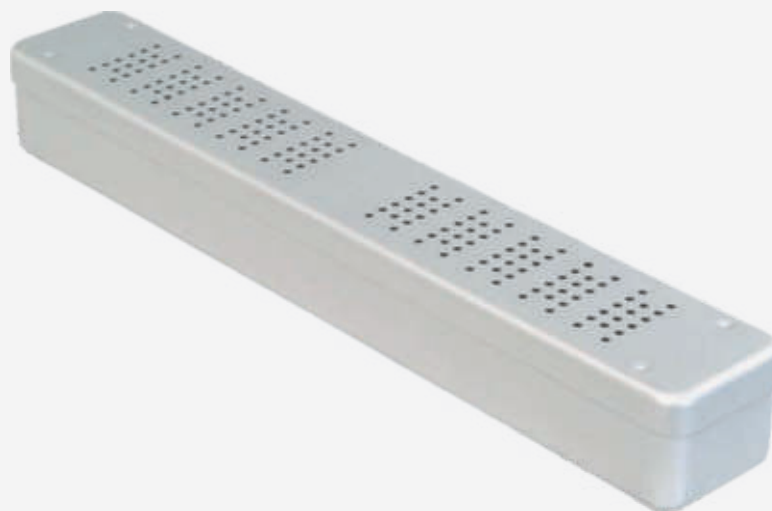

Outside: 450 x 70 x 70 mm  
Inside: 450 x 70 x 30 mm



Lid perforated  
Bottom perforated (no filter)

21-531-01

Weight: 152 gm



Outside: 250 x 60 x 50 mm  
Inside: 250 x 55 x 50 mm



## Removal Containers

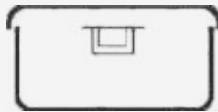

Non perforated  
Lid and Bottom

Grey	21-532-01
Yellow	21-532-02
Red	21-532-03
Blue	21-532-04
Green	21-532-05
Black	21-532-06

Weight: 1677 gm



Outside: 285 x 280 x 100 mm  
Inside: 262 x 260 x 82 mm



Non perforated  
Lid and Bottom

Grey	21-533-01
Yellow	21-533-02
Red	21-533-03
Blue	21-533-04
Green	21-533-05
Black	21-533-06

Weight: 1929 gm



Outside: 285 x 280 x 150 mm  
Inside: 262 x 260 x 132 mm

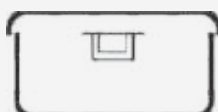

Non perforated  
Lid and Bottom

Grey	21-534-01
Yellow	21-534-02
Red	21-534-03
Blue	21-534-04
Green	21-534-05
Black	21-534-06

Weight: 2883 gm



Outside: 580 x 280 x 150 mm  
Inside: 548 x 258 x 130 mm

Removal Container - Bottoms and Lids



Non perforated  
Bottom

	Outside	Weight
21-535-01	580 x 280 x 150 mm	2108 gm



Non perforated  
Bottom

	Outside	Weight
21-536-01	285 x 280 x 150 mm	1096 gm
21-636-02	285 x 280 x 150 mm	1327 gm



Non-Perforated lid



21-537-01
21-537-02
21-537-03
21-537-04
21-537-05
21-537-06

Weight: 458 gm  
 Size: 285 x 280 mm

Non-Perforated lid

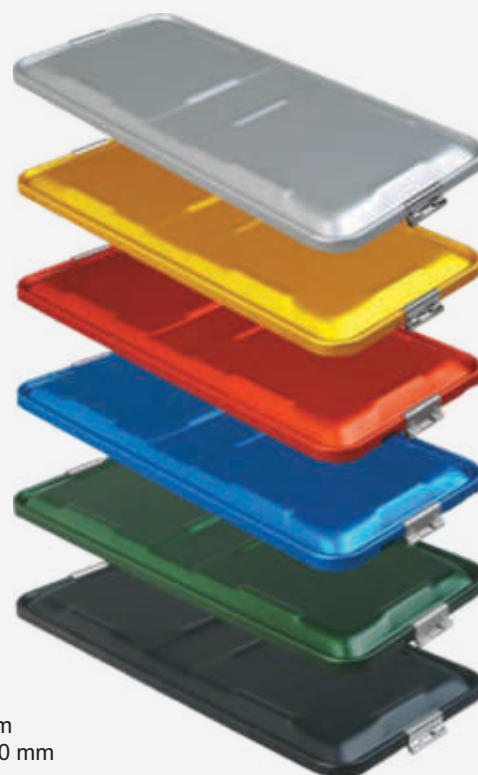

21-538-01
21-538-02
21-538-03
21-538-04
21-538-05
21-538-06

Weight: 875 gm  
 Size: 580 x 280 mm

## Brush Container - Stainless Steel and Aluminium



21-539-10 For 10 brushes

21-539-20 For 20 brushes

Stainless steel

■	21-540-01
■	21-540-02
■	21-540-03
■	21-540-04
■	21-540-05

Aluminium  
For 20 brushes  
Size: 240 x 275 x 70 mm



#### Single Tray Containers

21-541-01	200 x 140 x 50 mm
21-541-02	280 x 195 x 50 mm
21-541-03	265 x 255 x 50 mm
21-541-04	380 x 260 x 50 mm

For micro instruments



#### Double Tray Containers

21-542-01	280 x 195 x 50 mm
21-542-02	265 x 255 x 50 mm
21-542-03	380 x 260 x 50 mm

With 2 take-out perforated trays

## Baskets



21-543-01	540 x 255 x 30 mm
21-543-02	540 x 255 x 50 mm
21-543-03	540 x 255 x 70 mm
21-543-04	540 x 255 x 100 mm

Wire basket with lid

21-544-00

Lid only



21-545-01	540 x 255 x 30 mm
21-545-02	540 x 255 x 50 mm
21-545-03	540 x 255 x 70 mm
21-545-04	540 x 255 x 100 mm

Wire basket



21-546-01	485 x 255 x 30 mm
21-546-02	485 x 255 x 50 mm
21-546-03	485 x 255 x 70 mm
21-546-04	485 x 255 x 100 mm

Wire basket with lid

21-547-00

Lid only



21-548-01	485 x 255 x 30 mm
21-548-02	485 x 255 x 50 mm
21-548-03	485 x 255 x 70 mm
21-548-04	485 x 255 x 100 mm

Wire basket

Baskets



21-549-01	405 x 255 x 30 mm
21-549-02	405 x 255 x 50 mm
21-549-03	405 x 255 x 70 mm
21-549-04	405 x 255 x 100 mm

Wire basket with lid

21-550-00

Lid only



21-551-01	405 x 255 x 30 mm
21-551-02	405 x 255 x 50 mm
21-551-03	405 x 255 x 70 mm
21-551-04	405 x 255 x 100 mm

Wire basket



21-552-01	255 x 245 x 30 mm
21-552-02	255 x 245 x 50 mm
21-552-03	255 x 245 x 70 mm
21-552-04	255 x 245 x 100 mm

Wire basket with lid

21-553-00

Lid only



21-554-01	255 x 245 x 30 mm
21-554-02	255 x 245 x 50 mm
21-554-03	255 x 245 x 70 mm
21-554-04	255 x 245 x 100 mm

Wire basket

**Baskets**

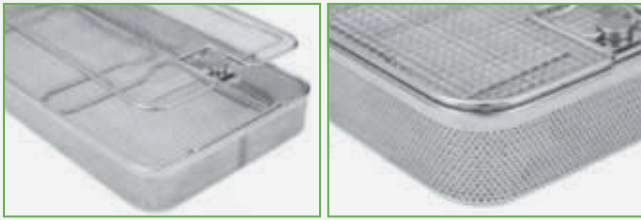

21-555-01 540x255x50 mm

21-555-02 540x255x70 mm

21-555-03 540x255x100 mm

Wire basket with lid

21-556-00

Lid only

21-557-01 485x255x50 mm

21-557-02 485x255x70 mm

21-557-03 485x255x100 mm

Wire basket with lid

21-558-00

Lid only



21-561-01 405x255x50 mm

21-561-02 405x255x70 mm

21-561-03 405x255x100 mm

Wire basket with lid

21-562-00

Lid only



21-564-01 255x245x50 mm

21-564-02 255x245x70 mm

21-564-03 255x245x100 mm

Wire basket with lid

21-565-00

Lid only

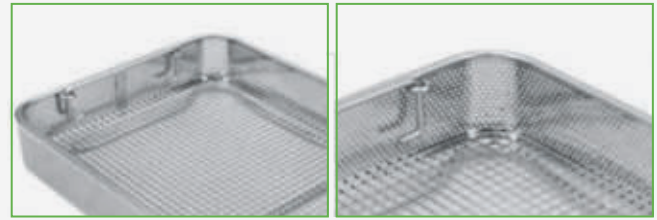

21-559-01 540x255x50 mm

21-559-02 540x255x70 mm

21-559-03 540x255x100 mm

Wire basket

21-560-01 485x255x50 mm

21-560-02 485x255x70 mm

21-560-03 485x255x100 mm

Wire basket



21-563-01 405x255x50 mm

21-563-02 405x255x70 mm

21-563-03 405x255x100 mm

Wire basket



21-566-01 255x245x50 mm

21-566-02 255x245x70 mm

21-566-03 255x245x100 mm

Wire basket

Baskets



21-567-01 290 x 80 x 52 mm

21-567-02 460 x 80 x 52 mm

21-567-03 670 x 80 x 52 mm

Endoscope basket



21-568-00 640 x 150 x 77 mm

Endoscope basket



21-569-00 274 x 172 x 43 mm

Wire basket



21-570-00 267 x 125 x 50 mm

Wire basket



21-571-00 274 x 172 x 43 mm

Wire basket



21-572-00 267 x 125 x 50 mm

Wire basket



## Wire Baskets

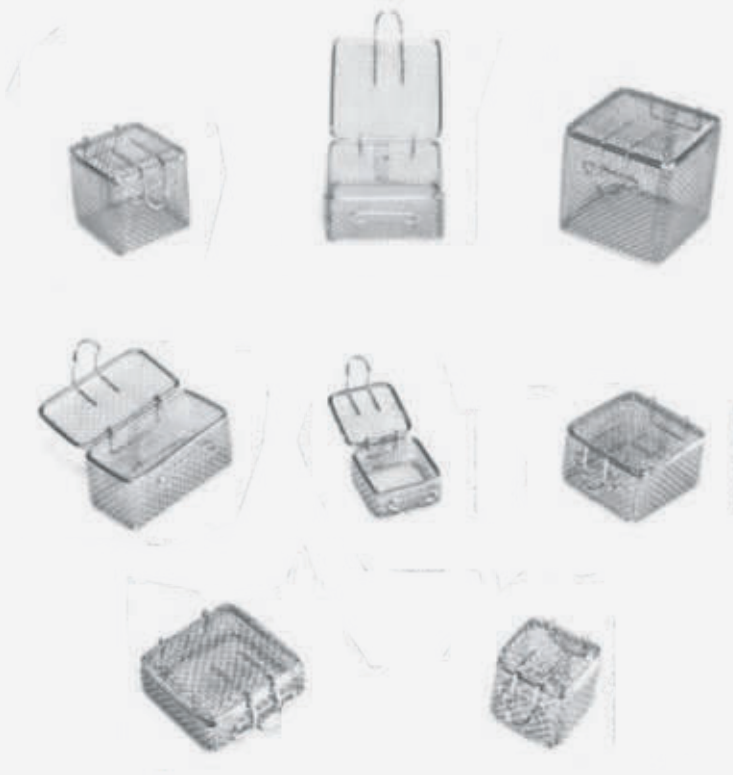

21-573-01	30 x 30 x 30 mm
21-573-02	40 x 40 x 20 mm
21-573-03	40 x 40 x 40 mm
21-573-04	60 x 60 x 20 mm
21-573-05	60 x 60 x 40 mm
21-573-06	60 x 60 x 60 mm
21-573-07	80 x 80 x 20 mm
21-573-08	80 x 40 x 40 mm
21-573-09	80 x 80 x 40 mm
21-573-10	80 x 80 x 60 mm
21-573-11	80 x 80 x 80 mm
21-573-12	100 x 100 x 10 mm
21-573-13	120 x 120 x 30 mm
21-573-14	120 x 120 x 60 mm
21-573-15	120 x 120 x 80 mm
21-573-16	240 x 240 x 30 mm
21-573-17	240 x 240 x 60 mm
21-573-18	240 x 240 x 80 mm
21-573-19	240 x 240 x 100 mm

Small fine mesh basket with lid  
Mesh distance, 2 x 2 mm



21-574-01 600 x 400 x 150 mm

21-574-02 600 x 400 x 300 mm

Laundry basket



21-575-01 600 x 400 x 150 mm

21-575-02 600 x 400 x 300 mm

Laundry basket

**Baskets**



Size: 1/1

Box and lid	Box only	Lid only	
21-576-01	21-577-01	21-578-01	540 x 253 x 30 mm
21-576-02	21-577-02	21-578-02	540 x 253 x 50 mm
21-576-03	21-577-03	21-578-03	540 x 253 x 70 mm
21-576-04	21-577-04	21-578-04	540 x 253 x 100 mm



Size: 1/1

Box and lid	Box only	Lid only	
21-579-01	21-580-01	21-581-01	485 x 253 x 30 mm
21-579-02	21-580-02	21-581-02	485 x 253 x 50 mm
21-579-03	21-580-03	21-581-03	485 x 253 x 70 mm
21-579-04	21-580-04	21-581-04	485 x 253 x 100 mm



Size: 3/4

Box and lid	Box only	Lid only	
21-582-01	21-583-01	21-584-01	405 x 253 x 30 mm
21-582-02	21-583-02	21-584-02	405 x 253 x 50 mm
21-582-03	21-583-03	21-584-03	405 x 253 x 70 mm
21-582-04	21-583-04	21-584-04	405 x 253 x 100 mm



Size: 1/2

Box and lid	Box only	Lid only	
21-585-01	21-586-01	21-587-01	244 x 253 x 30 mm
21-585-02	21-586-02	21-587-02	244 x 253 x 50 mm
21-585-03	21-586-03	21-587-03	244 x 253 x 70 mm
21-585-04	21-586-04	21-587-04	244 x 253 x 100 mm



Size: Dental

Box and lid	Box only	Lid only	
21-588-01	21-589-01	21-590-01	275 x 175 x 40 mm
21-588-02	21-589-02	21-590-02	275 x 175 x 95 mm



Size: Small

Box and lid	Box only	Lid only	
21-591-01	21-592-01	21-593-01	265 x 125 x 50 mm



21-594-14  
 Stand  
 14 mm height



21-595-20  
 Stand  
 20 mm height

Filters



21-596-00 210 x 95 mm

Long term textile filter for mini and dental container for 50 sterilization cycles.

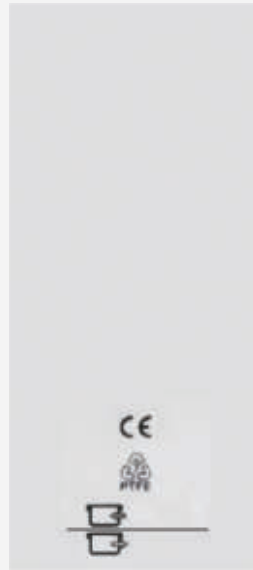

21-597-00 235 x 118 mm

Long term PTFE filter for mini and dental container for 1200 sterilization cycles.

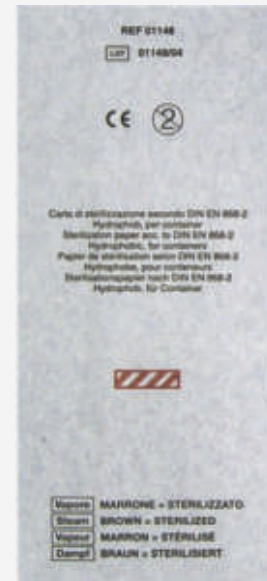

21-598-00 235 x 118 mm

Long term PTFE filter for 1/1, 1/2, 3/4, mini and dental container.



21-599-00 Ø 190 mm

Long term textil filter for 1/1, 1/2, 3/4 container for 50 sterilization cycles.



21-600-00 235 x 118 mm

Long term PTFE filter for 1/1, 1/2, 3/4 container for 1200 sterilization cycles.



21-601-00 235 x 118 mm

Disposable filter for 1/1, 1/2, 3/4 container.

Indicators, Labels and Drapes



**21-602-00**  
 Paper label with indicator  
 For 1/1, 1/2, 3/4 containers  
 Pack of 100



**21-602-00**  
 Paper label with indicator  
 For mini and dental containers  
 Pack of 100



**21-602-00**  
 Heavy duty clip  
 Serrated jaws



**21-605-01** For paper filter  
**21-605-02** For textile filter  
 Filter tray

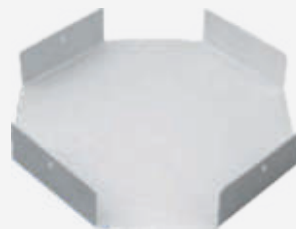

**21-606-00**  
 Filter dispenser



**21-607-00**  
 Plastic security seal  
 Pack of 100



**21-607-00**  
 Dispenser for  
 identification labels

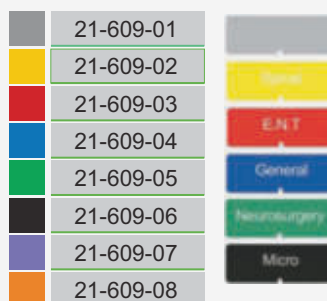

Coloured identification labels.  
 Printed to your specification,  
 16 letters max.



Drape

21-610-01	60 x 40 cm
21-610-02	65 x 65 cm
21-610-03	85 x 85 cm
21-610-04	90 x 60 cm
21-610-05	90 x 80 cm
21-610-06	130 x 45 cm
21-610-07	130 x 60 cm
21-610-08	140 x 100 cm
21-610-09	185 x 45 cm
21-610-10	185 x 60 cm

## Wire Base, Drape Retainer, Metal Labels and Fixation Clamps



Wire Base

21-611-01	255 x 245 x 30 mm
21-611-02	405 x 255 x 30 mm
21-611-03	545 x 255 x 30 mm



Drape Retainer

21-612-01	280 x 125 mm
21-612-02	310 x 190 mm
21-612-03	255 x 245 mm
21-612-04	405 x 255 mm
21-612-05	545 x 255 mm



Metal Label for Wire Basket

21-613-00	545 x 255 x 30 mm
-----------	-------------------

Unlabeled



Metal Label for Wire Basket

21-614-00	545 x 255 mm
-----------	--------------

Labeled



21-615-01
24 x 28 x 25 mm
Ø 7 - 12 mm



21-615-02
24 x 28 x 29 mm
Ø 12 - 16 mm



21-615-03
24 x 28 x 31 mm
Ø 16 - 26 mm



21-615-04
24 x 28 x 40 mm
Ø 26 - 36 mm



21-615-05
24 x 28 x 44 mm
Ø 36 - 45 mm



21-616-01
50 x 20 x 12 mm



21-616-02
65 x 20 x 20 mm



## Tray Tags



White	21-617-01
Blue	21-617-02
Red	21-617-03
Light Blue	21-617-04
Black	21-617-05

Green	21-617-01
Grey	21-617-02
Purple	21-617-03
Yellow	21-617-04
Beige	21-617-05

Nylon  
 Size: 105x40mm  
 Pack of 100



21-618-00
Stainless steel
Attachment ring
Ø 30 mm
Pack of 100

## Components



21-619-00

Holding pin for  
partition sheets



21-620-00

Holding pin for  
wire baskets

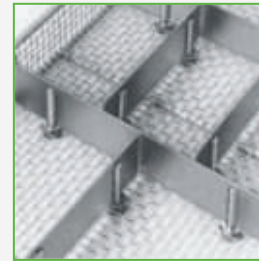

21-621-01 50 x 20 mm

21-621-02 130 x 20 mm

21-621-03 225 x 20 mm

21-621-04 460 x 20 mm

Sheets



21-622-01 230 mm

21-622-02 470 mm

Sliding rails with securing screws



21-623-01 230 mm

21-623-02 470 mm

Limiting bar with securing screws



21-624-00

Divider, to be used  
with 21-622-01 and 21-622-02



21-625-00

Spiral holding



21-626-00

Double spiral holding

Silicone Mats



Silicone Mat Fig. 1

21-627-01	270 x 125 mm
21-627-02	245 x 245 mm
21-627-03	220 x 230 mm
21-627-04	380 x 230 mm
21-627-05	440 x 230 mm
21-627-06	520 x 230 mm

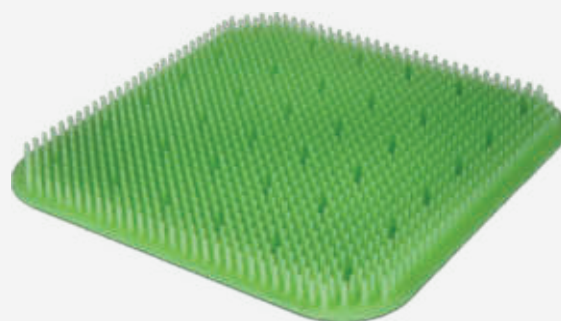

Silicone Mat Fig. 2

21-628-01	270 x 125 mm
21-628-02	245 x 245 mm
21-628-03	220 x 230 mm
21-628-04	380 x 230 mm
21-628-05	440 x 230 mm
21-628-06	520 x 230 mm

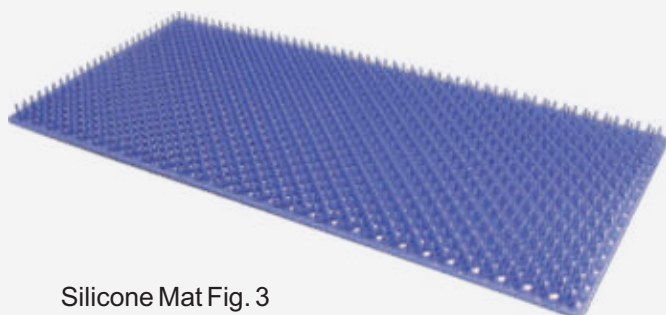

Silicone Mat Fig. 3

21-629-00	545 x 255 mm
-----------	--------------



Silicone Mat Fig. 4

21-630-01	220 x 125 mm
21-630-02	380 x 230 mm
21-630-03	440 x 230 mm
21-630-04	520 x 230 mm



Silicone Fixation System



	Length	Height
21-631-01	97 mm	41 mm
21-631-02	125 mm	41 mm
21-631-03	152 mm	41 mm
21-631-04	250 mm	41 mm

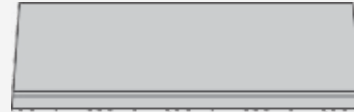
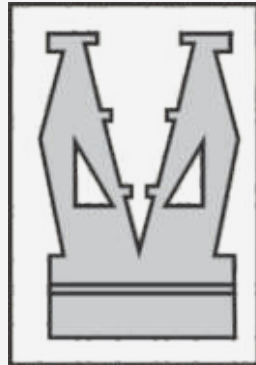

	Length	Height
21-632-01	90 mm	41 mm
21-632-02	120 mm	41 mm
21-632-03	150 mm	41 mm
21-632-04	240 mm	41 mm

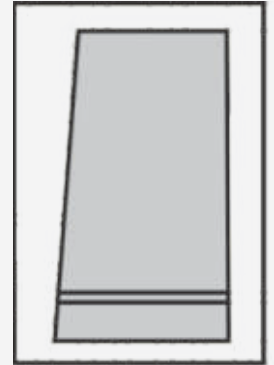

	Length	Height
21-633-01	87 mm	41 mm
21-633-02	119 mm	41 mm
21-633-03	150 mm	41 mm
21-633-04	238 mm	41 mm

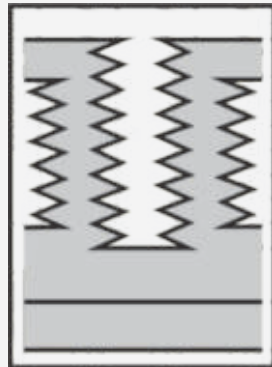

	Length	Height
21-634-01	77 mm	41 mm
21-634-02	112 mm	41 mm
21-634-03	158 mm	41 mm
21-634-04	238 mm	41 mm

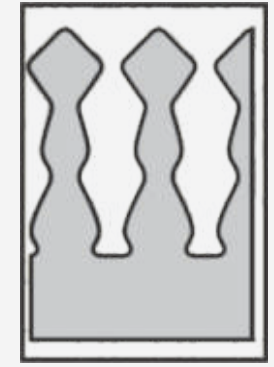

	Length	Height
21-635-00	178 mm	20 mm

Instruments holder from Ø 3 to 8 mm

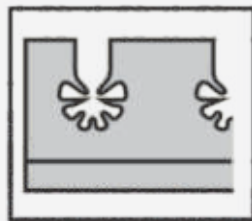

	Length	Height
21-636-00	73 mm	20 mm

Instruments holder from Ø 5

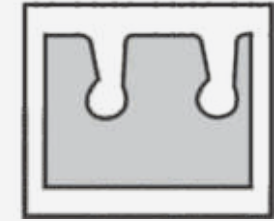

	Length	Height
21-637-00	73 mm	20 mm

Instruments holder from Ø 5

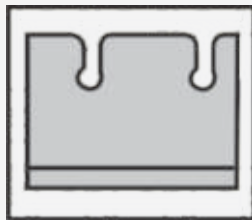

	Length	Height
21-638-00	178 mm	30 mm

Instruments holder from Ø 3 to 8 mm

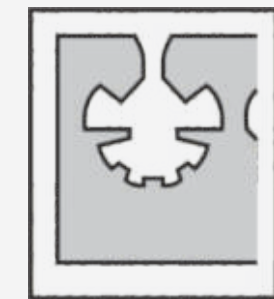

Silicone Fixation System

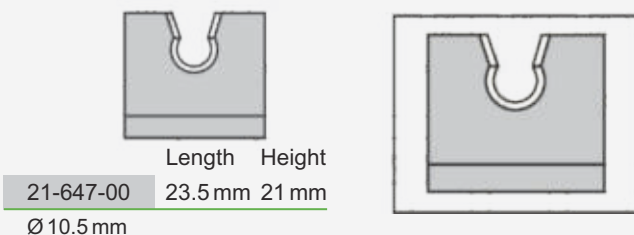
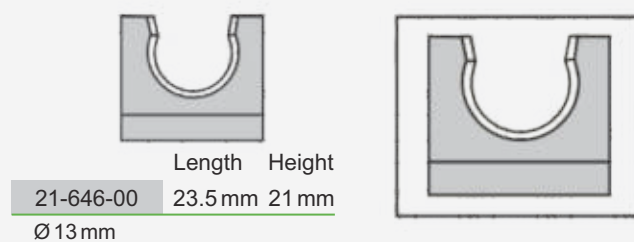
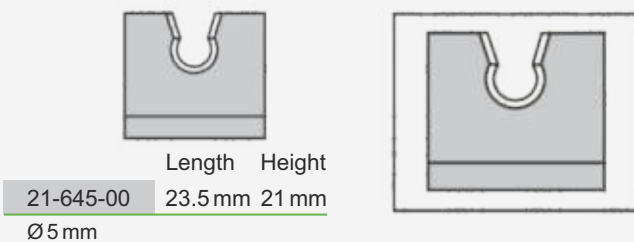
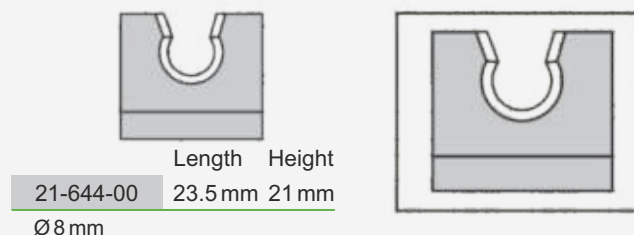
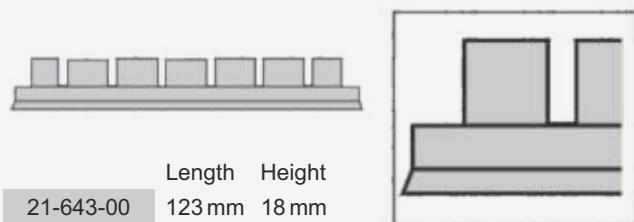
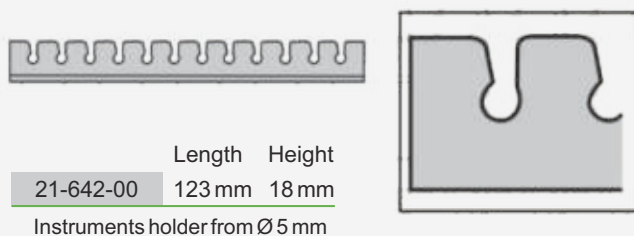
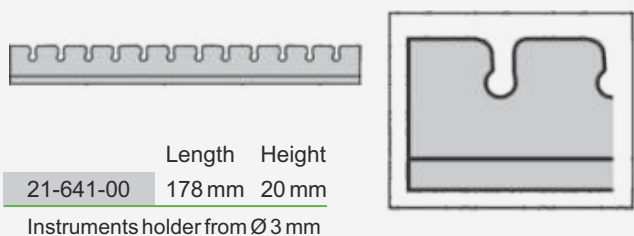
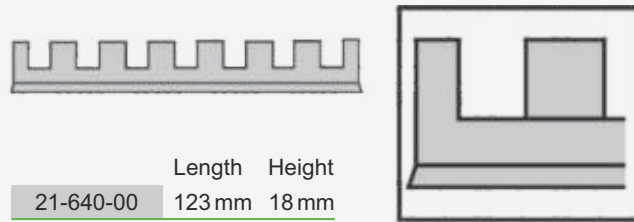
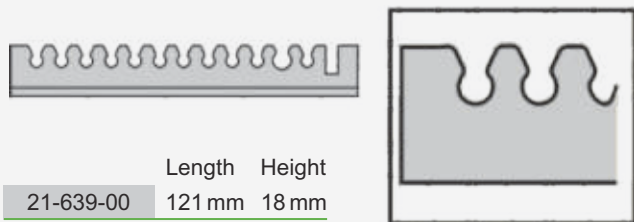

Silicone Fixation System

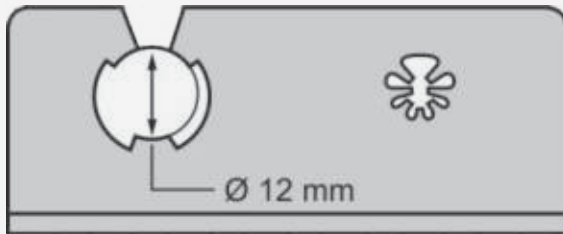

	Length	Height
21-648-00	73 mm	30 mm

Endoscope holder, double  
one side  $\varnothing$  15 mm open  
one side from  $\varnothing$  3 to  $\varnothing$  15 mm

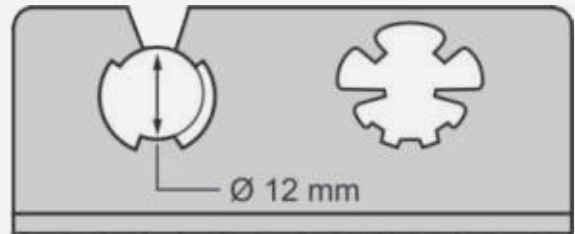

	Length	Height
21-649-00	72 mm	30 mm

Endoscope holder, double  
one side  $\varnothing$  15 mm open  
one side from  $\varnothing$  3 to  $\varnothing$  15 mm

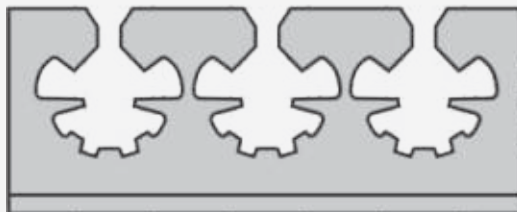

	Length	Height
21-650-00	72 mm	30 mm

Instruments holder  
from  $\varnothing$  3 to  $\varnothing$  15 mm



	Length	Height
21-651-00	72 mm	30 mm

Instruments holder  
from  $\varnothing$  3 to  $\varnothing$  8 mm



	Length	Height
21-652-00	38 mm	20 mm

Endoscope holder, double  
one side 12 mm open  
one side from  $\varnothing$  3 to  $\varnothing$  8 mm

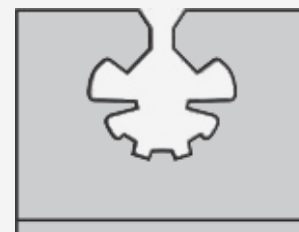

	Length	Height
21-638-00	72 mm	30 mm

Endoscope holder, double  
one side 12 mm open  
one side from  $\varnothing$  3 to  $\varnothing$  8 mm

Silicone Fixation System

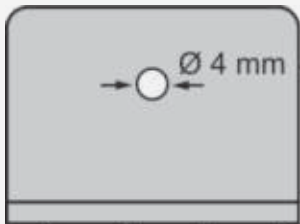

	Length	Height
21-654-00	54 mm	20 mm

Endoscope holder  
 Ø 4 mm closed

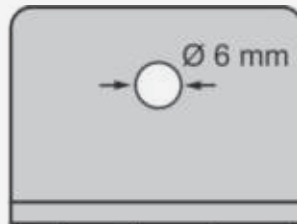

	Length	Height
21-655-00	38 mm	29 mm

Endoscope holder  
 Ø 6 mm closed

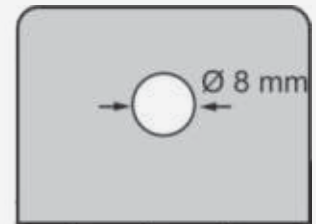

	Length	Height
21-656-00	38 mm	29 mm

Endoscope holder  
 Ø 8 mm closed



	Length	Height
21-657-00	38 mm	29 mm

Endoscope holder  
 Ø 12 mm closed

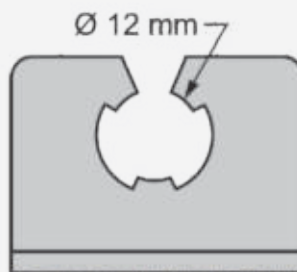

	Length	Height
21-658-00	38 mm	29 mm

Endoscope holder  
 Ø 12 mm open

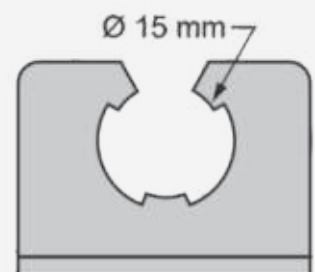

	Length	Height
21-659-00	38 mm	29 mm

Endoscope holder  
 Ø 15 mm open

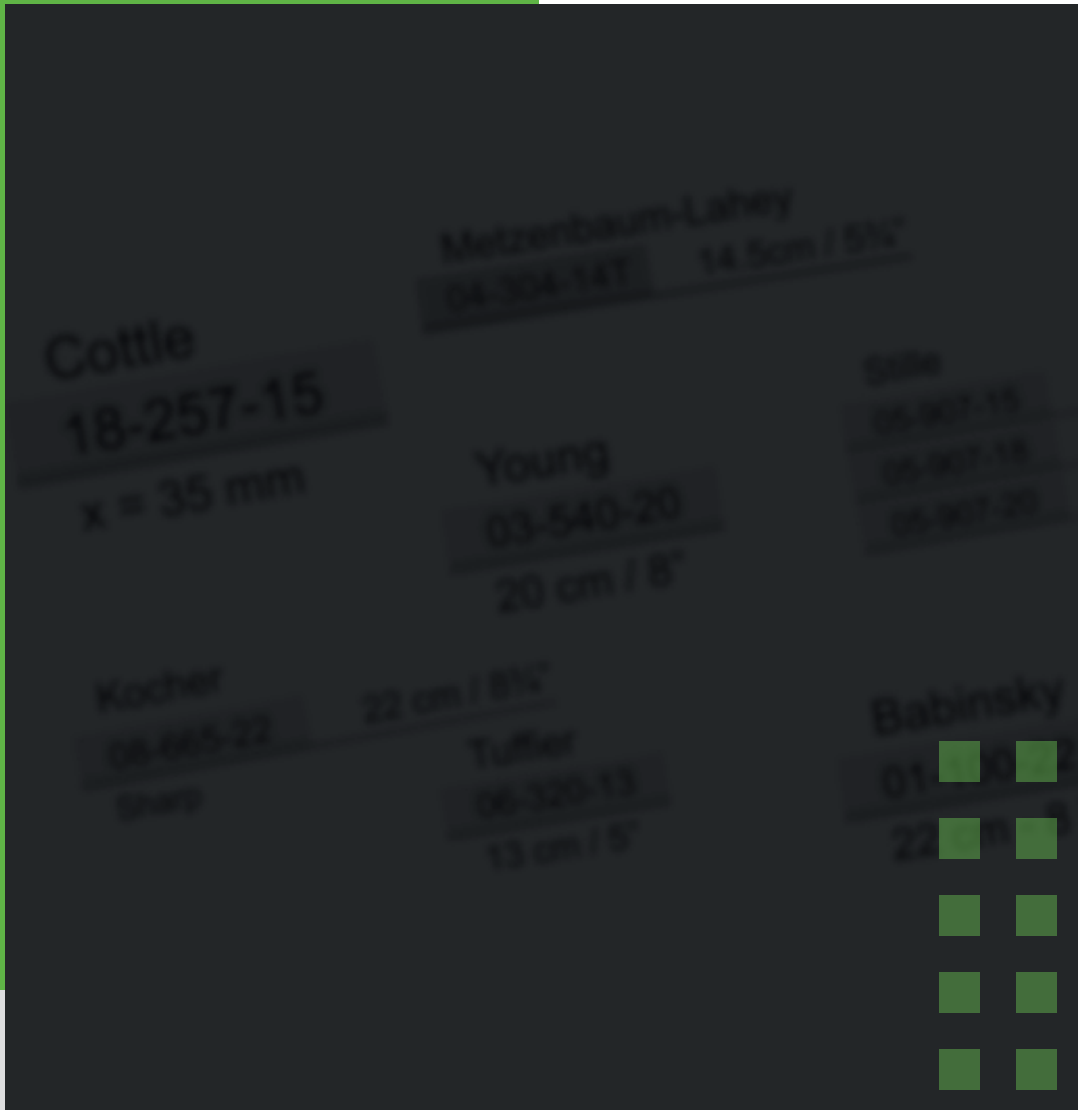

Numeric Index  
Numerischer Index  
Índice numérico  
Index numérique  
Indice numerico

comed  
operate better with us

NI



02-302-02	36
02-303-03	37
02-304-18	37
02-304-20	37
02-305-10	37
02-305-12	37
02-305-14	37
02-305-16	37
02-305-18	37
02-305-20	37
02-305-22	37
02-305-24	37
02-305-26	37
02-305-28	37
02-306-60	37
02-306-83	37
02-306-95	37
02-306-11	38
02-307-16	38
02-308-03	38
02-308-04	38
02-308-05	38
02-309-15	38
02-310-16	38
02-310-01	39
02-311-35	39
02-312-31	39
02-313-30	39
01-314-33	40
02-315-22	40
02-316-22	40
02-317-23	40
02-318-27	40
02-319-27	40
02-320-27	41
02-321-01	41
02-321-02	41
02-321-03	41
02-321-04	41
02-321-05	41
02-321-06	41
02-322-25	41
02-322-30	41
02-323-00	41
02-323-01	41
02-323-02	41
02-323-03	41
02-323-04	41
02-323-05	42
02-324-00	42
02-325-01	42
02-325-02	42
02-325-03	42
02-325-04	42
02-325-05	42
02-326-02	42
02-326-03	42
02-326-04	42
02-326-05	43
02-327-01	43
02-327-02	43

02-327-03	43
02-327-04	43
02-328-03	43
02-329-02	43
02-330-04	43
02-331-01	44
02-331-02	44
02-332-01	44
02-332-02	44
02-333-07	45
02-334-16	45
02-335-30	45
02-335-35	45
02-335-40	45
02-336-07	45
02-336-09	45
02-336-12	45
02-337-07	45
02-337-09	45
02-337-12	45
02-338-03	46
02-338-05	46
02-338-07	46
02-339-03	46
02-339-05	46
02-339-07	46
02-340-03	46
02-340-05	46
02-340-07	46
02-340-08	46
02-340-10	46
02-340-12	46
02-340-14	46
02-341-03	46
02-341-05	46
02-341-07	46
02-341-08	46
02-341-10	46
02-341-12	46
02-341-14	46
02-342-06	46
02-342-07	46
02-342-08	46
02-342-09	46
02-342-10	46
02-342-12	46
02-342-15	46
02-343-06	47
02-343-07	47
02-343-08	47
02-343-09	47
02-343-10	47
02-343-12	47
02-343-15	47
02-344-06	47
02-344-07	47
02-344-08	47
02-343-09	47
02-344-10	47
02-344-12	47
02-344-15	47

02-345-12	47
02-345-15	47
02-346-20	47
02-347-08	48
02-347-10	48
02-347-12	48
02-347-14	48
02-347-16	48
02-347-18	48
02-348-06	48
02-348-08	48
02-348-10	48
02-348-12	48
02-348-14	48
02-348-16	48
02-348-18	48
02-349-08	48
02-349-10	48
02-349-12	48
02-349-14	48
02-349-16	48
02-349-18	48
02-350-01	49
02-350-02	49
02-350-12	49
02-350-14	49
02-350-16	49
02-350-18	49
02-351-01	50
02-351-02	50
02-351-03	50
02-351-04	50
02-351-05	50
02-351-06	50
02-351-07	50
02-352-01	50
02-352-02	50
02-352-03	50
02-353-01	50
02-353-02	50
02-354-00	50
02-355-01	50
02-355-02	50
02-355-03	50
02-356-01	51
02-356-02	51
02-356-03	51
02-356-04	51
02-356-05	51
02-356-06	51
02-356-07	51
02-356-08	51
02-357-01	51
02-357-02	51
02-358-00	51
02-359-00	51
02-360-01	52
02-360-02	52
02-361-01	53
02-361-02	53
02-361-03	53

02-361-04	53
02-362-01	53
02-362-02	53
02-362-03	53
02-362-04	53
02-363-01	54
02-363-02	54
02-363-05	54
02-363-10	54
02-363-20	54
02-363-50	54
02-364-01	54
02-364-02	54
02-364-05	54
02-364-10	54
02-364-20	54
02-364-50	54
02-365-01	54
02-365-02	54
02-365-05	54
02-365-10	54
02-365-20	54
02-365-50	54
02-366-01	54
02-366-02	54
02-366-05	54
02-366-10	54
02-366-20	54
02-366-50	54
02-367-01	54
02-367-02	54
02-367-05	54
02-368-01	54
02-368-02	54
02-368-05	54
02-369-00	54
02-370-50	54
02-370-75	54
02-370-100	54
02-370-150	54
02-370-200	54
02-371-50	54
02-371-75	54
02-371-100	54
02-371-150	54
02-371-200	54
02-372-11	55
02-372-13	55
02-372-14	55
02-372-16	55
02-372-18	55
02-372-20	55
02-372-25	55
02-373-11	55
02-373-13	55
02-373-14	55
02-373-16	55
02-373-18	55
02-373-20	55
02-373-25	55
02-374-11	55

02-374-13	55
02-374-14	55
02-374-16	55
02-374-18	55
02-374-20	55
02-374-25	55
02-375-11	55
02-375-13	55
02-375-14	55
02-375-16	55
02-375-18	55
02-375-20	55
02-375-25	55
02-376-11	55
02-376-13	55
02-376-14	55
02-376-16	55
02-377-11	55
02-377-13	55
02-377-14	55
02-377-16	55
02-377-18	55
02-377-20	55
02-378-11	55
02-378-13	55
02-378-14	55
02-378-16	55
02-378-18	55
02-378-20	55
02-379-14	55
02-380-16	55
02-381-12	56
02-381-14	56
02-381-16	56
02-381-18	56
02-381-23	56
02-382-12	56
02-382-14	56
02-382-16	56
02-382-18	56
02-382-23	56
02-383-12	56
02-383-14	56
02-383-16	56
02-383-18	56
02-383-23	56
02-384-12	56
02-384-14	56
02-384-16	56
02-384-18	56
02-385-12	56
02-385-14	56
02-385-16	56
02-385-18	56
02-386-12	56
02-386-14	56
02-386-16	56
02-386-18	56
02-387-28	56
02-388-28	56
02-389-14	57

02-389-18	57
02-390-28	57
02-391-23	58

### 03

Scalpels – Knives	
Skalpelle – Messer	
Bisturís – Cuchillos	
Scalpels – Couteaux	
Bisturi – Coltelli	
03-500-01	60
03-500-02	60
03-501-01	60
03-501-02	60
03-501-03	60
03-501-04	60
03-501-05	60
03-501-06	60
03-501-07	60
03-501-08	60
03-501-09	60
03-501-10	60
03-505-03	61
03-509-03	61
03-502-04	61
03-506-01	61
03-503-01	61
03-504-08	62
03-507-07	62
03-508-07	62
03-510-03	62
03-511-03	62
03-512-10	63
03-512-11	63
03-512-12	63
03-512-12D	63
03-512-15	63
03-515-12C	63
03-512-18	63
03-512-20	63
03-512-21	63
03-512-22	63
03-512-23	63
03-512-24	63
03-513-13	64
03-513-03	64
03-513-04	64
03-513-07	64
03-513-09	64
03-513-64	64
03-513-65	64
03-513-67	64
03-513-69	64
03-514-13	64
03-515-15	64
03-516-18	64
03-517-20	64
03-518-21	64
03-518-25	64
03-519-13	65

03-520-09	65
03-521-09	65
03-522-24	65
03-523-24	65
03-524-09	66
03-525-09	66
03-526-12	66
03-527-13	66
03-528-18	66
03-529-00	66
03-530-25	67
03-531-25	67
03-532-26	67
03-532-29	67
03-532-31	67
03-533-26	67
03-533-33	67
03-533-38	67
03-534-13	68
03-534-16	68
03-534-19	68
03-534-22	68
03-535-29	68
03-536-05	68
03-537-05	68
03-538-12	68
03-539-08	69
03-540-20	69
03-541-30	69
03-542-01	69
03-543-02	69
03-544-00	70
03-545-31	70
03-546-30	70
03-548-30	70
03-547-19	70

### 04

Scissors	
Schere	
Tijeras	
Ciseaux	
Forbici	
04-180-10	72
04-180-11	72
04-180-13	72
04-180-14	72
04-180-15	72
04-180-16	72
04-180-17	72
04-180-18	72
04-180-20	72
04-181-10	72
04-181-11	72
04-181-13	72
04-181-14	72
04-181-15	72
04-181-16	72
04-181-17	72
04-181-18	72

04-181-20	72
04-182-10	72
04-182-11	72
04-182-13	72
04-182-14	72
04-182-15	72
04-182-16	72
04-182-17	72
04-182-18	72
04-182-20	72
04-183-14T	72
04-183-16T	72
04-184-14T	72
04-184-16T	72
04-185-14T	72
04-185-16T	72
04-186-14S	72
04-186-13S	72
04-187-14S	72
04-187-13S	72
04-188-14S	72
04-188-13S	72
04-189-11	73
04-189-13	73
04-189-14	73
04-189-15	73
04-189-16	73
04-189-17	73
04-189-18	73
04-189-20	73
04-190-11	73
04-190-13	73
04-190-14	73
04-190-15	73
04-190-16	73
04-190-17	73
04-190-18	73
04-190-20	73
04-191-11	73
04-191-13	73
04-191-14	73
04-191-15	73
04-191-16	73
04-191-17	73
04-191-18	73
04-191-20	73
04-192-14T	73
04-192-16T	73
04-193-14T	73
04-193-16T	73
04-194-14T	73
04-194-16T	73
04-195-14S	73
04-196-14S	73
04-194-16S	73
04-197-13	74
04-197-14	74
04-197-13T	74
04-197-13S	74
04-198-13	74
04-198-14	74



04-198-13T	74
04-198-13S	74
04-199-13	74
04-199-14	74
04-199-13T	74
04-199-13S	74
04-200-13	74
04-200-14	74
04-200-14T	74
04-200-14S	74
04-201-13	74
04-201-14	74
04-201-14T	74
04-201-14S	74
04-202-13	74
04-202-14	74
04-202-14T	74
04-202-14S	74
04-203-14	75
04-204-14	75
04-205-14	75
04-206-14	75
04-207-15	75
04-208-15	75
04-209-15	75
04-210-15	75
04-211-16	76
04-211-21	76
04-212-16	76
04-212-21	76
04-213-16T	76
04-213-21T	76
04-214-16T	76
04-214-21T	76
04-215-16S	76
04-215-21S	76
04-216-16S	76
04-216-21S	76
04-217-10	76
04-218-10	76
04-219-10	76
04-220-10	76
04-221-13	76
04-221-14	76
04-221-16	76
04-222-16	76
04-223-14	77
04-223-16	77
04-223-18	77
04-224-14	77
04-225-12	77
04-226-14	77
04-227-14	77
04-228-14	77
04-229-14	77
04-230-14	78
04-230-15	78
04-230-17	78
04-230-20	78
04-230-23	78
04-230-28	78

04-231-14	78
04-231-15	78
04-231-17	78
04-231-20	78
04-231-23	78
04-231-28	78
04-232-15	78
04-232-17	78
04-232-19	78
04-232-21	78
04-232-23	78
04-233-15	78
04-233-17	78
04-233-19	78
04-233-21	78
04-233-23	78
04-233-15B	78
04-233-17B	78
04-233-19B	78
04-233-21B	78
04-233-23B	78
04-234-14T	78
04-234-17T	78
04-234-23T	78
04-335-14T	78
04-335-17T	78
04-335-23T	78
04-236-14S	78
04-236-17S	78
04-236-23S	78
04-236-25S	78
04-237-14S	78
04-237-17S	78
04-237-23S	78
04-237-25S	78
04-238-15T	78
04-238-17T	78
04-239-15T	78
04-239-17T	78
04-240-17T	78
04-241-15S	78
04-241-17S	78
04-242-15S	78
04-242-17S	78
04-243-16T	79
04-244-16T	79
04-245-16S	79
04-246-16S	79
04-247-18S	79
04-248-23S	79
04-249-20	79
04-249-23	79
04-250-20	79
04-250-23	79
04-249-20T	79
04-249-23T	79
04-249-30S	79
04-250-20T	79
04-250-23T	79
04-250-30S	79
04-351-17	79

04-352-17	79
04-249-23	80
04-250-23	80
04-251-23	80
04-252-23	80
04-253-23	80
04-254-23T	80
04-254-28T	80
04-254-32T	80
04-255-23T	80
04-255-28T	80
04-255-32T	80
04-256-23T	80
04-256-28T	80
04-256-32T	80
04-257-23T	80
04-257-28T	80
04-257-32T	80
04-258-23T	80
04-258-28T	80
04-259-14	81
04-259-15	81
04-259-18	81
04-259-20	81
04-259-23	81
04-259-25	81
04-259-28	81
04-259-30	81
04-260-14	81
04-261-14	81
04-261-18	81
04-262-14	81
04-262-18	81
04-262-20	81
04-262-23	81
04-263-14	81
04-263-15	81
04-263-18	81
04-263-20	81
04-263-23	81
04-263-25	81
04-263-28	81
04-263-30	81
04-264-14	81
04-265-14	81
04-265-18	81
04-265-20	81
04-266-14	81
04-266-18	81
04-266-20	81
04-266-23	81
04-266-11T	82
04-266-14T	82
04-266-18T	82
04-266-20T	82
04-267-23T	82
04-267-25T	82
04-267-28T	82
04-267-30T	82
04-268-11S	82

04-268-14S	82
04-268-16S	82
04-269-18S	82
04-269-20S	82
04-270-14T	82
04-271-14T	82
04-272-14T	82
04-272-18T	82
04-272-20T	82
04-272-23T	82
04-272-25T	82
04-272-28T	82
04-273-14S	82
04-273-17S	82
04-273-18S	82
04-274-14T	82
04-274-18T	82
04-274-23T	82
04-275-11T	83
04-275-14T	83
04-275-18T	83
04-275-20T	83
04-275-23T	83
04-275-25T	83
04-275-28T	83
04-275-30T	83
04-275-33T	83
04-275-36T	83
04-275-38T	83
04-276-23S	83
04-276-25S	83
04-276-28S	83
04-276-30S	83
04-276-36S	83
04-277-14T	83
04-278-14T	83
04-279-14T	83
04-279-18T	83
04-279-20T	83
04-279-23T	83
04-279-25T	83
04-279-28T	83
04-280-14S	83
04-280-17S	83
04-280-18S	83
04-281-14T	83
04-281-18T	83
04-281-23T	83
04-281-28T	83
04-281-33T	83
04-281-36T	83
04-282-14T	83
04-282-18T	83
04-282-20T	83
04-282-23T	83
04-282-25T	83
04-283-14T	83
04-283-18T	83
04-284-20T	83
04-284-23T	83
04-284-28T	83

04-284-18	84	04-288-26S	85	04-329-23T	87	04-364-12	91
04-284-20	84	04-288-30S	85	04-330-18T	87	04-365-12	91
04-284-23	84	04-290-18T	85	04-330-20T	87	04-366-12	91
04-284-26	84	04-290-20T	85	04-330-23T	87	04-367-12	91
04-284-28	84	04-290-23T	85	04-331-18T	87	04-368-12	91
04-284-30	84	04-290-26T	85	04-331-20T	87	04-369-12	91
04-285-18	84	04-290-28T	85	04-331-23T	87	04-370-10	91
04-285-20	84	04-290-30T	85	04-332-12	88	04-371-12	92
04-285-23	84	04-291-18T	85	04-333-12S	88	04-372-12	92
04-285-26	84	04-291-20T	85	04-334-19	88	04-373-12	92
04-285-28	84	04-291-23T	85	04-334-25S	88	04-374-12	92
04-285-30	84	04-291-26T	85	04-335-21	88	04-375-12	92
04-286-18	84	04-291-28T	85	03-159-15	88	04-376-12	92
04-286-20	84	04-291-30T	85	04-337-20	89	04-377-14	92
04-286-23	84	04-292-18T	85	04-337-23	89	04-378-14	92
04-286-26	84	04-292-20T	85	04-338-20	89	04-379-12	92
04-286-28	84	04-292-23T	85	04-338-23	89	04-379-14	92
04-286-30	84	04-292-26T	85	04-339-20	89	04-380-14	92
04-284-18A	84	04-292-28T	85	04-339-23	89	04-381-18	92
04-284-20A	84	04-292-30T	85	04-340-20	89	04-382-14	92
04-284-23A	84	04-293-23S	85	04-340-23	89	04-383-18	92
04-284-26A	84	04-293-26S	85	04-341-20T	89	04-384-16	93
04-284-28A	84	04-293-30S	85	04-341-23T	89	04-385-16	93
04-284-30A	84	04-291-23S	85	04-342-20T	89	04-386-16T	93
04-284-17B	84	04-291-26S	85	04-342-23T	89	04-387-16T	93
04-284-20B	84	04-291-30S	85	04-343-20T	89	04-388-12	93
04-284-23B	84	04-292-23S	85	04-343-23T	89	04-388-14	93
04-284-26B	84	04-292-26S	85	04-344-20T	89	04-388-16	93
04-284-28B	84	04-292-30S	85	04-344-23T	89	04-388-18	93
04-284-30B	84	04-294-09	86	04-345-20S	89	04-389-14T	93
04-285-17C	84	04-295-09S	86	04-345-23S	89	04-390-12S	93
04-285-20C	84	04-296-11	86	04-346-20S	89	04-390-16S	93
04-285-23C	84	04-297-11	86	04-346-23S	89	04-390-18S	93
04-285-26C	84	04-298-11T	86	04-347-20S	89	04-391-12	93
04-285-28C	84	04-299-11T	86	04-347-23S	89	04-391-14	93
04-285-30C	84	04-300-11S	86	04-348-20S	89	04-391-16	93
04-286-18T	85	04-301-11S	86	04-348-23S	89	04-391-18	93
04-286-20T	85	04-302-18S	86	04-349-27	89	04-392-14T	93
04-286-23T	85	04-302-20S	86	04-350-27	89	04-393-12S	93
04-286-26T	85	04-302-23S	86	04-351-16	89	04-393-16S	93
04-286-28T	85	04-303-14	86	04-351-18	89	04-393-18S	93
04-286-30T	85	04-325-14	87	04-352-16	89	04-394-15	93
04-287-18T	85	04-325-18	87	04-352-18	89	04-394-18	93
04-287-20T	85	04-325-22	87	04-353-18T	89	04-394-14T	93
04-287-23T	85	04-325-23	87	04-354-18T	89	04-396-14S	93
04-287-26T	85	04-326-14	87	04-304-14	90	04-396-18S	93
04-287-28T	85	04-326-18	87	04-304-20	90	04-396-25S	93
04-287-30T	85	04-326-22	87	04-304-23	90	04-396-28S	93
04-288-18T	85	04-326-23	87	04-305-14	90	04-397-12	94
04-288-20T	85	04-327-14	87	04-305-20	90	04-398-12	94
04-288-23T	85	04-327-18	87	04-305-23	90	04-399-14	94
04-288-26T	85	04-327-22	87	04-355-25	90	04-400-14	94
04-288-28T	85	04-327-23	87	04-356-24	90	04-401-12	94
04-288-30T	85	04-304-14T	87	04-357-22	90	04-402-10	94
04-289-23S	85	04-328-14T	87	04-358-12	91	04-403-10	95
04-289-26S	85	04-328-18T	87	04-359-12	91	04-404-10	95
04-289-30S	85	04-328-20T	87	04-360-12	91	04-404-12	95
04-287-23S	85	04-328-23T	87	04-361-12	91	04-405-12	95
04-287-26S	85	04-329-14T	87	04-362-12	91	04-407-12T	95
04-287-30S	85	04-329-18T	87	04-363-12	91	04-408-12T	95
04-288-23S	85	04-329-20T	87			04-409-12S	95

04-410-12S	95
04-411-12	95
04-412-12	95
04-413-12	95
04-414-12	95
04-415-12S	95
04-412-12S	95
04-416-12S	95
04-414-12S	95
04-417-10	95
04-418-10	95
04-419-09	95
04-420-11T	96
04-421-11T	96
04-422-11S	96
04-423-11S	96
04-424-12	96
04-425-12S	96
04-427-14T	96
04-428-14T	96
04-429-14T	96
04-430-14T	96
04-431-14S	96
04-432-14S	96
04-433-14S	96
04-434-14S	96
04-435-13	96
04-436-13	96
04-437-13T	96
04-438-13T	96
04-439-13S	96
04-440-09	97
04-441-10	97
04-444-11	97
04-426-11T	97
04-449-14	98
04-450-14	98
04-451-14T	98
04-452-14T	98
04-453-14S	98
04-454-14S	98
04-455-14	98
04-456-14	98
04-457-08	98
04-458-08	98
04-459-13	98
04-460-12	98
04-460-15	98
04-460-18	98
04-461-12T	98
04-461-15T	98
04-461-18T	98
04-462-12S	98
04-462-15S	98
04-462-18S	98
04-462-20S	98
04-462-23S	98
04-463-11	98
04-464-13	99
04-465-13	99
04-466-13S	99

04-467-13S	99
04-470-12T	99
04-471-18T	99
04-472-16S	99
04-473-16	100
04-473-18	100
04-474-16	100
04-474-18	100
04-475-16	100
04-475-18	100
04-473-16T	100
04-476-16T	100
04-477-16T	100
04-479-16S	100
04-480-09	100
04-480-11	100
04-481-09	100
04-481-11	100
04-482-11	100
04-483-11	100
04-484-12	100
04-485-12	100
04-486-12	100
04-487-12	100
04-488-17T	101
04-488-19T	101
04-488-23T	101
04-489-17T	101
04-489-19T	101
04-489-23T	101
04-490-17S	101
04-490-19S	101
04-490-23S	101
04-491-17S	101
04-491-19S	101
04-491-23S	101
04-492-17T	101
04-492-19T	101
04-492-23T	101
04-493-17S	101
04-493-19S	101
04-493-23S	101
04-499-15T	101
04-499-19T	101
04-499-23T	101
04-500-15S	101
04-500-17S	101
04-500-19S	101
04-500-23S	101
04-502-11	102
04-503-11T	102
04-504-11S	102
04-505-11S	102
04-504-19T	102
04-507-19T	102
04-508-18T	102
04-510-18S	102
04-511-14	103
04-512-11	103
04-513-11	103
04-514-11	103

04-515-11	103
04-516-17	103
04-517-17	103
04-518-17	103
04-519-45	103
04-519-60	103
04-520-25	104
04-520-28	104
04-521-14	104
04-522-17	104
04-523-08S	104
04-523-12S	104
04-524-18	104
04-525-16	105
04-525-23	105
04-525-28	105
04-526-16	105
04-526-23	105
04-526-28	105
04-527-16	105
04-527-23	105
04-527-28	105
04-528-15	105
04-529-15	105
04-530-16T	105
04-530-23T	105
04-530-28T	105
04-531-16T	105
04-531-23T	105
04-531-28T	105
04-532-16T	105
04-532-23T	105
04-532-28T	105
04-533-22	105
04-534-19	106
04-535-19	106
04-536-19	106
04-537-19	106
04-538-19T	106
04-539-19T	106
04-540-19T	106
04-541-12	107
04-541-14	107
04-542-12	107
04-542-14	107
04-543-12	107
04-543-14	107
04-544-12T	107
04-544-14T	107
04-545-12T	107
04-545-14T	107
04-546-12T	107
04-546-14T	107
04-547-12S	107
04-547-14S	107
04-548-12S	107
04-548-14S	107
04-549-12S	107
04-549-14S	107
04-550-12	107
04-550-14	107

04-551-12	107
04-551-14	107
04-552-12T	107
04-552-14T	107
04-553-12T	107
04-553-14T	107
04-554-12S	107
04-554-14S	107
04-553-12S	107
04-553-14S	107
04-560-18	108
04-561-18	108
04-562-18	108
04-563-18	108
04-564-18	108
04-565-18	108
04-566-18	108
04-567-18	108
04-568-18	108
04-569-18	108
04-570-18	108
04-571-14	108
04-572-13	108
04-573-19	109
04-574-19	109
04-575-19	109
04-576-19	109
04-577-19	109
04-578-19T	109
04-579-19T	109
04-580-19T	109
04-581-19S	109
04-582-19S	109
04-583-19S	109
04-584-12	110
04-589-19	110
04-590-01	110
04-590-02	110
04-591-19	110
04-592-18	111
04-593-18	111
04-594-18	111
04-595-18	111
04-596-18	111
04-597-17	111
04-598-17	111
04-599-17T	111
04-600-17T	111
04-601-17S	111
04-602-17S	111
04-603-20	112
04-604-20T	112
04-604-23T	112
04-605-19	112
04-606-17	112
04-607-17	112
04-608-17T	112
04-609-17S	112
04-610-30	113
04-611-25	113
04-611-28	113

04-612-25	113	04-666-14S	121	04-708-11S	125	04-740-18	129
04-612-28	113	04-667-14	121	04-709-11S	125	04-742-15	129
04-613-25	113	04-668-14	121	04-710-11S	125	04-747-09	130
04-614-25S	113	04-669-16	121	04-711-10	126	04-747-12	130
04-615-27	113	04-670-11	122	04-711-11	126	04-748-15	130
04-616-18	114	04-671-10	122	04-712-10	126	04-749-12	130
04-617-24	114	04-672-10	122	04-712-11	126	04-750-11	130
04-618-23	114	04-673-13	122	04-713-11T	126	04-751-10	130
04-619-23	114	04-674-11	122	04-714-11T	126	04-120-11	130
04-620-21	115	04-675-16	122	04-715-10S	126	04-121-14	130
04-621-21	115	04-676-16	122	04-715-11S	126	04-122-11	130
04-622-21	115	04-677-18	123	04-715-13S	126	04-753-12	131
04-623-31	115	04-678-18	123	04-716-10S	126	04-754-12T	131
04-624-32	115	04-679-22	123	04-716-11S	126	04-756-12	131
04-625-27	115	04-680-22	123	04-716-13S	126	04-757-12	131
04-626-13	116	04-681-22T	123	04-717-10	126	04-761-10	132
04-626-16	116	04-682-22T	123	04-717-11	126	04-761-12	132
04-627-13	116	04-683-20	123	04-718-10	126	04-762-10	132
04-627-16	116	04-684-20T	123	04-718-11	126	04-762-12	132
04-628-16T	116	04-685-13	124	04-719-11T	126	04-763-10	132
04-629-16T	116	04-686-13	124	04-720-11T	126	04-763-12	132
04-629-16	116	04-687-13	124	04-721-10S	126	04-764-10	132
04-630-10	116	04-685-21	124	04-721-11S	126	04-764-12	132
04-631-14	117	04-686-21	124	04-721-13S	126	04-765-10	132
04-631-18	117	04-687-21	124	04-722-10S	126	04-765-12	132
04-631-22	117	04-688-09	125	04-722-11S	126	04-766-10	132
04-632-20	117	04-688-10	125	04-722-13S	126	04-766-12	132
04-634-20	117	04-688-11	125	04-723-18	126	04-767-10	132
04-635-20T	117	04-688-12	125	04-723-18S	126	04-767-12	132
04-636-20S	117	04-689-09	125	04-724-11	126	04-768-10	132
04-637-20	117	04-689-10	125	04-725-10	126	04-768-12	132
04-638-23S	117	04-689-11	125	04-726-10	126	04-494-01	133
04-639-17	118	04-689-12	125	04-727-11	127	04-494-02	133
04-640-17	118	04-690-11	125	04-727-13	127	04-494-03	133
04-641-18S	118	04-691-11	125	04-727-14	127	04-494-04	133
04-642-20	118	04-692-11	125	04-728-11	127	04-494-05	133
04-643-17	118	04-693-11	125	04-728-13	127	04-494-06	133
04-644-16	118	04-694-11T	125	04-728-14	127	04-494-07	133
04-645-16T	118	04-695-11T	125	04-826-13	127	04-494-08	133
04-646-16S	118	04-696-11T	125	04-826-15	127	04-494-09	133
04-647-15	119	04-697-10S	125	04-827-13	127	04-494-10	133
04-648-13	119	04-698-10S	125	04-827-15	127	04-494-11	133
04-649-13T	119	04-699-10S	125	04-729-14	128	04-494-12	133
04-650-13S	119	04-697-11S	125	04-730-17	128	04-769-01	133
04-651-14	119	04-698-11S	125	04-731-20	128	04-769-02	133
04-652-13	119	04-699-11S	125	04-732-20	128	04-769-03	133
04-652-23	119	04-697-13S	125	04-733-14	128	04-769-04	133
04-653-16T	119	04-698-13S	125	04-734-17	128	04-769-05	133
04-654-16S	119	04-699-13S	125	04-734-19	128	04-769-06	133
04-655-19	120	04-700-09	125	04-735-14	129	04-769-07	133
04-656-17	120	04-701-09	125	04-736-09	129	04-769-08	133
04-657-19	120	04-702-09S	125	04-737-09	129	04-769-09	133
04-658-14	120	04-703-11	125	04-737-10	129	04-769-10	133
04-659-14S	120	04-704-11	125	04-737-11	129	04-769-11	133
04-660-18	120	04-705-11	125	04-737-13	129	04-769-12	133
04-660-20	120	04-706-11	125	04-738-09	129	04-770-01	133
04-661-12	120	04-707-10S	125	04-738-10	129	04-770-02	133
04-662-13	121	04-708-10S	125	04-738-11	129	04-770-03	133
04-663-13T	121	04-709-10S	125	04-738-13	129	04-770-04	133
04-664-14	121	04-710-10S	125	04-739-11	129	04-770-05	133
04-665-14T	121	04-707-11S	125	04-740-14	129	04-770-06	133

04-770-07	133
04-770-08	133
04-770-09	133
04-770-10	133
04-770-11	133
04-770-12	133
04-116-01	133
04-116-02	133
04-116-03	133
04-116-04	133
04-116-05	133
04-116-06	133
04-116-07	133
04-117-01	133
04-117-02	133
04-117-03	133
04-117-04	133
04-117-05	133
04-117-06	133
04-117-07	133
04-118-01	133
04-118-02	133
04-118-03	133
04-118-04	133
04-118-05	133
04-118-06	133
04-118-07	133
04-112-01	133
04-112-02	133
04-112-03	133
04-112-04	133
04-112-05	133
04-112-06	133
04-113-01	133
04-113-02	133
04-113-03	133
04-113-04	133
04-113-05	133
04-113-06	133
04-114-01	133
04-114-02	133
04-114-03	133
04-114-04	133
04-114-05	133
04-114-06	133
04-771-09	134
04-771-11	134
04-771-14	134
04-771-18	134
04-771-20	134
04-771-25	134
04-771-30	134
04-772-14T	134
04-772-18T	134
04-772-20T	134
04-773-14S	134
04-773-18S	134
04-773-20S	134
04-774-18	134
04-774-20	134
04-775-20S	134

04-777-14	134
04-778-14	134
04-779-16	134
04-780-16	134
04-780-18	134
04-780-20	134
04-780-23	134
04-776-18	135
04-781-20	135
04-781-22	135
04-782-20S	135
04-782-22S	135
04-784-16	135
04-784-19	135
04-785-16S	135
04-786-18	135
04-787-23	135
04-788-23	135
04-789-24	136
04-790-24	136
04-791-24	136
04-792-24S	136
04-793-20	136
04-794-23	136
04-795-23	136
04-796-23	137
04-797-22	137
04-798-19	137
04-799-19	137
04-800-22	137
04-801-21	137
04-802-12	138
04-803-12	138
04-804-12	138
04-805-12	138
04-806-12	138
04-807-12	138
04-808-12	139
04-809-12	139
04-810-12	139
04-811-12	139
04-812-05	139
04-813-05	139
04-814-11	139
04-815-11	139
04-816-09	139
04-817-08	140
04-818-08	140
04-819-10	140
04-820-10	140
04-821-11	140
04-825-11	140

## 05

Dissecting - Tissue Forceps	
Präparieren - Gewebezange	
Dissección - Pinzas para tejidos	
Dissection - Pince à tissus	
Dissezione - Forcipe per tessuti	
05-901-08	142

05-901-10	142
05-901-11	142
05-901-13	142
05-901-14	142
05-901-15	142
05-901-16	142
05-901-18	142
05-901-20	142
05-901-25	142
05-901-30	142
05-901-35	142
05-902-08	142
05-902-10	142
05-902-11	142
05-902-13	142
05-902-14	142
05-902-15	142
05-902-16	142
05-902-18	142
05-902-20	142
05-902-25	142
05-902-30	142
05-902-35	142
05-903-08	142
05-903-10	142
05-903-11	142
05-903-13	142
05-903-14	142
05-903-15	142
05-903-16	142
05-903-18	142
05-903-20	142
05-903-25	142
05-903-30	142
05-903-35	142
05-901-24R	142
05-904-13	143
05-904-14	143
05-904-16	143
05-905-12	143
05-905-13	143
05-905-14	143
05-905-15	143
05-905-18	143
05-905-21	143
05-905-25	143
05-905-31	143
05-906-12	143
05-906-13	143
05-906-14	143
05-906-15	143
05-906-18	143
05-906-21	143
05-906-25	143
05-906-31	143
05-907-15	143
05-907-18	143
05-907-20	143
05-908-12	143
05-908-15	143
05-909-17	144

05-910-17	144
05-911-17	144
05-912-18	144
05-913-18	144
05-914-18	144
05-915-12	144
05-915-15	144
05-916-12	144
05-916-15	144
05-917-12	144
05-918-12	144
05-920-15	145
05-920-18	145
05-920-20	145
05-920-25	145
05-921-18	145
05-921-21	145
05-921-25	145
05-922-18	145
05-922-21	145
05-922-25	145
04-147-15	145
04-148-15	145
05-923-10	146
05-923-11	146
05-923-13	146
05-923-14	146
05-923-15	146
05-923-16	146
05-923-18	146
05-923-20	146
05-923-25	146
05-923-30	146
05-923-35	146
05-924-10	146
05-924-11	146
05-924-13	146
05-924-14	146
05-924-15	146
05-924-16	146
05-924-18	146
05-924-20	146
05-924-25	146
05-924-30	146
05-924-35	146
05-925-10	146
05-925-11	146
05-925-13	146
05-925-14	146
05-925-15	146
05-925-16	146
05-925-18	146
05-925-20	146
05-925-25	146
05-925-30	146
05-925-35	146
05-926-10	146
05-926-11	146
05-926-13	146
05-926-14	146
05-926-15	146

05-926-16	146
05-926-18	146
05-926-20	146
05-926-25	146
05-926-30	146
05-926-35	146
05-927-10	146
05-927-11	146
05-927-13	146
05-927-14	146
05-927-15	146
05-927-16	146
05-927-18	146
05-927-20	146
05-927-25	146
05-927-30	146
05-927-35	146
05-928-15	147
05-929-15	147
05-930-12	147
05-930-13	147
05-930-14	147
05-930-15	147
05-930-18	147
05-930-21	147
05-930-25	147
05-930-31	147
05-931-15	147
05-932-15	147
05-933-15	147
05-933-20	147
05-933-25	147
05-934-15	147
05-934-20	147
05-934-25	147
05-935-20	148
05-936-20	148
05-937-18	148
05-937-21	148
05-937-25	148
05-938-18	148
05-938-21	148
05-938-25	148
05-939-12	148
05-940-01	148
05-940-02	148
05-940-12	148
05-940-15	148
05-941-12	148
05-942-12	149
05-942-15	149
05-943-12	149
05-943-15	149
05-944-12	149
05-945-12	149
05-150-15	149
05-151-12	149
05-152-12	149
05-153-12	149
05-154-12	149
04-248-15	149

05-946-15	149
05-947-12	149
05-947-15	149
05-948-14	149
05-949-12	149
05-949-15	149
04-123-13	149
04-123-15	149
04-123-18	149
04-123-20	149
05-950-17	150
05-950-17B	150
05-951-17	150
05-952-18	150
05-952-18B	150
05-953-18	150
05-954-14	150
05-954-20	150
05-955-14	150
05-955-20	150
05-966-15	150
05-956-20	150
05-956-25	150
05-957-19	150
05-958-15	150
05-958-20	150
05-958-25	150
05-959-18	151
05-959-20	151
05-959-25	151
05-960-17	151
05-961-17	151
05-962-17	151
05-963-17	151
05-964-17	151
05-965-18	151
05-966-17	151
05-967-17	151
05-968-15	152
05-968-18	152
05-969-11	152
05-969-12	152
05-969-13	152
05-970-11	152
05-970-12	152
05-970-13	152
05-971-14	152
05-972-16	152
05-973-16	152
05-973-20	152
05-974-14	152
05-975-01	152
05-975-10	152
05-976-10	153
05-976-11	153
05-976-12	153
05-976-14	153
05-976-15	153
05-976-16	153
05-977-10	153
05-977-11	153

05-977-12	153
05-977-14	153
05-977-15	153
05-977-16	153
05-978-10	153
05-978-11	153
05-978-12	153
05-978-14	153
05-978-15	153
05-978-16	153
05-979-10	153
05-979-11	153
05-979-12	153
05-979-14	153
05-979-15	153
05-979-16	153
05-980-10	153
05-980-11	153
05-980-12	153
05-980-14	153
05-980-15	153
05-980-16	153
05-981-10	153
05-981-11	153
05-981-12	153
05-981-14	153
05-981-15	153
05-981-16	153
05-982-07	153
05-982-01	153
05-983-07	153
05-983-01	153
05-984-07	153
05-984-01	153
05-985-07	153
05-985-01	153
05-986-09	154
05-986-10	154
05-986-11	154
05-986-12	154
05-987-09	154
05-987-10	154
05-987-11	154
05-987-12	154
05-988-09	154
05-988-10	154
05-988-11	154
05-988-12	154
05-989-09	154
05-989-10	154
05-989-11	154
05-989-12	154
05-990-14	155
05-990-16	155
05-990-20	155
05-991-15	155
05-991-20	155
05-991-25	155
05-991-30	155
05-992-15	155
05-992-20	155

05-992-25	155
05-992-30	155
05-993-23	155
05-994-18	155
05-995-23	155
05-996-35	155
05-997-20	155
05-998-20	155
05-999-20	155
05-100-12	156
05-100-14	156
05-100-16	156
05-100-20	156
05-100-24	156
05-100-30	156
05-100-35	156
05-101-12	156
05-101-14	156
05-101-16	156
05-101-20	156
05-101-24	156
05-101-30	156
05-101-35	156
05-102-12	156
05-102-14	156
05-102-16	156
05-102-20	156
05-102-24	156
05-102-30	156
05-102-35	156
05-103-12	156
05-103-14	156
05-103-16	156
05-103-20	156
05-103-24	156
05-103-30	156
05-103-35	156
05-104-14	156
05-104-16	156
05-104-20	156
05-104-24	156
05-104-30	156
05-105-14	156
05-105-16	156
05-105-20	156
05-105-24	156
05-105-30	156
05-106-16	156
05-106-20	156
05-106-24	156
05-107-16	156
05-107-20	156
05-107-24	156
05-108-16	156
05-108-20	156
05-108-24	156
05-109-16	156
05-109-20	156
05-109-24	156
05-110-16	156
05-110-20	156

05-110-24	156
05-111-14T	157
05-111-20T	157
05-111-25T	157
05-111-30T	157
05-112-15T	157
05-113-18T	157
05-113-21T	157
05-113-25T	157
05-114-12T	157
05-114-15T	157
05-115-15T	157
05-115-23T	157
05-116-17T	157
05-117-18T	157
05-118-12T	158
05-118-15T	158
05-119-12T	158
05-119-15T	158
05-120-12T	158
05-120-15T	158
05-121-15T	158
05-122-14T	158
05-123-16T	158
05-124-18T	158
05-125-20T	158
05-126-25T	158
05-127-30T	158
05-128-15T	158
05-128-19T	158
05-128-24T	158
05-129-15T	158
05-129-19T	158
05-129-24T	158
05-130-07	159
05-130-09	159
05-130-11	159
05-131-10	159
05-132-10	159
05-133-10	159
05-134-10	159
05-135-08	159
05-130-01	159
05-136-08	159
05-136-10	159
05-136-12	159
05-137-09	160
05-138-09	160
05-139-09	160
05-140-08	160
05-141-09	160
05-142-09	160
05-143-10	160
05-175-12	161
05-176-11	161
05-177-11	161
05-178-11	161
05-179-11	161
05-180-11	161
05-184-09	161
05-168-15	162

05-168-18	162
05-169-18	162
05-170-15	162
05-171-15	162
05-172-14	162
05-172-18	162
05-173-17	162
05-174-17	162
05-156-18	163
05-156-21	163
05-157-17	163
05-157-21	163
05-190-22	164
05-191-22	164
05-192-22	164
05-193-22	164
05-194-22	164
05-195-22	164
05-271-22	164
05-271-24	164
05-272-22	164
05-272-24	164
05-273-22	164
05-273-24	164
05-274-22	164
05-275-22	164
05-276-22	164
05-277-22	164

## 06

Artery - Haemostatic Forceps  
Arterie - Blutstillende Pinzette  
Arteria - Pinzas hemostáticas  
Artère - Pince hémostatique  
Arteria - Forcipe emostatico

06-211-10	166
06-212-10	166
06-213-08	166
06-214-12	166
06-214-14	166
06-215-12	166
06-215-14	166
06-216-12	166
06-216-14	166
06-217-12	166
06-217-14	166
06-215-01	166
06-215-00	166
06-218-12	166
06-219-12	166
06-220-12	166
06-221-12	166
06-222-10	166
06-222-12	166
06-223-10	166
06-223-12	166
06-224-10	166
06-224-12	166
06-225-10	166
06-225-12	166

06-226-14	167
06-227-14	167
06-228-14	167
06-229-14	167
06-230-12	167
06-231-13	167
06-232-15	167
06-233-15	167
06-234-15	167
06-235-15	167
06-236-15	167
06-237-15	168
06-238-15	168
06-239-14	168
06-240-14	168
06-241-16	168
06-242-16	168
06-245-14	168
06-246-14	168
06-247-14	168
06-248-14	168
06-249-16	168
06-250-16	168
06-251-16	168
06-252-16	168
06-257-01	168
06-257-02	168
06-257-03	168
06-257-04	168
06-257-05	168
06-257-06	168
06-257-08	168
06-257-09	168
06-257-10	168
06-257-11	168
06-257-12	168
06-257-13	168
06-255-14	169
06-255-16	169
06-256-14	169
06-256-16	169
06-257-13	169
06-257-14	169
06-257-16	169
06-258-13	169
06-258-14	169
06-258-16	169
06-259-12	169
06-260-15	169
06-261-15	169
06-262-13	169
06-262-14	169
06-262-16	169
06-263-13	169
06-263-14	169
06-263-16	169
06-264-14	170
06-265-16	170
06-266-18	170
06-267-14	170
06-268-16	170

06-269-18	170
06-270-14	170
06-271-16	170
06-272-18	170
06-273-14	170
06-274-16	170
06-275-18	170
06-276-14	171
06-277-16	171
06-278-18	171
06-279-20	171
06-280-22	171
06-281-24	171
06-282-26	171
06-283-30	171
06-284-35	171
06-285-14	172
06-286-16	172
06-287-18	172
06-288-20	172
06-289-22	172
06-290-24	172
06-291-26	172
06-292-30	172
06-293-35	172
06-294-14	173
06-295-16	173
06-296-18	173
06-297-20	173
06-298-22	173
06-299-24	173
06-300-26	173
06-301-30	173
06-302-35	173
06-303-14	174
06-304-16	174
06-305-18	174
06-306-20	174
06-307-22	174
06-308-24	174
06-309-26	174
06-310-30	174
06-311-35	174
06-312-19	175
06-313-19	175
06-314-15	175
06-314-18	175
06-315-15	175
06-315-18	175
06-316-14	175
06-316-22	175
06-317-16	175
06-317-20	175
06-318-16	175
06-318-20	175
06-319-13	176
06-320-13	176
06-321-15	176
06-331-20	176
06-322-14	176
06-323-15	176

06-324-14	176
06-337-20	177
06-337-26	177
06-338-20	177
06-338-26	177
06-339-20	177
06-339-26	177
06-340-20	177
06-340-26	177
06-341-18	177
06-342-18	177
06-343-18	177
06-344-18	177
06-345-20	178
06-346-20	178
06-347-20	178
06-348-14	178
06-349-18	178
06-350-13	178
06-351-14	178
06-352-18	178
06-353-19	179
06-354-22	179
06-355-24	179
06-356-19	179
06-357-22	179
06-358-24	179
06-359-18	179
06-360-21	179
06-361-23	179
06-362-19	180
06-363-19	180
06-364-21	180
06-364-26	180
06-365-21	180
06-365-26	180
06-366-21	180
60-366-26	180
06-367-21	180
06-367-26	180
06-368-23	181
06-369-23	181
06-370-23	181
06-371-23	181
06-372-23	181
06-373-18	181
06-373-27	181
06-374-28	181
06-375-21	182
06-375-27	182
06-376-21	182
06-376-27	182
06-377-21	182
06-377-27	182
06-378-21	182
06-378-27	182
06-379-21	182
06-379-27	182
06-380-21	182
06-380-27	182
06-381-21	182

06-381-27	182
06-382-21	183
06-383-21	183
06-384-22	183
06-385-23	183
06-386-22	183
06-387-29	183
06-388-29	183
06-389-30	183
06-390-18	184
06-391-20	184
06-392-21	184
06-393-21	184
06-394-21	184
06-395-28	184
06-396-28	184
06-397-13	185
06-398-16	185
06-399-18	185
06-400-20	185
06-401-23	185
06-402-25	185
06-403-28	185
06-404-35	185
06-405-18	185
06-406-22	185
06-407-25	185
06-408-28	185
06-408-29	186
06-409-29A	186
06-410-42	186
06-411-22	186
06-412-15	186
06-412-19	186
06-413-19	186
06-413-24	186
06-413-26	186
06-414-22	186
06-414-24	186
06-414-35	186
06-415-23	187
06-416-20	187
16-203-12	187
16-204-12	187
16-205-12	187
16-206-14	187
16-207-14	187
16-208-14	187
16-209-12	187
06-417-19	187
06-418-21	187
06-418-24	187
06-419-18	188
06-419-24	188
06-420-24	188
06-420-35	188
06-421-24	188
06-421-35	188
06-422-18	188
06-423-19	188
06-424-19	188

06-425-18	189
06-426-19	189
06-426-23	189
06-427-22	189
06-428-24	189
06-429-22	189
06-430-25	189
06-431-28	189
06-432-20	190
06-433-22	190
06-434-24	190
06-435-23	190
06-436-23	190
06-437-22	190
06-438-23	190
06-439-22	190
06-440-23	190
06-441-23	191
06-442-23	191
06-443-23	191
06-444-20	192
06-445-22	192
06-445-23	192
06-445-35	192
06-446-21	192
06-447-21	192
06-448-23	192
06-449-24	192
06-450-14	193
06-451-18	193
06-451-20	193
06-452-20	194
06-452-25	194
01-453-25	194
06-454-21	194
06-455-21	195
06-456-21	195
06-457-21	195
06-458-21	195
06-464-20	196
06-465-20	196
06-466-22	197
06-467-22	197
06-468-22	197
06-469-23	198
06-470-23	198
06-471-24	198
06-472-24	198
06-473-15	199
06-474-26	199
06-475-26	199
06-476-26	199
06-477-26	199
06-478-10	200
06-478-12	200
06-478-14	200
06-478-16	200
06-478-18	200
06-479-09	200
06-479-11	200
06-479-13	200

06-479-15	200
06-480-13	200
06-480-15	200
06-481-11	201
06-482-13	201
06-483-05	201
06-483-09	201
06-484-09	201
06-485-18	202
06-486-10	202
06-486-13	202
06-487-13	202
06-487-15	202
06-487-20	202
06-488-10	203
06-488-13	203
06-489-14	203
06-490-11	203
06-490-14	203
06-491-15	204
06-491-16	204
06-491-19	204
06-491-24	204
06-492-15	204
06-492-16	204
06-492-19	204
06-493-16	204
06-493-18	204
06-494-14	204
06-495-14	204
06-496-18	204

## 07

Cotton Swab Forceps  
 Wattestäbchen Pinzette  
 Pinzas para hisopos de algodón  
 Pincès à coton-tige  
 Pinza per cotton fioc

07-400-20	206
07-401-20	206
07-400-22	206
07-401-22	206
07-400-25	206
07-401-25	206
07-400-27	206
07-401-27	206
07-402-20	206
07-403-20	206
07-402-25	206
07-403-25	206
07-404-22	206
07-405-22	206
07-404-25	206
07-405-25	206
07-404-27	206
07-405-27	206
07-404-35	206
07-405-35	206
06-125-18	207
06-126-25	207



07-406-18	207
07-407-18	207
07-406-25	207
07-407-25	207
07-408-25	207
07-409-25	208
07-410-25	208
07-411-25	208
17-169-24	209
07-412-18	209
07-412-20	209
07-412-25	209
07-412-30	209
07-413-18	209
07-413-20	209
07-413-25	209
07-413-30	209
07-414-18	209
07-414-20	209
07-414-25	209
07-414-30	209
07-415-18	209
07-415-20	209
07-415-25	209
07-415-30	209
07-416-26	210
07-417-26	210
07-418-25	211
07-419-17	211
07-420-17	211
07-419-25	211
07-420-25	211
07-421-13	212
07-422-13	212
07-422-16	212
07-422-18	212
07-423-20	212
07-424-20	212

## 08

Retractors  
Wundhaken  
Separadores  
Ecarteurs  
Divaricatori

08-600-15	214
08-601-15	214
08-602-22	214
08-603-16	214
08-604-17	214
08-605-15	214
08-606-15	214
08-607-15	214
08-608-16	214
08-609-16	214
08-610-18	215
08-611-18	215
08-612-16	215
08-613-16	215
08-614-16	215

08-615-16	215
08-616-20	215
08-617-16	215
08-618-15	215
08-619-15	215
08-620-15	215
08-621-16	215
08-622-15	216
08-623-15	216
08-624-19	216
08-625-10	216
08-626-12	216
08-627-15	216
08-628-17	216
08-629-17	217
08-630-18	217
08-631-18	217
08-632-13	217
08-633-11	217
08-634-21	217
08-635-22	218
08-636-22	218
08-637-22	218
08-638-22	218
08-639-22	218
08-640-16	218
08-641-16	218
08-642-16	218
08-643-16	218
08-644-16	218
08-645-16	218
08-646-16	218
08-647-16	218
08-648-16A	219
08-648-16	219
08-649-16	219
08-650-16	219
08-651-16A	219
08-651-16	219
08-652-16	219
08-653-16	219
08-654-16	219
08-655-16	219
08-656-16	219
08-657-16	219
08-658-16	219
08-659-16	219
08-660-16	219
08-661-16	220
08-662-16	220
08-663-16	220
08-664-16	220
08-665-22	220
08-666-22	220
08-667-22	220
08-668-22	220
08-669-22	220
08-670-22	220
08-671-22	220
08-672-22	220
08-673-22	220

08-674-22	220
08-675-22	220
08-676-22	220
08-677-22	220
08-678-22	220
08-679-22	220
08-680-22	220
08-681-22	220
08-682-22	220
08-683-22	220
08-684-22	220
08-685-22	220
08-686-21	221
08-687-21	221
08-688-21	221
08-689-21	221
08-690-21	221
08-691-21	221
08-692-21	221
08-693-21	221
08-694-21	221
08-695-21	221
08-696-21	221
08-697-21	221
08-698-21	221
08-699-21	221
08-700-21	221
08-701-21	222
08-702-21	222
08-703-16	222
08-704-16	222
08-705-15	222
08-706-19	222
08-707-19	222
08-708-15	222
08-709-15	222
08-710-14	223
08-711-15	223
08-712-11	223
08-713-21	223
08-714-22	223
08-715-23	223
08-716-18	224
08-717-18	224
08-718-18	224
08-719-18	224
08-720-18	224
07-721-18	224
08-722-23	224
08-723-23	224
08-724-21	224
08-725-25	225
08-726-25	225
08-727-25	225
08-728-25	225
08-729-22	225
08-730-22	225
08-731-22	225
08-732-22	225
08-733-22	225
08-734-21	226

08-735-21	226
08-736-21	226
08-737-21	226
08-738-21	226
08-739-21	226
08-740-21	226
08-741-21	226
08-742-21	226
08-743-21	226
08-744-21	226
08-745-21	226
08-746-21	226
08-747-21	226
08-748-20	227
08-749-20	227
08-750-20	227
08-751-20	227
08-752-20	227
08-753-20	227
08-748-24	227
08-749-24	227
08-750-24	227
08-751-24	227
08-752-24	227
08-753-24	227
08-754-22	227
08-755-22	227
08-756-22	227
08-757-22	228
08-758-22	228
08-759-15	228
08-760-16	228
08-761-16	228
08-762-22	229
08-763-22	229
08-764-21	229
08-765-21	229
08-766-21	229
08-767-21	229
08-768-22	230
08-769-22	230
08-770-22	230
08-771-19	230
08-772-19	230
08-273-19	230
08-774-22	230
08-775-22	230
08-776-22	230
08-777-23	231
08-778-22	231
08-779-22	231
08-780-22	231
08-781-22	231
08-782-24	231
08-783-24	231
08-784-24	231
08-785-00	232
08-785-28	232
08-786-26	232
08-787-24	232
08-788-26	232

08-789-26	233	08-847-24	245	08-893-07	257	08-924-13	262
08-790-26	233	08-848-24	245	08-893-10	257	08-924-16	262
08-791-26	233	08-849-24	245	08-894-07	257	08-924-20	262
08-792-26	233	08-850-29	245	08-894-10	257	08-924-26	262
08-793-26	233	08-851-32	245	08-895-10	257	08-925-13	262
08-794-26	233	08-852-33	245	08-896-10	257	08-925-16	262
08-795-20	234	08-853-20	246	08-897-07	257	08-925-20	262
08-796-22	234	08-854-28	246	08-898-10	257	08-925-26	262
08-797-24	234	08-855-21	246	08-899-10	257	08-926-32	262
08-798-23	234	08-856-24	246	08-898-11	257	08-927-31	263
08-798-24	234	08-857-24	246	08-899-11	257	08-928-31	263
08-798-25	234	08-858-24	246	08-900-14	258	08-929-31	263
08-798-25B	234	10-227-13	247	08-901-14	258	08-930-24	263
08-799-25	234	10-227-15	247	08-902-10	258	08-930-40	263
08-800-26	234	10-227-16	247	08-903-10	258	08-931-24	263
08-801-28	235	10-221-01	247	08-904-13	258	08-931-40	263
08-802-28	235	10-221-02	247	08-905-13	258	08-932-31	264
08-803-32	235	10-221-03	247	08-906-13	258	08-933-31	264
08-804-32	235	08-859-31	248	08-907-11	259	08-934-31	264
08-805-26	236	08-860-31	248	08-907-13	259	08-935-31	264
08-806-26	236	08-861-31	248	08-908-11	259	08-936-09	265
08-807-26	236	08-862-31	248	08-908-13	259	08-936-11	265
08-808-26	237	08-863-31	248	08-909-15	259	08-936-13	265
08-809-16	237	08-864-18	249	08-910-10	259	08-936-15	265
08-810-16	237	08-865-21	249	08-911-10	259	08-936-18	265
08-811-27	238	08-866-23	249	08-912-10	259	08-937-09	265
08-812-27	238	08-867-30	250	08-913-10	259	08-937-11	265
08-813-25	238	08-868-33	250	08-914-10	259	08-937-13	265
08-814-26	238	08-869-36	250	08-915-10	259	08-937-15	265
08-815-27	238	08-870-30	251	08-910-13	259	08-937-18	265
08-816-29	238	08-871-30	251	08-911-13	259	08-938-18	265
08-817-25	239	08-872-30	251	08-912-13	259	08-939-18	265
08-818-25	239	08-873-00	252	08-913-13	259	08-940-18	265
08-819-27	239	08-873-14	252	08-914-13	259	08-941-18	266
08-820-25	239	08-874-15	252	08-915-13	259	08-941-20	266
08-821-25	239	08-875-17	252	08-910-16	259	08-941-23	266
08-822-25	239	08-876-00	252	08-911-16	259	08-942-20	266
08-823-25	240	08-876-13	252	08-912-16	259	08-943-00	267
08-824-22	240	08-877-13	252	08-913-16	259	08-944-75	267
08-825-25	240	08-878-00	253	08-914-16	259	08-945-75	267
08-826-25	240	08-878-18	253	08-915-16	259	08-946-50	267
08-827-25	240	08-879-18	253	08-910-20	259	08-947-10	267
08-828-23	241	08-880-14	253	08-911-20	259	08-948-32	268
08-829-25	241	08-881-13	253	08-912-20	259	08-948-54	268
08-830-25	241	08-882-00	254	08-913-20	259	08-948-60	268
08-831-27	242	08-882-15	254	08-914-20	259	08-949-19	268
08-832-27	242	08-883-15	254	08-915-20	259	08-950-19	268
08-833-27	242	08-884-00	254	08-910-26	259	08-951-18	269
08-834-24	242	08-884-21	254	08-911-26	259	08-952-18	269
08-835-24	242	08-885-21	254	08-912-26	259	08-993-00	270
08-836-24	242	08-886-00	255	08-913-26	259	08-993-16	270
08-837-25	243	08-886-20	255	08-914-26	259	08-995-19	270
08-838-25	243	08-887-20	255	08-915-26	259	08-996-25	270
08-839-25	243	08-888-00	256	08-916-13	260	08-997-32	270
08-840-25	243	08-888-12	256	08-917-13	260	08-994-00	270
08-841-25	243	08-889-12	256	08-918-11	260	08-994-16	270
08-842-25	243	08-890-00	256	08-919-11	260	08-994-19	270
08-843-24	244	08-890-15	256	08-920-22	261	08-994-25	270
08-844-24	245	08-891-15	256	08-921-21	261	08-994-32	270
08-845-24	245	08-892-07	257	08-922-19	261	08-998-00	271
08-846-24	245	08-892-10	257	08-923-19	261	08-998-18	271

08-998-01	271
08-998-02	271
08-999-22	271
08-101-22	271
08-102-22	271
08-103-22	271
08-104-26	272
08-105-26	272
08-106-12	273
08-107-18	273
08-108-16	274
08-108-00	274
08-108-01	274
08-108-02	274
08-109-20	274
08-109-00	274
08-109-01	274
08-109-02	274
08-110-27	274
08-110-00	274
08-110-01	274
08-110-02	274
08-111-18	275
08-111-00	275
08-111-01	275
08-111-02	275
08-112-18	275
08-112-00	275
08-112-01	275
08-112-02	275
08-113-45	275
08-113-70	275
08-113-80	275
08-114-28	276
08-114-00	276
08-114-01	276
08-114-02	276
08-115-45	276
08-115-00	276
08-115-01	276
08-115-02	276
08-115-30	276
08-116-00	276
08-116-01	276
08-116-02	276
08-130-00	277
08-156-01	277
08-157-02	277
08-158-03	277
08-159-10	277
08-177-00	278
08-117-24	278
80-118-05	278
08-119-08	278
08-120-05	278
08-121-03	278
08-122-00	278
08-122-24	278
08-123-04	278
08-124-50	278
08-130-00	279

08-130-06	279
08-131-04	279
08-132-04	279
08-134-05	279
08-135-06	279
08-130-01	279
08-130-06	279
08-130-04	279
08-134-05	279
08-135-06	279
08-125-30	280
08-131-04	280
08-132-04	280
08-133-04	280
08-134-05	280
08-135-06	280
08-136-08	280
08-137-05	280
08-138-03	280
08-139-33	281
08-140-33	281
08-141-33	281
08-142-20	281
08-143-20	281
08-144-25	281
80-145-20	281
08-146-20	281
08-147-20	281
08-148-20	281
08-149-20	281
80-150-20	281
08-151-20	282
08-152-28	282
08-153-30	282
08-154-28	282
13-873-15	283
13-873-00	283
13-873-15	283
13-874-17	283
13-874-00	283
13-874-17	283
13-875-15	283
13-875-00	283
13-876-40	283
13-876-45	283
13-876-50	283
13-876-55	283
13-876-60	283
13-877-40	283
13-877-45	283
13-877-50	283
13-877-55	283
13-877-60	283
08-166-16	284
08-167-16	284
08-167-25	284
08-167-27	284
08-168-16	284
08-171-12	285
08-171-08	285
08-172-65	285

08-172-75	285
08-172-85	285
08-172-10	285
08-217-07	286
08-218-08	286
08-219-10	286

## 09

Suture	
Naht	
Sutura	
Suture	
Sutura	
09-800-15	288
09-801-15	288
09-801-18	288
09-802-14	288
09-803-13	288
09-803-18	288
09-804-12	288
09-805-12	288
09-806-12	288
09-807-13	289
09-808-13	289
09-809-13	289
09-810-12	289
09-811-20	289
09-812-14	290
09-813-16	290
09-814-18	290
09-815-20	290
09-816-24	290
09-817-26	290
09-818-30	290
09-819-14	290
09-820-16	290
09-821-18	290
09-822-20	290
09-823-24	290
09-824-26	290
09-825-16	290
09-825-18	290
09-825-20	290
09-826-18	290
09-826-26	290
09-827-23	290
09-828-27	291
09-829-27	291
09-830-23	291
09-831-27	292
09-832-20	292
09-832-24	292
09-833-20	292
09-833-20T	292
09-834-14	292
09-834-17	292
09-834-19	292
09-835-14	292
09-836-16	292
09-837-14	293

09-837-17	293
09-837-20	293
09-837-24	293
09-838-14	293
09-838-17	293
09-838-20	293
09-838-24	293
09-839-14	293
09-839-17	293
09-839-20	293
09-839-24	293
09-840-14	293
09-840-17	293
09-840-20	293
09-841-17	293
09-841-20	293
09-842-18	293
09-843-17	293
09-843-20	293
07-117-13	293
07-117-18	293
09-840-14	293
09-840-17	293
09-841-17	293
09-840-20	293
09-841-20	293
09-842-18	293
09-843-17	293
09-843-20	293
09-844-14	294
09-844-15	294
09-844-18	294
09-844-21	294
09-845-14	294
09-845-15	294
09-845-18	294
09-845-21	294
09-846-14	294
09-846-15	294
09-846-18	294
09-846-21	294
09-847-14	294
09-847-15	294
09-847-18	294
09-847-21	294
09-848-12	294
09-849-14	294
09-850-16	294
09-851-16	294
09-254-15	294
09-255-15	294
09-256-15	294
09-257-15	294
09-852-14T	295
09-853-15T	295
09-854-15T	295
09-855-18T	295
09-856-20T	295
09-857-20T	295
09-858-20T	295
09-859-12T	295

09-860-13T	295	09-915-20T	302	09-943-15	306	09-954-14T	309
09-861-13T	295	09-915-23T	302	09-943-18	306	09-955-000	310
09-862-13T	295	09-916-18T	302	09-943-21	306	09-956-00	310
09-863-13T	296	09-917-18T	303	09-944-18	306	09-957-0	310
09-864-13T	296	09-918-20T	303	09-945-18	306	09-958-1	310
09-864-14T	296	09-919-26T	303	09-946-18	306	09-959-2	310
09-864-15T	296	09-920-18T	303	09-947-18	306	09-960-3	310
09-865-16T	296	09-921-20T	303	07-333-14	307	09-961-4	310
09-866-18T	296	09-922-23T	303	07-333-18	307	09-962-5	310
09-867-20T	296	09-923-26T	303	07-333-21	307	09-963-6	310
09-868-24T	296	09-924-15T	303	07-333-23	307	09-964-7	310
09-869-26T	296	09-924-18T	303	07-334-14	307	09-965-8	310
09-870-30T	296	09-924-20T	303	07-334-18	307	09-966-9	310
09-871-13T	296	09-925-15T	303	07-334-21	307	09-967-10	310
09-872-13T	296	09-925-18T	303	07-334-23	307	09-968-11	310
09-873-14T	296	09-925-20T	303	07-335-14	307	09-969-12	310
09-874-17T	296	09-926-14T	304	07-335-18	307	09-970-13	310
09-875-20T	296	09-927-18T	304	07-335-21	307	09-971-14	310
09-876-20T	297	09-928-20T	304	07-335-23	307	09-972-15	310
09-877-14T	297	09-929-23T	304	07-336-14	307	09-973-16	310
09-877-16T	297	09-930-13T	304	07-336-18	307	09-974-000	311
09-878-12T	297	09-930-15T	304	07-336-21	307	09-975-00	311
09-879-12T	297	09-930-18T	304	07-336-23	307	09-976-0	311
09-880-12T	297	09-930-20T	304	07-337-15	307	09-977-01	311
09-881-12T	297	09-930-23T	304	07-337-18	307	09-978-02	311
09-882-05T	297	09-930-26T	304	07-338-18	307	09-979-02	311
09-883-17T	297	09-931-13T	304	07-339-21	307	09-980-04	311
09-884-19T	297	09-931-15T	304	07-339-23	307	09-981-05	311
09-885-23T	298	09-931-18T	304	07-340-23	307	09-982-06	311
09-886-16T	298	09-931-20T	304	07-341-15	307	09-983-07	311
09-886-18T	298	09-931-23T	304	07-341-18	307	09-984-08	311
09-886-20T	298	09-931-26T	304	07-341-21	307	09-985-09	311
09-887-20T	298	09-932-16T	304	07-341-23	307	09-986-10	311
09-888-24T	298	09-932-18T	304	07-342-15	307	09-987-11	311
09-889-26T	298	09-932-20T	304	07-342-18	307	09-988-12	311
09-890-30T	298	09-932-23T	304	07-343-18	307	09-989-13	311
09-891-27T	299	09-932-25T	304	07-344-21	307	09-990-14	311
09-892-27T	299	09-933-13	305	07-344-23	307	09-991-15	311
09-893-27T	299	09-934-15	305	07-345-23	307	09-992-16	311
09-894-14T	300	09-935-17	305	07-346-15	307	09-993-000	312
09-895-17T	300	09-936-18	305	07-346-18	307	09-994-00	312
09-896-20T	300	09-937-20	305	07-346-21	307	09-995-0	312
09-897-24T	300	09-938-23	305	07-346-23	307	09-996-01	312
09-898-17T	300	09-939-13	305	07-360-14	308	09-997-02	312
09-899-20T	300	09-939-15	305	07-360-18	308	09-998-03	312
09-900-14T	300	09-939-18	305	07-360-21	308	09-999-04	312
09-901-17T	300	09-939-20	305	07-361-14	308	09-100-05	312
09-902-20T	300	09-939-23	305	07-361-18	308	09-101-06	312
09-903-24T	300	09-940-14	306	07-361-21	308	09-102-07	312
09-904-17T	301	09-940-15	306	07-362-14	308	09-103-08	312
09-905-20T	301	09-940-18	306	07-362-18	308	09-104-09	312
09-906-17T	301	09-940-21	306	07-362-21	308	09-105-000	312
09-907-20T	301	09-941-14	306	07-363-14	308	09-106-00	312
09-908-20T	301	09-941-15	306	07-363-18	308	09-107-0	312
09-909-25T	301	09-941-18	306	07-363-21	308	09-108-01	312
09-910-20T	301	09-941-21	306	09-948-13T	308	09-109-02	312
09-911-20T	302	09-942-14	306	09-949-13T	308	09-110-03	312
09-912-23T	302	09-942-15	306	09-950-13T	309	09-111-04	312
09-913-16T	302	09-942-18	306	09-951-13T	309	09-112-05	312
09-914-16T	302	09-942-21	306	09-952-13T	309	09-113-06	312
09-915-18T	302	09-943-14	306	09-953-12T	309	09-114-01	312

09-115-02	312
01-116-03	312
09-117-04	312
09-118-05	312
09-119-06	312
09-120-01	312
09-121-02	312
09-122-03	312
09-123-04	312
09-124-05	312
09-125-06	312
09-126-00	313
09-127-0	313
09-128-01	313
09-129-02	313
09-130-03	313
09-131-04	313
09-132-05	313
09-133-06	313
09-134-07	313
09-135-08	313
09-136-00	313
09-137-0	313
09-138-01	313
09-139-02	313
09-140-03	313
09-141-04	313
09-142-05	313
09-143-06	313
09-144-07	313
09-145-08	313
09-146-00	313
09-147-0	313
09-148-01	313
09-149-02	313
09-150-03	313
09-151-04	313
09-152-05	313
09-153-06	313
09-154-07	313
09-155-08	313
09-156-0	314
09-157-01	314
09-158-02	314
09-159-03	314
09-160-04	314
09-161-05	314
09-162-0	314
09-163-01	314
09-164-02	314
09-156-03	314
09-157-04	314
09-158-05	314
09-159-00	314
09-160-0	314
09-161-01	314
09-162-02	314
09-163-03	314
09-164-00	314
09-165-0	314
09-166-01	314

09-167-02	314
09-168-03	314
09-169-00	314
09-170-0	314
09-171-01	314
09-172-02	314
09-173-03	314
09-174-15	315
09-174-19	315
09-174-22	315
09-175-15	315
09-175-19	315
09-175-22	315
09-176-15	315
09-176-19	315
09-176-22	315
09-177-15	315
09-177-19	315
09-176-22	315
09-178-25	315
09-179-25	315
09-180-25	315
09-181-25	315
09-182-20	316
09-183-19	316
09-184-13	316
09-185-13	316
09-186-20	317
09-186-21	317
09-186-27	317
09-187-20	317
09-187-21	317
09-187-27	317
09-188-20	317
09-188-21	317
09-188-27	317
09-189-20	317
09-189-21	317
09-189-27	317
09-190-26	318
09-191-26	318
09-192-26	318
09-193-26	318
09-194-21	318
09-195-23	318
09-196-23	318
09-197-21	319
09-198-21	319
09-199-22	319
09-200-22	319
09-201-17	320
09-202-17	320
09-203-17	320
09-204-17	320
09-205-17	320
09-206-17	320
09-207-17	320
09-208-17	320
09-209-17	320
09-210-24	320
09-211-24	320

09-212-24	320
09-213-28	321
09-214-25	321
09-215-30	321
09-216-30	321
09-217-30	321
09-218-30	321
09-219-19	322
09-220-19	322
09-221-20	322
09-222-18	322
09-222-27	322
09-223-27	322
09-224-19	322
09-225-19	322
09-226-22	323
09-227-22	323
09-228-23	323
09-229-21	323
09-230-23	323
09-231-18	324
09-232-12	324
09-233-12	324
09-234-12	324
09-235-12	324
09-236-13	324
09-237-14	324
09-238-12	325
09-239-12	325
09-240-12	325
09-241-12	325
09-242-12	325
09-243-12	325
09-244-12	325
09-245-12	325
09-246-12	325
09-417-18	326
09-418-18	326
09-421-18	326
09-422-18	326
09-423-18	326
09-424-18	326
09-419-18	326
09-420-18	326
09-425-09	327
09-426-08	327
09-427-10	327
09-428-18	327
09-429-18	327
09-430-18	327
09-431-18	328
09-432-18	328
09-433-18	328
09-434-18	328
09-435-18	328
09-436-18	328
09-437-18	328
09-438-18	328
09-439-18	328
09-440-19	329
09-441-19	329

09-442-19	329
09-443-19	329
09-444-19	329
09-445-19	329
09-446-19	329
09-447-19	329
09-448-24	330
09-449-24	330
09-450-24	330
09-451-24	330
09-452-24	330
09-453-24	330
09-454-24	330
09-455-24	330
09-456-24	330
09-457-24	330
09-458-24	330
09-459-24	330
09-461-18	330
09-462-12	331
09-463-12	331
09-464-12	331
09-465-16	331
09-466-18	331
09-467-18	331
09-468-18	331
09-469-00	332
09-470-00	332
09-471-19	333
09-472-19	333
09-473-19	333
09-474-19	333
09-475-19	333
09-476-19	333
09-477-19	333
09-478-19	333
09-479-19	333
09-480-19	333
09-481-19	333
09-482-19A	333
09-482-19B	333
09-483-19	333
09-484-19	333
09-485-19	334
09-486-19	334
09-487-19	334
09-488-19	334
09-489-19	335
09-490-19	335
09-491-19	335
09-492-23	335
09-493-23	335
09-494-23	335
09-495-23	335
09-497-24	336
09-498-24	336
09-499-24	336
09-500-24	336
09-501-24	336
09-502-22	336
09-503-22	336

09-504-22	336
09-505-24	336
09-506-25	337
09-507-25	337
09-508-25	337
09-509-25	337
09-510-25	337
09-511-25	337
09-512-25	337
09-513-24	338
09-514-24	338
09-515-24	338
09-516-24	338
09-517-24	338
09-518-24	338
09-519-24	338
09-520-24	338
09-521-24	338
09-522-24	338
09-523-24	338
09-524-24	338
09-525-24	338
09-526-24	338
09-527-24	338
09-528-24	338
09-529-24	338
09-530-24	338
09-531-24	338
09-532-24	338
09-533-24	338
09-534-24	338
09-535-24	338
09-536-24	338
09-537-24	338
09-538-24	338
09-539-24	339
09-540-24	339
09-541-24	339
09-542-24	339
09-543-23	339
09-544-24	339
09-545-24	339
09-546-24	339
09-547-24	339
09-548-24	339
09-549-24	339
09-550-24	339
09-551-24	339
09-552-24	339
09-553-24	339
09-554-24	339
09-555-24	339
09-556-23	339
09-557-24	339
09-558-24	339
09-559-24	339
09-560-24	339
09-561-24	339
09-562-24	340
09-563-24	340
09-564-24	340

09-565-24	340
09-566-24	340
09-567-24	340
09-568-24	340
09-569-01	341
09-569-02	341
09-569-03	341
09-569-04	341
09-569-05	341
09-569-06	341
09-569-07	341
09-569-08	341
09-569-09	341
09-569-10	341
09-569-11	341
09-569-12	341
09-569-13	341
09-569-14	341
09-569-15	341
09-569-16	341
09-569-17	341
09-569-18	341
09-569-19	341
09-569-20	341
09-569-21	341
09-569-22	341
09-569-23	341
09-569-24	341
09-570-24	341
09-571-00	342
13-144-20	342
13-967-18	342
13-213-18	342
13-213-20	342
13-328-20	342
07-360-18	342
21-516-05	342
21-628-01	342
21-609-05	342
09-572-00	343
13-995-14	343
13-996-14	343
13-181-15	343
13-299-05	343
13-300-05	343
21-516-05	343
21-628-01	343
21-609-05	343
09-573-00	344
13-991-18	344
13-992-18	344
13-181-18	344
13-179-18	344
13-182-18	344
13-299-06	344
13-300-06	344
21-516-05	344
21-628-01	344
21-609-05	344
09-577-26	345
09-577-26T	345

09-578-26	345
09-578-26T	345
09-579-18	346
09-579-18T	346
09-580-18	346
09-580-18T	346
09-581-26	347
09-581-26T	347
09-582-26	347
09-582-26T	347
09-583-26	347
09-583-26T	347
09-584-21	347
09-584-21T	347
09-585-26	348
09-586-26	348
09-587-26	348
09-589-26	348
09-590-26	348
09-590-26T	348
09-591-26	348
09-591-26T	348
09-592-26	348
09-592-26T	348
09-593-26	348
09-593-26T	348
09-594-24	349
09-594-24T	349
09-595-24	349
09-595-24T	349
09-596-24	349
09-596-24T	349
09-597-24	349
09-597-24T	349
09-598-24	349
09-598-24T	349
09-599-24	349
09-599-24T	349
09-600-24	349
09-601-24T	349
09-602-24	349
09-602-24T	349
09-603-24	349
09-603-24T	349
09-604-24	349
09-604-24T	349
09-605-24T	349
09-606-26	350
09-606-26T	350
09-607-26	350
09-607-26T	350
09-608-26	350
09-608-26T	350
09-609-26	350
09-609-26T	350
09-610-26	350
09-610-26T	350
09-611-26	350
09-611-26T	350
09-612-26	350
09-612-26T	350

## 10

Cardiovascular Surgery  
 Herz-Kreislauf-Chirurgie  
 Cirugia Cardiovascular  
 Chirurgie cardiovasculaire  
 Chirurgia cardiovascolare

10-100-50	352
10-101-50	352
10-102-50	352
10-103-50	352
10-104-50	352
10-105-50	352
10-106-50	352
10-107-50	352
10-108-50	352
10-109-12	352
10-110-32	352
10-111-32	352
10-112-00	353
10-113-00	353
10-114-00	353
10-115-00	353
10-116-00	353
10-117-00	353
10-118-00	353
10-119-00	353
10-120-00	353
10-121-00	353
10-122-00	354
10-123-00	354
10-124-00	354
10-125-00	354
10-126-00	354
10-127-00	354
10-128-00	354
10-129-00	354
10-130-00	354
10-131-00	354
10-132-14	355
10-133-14	355
10-134-14	355
10-135-01	356
10-135-02	356
10-136-01	356
10-136-02	356
10-137-01	356
10-137-02	356
10-138-01	356
10-138-02	356
10-139-01	356
10-139-02	356
10-140-01	356
10-140-02	356
10-141-01	356
10-141-02	356
10-142-01	356
10-142-02	356
10-143-01	356
10-143-02	356
10-144-01	356

10-144-02	356	10-191-09	359	10-248-20	364	10-306-23	377
10-145-01	356	10-192-23	359	10-248-24	364	10-307-27	377
10-145-02	356	10-001-19	359	10-249-15	364	10-308-20	377
10-146-01	356	10-002-01	359	10-249-20	364	10-309-21	377
10-146-02	356	10-002-02	359	10-249-24	364	10-310-25	377
10-147-01	356	10-002-03	359	10-250-20	365	10-311-30	377
10-147-02	356	10-003-03	359	10-251-22	365	10-312-17	378
10-148-01	356	10-003-05	359	10-252-20	365	10-313-17	378
10-148-02	356	10-003-06	359	10-253-22	365	10-314-17	378
10-149-01	356	10-004-03	359	10-254-22	365	10-315-17	378
10-149-02	356	10-004-05	359	10-255-21	365	10-316-16	378
10-150-01	356	10-004-06	359	10-256-22	365	10-317-23	379
10-150-02	356	10-193-05	360	10-257-19	366	10-318-21	379
10-151-01	356	10-194-05	360	10-258-23	366	10-319-17	379
10-151-02	356	01-195-05	360	10-259-16	366	10-320-17	379
10-152-01	356	10-196-05	360	10-260-18	367	10-321-18	379
10-152-02	356	10-197-05	360	10-261-19	367	10-322-18	379
10-153-01	356	10-198-05	360	10-262-20	367	10-323-16	380
10-153-02	356	10-199-05	360	10-263-19	367	10-324-18	380
10-154-01	356	10-200-05	360	10-264-20	367	10-325-17	380
10-154-02	356	10-201-05	360	10-265-15	368	10-326-20	380
10-155-01	356	10-202-05	360	10-266-18	368	10-327-14	381
10-155-02	356	10-203-08	360	10-267-15	368	10-328-16	381
10-156-01	356	10-204-09	360	10-268-18	368	10-329-18	381
10-156-02	356	10-205-10	360	10-269-20	368	10-330-16	381
10-157-01	356	10-206-12	360	10-270-26	369	10-331-19	381
10-157-02	356	10-207-07	360	10-271-27	369	10-332-12	382
10-158-01	356	10-208-08	360	10-272-31	369	10-333-11	382
10-158-02	356	10-209-09	360	10-273-33	369	10-334-10	382
10-159-00	357	10-210-11	360	10-274-28	370	10-335-12	382
10-160-00	357	10-211-07	361	10-275-30	370	10-336-13	382
10-161-00	357	10-212-08	361	10-276-26	371	10-337-17	382
10-162-00	357	10-213-10	361	10-277-26	371	10-338-17	382
10-163-00	357	10-214-12	361	10-278-27	372	10-339-16	382
10-164-00	357	10-215-07	361	10-279-24	372	10-340-15	382
10-165-00	357	10-216-08	361	10-280-25	372	10-341-14	382
10-166-00	357	10-217-10	361	10-281-26	372	10-342-20	383
10-167-00	357	01-218-11	361	10-282-24	373	10-343-22	383
10-168-15	357	10-219-05	361	10-283-24	373	10-344-26	383
10-169-18	357	10-220-06	362	10-284-25	373	10-345-20	383
10-170-00	358	10-221-07	362	10-285-26	373	10-346-22	383
10-171-00	358	10-222-09	362	10-286-20	374	10-347-26	383
10-172-00	358	10-223-11	362	10-287-24	374	10-348-17	384
10-173-00	358	10-224-05	362	10-288-25	374	10-349-21	384
10-174-00	358	10-225-06	362	10-289-26	374	10-350-24	384
10-175-00	358	10-226-08	362	10-290-27	374	10-351-22	384
10-176-00	358	10-227-10	362	10-291-23	375	10-352-18	384
10-177-00	358	10-228-05	362	10-292-25	375	10-353-16	384
10-178-03	359	10-229-07	363	10-293-25	375	10-354-17	384
10-179-05	359	10-230-09	363	10-294-20	375	10-355-18	384
10-180-05	359	10-231-10	363	10-295-00	375	10-356-17	384
10-181-06	359	10-232-07	363	10-296-21	376	10-357-11	385
10-182-07	359	10-233-09	363	10-297-23	376	10-358-11	385
10-183-07	359	10-234-11	363	10-298-27	376	10-359-11	385
10-184-09	359	10-246-15	364	10-299-31	376	10-360-11	385
10-185-03	359	10-246-20	364	10-300-21	376	10-361-11	385
10-186-05	359	10-246-24	364	10-301-23	376	10-362-11	385
10-187-05	359	10-247-15	364	10-302-27	376	10-363-11	385
10-188-06	359	10-247-20	364	10-303-31	376	10-364-11	385
10-189-07	359	10-247-24	364	10-304-18	377	10-365-11	385
10-190-07	359	10-248-15	364	10-305-19	377	10-366-13	385

10-367-13	385
10-368-11	385
10-369-12	385
10-370-12	385
10-371-12	385
10-372-15	385
10-373-11	386
10-374-11	386
10-375-11	386
10-376-11	386
10-377-11	386
10-378-11	386
10-379-11	386
10-380-11	386
10-381-11	386
10-382-11	386
10-383-11	386
10-384-11	386
10-385-11	386
10-386-11	386
10-387-11	386
10-388-11	386
10-389-11	386
10-390-11	386
10-391-12	387
10-392-22	387
10-393-22	387
10-394-12	387
10-396-12	387
10-397-12	387
10-398-17	387
10-399-17	388
10-400-17	388
10-401-16	388
10-402-16	388
10-403-17	388
10-404-16	388
10-405-17	388
10-406-17	388
10-407-15	389
10-408-15	389
10-409-15	389
10-410-16	389
10-411-21	390
10-412-25	390
10-413-18	390
10-414-18	390
10-415-19	391
10-416-25	391
10-417-26	391
10-418-26	391
10-419-27	391
10-420-16	392
10-421-16	392
10-422-14	392
10-423-16	392
10-423-17	392
10-423-20	392
10-423-21	392
10-423-23	392
10-424-16	392

10-424-17	392
10-424-20	392
10-424-21	392
10-424-23	392
10-425-20	393
10-426-19	393
10-427-26	394
10-428-33	394
10-429-31	394
10-430-19	395
10-431-19	395
10-432-19	395
10-433-19	395
10-434-19	395
10-435-19	395
10-430-35	395
10-431-35	395
10-432-35	395
10-433-35	395
10-434-35	395
10-435-35	395
10-436-19	395
10-437-19	395
10-438-19	395
10-439-19	395
10-440-19	395
10-441-19	395
10-436-35	395
10-437-35	395
10-438-35	395
10-439-35	395
10-440-35	395
10-441-35	395
10-430-00	395
10-442-13	396
10-443-13	396
10-444-13	396
10-445-13	396
10-446-13	396
10-447-13	396
10-448-13	396
10-449-13	396
10-442-00	396
10-450-00	397
10-451-00	398

## 11

Dressings	
Verband	
Vendajes	
Pansements	
Bendaggi	
11-300-14	400
11-301-18	400
11-302-20	400
11-303-18	400
11-304-23	400
11-304-26	400
11-304-37	400
11-305-18	400

11-306-24	400
11-307-23	401
11-308-30	402
11-309-28	402

## 12

Cardiovascular Surgery  
 Herz-Kreislauf-Chirurgie  
 Cirugía Cardiovascular  
 Chirurgie cardiovasculaire  
 Chirurgia cardiovascolare

12-500-35	404
12-501-12	404
12-501-15	404
12-502-39	404
12-503-03	404
12-503-05	404
12-503-07	404
12-504-31	405
12-505-23	405
12-506-27	405
12-506-30	405
12-506-34	405
12-507-27	406
12-508-30	406
12-509-28	406
12-510-24	406
12-511-22	406
12-512-12	407
12-512-18	407
12-512-26	407
12-513-20	407
12-514-21	407
12-515-19	407
12-516-18	407
12-517-19	407
12-517-25	407
12-518-16	408
12-519-17	408
12-520-17	408
12-521-24	408
12-522-18	408
12-522-20	408
12-523-24	408
12-524-19	409
12-525-19	409
12-526-18	409
12-527-28	409
12-527-30	409
12-528-22	410
12-529-22	410
12-530-24	410
12-531-26	410
12-532-26	410
12-533-26	410
12-534-26	410
12-535-18	411
12-536-08	411
12-537-08	411
12-538-08	411

12-539-08	411
12-540-09	411
12-541-08	411
12-542-08	411
12-543-08	411
12-544-08	411
12-535-00	411
12-535-18	411
12-540-09	411
12-545-08	412
12-545-10	412
12-545-12	412
12-545-14	412
12-545-16	412
12-546-08	412
12-546-10	412
12-546-12	412
12-546-14	412
12-546-16	412
12-547-08	412
12-547-10	412
12-547-12	412
12-547-14	412
12-547-16	412
12-548-03	412
12-548-04	412
12-548-05	412
12-548-06	412
12-548-07	412
12-548-08	412
12-548-09	412
12-548-10	412
12-549-02	412
12-549-03	412
12-549-04	412
12-549-05	412
12-549-06	412
12-549-07	412
12-549-08	412
12-550-02	412
12-550-03	412
12-550-04	412
12-550-05	412
12-550-06	412
12-550-07	412
12-550-08	412
12-551-02	412
12-551-03	412
12-551-04	412
12-551-05	412
12-551-06	412
12-551-07	412
12-551-08	412
12-552-02	412
12-552-03	412
12-552-04	412
12-552-05	412
12-552-06	412
12-552-07	412
12-552-08	412
12-553-02	412



12-553-03	412
12-553-04	412
12-553-05	412
12-553-06	412
12-553-07	412
12-553-08	412
12-554-02	412
12-554-03	412
12-554-04	412
12-554-05	412
12-554-06	412
12-554-07	412
12-554-08	412
12-555-06	413
12-555-08	413
12-555-10	413
12-555-13	413
12-555-15	413
12-555-20	413
12-555-25	413
12-555-30	413
12-555-38	413
12-555-44	413
12-555-50	413
12-556-06	413
12-556-08	413
12-556-10	413
12-556-13	413
12-556-15	413
12-556-20	413
12-556-25	413
12-556-30	413
12-556-38	413
12-556-44	413
12-556-50	413
12-557-04	413
12-557-06	413
12-557-08	413
12-557-10	413
12-557-12	413
12-557-14	413
12-558-04	413
12-558-06	413
12-558-08	413
12-558-10	413
12-558-12	413
12-558-14	413
12-559-03	413
12-559-04	413
12-559-06	413
12-559-08	413
12-559-10	413
12-559-12	413
12-559-15	413
12-560-03	413
12-560-04	413
12-560-06	413
12-560-08	413
12-560-10	413
12-560-12	413
12-560-15	413

12-561-07	414
12-561-10	414
12-561-15	414
12-561-20	414
12-561-25	414
12-561-30	414
12-562-07	414
12-562-10	414
12-562-15	414
12-562-20	414
12-562-25	414
12-562-30	414
12-563-07	414
12-563-10	414
12-563-15	414
12-563-20	414
12-563-25	414
12-563-30	414
12-564-07	414
12-564-10	414
12-564-15	414
12-564-20	414
12-564-25	414
12-564-30	414
12-565-04	414
12-565-06	414
12-565-08	414
12-565-10	414
15-565-12	414
12-566-04	414
12-566-06	414
12-566-08	414
12-566-10	414
12-566-12	414
12-200-04	415
12-200-05	415
12-200-06	415
12-200-08	415
12-200-10	415
12-200-12	415
12-200-15	415
12-200-20	415
12-200-22	415
12-200-25	415
12-201-04	415
12-201-05	415
12-201-06	415
12-201-08	415
12-201-10	415
12-201-12	415
12-201-15	415
12-201-20	415
12-201-22	415
12-201-25	415
12-202-04	415
12-202-05	415
12-202-06	415
12-202-08	415
12-202-10	415
12-202-12	415
12-202-15	415

12-202-20	415
12-202-22	415
12-202-25	415
12-203-04	415
12-203-05	415
12-203-06	415
12-203-08	415
12-203-10	415
12-203-12	415
12-203-15	415
12-203-20	415
12-203-22	415
12-203-25	415
12-204-05	415
12-204-09	415
12-205-27	416
12-205-27A	416
12-205-27B	416
12-205-27C	416
12-206-06	417
12-206-09	417
12-206-13	417
12-206-16	417
12-206-25	417
12-206-32	417
12-207-06	417
12-207-09	417
12-207-13	417
12-207-16	417
12-207-25	417
12-207-32	417
12-208-06	417
12-208-09	417
12-208-13	417
12-208-16	417
12-208-25	417
12-208-32	417
12-209-06	417
12-209-09	417
12-209-13	417
12-209-16	417
12-209-25	417
12-209-32	417
12-210-06	417
12-210-09	417
12-210-10	417
12-210-11	417
12-210-13	417
12-210-15	417
12-210-16	417
12-210-19	417
12-210-20	417
12-210-25	417
12-210-30	417
12-210-32	417
12-211-06	417
12-211-09	417
12-211-10	417
12-211-11	417
12-211-13	417
12-211-15	417

12-211-16	417
12-211-19	417
12-211-20	417
12-211-25	417
12-211-30	417
12-211-32	417
12-212-06	417
12-212-09	417
12-212-10	417
12-212-11	417
12-212-13	417
12-212-15	417
12-212-16	417
12-212-19	417
12-212-20	417
12-212-25	417
12-212-30	417
12-212-32	417
12-567-10	418
12-567-15	418
12-567-20	418
12-567-25	418
12-568-10	418
12-568-15	418
12-568-20	418
12-568-25	418
12-569-10	418
12-569-15	418
12-569-20	418
12-569-25	418
12-570-10	418
12-570-15	418
12-570-20	418
12-570-25	418
12-571-10	418
12-571-15	418
12-571-20	418
12-571-25	418
12-572-06	418
12-572-09	418
12-572-13	418
12-572-16	418
12-572-19	418
12-572-25	418
12-572-32	418
12-573-06	418
12-573-09	418
12-573-13	418
12-573-16	418
12-573-19	418
12-573-25	418
12-573-32	418
12-574-06	418
12-574-09	418
12-574-13	418
12-574-16	418
12-574-19	418
12-574-25	418
12-574-32	418
12-575-06	418
12-575-09	418

12-575-13	418	12-603-18	421	12-265-06	427	12-218-43	430
12-575-16	418	12-604-18	421	12-265-08	427	12-217-50	430
12-575-19	418	12-605-18	421	12-652-17	428	12-218-50	430
12-575-25	418	12-606-18	421	12-653-17	428	12-219-50	430
12-575-32	418	12-607-18	421	12-654-17	428	12-220-43	430
12-576-06	419	12-608-18	422	12-655-17	428	12-221-43	430
12-576-13	419	12-609-18	422	12-656-17	428	12-220-50	430
12-576-19	419	12-610-18	422	12-657-17	428	12-221-50	430
12-576-25	419	12-611-18	422	12-658-17	428	12-702-21	431
12-576-32	419	12-612-18	422	12-659-17	428	12-703-21	431
12-577-06	419	12-613-18	422	12-660-17	428	12-704-21	431
12-577-13	419	12-614-20	423	12-661-17	428	12-705-17	431
12-577-19	419	12-615-20	423	12-662-17	428	12-706-17	431
12-577-25	419	12-616-20	423	12-663-17	428	12-707-23	431
12-577-32	419	12-617-20	423	12-664-17	428	12-708-23	431
12-578-06	419	12-618-19	423	12-665-17	428	12-709-23	431
12-578-13	419	12-619-19	423	12-666-17	428	12-710-23	431
12-578-19	419	12-620-16	423	12-667-17	428	12-711-23	431
12-578-25	419	12-621-16	423	12-668-17	428	12-712-23	431
12-578-32	419	12-622-16	423	12-669-17	429	12-713-23	431
12-579-06	419	12-623-16	423	12-670-17	429	12-714-23	431
12-579-13	419	12-624-16	423	12-671-17	429	12-715-30	432
12-579-19	419	12-625-16	423	12-672-17	429	12-716-30	432
12-579-25	419	12-626-16	423	12-673-17	429	12-717-30	432
12-579-32	419	12-627-16	423	12-674-17	429	12-718-30	432
12-580-06	419	12-628-18	424	12-675-17	429	12-719-30	432
12-580-13	419	12-629-18	424	12-676-17	429	12-720-30	432
12-580-19	419	12-630-18	424	12-677-17	429	12-721-24	432
12-580-25	419	12-631-20	424	12-678-16	429	12-722-24	432
12-580-32	419	12-632-20	424	12-679-16	429	12-723-24	432
12-581-15	419	12-633-20	424	12-680-16	429	12-724-24	432
12-582-16	419	12-634-23	425	12-681-16	429	12-725-25	432
12-583-04	419	12-635-21	425	12-682-16	429	12-726-25	432
12-583-06	419	12-636-21	425	12-683-16	429	12-727-25	432
12-583-08	419	12-637-15	426	12-684-16	429	12-728-25	432
12-584-03	419	12-638-15	426	12-685-16	429	12-729-25	432
12-584-04	419	12-639-15	426	12-686-16	429	12-730-25	432
12-584-06	419	12-640-15	426	12-687-18	430	12-731-20	433
12-584-08	419	12-641-15	426	12-688-18	430	12-732-20	433
12-585-03	419	12-642-15	426	12-689-18	430	12-733-20	433
12-585-04	419	12-643-15	426	12-690-18	430	12-734-20	433
12-585-06	419	12-644-12	426	12-691-18	430	12-735-20	433
12-585-08	419	12-645-12	426	12-692-18	430	12-736-20	433
12-586-16	420	12-646-20	426	12-693-19	430	12-737-20	433
12-587-16	420	12-647-20	426	12-694-19	430	12-738-20	433
12-588-07	420	12-648-20	426	12-695-19	430	12-739-20	433
12-588-12	420	12-649-20	426	12-696-19	430	12-740-20	433
12-589-19	420	12-650-20	426	12-697-27	430	12-741-20	433
12-590-18	420	12-651-20	426	12-698-27	430	12-742-20	433
12-591-17	420	12-262-03	427	12-699-27	430	12-743-20	433
12-592-17	420	12-262-05	427	12-700-27	430	12-744-20	433
12-593-17	420	12-262-08	427	12-701-27	430	12-746-20	433
12-594-17	420	12-263-12	427	12-213-43	430	12-747-20	433
12-595-17	420	12-263-14	427	12-214-43	430	12-748-20	433
12-596-18	421	12-263-16	427	12-215-43	430	12-749-20	433
12-597-18	421	12-264-03	427	12-216-43	430	12-750-25	433
12-598-18	421	12-264-04	427	12-216-50	430	12-751-25	433
12-599-18	421	12-264-05	427	12-213-50	430	12-752-25	433
12-600-18	421	12-264-06	427	12-214-50	430	12-753-25	433
12-601-18	421	12-265-02	427	12-215-50	430	12-754-20	433
12-602-18	421	12-265-06	427	12-217-43	430	12-756-20	433

12-757-20	433
12-758-20	433
12-759-25	434
12-760-25	434
12-761-25	434
12-762-21	434
12-763-21	434
12-764-21	434
12-765-21	434
12-766-21	434
12-251-01	435
12-251-02	435
12-251-03	435
12-252-01	435
12-253-02	435
12-254-03	435
12-255-01	435
12-255-02	435
12-255-03	435
12-256-01	435
12-256-02	435
12-256-03	435
12-257-01	435
12-257-02	435
12-257-03	435
12-258-01	435
12-258-02	435
12-258-03	435
12-259-01	435
12-259-02	435
12-259-03	435
12-260-01	435
12-260-02	435
12-260-03	435
12-261-01	435
12-261-02	435
12-261-03	435
12-767-13	436
12-767-14	436
12-767-16	436
12-767-17	436
12-767-20	436
12-768-13	436
12-768-14	436
12-768-16	436
12-768-17	436
12-768-20	436
12-769-21	436
12-770-13	437
12-771-13	437
12-772-13	437
12-773-15	437
12-774-15	437
12-775-15	437
12-776-13	437
12-777-13	437
12-778-13	437
12-779-15	437
12-780-15	437
12-781-15	437
12-262-14	437

12-782-17	438
12-783-17	438
12-784-17	438
12-785-17	438
12-786-20	438
12-787-20	438
12-788-20	438
12-789-21	438
12-790-21	438
12-791-17	439
12-792-23	439
12-793-18	439
12-794-14	439
12-795-17	440
12-796-17	440
12-797-17	440
12-798-17	440
12-799-19	440
12-800-15	440
12-801-15	440
12-802-15	440
12-803-15	441
12-804-21	441
12-805-19	441
12-806-18	441
12-806-21	441
12-807-13	441
12-807-19	441
12-808-15	442
12-809-15	442
12-810-05	442
12-810-10	442
12-810-15	442
12-810-20	442
12-810-25	442
12-811-17	442
12-812-17	442
12-813-17	442
12-814-17	442
12-815-13	443
12-816-16	443
12-817-16	443
12-818-16	443
12-819-16	443
12-820-16	443
12-821-16	443
12-822-15	444
12-823-15	444
12-824-18	444
12-825-18	444
12-826-17	444
12-827-21	444
12-828-17	444
12-829-21	444
12-830-22	444
12-831-22	444
12-832-21	445
12-833-18	445
12-834-19	445
12-835-20	445
12-836-20	445

12-837-20	445
12-838-17	445
12-839-17	445
12-222-17	446
12-223-19	446
12-224-16	446
12-225-19	446
12-226-14	446
12-227-14	446
12-228-19	447
12-229-06	447
12-229-08	447
12-230-18	447
12-231-18	447
12-232-17	448
12-233-17	448
12-234-17	448
12-235-17	448
12-236-05	448
12-236-07	448
12-237-05	448
12-237-07	448
12-238-03	448
12-238-04	448
12-238-06	448
12-238-07	448
12-238-08	448
12-238-09	448
12-239-03	448
12-239-04	448
12-239-06	448
12-239-07	448
12-239-08	448
12-239-09	448
12-240-06	448
12-240-07	448
12-240-08	448
12-240-09	448
12-241-03	448
12-241-06	448
12-241-07	448
12-241-08	448
12-241-09	448
12-242-03	448
12-242-04	448
12-242-05	448
12-242-06	448
12-243-03	448
12-243-04	448
12-243-05	448
12-243-06	448
12-244-03	448
12-244-04	448
12-244-05	448
12-244-06	448
12-245-45	449
12-245-90	449
12-246-06	449
12-247-06	449
12-247-10	449
12-247-13	449

12-840-29	450
12-841-29	450
12-842-29	450
12-843-18	450
12-844-19	450
12-845-19	450
12-846-20	450
12-847-21	450
12-848-20	451
12-849-20	451
12-850-20	451
12-851-18	451
12-852-18	451
12-853-18	451
12-248-19	451
12-249-19	451
12-854-22	452
12-855-22	452
12-856-24	452
12-857-24	452
12-858-24	453
12-859-26	453
12-860-28	453
12-861-26	453
12-862-26	453
12-863-16	454
12-864-16	454
12-865-14	454
12-866-14	454
12-867-14	454
12-868-23	454
12-869-21	454
12-870-24	455
12-871-24	455
12-872-34	455
12-873-26	455
12-874-26	455
12-875-26	455
12-876-28	455
12-877-16	456
12-878-17	456
12-879-16	456
12-880-16	456
12-881-19	456
12-882-17	456
12-883-17	456
12-884-17	456
12-885-20	457
12-886-20	457
12-887-22	457
12-888-22	457
12-889-18	457
12-890-23	458
12-891-23	458
12-892-23	458
12-893-15	458
12-894-15	458
12-895-15	458
12-896-15	458
12-897-15	458
12-898-31	459

12-899-23	459	12-958-14	470	12-998-25	479	12-132-17	487
12-900-20	459	12-958-17	470	12-998-28	479	12-133-18	488
12-901-15	460	12-958-19	470	12-999-23	479	12-134-18	488
12-902-19	460	12-958-22	470	12-999-25	479	12-135-18	488
12-903-24	460	12-959-14	470	12-999-28	479	12-135-20	488
12-904-13	460	12-959-17	470	12-100-16	479	12-135-24	488
12-905-15	460	12-959-19	470	12-100-24	479	12-136-20	488
12-906-15	460	12-959-22	470	12-101-13	480	12-137-24	488
12-907-15	461	12-960-16	470	12-102-17	480	12-138-01	489
12-908-15	461	12-961-16	470	12-103-20	480	12-138-02	489
12-909-17	461	12-962-18	470	12-104-13	480	12-138-03	489
12-910-17	461	12-963-18	470	12-105-16	481	12-139-18	490
12-911-15	461	12-964-27	471	12-106-9	481	12-140-01	490
12-912-15	461	12-965-27	471	12-107-9	481	12-140-02	490
12-913-15	461	12-966-27	471	12-108-18	481	12-140-03	490
12-914-18	461	12-967-24	471	12-109-21	481	12-140-04	490
12-915-18	461	12-968-27	471	12-110-32	482	12-140-05	490
12-916-12	462	12-969-18	472	12-110-45	482	12-141-13	490
12-917-14	462	12-969-20	472	12-110-62	482	12-141-18	490
12-918-19	462	12-969-22	472	12-111-28	482	12-141-22	490
12-919-20	462	12-970-15	472	12-112-21	483	12-142-18	491
12-920-21	462	12-971-13	472	12-113-13	483	12-142-27	491
12-921-19	463	12-972-17	472	12-114-01	483	12-143-01	491
12-922-19	463	12-973-14	472	12-114-02	483	12-143-02	491
12-923-17	463	12-974-21	473	12-114-03	483	12-143-03	491
12-924-17	463	12-975-23	473	12-114-04	483	12-143-04	491
12-925-20	463	12-976-21	473	12-114-05	483	12-144-19	491
12-926-17	463	12-977-19	473	12-114-06	483	12-145-22	492
12-927-16	464	12-978-19	474	12-114-07	483	12-146-22	492
12-928-17	464	12-979-20	474	12-114-08	483	12-147-16	493
12-929-14	464	12-980-20	474	12-114-09	483	12-148-16	493
12-930-15	464	12-981-23	474	12-114-10	483	12-149-16	493
12-931-15	464	12-982-26	474	12-114-11	483	12-150-20	494
12-932-18	464	12-983-26	474	12-115-01	483	12-151-01	494
12-933-20	464	12-984-19	475	12-115-02	483	12-152-02	494
12-934-18	465	12-985-20	475	12-115-03	483	12-153-03	494
12-935-18	465	12-986-20	475	12-115-04	483	12-154-04	494
12-936-18	465	12-987-21	475	12-115-05	483	12-155-07	494
12-937-17	465	12-987-27	475	12-116-22	484	12-156-08	494
12-938-23	466	12-987-30	475	12-117-22	484	12-157-09	494
12-939-23	466	12-988-17	476	12-118-23	484	12-158-10	494
12-940-23	466	12-989-25	476	12-118-23	484	12-159-11	494
12-941-23	466	12-990-26	476	12-119-18	485	12-160-12	494
12-942-23	466	12-991-27	476	12-120-18	485	12-161-28	495
12-943-24	466	12-992-17	476	12-121-15	485	12-162-00	495
12-944-24	466	12-992-21	476	12-122-14	485	12-163-28	495
12-945-24	466	12-993-17	476	12-122-18	485	12-164-01	496
12-946-22	466	12-993-21	476	12-125-16	486	12-164-02	496
12-947-22	466	12-994-33	477	12-123-57	486	12-164-01	496
12-948-23	467	12-994-45	477	12-124-18	486	12-164-02	496
12-949-24	467	12-995-33	477	12-125-26	486	12-164-03	496
12-950-23	467	12-995-45	477	12-126-13	487	12-164-04	496
12-951-23	467	12-996-22	478	12-126-18	487	12-164-05	496
12-952-24	467	12-996-27	478	12-127-14	487	12-164-05	496
12-953-30	468	12-996-30	478	12-127-17	487	12-164-06	496
12-954-30	468	12-997-15	478	12-128-05	487	12-164-07	496
12-955-27	468	12-997-19	478	12-128-05	487	12-164-08	496
12-956-27	468	12-997-24	478	12-129-05	487	12-164-09	496
12-250-08	469	12-997-26	478	12-129-07	487	12-165-01	496
12-250-12	469	12-997-28	478	12-130-22	487	12-165-02	496
12-957-19	470	12-998-23	479	12-131-19	487	12-165-03	496

12-165-04	496
12-165-05	496
12-165-06	496
12-165-07	496
12-165-08	496
12-165-09	496
12-165-10	496
12-165-11	496
12-165-12	496
12-166-18	496
12-166-21	496
12-167-14	496
12-168-14	496

## 13

Micro – Neurosurgery  
Mikro – Neurochirurgie  
Micro – Neurocirugia  
Micro – Neurochirurgie  
Micro – Neurochirurgia

13-700-00	498
13-701-00	498
13-702-00	498
13-703-00	498
13-704-00	498
13-705-00	498
13-706-00	498
13-707-27	499
13-708-27	499
13-709-01	499
13-710-02	499
13-711-03	499
13-712-04	499
13-713-04	499
13-714-04	499
13-707-01	499
13-707-02	499
13-707-27	499
13-707-27	499
13-715-15	500
13-716-21	500
13-717-33	500
13-718-30	500
13-718-40	500
13-718-50	500
13-718-60	500
13-718-70	500
13-719-30	500
13-719-40	500
13-719-50	500
13-720-00	500
13-721-00	501
13-722-00	501
13-723-00	502
13-724-00	502
13-725-00	502
13-726-00	502
13-727-00	502
13-428-00	503
13-429-00	503

13-430-0	503
13-431-00	503
13-432-00	503
13-433-00	504
13-434-00	504
13-435-00	504
13-436-00	504
13-437-00	504
13-438-00	505
13-439-00	505
13-440-00	506
13-441-00	506
13-442-00	506
13-443-00	506
13-444-00	506
13-445-00	506
13-446-00	506
13-447-00	506
13-448-12	507
13-448-17	507
13-448-20	507
13-448-25A	507
13-448-25B	507
13-452-08	507
13-452-11	507
13-452-14	507
13-452-17	507
13-457-07	507
13-457-10	507
13-457-13	507
13-457-16	507
13-457-19	507
13-457-22	507
13-458-06	507
13-458-10	507
13-458-14	507
13-458-16	507
13-458-19	507
13-458-25	507
13-458-32	507
13-458-38	507
13-459-10	507
13-459-16	507
13-728-07	508
13-728-11	508
13-728-15	508
13-728-18	508
13-729-07	508
13-729-11	508
13-729-15	508
13-729-18	508
13-730-07	508
13-730-11	508
13-730-15	508
13-730-18	508
13-731-08	508
13-731-11	508
13-731-14	508
13-731-17	508
13-731-20	508
13-227-04	508

13-227-06	508
13-227-08	508
13-227-10	508
13-732-15	509
13-732-19	509
13-733-15	509
13-733-19	509
13-734-14	509
13-735-00	509
13-736-14	510
13-737-15	510
13-738-15	510
13-739-15	510
13-740-07	511
13-740-09	511
13-740-11	511
13-741-07	511
13-741-09	511
13-741-11	511
13-742-07	511
13-742-09	511
13-742-11	511
13-743-07	511
13-743-09	511
13-743-11	511
13-744-07	512
13-744-09	512
13-744-11	512
13-745-07	512
13-745-09	512
13-745-11	512
13-746-07	512
13-746-09	512
13-746-11	512
13-747-07	512
13-747-09	512
13-747-11	512
13-748-07	513
13-748-09	513
13-748-11	513
13-748-13	513
13-749-07	513
13-749-09	513
13-749-11	513
13-749-13	513
13-750-07	513
13-750-09	513
13-750-11	513
13-750-13	513
13-751-07	513
13-751-09	513
13-751-11	513
13-751-13	513
13-752-07	514
13-752-08	514
13-752-09	514
13-752-10	514
13-753-07	514
13-753-08	514
13-753-09	514
13-753-10	514

13-754-07	514
13-754-08	514
13-754-09	514
13-754-10	514
13-755-07	514
13-755-08	514
13-755-09	514
13-755-10	514
13-756-00	515
13-756-00T	515
13-757-00	515
13-757-00T	515
13-758-00	515
13-759-00	515
13-759-00T	515
13-760-00	515
13-761-00	515
13-762-00	515
13-763-00	515
13-764-00	515
13-765-00	515
13-766-00	515
13-767-00	515
13-768-00	515
13-769-00	515
13-770-00	515
13-771-00	515
13-772-00	515
13-773-00	515
13-774-00	515
13-775-00	515
13-766-00	516
13-777-00	516
13-778-00	516
13-779-00	516
13-780-00	516
13-781-00	516
13-782-00	516
13-783-00	516
13-784-00	516
13-785-00	516
13-786-00	516
13-787-00	516
13-788-00	516
13-789-00	516
13-790-00	516
13-791-00	516
13-792-00	516
13-793-00T	516
13-794-00	517
13-795-00	517
13-796-00	517
13-797-00	517
13-798-00	517
13-799-00	517
13-800-00	517
13-801-00	517
13-802-00	517
13-803-00	518
13-804-00	518
13-805-00	518

13-806-00	518	13-867-00	522	13-922-19	529	13-980-14	534
13-807-00	518	13-868-00	522	13-923-19	529	13-981-17	535
13-808-00	518	13-869-23	523	13-924-19	529	13-982-17	535
13-809-00	518	13-870-24	523	13-925-19	529	13-983-17	535
13-810-00	518	13-871-20	523	13-926-19	529	13-984-17	535
13-811-00	518	13-872-21	523	13-927-19	529	13-985-17	535
13-812-00	518	13-873-01	524	13-928-19	529	13-986-17	535
13-813-00	518	13-874-02	524	13-929-19	529	13-987-17	535
13-814-00	518	13-875-20	524	13-930-19	529	13-988-17	535
13-815-00	519	13-876-17	524	13-931-19	529	13-989-17	535
13-816-00	519	13-876-21	524	13-932-22	529	13-990-17	535
13-817-00	519	13-877-22	524	13-933-22	529	13-991-14	536
13-818-00	519	13-878-19	524	13-934-22	529	13-991-18	536
13-819-00	519	13-878-28	524	13-935-22	529	13-992-14	536
13-820-00	519	13-879-19	524	13-936-22	529	13-992-18	536
13-821-00	519	13-879-28	524	13-937-22	529	13-993-14	536
13-822-00	519	13-880-18	525	13-938-19	530	13-993-18	536
13-823-00	519	13-881-18	525	13-939-19	530	13-994-14	536
13-824-00	519	13-882-17	525	13-940-19	530	13-994-18	536
13-825-00	519	13-883-01	525	13-941-19	530	13-995-14	536
13-826-00	519	13-883-02	525	13-942-19	530	13-995-18	536
13-827-00	519	13-885-15	525	13-943-19	530	13-996-14	536
13-828-00	519	13-886-20	525	13-944-19	530	13-996-18	536
13-829-00	519	13-887-20	525	13-945-19	530	13-997-14	536
13-830-00	519	13-888-20	525	13-946-19	530	13-997-18	536
13-831-00	519	13-889-20	525	13-947-19	530	13-998-14	536
13-832-00	520	13-890-20	525	13-948-19	530	13-998-18	536
13-833-00	520	13-891-19	526	13-949-19	530	13-999-12	537
13-834-00	520	13-892-19	526	13-950-19	530	13-100-12	537
13-835-00T	520	12-893-19	526	13-951-25	531	13-101-15	537
13-836-00	520	13-894-31	526	13-952-25	531	13-102-15	537
13-837-00	520	13-894-41	526	13-953-25	531	13-103-15	537
13-838-00	520	13-895-14	526	13-954-25	531	13-104-15	537
13-839-00	520	13-896-13	526	13-955-27	531	13-105-08	537
13-840-00	520	13-896-18	526	13-956-27	531	13-105-10	537
13-841-00	520	13-897-13	526	13-957-08	532	13-106-08	537
13-842-00	520	13-897-18	526	13-958-08	532	13-106-10	537
13-843-00	521	13-898-01	526	13-959-12	532	13-107-08	537
13-844-00	521	13-899-01	527	13-960-12	532	13-107-18	537
13-845-00	521	13-900-00	527	13-961-12	532	13-108-18	537
13-846-00	521	13-901-00	527	13-962-12	532	13-108-08	537
13-847-00	521	13-902-00	527	13-963-12	532	13-109-18	537
13-848-00	521	13-903-00	527	13-964-12	532	13-109-08	537
13-849-00	521	13-904-00	527	13-965-15	533	13-110-18	537
13-850-00	521	13-905-01	527	13-966-15	533	13-110-08	537
13-851-00	521	13-906-01	527	13-967-15	533	13-111-17	538
13-852-00	521	13-907-01	527	13-968-15	533	13-112-17	538
13-853-00	521	13-908-21	528	13-969-18	533	13-113-17	538
13-854-00	521	13-909-21	528	13-969-15	533	13-114-17	538
13-855-00	521	13-910-21	528	13-970-15	533	13-115-17	538
13-856-00	521	13-911-20	528	13-970-18	533	13-116-18	538
13-857-00	521	13-912-29	528	13-971-15	533	13-117-18	538
13-858-00	521	13-913-17	528	13-971-18	533	13-118-18	538
13-859-00	521	13-914-19	528	13-972-18	533	13-119-18	538
13-860-00	521	13-915-19	528	13-973-18	533	13-120-18	538
13-861-00	521	13-916-21	528	13-974-18	533	13-121-18	539
13-862-00	521	13-917-18	528	13-975-12	534	13-122-18	539
13-863-00	522	13-918-19	529	13-976-12	534	13-123-18	539
13-864-00	522	13-919-19	529	13-977-12	534	13-124-18	539
13-865-00	522	13-920-19	529	13-978-12	534	13-125-18	539
13-866-00	522	13-921-19	529	13-979-14	534	13-126-18	539

13-127-18	539
13-128-18	539
13-129-18	539
13-130-18	539
13-131-15	539
13-132-15	539
13-133-16	540
13-133-18	540
13-134-16	540
13-134-18	540
13-135-16	540
13-135-18	540
13-136-16	540
13-136-18	540
13-137-16	540
13-137-18	540
13-138-16	540
13-138-18	540
13-139-16	540
13-139-18	540
13-139-22	540
13-139-18	540
13-140-18	540
13-140-22	540
13-141-22	540
13-142-22	540
13-143-20	541
13-143-22	541
13-144-20	541
13-144-22	541
13-145-20	541
13-145-22	541
13-146-20	541
13-146-22	541
13-147-20	541
13-147-22	541
13-148-20	541
13-148-22	541
13-149-20	541
13-149-22	541
13-150-20	541
13-150-22	541
13-156-12	542
13-156-13	542
13-157-11	542
13-158-11	542
13-159-15	543
13-160-15	543
13-161-18	543
13-162-18	543
13-163-18	543
13-164-18	543
13-165-18	543
13-166-18	543
13-167-18	543
13-168-18	543
13-169-18	543
13-170-18	543
13-171-18	543
13-172-18	543
13-173-18	543

13-174-18	543
13-175-18	543
13-176-18	543
13-177-15	544
13-177-18	544
13-177-21	544
13-177-23	544
13-178-15	544
13-178-18	544
13-178-21	544
13-178-23	544
13-179-15	544
13-179-18	544
13-179-21	544
13-179-23	544
13-180-15	544
13-180-18	544
13-180-21	544
13-180-23	544
13-181-15	544
13-181-18	544
13-181-21	544
13-181-23	544
13-182-15	544
13-182-18	544
13-182-21	544
13-182-23	544
13-183-15	544
13-183-18	544
13-183-21	544
13-183-23	544
13-184-15	544
13-184-18	544
13-184-21	544
13-184-23	544
13-185-15	544
13-185-18	544
13-185-21	544
13-185-23	544
13-186-15	544
13-186-18	544
13-186-21	544
13-186-23	544
13-187-15	544
13-187-18	544
13-187-21	544
13-187-23	544
13-188-15	544
13-188-18	544
13-188-21	544
13-188-23	544
13-189-15	545
13-189-18	545
13-189-21	545
13-189-23	545
13-190-15	545
13-190-18	545
13-190-21	545
13-190-23	545
13-191-15	545
13-191-18	545

13-191-21	545
13-191-23	545
13-192-15	545
13-192-18	545
13-192-21	545
13-192-23	545
13-193-15	545
13-193-18	545
13-193-21	545
13-193-23	545
13-194-15	545
13-194-18	545
13-194-21	545
13-194-23	545
13-195-15	545
13-195-18	545
13-195-21	545
13-195-23	545
13-196-15	545
13-196-18	545
13-196-21	545
13-196-23	545
13-197-15	545
13-197-18	545
13-197-21	545
13-197-23	545
13-198-15	545
13-198-18	545
13-198-21	545
13-198-23	545
13-199-15	545
13-199-18	545
13-199-21	545
13-199-23	545
13-200-15	545
13-200-18	545
13-200-21	545
13-200-23	545
13-201-16	546
13-201-18	546
13-202-16	546
13-202-18	546
13-203-16	546
13-203-18	546
13-204-16	546
13-204-18	546
13-205-16	546
13-205-18	546
13-206-16	546
13-206-18	546
13-207-16	546
13-207-18	546
13-208-16	546
13-208-18	546
13-209-22A	546
13-209-22B	546
13-210-22A	546
13-210-22B	546
13-211-22A	546
13-211-22B	546
13-212-20	547

13-212-22	547
13-213-20	547
13-213-22	547
13-214-20	547
13-214-22	547
13-215-20	547
13-215-22	547
13-216-22	547
13-217-22	547
13-218-20	547
13-218-22	547
13-219-20	547
13-219-22	547
13-220-21	548
13-220-23	548
13-221-21	548
13-221-23	548
13-222-21	548
13-222-23	548
13-223-21	548
13-223-23	548
13-224-21	548
13-224-23	548
13-225-21	548
13-225-23	548
13-226-21	548
13-226-23	548
13-227-21	548
13-227-23	548
13-228-15	549
13-228-18	549
13-228-21	549
13-228-23	549
13-229-15	549
13-229-18	549
13-229-21	549
13-229-23	549
13-230-15	549
13-230-18	549
13-230-21	549
13-230-23	549
13-231-15	549
13-231-18	549
13-231-21	549
13-231-23	549
13-232-15	549
13-232-18	549
13-232-21	549
13-232-23	549
13-233-15	549
13-233-18	549
13-233-21	549
13-233-23	549
13-234-15	549
13-234-18	549
13-234-21	549
13-234-23	549
13-235-15	549
13-235-18	549
13-235-21	549
13-235-23	549

13-236-15	549	13-267-18	553	13-302-02	556	13-340-18	562
13-236-18	549	13-268-18	553	13-302-03	556	13-341-18	562
13-236-21	549	13-269-18	553	13-302-04	556	13-342-23	563
13-236-23	549	13-270-18	553	13-302-05	556	13-343-23	563
13-237-15	549	13-271-18	553	13-302-06	556	13-344-23	563
13-237-18	549	13-272-18	553	13-302-07	556	13-345-23	563
13-237-21	549	13-273-18	553	13-303-14	557	13-346-23	563
13-237-23	549	13-274-18	554	13-304-14	557	13-347-23	563
13-238-15	549	13-274-20	554	13-305-14	557	13-348-23	563
13-238-18	549	13-275-18	554	13-306-14	557	13-349-23	563
13-238-21	549	13-275-20	554	13-307-14	557	13-350-23	563
13-238-23	549	13-276-18	554	13-308-14	557	13-351-23	563
13-239-15	549	13-276-20	554	13-309-14	557	13-352-23	563
13-239-18	549	13-277-18	554	13-310-14	557	13-353-23	563
13-239-21	549	13-277-20	554	13-311-15	557	13-354-23	563
13-239-23	549	13-278-18	554	13-312-18	558	13-355-23	563
13-240-21	550	13-278-20	554	13-313-18	558	13-356-23	563
13-240-23	550	13-279-18	554	13-314-18	558	13-357-23	563
13-241-21	550	13-279-20	554	13-315-18	558	13-358-01	564
13-241-23	550	13-280-18	554	13-316-20	559	13-358-02	564
13-242-21	550	13-280-20	554	13-317-20	559	13-358-03	564
13-242-23	550	13-281-18	554	13-318-20	559	13-358-04	564
13-243-21	550	13-281-20	554	13-319-20	559	13-358-05	564
13-243-23	550	13-282-21	555	13-320-20	559	13-358-06	564
13-244-21	550	13-283-21	555	13-321-20	559	13-359-01	564
13-244-23	550	13-284-21	555	13-322-01	560	13-359-02	564
13-245-21	550	13-285-21	555	13-322-02	560	13-359-03	564
13-245-23	550	13-286-21	555	13-323-01	560	13-359-04	564
13-246-15	551	13-287-21	555	13-323-02	560	13-359-05	564
13-246-18	551	13-288-21	555	13-324-22	560	13-359-06	564
13-246-21	551	13-289-21	555	13-325-22	560	13-360-01	564
13-246-23	551	13-290-21	555	13-326-20	561	13-360-02	564
13-247-15	551	13-291-21	555	13-326-22	561	13-360-03	564
13-247-18	551	13-292-21	555	13-326-24	561	13-360-04	564
13-247-21	551	13-293-21	555	13-327-20	561	13-360-05	564
13-247-23	551	13-295-21	555	13-327-22	561	13-360-06	564
13-248-15	551	13-296-21	555	13-327-24	561	13-361-01	564
13-248-18	551	13-297-21	555	13-328-20	561	13-361-02	564
13-248-21	551	13-298-21	555	13-328-22	561	13-361-03	564
13-248-23	551	13-299-01	556	13-328-24	561	13-361-04	564
13-249-15	551	13-299-02	556	13-329-20	561	13-361-05	564
13-249-18	551	13-299-03	556	13-329-22	561	13-361-06	564
13-249-21	551	13-299-04	556	13-329-24	561	13-362-07	564
13-249-23	551	13-299-05	556	13-330-20	561	13-362-08	564
13-250-14	552	13-299-06	556	13-332-22	561	13-362-09	564
13-251-14	552	13-299-07	556	13-330-24	561	13-362-10	564
13-252-14	552	13-300-01	556	13-331-20	561	13-362-11	564
13-253-14	552	13-300-02	556	13-331-22	561	13-362-12	564
13-254-14	552	13-300-03	556	13-331-24	561	13-363-07	564
13-255-14	552	13-300-04	556	13-332-20	561	13-363-08	564
13-256-14	552	13-300-05	556	13-332-22	561	13-363-09	564
13-257-14	552	13-300-06	556	13-332-24	561	13-363-10	564
13-258-18	553	13-300-07	556	13-333-20	561	13-363-11	564
13-259-18	553	13-301-01	556	13-333-22	561	13-363-12	564
13-260-18	553	13-301-02	556	13-333-24	561	13-364-07	564
13-261-18	553	13-301-03	556	13-334-18	562	13-364-08	564
13-262-18	553	13-301-04	556	13-335-18	562	13-364-09	564
13-263-18	553	13-301-05	556	13-336-18	562	13-364-10	564
13-264-18	553	13-301-06	556	13-337-18	562	13-364-11	564
13-265-18	553	13-301-07	556	13-338-18	562	13-364-12	564
13-266-18	553	13-302-01	556	13-339-18	562	13-365-07	564



13-365-08	564
13-365-09	564
13-365-10	564
13-365-11	564
13-365-12	564
13-366-13	564
13-366-14	564
13-366-15	564
13-366-16	564
13-366-17	564
13-366-18	564
13-367-13	564
13-367-14	564
13-367-15	564
13-367-16	564
13-367-17	564
13-367-18	564
13-368-13	564
13-368-14	564
13-368-15	564
13-368-16	564
13-368-17	564
13-368-18	564
13-369-13	564
13-369-14	564
13-369-15	564
13-369-16	564
13-369-17	564
13-370-19	564
13-370-20	564
13-370-21	564
13-370-22	564
13-370-23	564
13-370-24	564
13-371-01	564
13-371-02	564
13-371-03	564
13-371-04	564
13-371-05	564
13-371-06	564
13-371-11	564
13-371-22	564
13-371-33	564
13-371-44	564
13-371-55	564
13-371-66	564
13-372-01	565
13-372-02	565
13-372-03	565
13-372-04	565
13-372-05	565
13-372-06	565
13-372-07	565
13-372-08	565
13-372-09	565
13-372-10	565
13-372-11	565
13-372-12	565
13-373-01	565
13-373-02	565
13-373-03	565

13-373-04	565
13-373-05	565
13-373-06	565
13-374-01	565
13-374-02	565
13-374-03	565
13-374-04	565
13-374-05	565
13-374-06	565
13-374-07	565
13-374-08	565
13-374-09	565
13-374-10	565
13-374-11	565
13-374-12	565
13-375-01	565
13-375-02	565
13-375-03	565
13-375-04	565
13-375-05	565
13-375-06	565
13-376-01	565
13-376-02	565
13-376-03	565
13-376-04	565
13-376-05	565
13-376-06	565
13-376-13	565
13-376-14	565
13-376-15	565
13-376-16	565
13-376-17	565
13-376-18	565
13-377-01	565
13-377-02	565
13-377-03	565
13-377-04	565
13-377-05	565
13-377-06	565
13-376-07	565
13-376-08	565
13-376-09	565
13-376-10	565
13-376-11	565
13-376-12	565
13-376-19	565
13-376-20	565
13-376-21	565
13-376-22	565
13-376-23	565
13-376-24	565
13-377-11	565
13-377-12	565
13-377-07	565
13-377-08	565
13-377-09	565
13-377-10	565
13-677-01	566
13-678-01	566
13-677-02	566
13-678-02	566

13-677-03	566
13-678-03	566
13-677-04	566
13-678-04	566
13-677-05	566
13-678-05	566
13-677-06	566
13-678-06	566
13-679-01	566
13-680-01	566
13-679-02	566
13-680-02	566
13-680-03	566
13-679-03	566
13-679-04	566
13-680-04	566
13-679-05	566
13-680-05	566
13-680-06	566
13-679-06	566
13-681-01	567
13-681-02	567
13-681-03	567
13-681-04	567
13-681-05	567
13-681-06	567
13-682-01	567
13-682-02	567
13-682-03	567
13-682-04	567
13-682-05	567
13-682-06	567
13-683-01	567
13-683-02	567
13-683-03	567
13-683-04	567
13-683-05	567
13-683-06	567
13-684-01	567
13-684-02	567
13-684-03	567
13-684-04	567
13-684-05	567
13-684-06	567
13-685-01	567
13-685-02	567
13-685-03	567
13-685-04	567
13-685-05	567
13-685-06	567
13-686-01	567
13-686-02	567
13-686-03	567
13-686-04	567
13-686-05	567
13-686-06	567
13-723-02	568
13-723-03	568
13-723-04	568
13-723-05	568
13-724-01	568

13-724-02	568
13-724-03	568
13-724-04	568
13-724-05	568
13-725-02	568
13-725-03	568
13-725-04	568
13-725-05	568
13-726-02	568
13-726-03	568
13-726-04	568
13-726-05	568
13-727-02	568
13-727-03	568
13-727-04	568
13-727-05	568
13-728-01	568
13-728-02	568
13-728-03	568
13-728-04	568
13-728-05	568
13-729-02	568
13-729-03	568
13-729-04	568
13-729-05	568
13-730-02	568
13-730-03	568
13-730-04	568
13-730-05	568
13-731-02	568
13-731-03	568
13-731-04	568
13-731-05	568
13-732-01	568
13-732-02	568
13-732-03	568
13-732-04	568
13-732-05	568
13-733-02	568
13-733-03	568
13-733-04	568
13-733-05	568
13-001-02	568
13-001-03	568
13-001-04	568
13-001-05	568
13-002-02	568
13-002-03	568
13-002-04	568
13-002-05	568
13-734-01	568
13-734-02	568
13-734-03	568
13-734-04	568
13-734-05	568
13-003-02	568
13-003-03	568
13-003-04	568
13-003-05	568
13-004-02	568
13-004-03	568

13-004-04	568	13-744-04	569	13-754-06	571	13-766-03	572
13-004-05	568	13-745-04	569	13-755-06	571	13-765-04	572
13-735-01	569	13-746-04	569	13-756-01	571	13-766-04	572
13-736-01	569	13-744-05	569	13-757-01	571	13-765-05	572
13-737-01	569	13-745-05	569	13-758-01	571	13-766-05	572
13-735-02	569	13-746-05	569	13-756-02	571	13-765-06	572
13-736-02	569	13-744-06	569	13-757-02	571	13-766-06	572
13-737-02	569	13-745-06	569	13-758-02	571	13-667-01	572
13-737-03	569	13-746-06	569	13-756-03	571	13-668-01	572
13-735-04	569	13-247-01	570	13-757-03	571	13-667-02	572
13-737-04	569	13-748-01	570	13-758-03	571	13-668-02	572
13-736-04	569	13-749-01	570	13-756-04	571	13-667-03	572
13-737-05	569	13-247-02	570	13-757-04	571	13-668-03	572
13-735-06	569	13-748-02	570	13-758-04	571	13-667-04	572
13-736-06	569	13-749-02	570	13-756-05	571	13-668-04	572
13-737-06	569	13-247-03	570	13-757-05	571	13-667-05	572
13-738-01	569	13-748-03	570	13-758-05	571	13-668-05	572
13-739-01	569	13-749-03	570	13-756-06	571	13-667-06	572
13-740-01	569	13-247-04	570	13-757-06	571	13-668-06	572
13-738-02	569	13-748-04	570	13-758-06	571	13-378-03	573
13-739-02	569	13-749-04	570	13-759-01	571	13-378-05	573
13-740-02	569	13-247-05	570	13-760-01	571	13-379-03	573
13-738-03	569	13-748-05	570	13-761-01	571	13-379-05	573
13-739-03	569	13-749-05	570	13-759-02	571	13-380-03	573
13-740-03	569	13-247-06	570	13-760-02	571	13-380-05	573
13-738-04	569	13-748-06	570	13-761-02	571	13-381-03	573
13-739-04	569	13-749-06	570	13-759-03	571	13-381-05	573
13-740-04	569	13-750-01	570	13-760-03	571	13-382-03	573
13-738-05	569	13-751-01	570	13-761-03	571	13-382-05	573
13-739-05	569	13-752-01	570	13-759-04	571	13-383-03	573
13-740-05	569	13-750-02	570	13-760-04	571	13-383-05	573
13-738-06	569	13-751-02	570	13-761-04	571	13-384-18	573
13-739-06	569	13-752-02	570	13-759-05	571	13-385-18	573
13-740-06	569	13-750-03	570	13-760-05	571	13-386-13	574
13-741-01	569	13-751-03	570	13-761-05	571	13-386-22	574
13-742-01	569	13-752-03	570	13-759-06	571	13-386-18	574
13-743-01	569	13-750-04	570	13-760-06	571	13-387-13	574
13-741-02	569	13-751-04	570	13-761-06	571	13-387-22	574
13-742-02	569	13-752-04	570	13-762-01	571	13-387-18	574
13-743-02	569	13-750-05	570	13-763-01	571	13-388-13	574
13-741-03	569	13-751-05	570	13-764-01	571	13-388-22	574
13-742-03	569	13-752-05	570	13-762-02	571	13-388-18	574
13-743-03	569	13-750-06	570	13-763-02	571	13-389-13	574
13-741-04	569	13-751-06	570	13-764-02	571	13-389-22	574
13-742-04	569	13-752-06	570	13-762-03	571	13-389-18	574
13-743-04	569	13-753-01	571	13-763-03	571	13-390-13	574
13-741-05	569	13-754-01	571	13-764-03	571	13-390-22	574
13-742-05	569	13-755-01	571	13-762-04	571	13-390-18	574
13-743-05	569	13-753-02	571	13-763-04	571	13-391-13	574
13-741-06	569	13-754-02	571	13-764-04	571	13-391-22	574
13-742-06	569	13-755-02	571	13-762-05	571	13-391-18	574
13-743-06	569	13-753-03	571	13-763-05	571	13-392-13	574
13-744-01	569	13-754-03	571	13-764-05	571	13-392-22	574
13-745-01	569	13-755-03	571	13-762-06	571	13-392-18	574
13-746-01	569	13-753-04	571	13-763-06	571	13-393-13	574
13-744-02	569	13-754-04	571	13-764-06	571	13-393-22	574
13-745-02	569	13-755-04	571	13-765-01	572	13-393-18	574
13-746-02	569	13-753-05	571	13-766-01	572	13-394-13	574
13-744-03	569	13-754-05	571	13-765-02	572	13-394-22	574
13-745-03	569	13-755-05	571	13-766-02	572	13-394-18	574
13-746-03	569	13-753-06	571	13-765-03	572	13-395-18	574

13-396-02	575
13-396-03	575
13-396-04	575
13-396-06	575
13-397-02	575
13-397-03	575
13-397-04	575
13-397-06	575
13-398-02	575
13-398-03	575
13-398-04	575
13-398-06	575
13-399-02	575
13-399-03	575
13-399-04	575
13-399-05	575
13-400-02	575
13-400-03	575
13-400-04	575
13-400-05	575
13-401-02	575
13-401-03	575
13-401-04	575
13-401-05	575
13-402-17	576
13-403-17	576
13-404-19	576
13-404-21	576
13-405-02	577
13-405-03	577
13-405-04	577
13-405-05	577
13-405-06	577
13-406-02	577
13-406-03	577
13-406-04	577
13-406-05	577
13-406-06	577
13-407-02	577
13-407-03	577
13-407-04	577
13-407-05	577
13-407-06	577
13-408-02	577
13-408-04	577
13-408-05	577
13-408-06	577
13-409-02	577
13-409-04	577
13-409-05	577
13-409-06	577
13-410-02	577
13-410-04	577
13-410-05	577
13-410-06	577
13-411-05	577
13-411-06	577
13-412-05	577
13-412-06	577
13-413-05	577
13-413-06	577

18-288-12	578
18-289-12	578
18-290-12	578
18-291-12	578
18-292-12	578
18-293-00	578
18-294-00	578
18-295-00	578
18-296-00	578
18-297-00	578
18-298-00	578
18-299-00	578
18-300-18	578
18-301-18	578
18-302-18	578
18-303-18	578
18-304-18	578
18-305-18	578
18-306-18	578
18-307-18	578
18-308-18	578
08-160-16	579
08-160-00	579
08-161-25	579
08-161-00	579
08-164-01	579
08-164-02	579
08-164-03	579
08-164-04	579
08-164-05	579
08-165-01	579
08-165-02	579
08-165-03	579
08-165-04	579
08-165-05	579
13-867-25	580
13-868-50	580
13-868-64	580
13-867-00	580
13-867-25	580
13-878-01	581
13-878-00	581
13-878-01	581
13-888-45	581
13-888-65	581
13-879-00	581
13-879-01	581
13-879-01	581
13-888-45	581
13-880-03	581
13-884-40	581
13-884-40	582
13-884-45	582
13-884-50	582
13-884-55	582
13-884-60	582
13-884-65	582
13-884-75	582
13-885-40	582
13-885-45	582
13-885-50	582

13-885-55	582
13-885-60	582
13-885-65	582
13-885-75	582
13-881-11	582
13-882-20	582
13-883-20	582
13-886-40	582
13-886-45	582
13-886-50	582
13-886-55	582
13-886-60	582
13-886-65	582
13-887-40	582
13-887-45	582
13-887-50	582
13-887-55	582
13-887-60	582
13-887-65	582
13-888-40	583
13-888-45	583
13-888-50	583
13-888-55	583
13-888-60	583
13-888-65	583
13-888-70	583
13-888-75	583
13-889-40	583
13-889-45	583
13-889-50	583
13-889-55	583
13-889-60	583
13-889-65	583
13-890-30	583
13-890-35	583
13-890-40	583
13-890-45	583
13-890-50	583
13-890-55	583
13-890-60	583
13-890-65	583
13-890-70	583
13-890-75	583
13-891-50	583
13-891-60	583
13-892-25	583
13-892-30	583
13-892-35	583
13-892-40	583
13-892-45	583
13-892-50	583
13-892-55	583
13-892-60	583
13-892-65	583
13-892-70	583
13-893-25	583
13-893-30	583
13-893-35	583
13-893-40	583
13-893-45	583
13-893-50	583

13-893-55	583
13-893-60	583
13-893-65	583
13-893-70	583
13-894-13	584
13-894-00	584
13-894-13	584
13-895-00	584
13-895-00	584
13-895-20	584
13-884-40	584
13-884-45	584
13-884-50	584
13-884-55	584
13-884-60	584
13-884-65	584
13-884-75	584
13-885-40	584
13-885-45	584
13-885-50	584
13-885-55	584
13-885-60	584
13-885-65	584
13-885-75	584
13-896-17	585
13-896-00	585
13-896-17	585
13-897-11	585
13-897-00	585
13-897-11	585
13-884-40	585
13-884-45	585
13-884-50	585
13-884-55	585
13-884-60	585
13-884-65	585
13-884-75	585
13-885-40	585
13-885-45	585
13-885-50	585
13-885-55	585
13-885-60	585
13-885-65	585
13-885-75	585
13-898-13	586
13-898-00	586
13-898-13	586
13-899-20	586
13-899-00	586
13-899-20	586
13-900-40	586
13-900-45	586
13-900-50	586
13-900-55	586
13-900-60	586
13-900-65	586
13-900-70	586
13-900-75	586
13-901-40	586
13-901-45	586
13-901-50	586

13-901-55	586	13-910-60	588	21-627-04	594	13-942-00	598
13-901-60	586	13-910-70	588	13-929-00	594	13-942-01	598
13-901-65	586	13-910-00	588	13-912-00	594	13-945-47	598
13-901-70	586	13-911-40	589	13-881-00	594	13-945-60	598
13-901-75	586	13-911-45	589	21-515-03	594	13-943-01	598
13-902-40	586	13-911-50	589	21-627-04	594	13-943-00	598
13-902-45	586	13-911-55	589	13-930-00	595	13-943-01	598
13-902-50	586	13-911-60	589	13-917-00	595	13-944-01	599
13-902-55	586	13-911-65	589	13-918-00	595	13-944-00	599
13-902-60	586	13-911-70	589	13-924-01	595	13-944-01	599
13-902-65	586	13-911-75	589	13-923-14	595	13-947-48	599
13-902-70	586	13-911-85	589	13-921-14	595	13-947-58	599
13-902-75	586	13-912-00	589	13-931-00	595	13-947-78	599
13-903-01	587	13-913-35	589	13-912-00	595	13-956-48	599
13-904-01	587	13-913-40	589	13-881-00	595	13-956-81	599
13-905-40	587	13-913-45	589	13-932-50	596	13-956-90	599
13-905-60	587	13-913-50	589	13-933-01	596	13-945-57	600
13-906-40	587	13-913-55	589	13-933-00	596	13-945-83	600
13-906-60	587	13-913-60	589	13-933-01	596	13-946-57	600
13-907-40	587	13-913-65	589	13-934-01	596	13-946-71	600
13-907-60	587	13-913-75	589	13-934-02	596	13-947-48	600
13-904-00	587	13-913-70	589	13-935-03	596	13-947-58	600
13-904-01	587	13-913-85	589	13-935-04	596	13-947-78	600
21-545-03	587	13-914-40	589	13-935-05	596	13-948-45	600
21-627-04	587	13-914-45	589	13-936-01	597	13-948-50	600
13-905-30	587	13-914-50	589	13-936-00	597	13-949-70	600
13-905-40	587	13-914-55	589	13-936-01	597	13-949-50	600
13-905-50	587	13-914-60	589	13-938-58	597	13-949-62	600
13-905-60	587	13-914-65	589	13-937-00	597	13-949-80	600
13-905-70	587	13-914-70	589	13-936-02	597	13-950-48	600
13-905-80	587	13-915-00	590	13-936-00	597	13-950-58	600
13-905-00	587	13-916-00	590	13-936-01	597	13-950-51	600
13-906-30	587	13-917-00	590	13-938-38	597	13-950-60	600
13-906-40	587	13-918-00	590	13-937-00	597	13-950-65	600
13-906-50	587	13-919-00	591	13-938-38	597	13-950-74	600
13-906-60	587	13-920-00	591	13-938-58	597	13-951-74	600
13-906-70	587	13-921-12	591	13-939-32	597	13-951-78	600
13-906-80	587	13-921-14	591	13-939-37	597	13-951-80	600
13-906-00	587	13-921-16	591	13-939-42	597	13-951-89	600
13-907-20	588	13-921-18	591	13-939-47	597	13-951-90	600
13-907-30	588	13-922-12	591	13-939-52	597	13-951-10	600
13-907-40	588	13-922-14	591	13-939-57	597	13-952-10	600
13-907-50	588	13-922-16	591	13-939-65	597	13-953-60	600
13-907-60	588	13-923-14	591	13-939-67	597	13-953-78	600
13-907-70	588	13-924-01	592	13-940-32	597	13-954-78	600
13-907-00	588	13-924-02	592	13-940-37	597	13-954-91	600
13-908-20	588	13-925-01	592	13-940-42	597	13-955-70	600
13-908-30	588	13-925-02	592	13-940-47	597	13-956-48	600
13-908-40	588	13-926-01	592	13-940-52	597	13-956-62	600
13-908-50	588	13-926-02	592	13-940-57	597	13-956-70	600
13-908-60	588	13-927-00	593	13-940-65	597	13-956-81	600
13-908-70	588	13-878-01	593	13-940-67	597	13-956-78	600
13-908-00	588	13-879-02	593	13-941-32	597	13-956-90	600
13-909-30	588	13-880-03	593	13-941-37	597	13-957-01	601
13-909-40	588	13-881-00	593	13-941-42	597	13-957-00	601
13-909-50	588	21-545-03	593	13-941-47	597	13-957-01	601
13-909-60	588	21-627-04	593	13-941-52	597	13-959-60	601
13-909-70	588	13-928-00	594	13-941-57	597	13-959-58	601
13-909-80	588	13-912-00	594	13-941-65	597	13-960-48	601
13-909-00	588	13-881-00	594	13-941-67	597	13-958-48	601
13-910-50	588	21-515-03	594	13-942-01	598	13-958-62	601

13-958-70	601
13-958-81	601
13-958-78	601
13-958-90	601
13-959-60	601
13-959-78	601
13-959-78	601
13-959-91	601
13-961-80	602
13-961-10	602
13-962-60	602
13-962-70	602
13-963-57	602
13-963-77	602
13-964-57	602
13-964-83	602
13-965-48	602
13-965-58	602
13-965-78	602
13-966-50	602
13-966-45	602
13-967-50	602
13-967-62	602
13-967-70	602
13-967-80	602
13-968-48	602
13-968-65	602
13-969-80	602
13-968-58	602
13-968-74	602
13-969-89	602
13-968-51	602
13-969-74	602
13-969-90	602
13-968-60	602
13-969-78	602
13-969-10	602
13-970-10	602

## 14

Thorax – Lung  
Thorax – Lunge  
Tórax – Pulmón  
Thorax – Poumon  
Torace – Polmone

14-904-24	604
14-905-01	604
14-905-02	604
14-906-36	604
14-907-26	604
14-908-27	604
14-909-34	604
14-910-08	605
14-911-10	605
14-912-12	605
14-913-00	605
14-914-00	606
14-915-00	606
14-915-01	606
14-916-00	606

14-916-01	606
14-917-00	606
14-917-01	606
14-918-00	606
14-918-01	606
14-919-00	607
14-920-00	607
14-921-00	607
14-922-00	607
14-923-00	608
14-924-00	608
14-825-00	608
14-926-00	609
14-927-00	609
14-928-00	609
14-929-00	610
14-930-00	610
14-931-00	610
14-932-00	610
14-933-00	610
14-934-00	611
14-935-00	611
14-935-01	611
14-936-00	612
14-937-00	612
14-937-01	612
14-937-02	612
14-938-00	613
14-939-0	613
14-940-00	613
14-941-00	614
14-942-00	614
14-943-00	614
14-943-01	614
14-943-02	614
14-944-00	615
14-945-01	615
14-945-02	615
14-946-00	615
14-947-30	616
14-947-32	616
14-948-14	616
14-949-16	616
14-950-14	617
14-950-18	617
14-951-16	617
14-952-19	618

## 15

Stomach – Intestine  
Magen – Darm  
Estómago – Intestino  
Estomac – Intestin  
Stomaco – Intestino

15-200-13	620
15-201-15	620
15-201-19	620
15-201-25	620
15-202-15	620
15-202-19	620

15-202-25	620
15-203-15	620
15-204-20	620
15-205-20	620
15-206-16	620
15-207-19	621
15-208-15	621
15-209-15	621
15-209-19	621
15-210-16T	621
15-211-20T	621
15-212-20T	621
15-213-16	621
15-213-18	621
15-213-20	621
15-213-24	621
15-214-18	622
15-214-20	622
15-214-23	622
15-215-18	622
15-215-20	622
15-215-23	622
15-216-16	622
15-217-20	622
15-218-23	622
15-220-16	622
15-221-20	622
15-222-25	622
15-223-22	623
15-224-25	623
15-225-28	623
15-226-22	623
15-227-25	623
15-228-28	623
15-229-15	624
15-230-13	624
15-231-13	624
15-232-18	624
15-233-18	624
15-234-21	624
15-234-23	624
15-234-28	624
15-235-21	624
15-235-23	624
15-235-28	624
15-236-24	625
15-237-25	625
15-238-25	625
15-239-30	626
15-240-30	626
15-241-14	627
15-242-16	627
15-243-18	627
15-244-21	627
15-245-23	627
15-246-14	627
15-247-16	627
15-248-18	627
15-249-21	627
15-250-23	627
15-251-25	628

15-252-25	628
15-259-30	628
15-253-22	629
15-254-25	629
15-255-28	629
15-256-22	629
15-257-25	629
15-258-28	629
15-260-26	630
15-261-28	630
15-262-24	630
15-263-24	631
15-264-25	632
15-265-26	632
15-266-18	632
15-267-20	632
15-268-23	632
15-269-15	633
15-270-21	633
15-271-29	633
15-272-08	634
15-273-23	634
15-274-26	634
15-275-05	634
15-276-07	634
15-277-10	634
15-278-00	635
15-279-00	635
15-280-19	635
15-281-20	636
15-282-22	636
15-283-09	637
15-284-01	637
15-284-02	637
15-285-01	637
15-285-02	637
15-286-06	638
15-286-01	638
15-286-02	638
15-287-01	638
15-287-02	638
15-287-03	638
15-287-04	638
15-288-00	638
15-289-15	638
15-290-00	639
15-291-14	639
15-292-02	639
15-293-02	639
15-294-02	639
15-295-02	639
15-296-00	640
15-297-00	640
15-298-23	641
15-298-33	641
15-298-40	641
15-299-23	641
15-299-33	641
15-299-40	641
15-300-23	641
15-300-33	641

15-300-40	641
15-301-23	641
15-301-33	641
15-301-40	641
15-302-28	641
15-303-28	641
15-304-28	641
15-305-28	641
15-302-35	641
15-303-35	641
15-304-35	641
15-305-35	641
15-302-42	641
15-303-42	641
15-304-42	641
15-305-42	641
15-330-24	642
15-331-00	642
15-332-19	642
15-333-20	643
15-324-21	643
15-335-08	644
15-335-10	644
15-336-10	644
15-337-00	644
15-338-31	644
15-339-31	644
15-340-00	644

## 16

Urology	
Urologie	
Urología	
Urologie	
Urologia	
16-400-23	646
16-401-22	646
16-402-19	646
16-403-19	646
16-404-19	646
16-405-19	646
16-406-30	647
16-407-30	647
16-408-30	647
16-409-30	647
16-410-30	647
16-411-30	647
16-412-30	647
16-413-30	647
16-414-30	647
16-415-30	647
16-416-30	647
16-417-30	647
16-418-30	647
16-406-00	647
16-419-28	647
16-420-28	647
16-421-28	647
16-422-30	648
16-423-30	648

16-424-30	648
16-425-30	648
16-426-34	648
16-427-32	649
16-428-32	649
16-429-32	649
16-430-32	649
16-431-32	649
16-432-32	649
16-433-32	649
16-434-32	649
16-435-28	649
16-436-21	649
16-437-22	649
16-438-23	649
16-439-20	650
16-440-20	650
16-441-23	650
16-442-23	650
16-443-24	650
16-444-18	650
16-445-19	650
16-446-21	651
16-447-22	651
16-448-24	651
16-449-22	651
16-450-23	652
16-451-23	652
16-452-23	652
16-453-24	652
16-454-20	652
16-455-00	653
16-456-01	653
16-457-02	653
16-458-03	653
16-459-04	653
16-460-05	653
16-461-00	653
16-462-00	653
16-463-00	654
16-464-00	654
16-465-27	654
16-466-26	654
16-467-28	654
16-468-01	655
16-468-02	655
16-468-03	655
16-468-04	655
16-468-05	655
16-468-06	655
16-468-07	655
16-468-08	655
16-468-09	655
16-468-10	655
16-468-11	655
16-468-12	655
16-468-13	655
16-468-14	655
16-468-15	655
16-468-16	655
16-468-17	655

16-468-18	655
16-468-19	655
16-468-20	655
16-468-21	655
16-468-22	655
16-468-23	655
16-468-24	655
16-468-25	655
16-468-26	655
16-468-27	655
16-469-01	655
16-469-02	655
16-469-03	655
16-469-04	655
16-469-05	655
16-469-06	655
16-469-07	655
16-469-08	655
16-469-09	655
16-469-10	655
16-469-11	655
16-469-12	655
16-469-13	655
16-469-14	655
16-469-15	655
16-469-16	655
16-469-17	655
16-469-18	655
16-469-19	655
16-469-20	655
16-469-21	655
16-469-22	655
16-469-23	655
16-469-24	655
16-469-25	655
16-469-26	655
16-469-27	655
16-470-00	656
16-471-00	657
16-472-00	657
16-473-20	658
16-473-28	658
16-474-16	658
16-475-39	658
16-476-35	658
16-477-14	658
16-478-01	659
16-478-02	659
16-478-03	659
16-478-04	659
16-478-05	659
16-478-06	659
16-478-07	659
16-479-07	659
16-480-00	660
16-481-00	660

## 17

Gynecology	
Gynäkologie	
Ginecología	
Gynécologie	
Ginecologia	
17-601-01	662
17-601-02	662
17-601-03	662
17-601-04	662
17-602-01	662
17-602-02	662
17-602-03	662
17-602-04	662
17-602-05	662
17-602-06	662
17-603-01	662
17-603-02	662
17-603-03	662
17-603-04	662
17-603-05	662
17-604-01	662
17-604-02	662
17-604-03	662
17-605-01	663
17-605-02	663
17-605-03	663
17-606-01	663
17-606-02	663
17-606-03	663
17-607-01	663
17-607-02	663
17-607-03	663
17-608-01	663
17-608-02	663
17-608-03	663
17-609-01	664
17-609-02	664
17-609-03	664
17-609-04	664
17-609-05	664
17-609-06	664
17-610-01	664
17-610-02	664
17-610-03	664
17-610-04	664
17-610-05	664
17-610-06	664
17-611-01	664
17-611-02	664
17-611-03	664
17-611-04	664
17-611-05	664
17-611-06	664
17-612-01	665
17-612-02	665
17-613-01	665
17-613-02	665
17-614-01	665
17-614-02	665

17-615-01	665	17-634-11	668	17-657-03	673	17-670-18	677
17-615-02	665	17-635-24	669	17-657-04	673	17-671-24	677
17-615-03	665	17-636-24	669	17-657-05	673	17-672-25	677
17-615-04	665	17-637-01	669	17-657-06	673	17-673-25	677
17-615-05	665	17-637-02	669	17-657-07	673	17-674-24	677
17-615-06	665	17-638-01	670	17-657-08	673	17-675-24	678
17-616-22	665	17-638-02	670	17-657-09	673	17-676-24	678
17-617-01	666	17-638-03	670	17-657-10	673	17-677-28	678
17-617-02	666	17-638-04	670	17-657-11	673	17-678-26	679
17-617-03	666	17-639-01	670	17-657-12	673	17-679-26	679
17-617-00	666	17-639-02	670	17-657-13	673	17-680-01	679
17-618-01	666	17-639-03	670	17-657-14	673	17-680-02	679
17-618-02	666	17-639-04	670	17-657-15	673	17-680-03	679
17-619-01	666	17-640-01	670	17-657-16	673	17-681-01	679
17-619-02	666	17-640-02	670	17-657-17	673	17-681-02	679
17-620-01	666	17-640-03	670	17-657-18	673	17-681-03	679
17-620-02	666	17-640-04	670	17-657-19	673	17-682-01	680
17-621-01	667	17-641-01	670	17-657-20	673	17-683-21	680
17-621-02	667	17-641-02	670	17-658-01	673	17-684-21	680
17-622-01	667	17-641-03	670	17-658-02	673	17-685-26	680
17-622-02	667	17-641-04	670	17-658-03	673	17-674-21	680
17-622-03	667	17-642-01	670	17-658-04	673	17-687-32	681
17-622-04	667	17-642-02	670	17-658-05	673	17-688-27	681
17-622-05	667	17-642-03	670	17-658-06	673	17-689-20	681
17-623-01	667	17-642-04	670	17-658-07	673	17-690-27	682
17-623-02	667	17-643-22	671	17-658-08	673	17-691-23	682
17-623-03	667	17-644-21	671	17-658-09	673	17-692-25	682
17-623-04	667	17-645-21	671	17-658-10	673	17-693-23	683
17-623-05	667	17-646-20	671	17-658-11	673	17-694-27	683
17-624-01	667	17-647-25	671	17-659-01	673	17-695-17	683
17-624-02	667	17-648-25	671	17-659-02	673	17-409-19	683
17-625-01	668	17-649-24	671	17-660-01	674	17-696-22	684
17-626-02	668	17-650-23	671	17-660-02	674	17-697-22	684
17-627-03	668	17-651-25	672	17-661-01	675	17-698-22	684
17-628-04	668	17-363-29	672	17-661-02	675	17-699-22	684
17-629-05	668	17-652-32	672	17-661-03	675	17-700-22	684
17-630-00	668	17-653-32	672	17-661-04	675	17-701-22	684
17-631-01	668	17-654-32	672	17-661-05	675	17-702-22	684
17-631-02	668	17-655-32	672	17-661-06	675	17-703-21	685
17-632-00	668	17-191-09	673	17-661-07	675	17-703-28	685
17-633-01	668	17-407-32	673	17-661-08	675	17-704-21	685
17-633-02	668	17-656-01	673	17-661-09	675	17-705-26	685
17-633-03	668	17-656-02	673	17-661-10	675	17-706-23	686
17-633-04	668	17-656-03	673	17-661-11	675	17-707-22	686
17-633-05	668	17-656-04	673	17-661-12	675	17-707-24	686
17-633-06	668	17-656-05	673	17-661-13	675	17-708-28	687
17-633-07	668	17-656-06	673	17-662-01	675	17-709-23	687
17-633-08	668	17-656-07	673	17-662-02	675	17-710-23	687
17-633-09	668	17-656-08	673	17-663-01	675	17-711-23	687
17-633-10	668	17-656-09	673	17-664-01	675	17-712-23	687
17-633-11	668	17-656-10	673	17-664-02	675	17-713-24	688
17-634-01	668	17-656-11	673	17-665-01	676	17-714-24	688
17-634-02	668	17-656-12	673	17-665-02	676	17-715-24	688
17-634-03	668	17-656-13	673	17-665-03	676	17-716-24	688
17-634-04	668	17-656-14	673	17-665-04	676	17-717-24	688
17-634-05	668	17-656-15	673	17-665-05	676	17-718-20	689
17-634-06	668	17-656-16	673	17-665-06	676	17-719-20	689
17-634-07	668	17-656-17	673	17-666-01	676	17-720-24	689
17-634-08	668	17-656-18	673	17-667-01	676	17-721-20	690
17-634-09	668	17-657-01	673	17-668-28	676	17-721-25	690
17-634-10	668	17-657-02	673	17-669-17	677	17-722-01	690

17-722-02	690	17-748-07	695	17-752-12	695	17-761-03	697
17-723-20	690	17-748-08	695	17-752-13	695	17-761-04	697
17-723-25	690	17-748-09	695	17-752-14	695	17-761-05	697
17-724-01	690	17-748-10	695	17-753-01	695	17-761-06	697
17-724-02	690	17-748-11	695	17-753-02	695	17-762-01	697
17-725-00	691	17-748-12	695	17-753-03	695	17-762-02	697
17-726-00	691	17-748-13	695	17-753-04	695	17-762-03	697
17-727-00	691	17-748-14	695	17-753-05	695	17-762-04	697
17-728-00	691	17-749-01	695	17-753-06	695	17-762-05	697
17-729-00	691	17-749-02	695	17-753-07	695	17-762-06	697
17-730-00	691	17-749-03	695	17-753-08	695	17-763-25	698
17-731-00	691	17-749-04	695	17-753-09	695	17-764-25	698
17-732-00	691	17-749-05	695	17-753-10	695	17-765-25	698
17-733-00	691	17-749-06	695	17-753-11	695	17-766-00	698
17-734-00	691	17-749-07	695	17-753-12	695	17-767-00	698
17-735-00	691	17-749-08	695	17-753-13	695	17-768-00	698
17-736-24	692	17-749-09	695	17-753-14	695	17-769-30	698
17-737-30	692	17-749-10	695	17-754-01	695	17-770-30	698
17-738-30	692	17-749-11	695	17-754-02	695	17-771-30	698
17-739-00	692	17-749-12	695	17-754-03	695	17-772-00	698
17-740-00	692	17-749-13	695	17-754-04	695	17-773-00	698
17-741-23	692	17-749-14	695	17-754-05	695	17-774-00	698
17-742-01	692	17-750-01	695	17-754-06	695	17-775-30	699
17-742-02	692	17-750-02	695	17-754-07	695	17-776-33	699
17-742-03	692	17-750-03	695	17-754-08	695	17-776-36	699
17-743-01	693	17-750-04	695	17-754-09	695	17-777-36	699
17-723-02	693	17-750-05	695	17-754-10	695	17-777-40	699
17-743-03	693	17-750-06	695	17-754-11	695	17-778-44	699
17-743-04	693	17-750-07	695	17-754-12	695	17-779-36	700
17-743-05	693	17-750-08	695	17-754-13	695	17-780-25	700
17-743-06	693	17-750-09	695	17-754-14	695	17-780-28	700
17-743-07	693	17-750-10	695	17-755-01	696	17-781-30	700
17-744-12	693	17-750-11	695	17-755-02	696	17-782-36	700
17-730-04	693	17-750-12	695	17-755-03	696	17-782-39	700
17-730-06	693	17-750-13	695	17-755-04	696	17-783-32	701
17-730-08	693	17-750-14	695	17-756-01	696	17-783-38	701
17-730-10	693	17-751-01	695	17-756-02	696	17-784-36	701
17-730-12	693	17-751-02	695	17-756-03	696	17-785-41	701
17-730-14	693	17-751-03	695	17-756-04	696	17-786-40	701
17-745-29	694	17-751-04	695	17-757-01	696	17-787-00	701
17-746-23	694	17-751-05	695	17-757-02	696	17-788-28	702
17-747-01	695	17-751-06	695	17-757-03	696	17-789-32	702
17-747-02	695	17-751-07	695	17-757-04	696	17-790-21	702
17-747-03	695	17-751-08	695	17-758-01	696	17-790-00	702
17-747-04	695	17-751-09	695	17-758-02	696	17-791-25	703
17-747-05	695	17-751-10	695	17-758-03	696	17-792-42	703
17-747-06	695	17-751-11	695	17-758-04	696	17-793-46	703
17-747-07	695	17-751-12	695	17-759-01	697	17-794-28	704
17-747-08	695	17-751-13	695	17-759-02	697	17-795-28	704
17-747-09	695	17-751-14	695	17-759-03	697	17-796-28	704
17-747-10	695	17-752-01	695	17-759-04	697	17-797-00	704
17-747-11	695	17-752-02	695	17-759-05	697	17-798-00	704
17-747-12	695	17-752-03	695	17-759-06	697	17-799-00	704
17-747-13	695	17-752-04	695	17-760-01	697	17-800-30	704
17-747-14	695	17-752-05	695	17-760-02	697	17-801-30	704
17-748-01	695	17-752-06	695	17-760-03	697	17-802-30	704
17-748-02	695	17-752-07	695	17-760-04	697	17-803-27	705
17-748-03	695	17-752-08	695	17-760-05	697	17-804-27	705
17-748-04	695	17-752-09	695	17-760-06	697	17-805-27	705
17-748-05	695	17-752-10	695	17-761-01	697	17-806-30	705
17-748-06	695	17-752-11	695	17-761-02	697	17-807-08	706



17-808-09	706
17-811-01	706
17-811-02	706
17-811-03	706
17-809-34	706
17-810-35	706

## 18

ENT  
 HNO  
 ORL  
 ORL  
 ORL

18-801-00	708
18-801-03	708
18-802-03	708
18-803-03	708
18-804-03	708
18-805-00	708
18-806-01	708
18-807-02	708
18-808-03	708
18-809-00	709
18-809-01	709
18-810-02	709
18-811-03	709
18-812-04	709
18-813-00	709
18-813-01	709
18-814-02	709
18-815-03	709
18-816-04	709
18-817-00	709
18-817-01	709
18-818-02	709
18-819-03	709
18-820-04	709
18-821-05	709
18-822-06	709
18-823-00	709
18-823-01	709
18-824-02	709
18-825-03	709
18-826-04	709
18-827-00	710
18-827-01	710
18-828-02	710
18-829-03	710
18-830-04	710
18-831-00	710
18-832-01	710
18-833-02	710
18-834-00	710
18-834-01	710
18-835-02	710
18-836-03	710
18-837-04	710
18-838-00	710
18-838-01	710
18-839-02	710

18-840-03	710
18-841-04	710
18-842-05	710
18-127-08	710
18-127-01	710
18-128-02	710
18-127-03	710
18-127-04	710
18-127-05	710
18-127-06	710
18-127-00	710
18-843-00	711
18-844-01	711
18-845-02	711
18-846-00	711
18-847-00	711
18-848-01	711
18-849-02	711
18-850-01	711
18-851-00	711
18-852-00	712
18-853-00	712
18-854-00	712
18-855-00	712
18-856-00	713
18-857-00	713
18-858-00	713
18-859-00	713
18-860-00	713
18-861-00	714
18-862-00	714
18-863-00	714
18-864-00	714
18-865-00	714
18-866-00	714
18-867-00	714
18-867-00	714
18-857-00	714
18-858-00	714
18-863-00	714
18-864-00	714
18-865-00	714
18-868-00	715
18-869-00	715
18-870-00	715
18-871-00	715
18-872-00	715
18-873-00	715
18-873-00	715
18-868-00	715
18-869-00	715
18-870-00	715
18-871-00	715
18-872-00	715
18-874-16	716
18-875-16	716
18-876-16	716
18-877-16	716
18-878-16	716
18-879-16	716
18-880-16	716

18-881-16	716
18-882-16	716
18-883-16	716
18-884-16	716
18-885-16	716
18-886-16	716
18-887-16	716
18-888-16	716
18-889-16	716
18-890-16	717
18-891-16	717
18-892-16	717
18-893-16	717
18-894-16	717
18-895-16	717
18-896-16	717
18-897-16	717
18-898-16	717
18-899-16	717
18-900-16	717
18-901-16	717
18-902-16	717
18-903-16	717
18-904-16	717
18-905-16	717
18-906-13	718
18-907-17	718
18-908-12	718
18-909-12	718
18-910-16	718
18-911-16	719
18-912-16	719
18-913-16	719
18-914-14	719
18-915-14	719
18-916-14	719
18-917-14	719
18-918-14	719
18-919-14	719
18-920-14	719
18-921-14	719
18-922-14	719
18-923-14	719
18-924-16	720
18-925-16	720
18-926-13	720
18-927-17	720
18-928-16	721
18-929-16	721
18-930-16	721
18-931-18	721
18-932-18	721
18-933-19	721
18-934-17	721
18-935-16	721
18-936-16	721
18-942-12	722
18-943-12	722
18-944-14	722
18-945-10	722
18-946-11	722

18-947-08	723
18-948-08	723
18-949-01	723
18-949-02	723
18-949-03	723
18-950-08	723
18-950-14	723
18-951-09	723
18-952-08	723
18-953-08	723
18-954-08	723
18-955-08	723
18-956-01	723
18-956-02	723
18-956-03	723
18-957-00	724
18-958-08	724
18-959-08	724
18-960-08	724
18-961-08	724
18-962-08	724
18-963-07	725
18-964-07	725
18-965-07	725
18-966-07	725
18-967-01	725
18-967-02	725
18-967-03	725
18-967-04	725
18-967-05	725
18-967-06	725
18-967-07	725
18-967-08	725
18-968-07	726
18-969-07	726
18-970-07	726
18-971-07	726
18-972-07	726
18-973-01	727
18-973-02	727
18-974-01	727
18-974-02	727
18-975-01	727
18-975-02	727
18-976-01	727
18-976-02	727
18-977-07	728
18-978-07	728
18-979-07	728
18-980-07	728
18-981-07	728
18-982-08	729
18-983-08	729
18-984-08	729
18-985-08	729
18-986-16	730
18-987-16	730
18-988-16	730
18-989-00	730
18-990-00	730
18-991-00	730

18-992-16	730	18-137-03	735	18-212-07	743	18-271-18	749
18-993-16	730	18-138-01	735	18-328-00	743	18-272-18	749
18-994-01	730	18-138-02	735	18-328-01	743	18-273-18	749
18-994-02	730	18-138-03	735	18-328-02	743	18-274-00	749
18-994-03	730	18-139-01	735	18-328-03	743	18-275-20	750
18-994-05	730	18-139-02	735	18-328-04	743	18-281-19	750
18-995-16	731	18-139-03	735	18-328-05	743	18-282-19	750
18-996-16	731	18-140-01	735	18-328-06	743	18-283-19	750
18-997-16	731	18-140-02	735	18-328-07	743	18-284-19	750
18-998-16	731	18-140-03	735	18-329-00	743	18-285-12	750
18-999-16	731	18-141-15	735	18-329-01	743	18-286-12	750
18-100-16	731	18-142-16	735	18-329-02	743	18-287-12	750
18-101-00	731	18-143-01	735	18-329-03	743	18-288-12	751
18-102-00	731	18-143-02	735	18-329-04	743	18-289-12	751
18-103-16	731	18-143-03	735	18-329-05	743	18-290-12	751
18-104-01	731	18-144-01	735	18-329-06	743	18-291-12	751
18-104-02	731	18-144-02	735	18-329-07	743	18-292-12	751
18-104-03	731	18-144-03	735	18-236-00	743	18-293-00	751
18-104-04	731	18-145-01	735	18-237-06	743	18-294-00	751
18-104-05	731	18-145-02	735	18-238-06	743	18-295-00	751
18-105-16	731	18-145-03	735	18-236-00	743	18-296-00	751
18-106-16	731	18-146-01	735	18-239-16	744	18-297-00	751
18-107-00	732	18-146-02	735	18-240-16	744	18-298-00	751
18-108-00	732	18-146-03	735	18-241-16	744	18-299-00	751
18-109-00	732	18-147-15	736	18-242-15	744	18-300-18	751
18-110-00	732	18-148-15	736	18-243-15	744	18-301-18	751
18-111-00	732	18-149-15	736	18-244-15	744	18-302-18	751
18-112-00	732	18-150-15	736	18-245-13	744	18-303-18	751
18-113-00	732	18-151-00	736	18-246-14	744	18-304-18	751
18-114-00	732	18-152-17	737	18-247-13	745	18-305-18	751
18-115-00	732	18-153-17	737	18-248-13	745	18-306-18	751
18-116-00	733	18-154-16	737	18-249-13	745	18-307-18	751
18-117-00	733	18-155-00	737	18-250-13	745	18-308-18	751
18-118-00	733	18-156-15	738	18-251-15	745	18-309-12	751
18-119-00	733	18-157-15	738	18-252-15	745	18-310-12	751
18-120-00	733	18-158-15	738	18-253-15	745	18-311-12	751
18-121-00	733	18-159-15	738	18-254-14	745	18-312-12	751
18-122-00	733	18-160-15	738	18-255-14	745	18-313-12	751
18-123-00	733	18-161-15	738	18-256-14	745	18-314-12	751
18-124-00	733	18-162-01	739	18-257-15	746	18-315-12	751
18-125-16	734	18-163-02	739	18-258-15	746	18-335-10	752
18-126-16	734	18-164-03	739	18-259-15	746	18-326-10	752
18-127-16	734	18-165-04	739	18-260-15	746	18-327-10	752
18-128-01	734	18-166-05	739	18-261-14	746	18-328-10	752
18-128-02	734	18-167-00	739	18-262-14	746	18-329-10	752
18-128-03	734	18-168-19	739	18-263-20	747	18-330-10	752
18-128-04	734	18-169-19	739	18-264-20	747	18-331-10	752
18-129-01	734	18-170-16	740	18-265-16	747	18-332-10	752
18-129-02	734	18-171-16	740	18-265-20	747	18-333-10	752
18-129-03	734	18-172-17	740	18-266-14	747	18-334-10	752
18-129-04	734	18-173-17	740	18-267-18	747	18-335-10	752
18-130-01	734	18-174-16	740	18-268-18	747	18-336-10	753
18-130-02	734	18-175-17	741	18-269-18	748	18-337-10	753
18-131-16	734	18-176-17	741	18-275-20	748	18-338-10	753
18-132-00	734	18-177-17	741	18-276-20	748	18-339-10	753
18-133-00	734	18-178-20	741	18-277-01	748	18-340-10	753
18-134-00	734	18-179-20	741	18-278-02	748	18-341-10	753
18-135-00	734	18-180-20	741	18-279-12	748	18-342-01	754
18-136-00	734	18-181-20	741	18-280-12	748	18-342-02	754
18-137-01	735	18-182-14	742	18-269-18	749	18-343-01	754
18-137-02	735	18-183-19	742	18-270-18	749	18-343-02	754

18-344-01	754
18-345-02	754
18-346-03	754
18-347-14	755
18-348-14	755
18-349-14	755
18-350-14	755
18-351-18	755
18-352-20	756
18-353-20	756
18-354-20	756
18-355-20	756
18-356-00	757
18-357-26	757
18-358-26	757
18-359-24	757
18-360-16	758
18-361-16	758
18-362-16	758
18-363-16	758
18-364-16	758
18-365-14	758
18-366-15	758
18-367-17	758
18-368-16	758
18-369-00	758
18-370-19	759
18-371-19	759
18-372-16	759
18-373-15	759
18-374-15	759
18-375-15	759
18-376-21	760
18-377-21	760
18-378-20	760
18-379-23	760
18-380-22	760
18-381-23	760
18-383-20	761
18-384-20	761
18-385-20	761
18-386-21	761
18-387-21	761
18-388-20	761
18-389-17	761
18-390-17	761
18-391-17	761
18-392-17	761
18-393-17	761
18-389-00	761
18-394-17	761
18-395-20	762
18-396-18	762
18-397-16	762
18-398-19	762
18-399-00	762
18-400-20	762
18-401-16	762
18-402-15	763
18-403-15	763
18-404-23	763

18-405-20	763
18-406-18	763
18-407-23	764
18-408-19	764
18-409-18	764
18-410-20	764
18-411-21	764
18-412-21	764
18-413-20	765
18-414-19	765
18-414-22	765
18-415-22	765
18-416-21	765
18-417-19	766
18-418-17	766
18-421-19	767
18-422-19	767
18-423-19	767
18-424-17	767
18-425-17	767
18-426-21	768
18-427-17	768
18-428-17	768
18-429-21	768
18-430-21	768
18-431-17	769
18-432-18	769
18-433-18	769
18-434-16	769
18-435-16	769
18-436-16	769
18-437-21	769
18-438-01T	770
18-439-03T	770
18-440-05T	770
18-441-07T	770
18-442-09T	770
18-448-19	771
18-449-01	771
18-449-02	771
18-449-03	771
18-450-12	771
18-451-00	771
18-452-00	771
18-453-23	772
18-454-23	772
18-455-23	772
18-456-23	772
18-457-19	773
18-458-19	773
18-459-20	773
18-460-20	773
18-461-00	773
18-462-21	774
18-463-21	774
18-464-21	774
18-465-21	774
18-466-22	774
18-467-22	774
18-468-22	774
18-469-22	774

18-470-22	775
18-471-22	775
18-472-22	775
18-473-22	775
18-474-22	775
18-475-22	775
18-476-22	775
18-477-22	775
18-478-22	775
18-479-22	775
18-480-22	775
18-481-22	775
18-482-25	776
18-483-25	776
18-484-25	776
18-485-25	776
18-486-25	776
18-487-25	776
18-488-00	776
18-489-00	776
18-490-00	776
18-491-00	776
18-492-00	776
18-493-00	776
18-494-01	776
18-494-02	776
18-494-03	776
18-495-01	776
18-495-02	776
18-495-03	776
18-496-00	777
18-497-00	777
18-498-00	777
18-499-08	777
18-499-11	777
18-500-13	777
18-501-00	777
18-502-00	778
18-503-00	778
18-504-00	778
18-505-00	778
18-503-00	778
18-504-00	778
18-505-00	778
18-506-00	778
18-507-00	778
18-508-11	779
18-508-13	779
18-508-15	779
18-509-09	779
18-509-11	779
18-509-13	779
18-509-15	779
18-510-10	779
18-511-13	779
18-512-11	780
18-513-14	780
18-514-12	780
18-515-14	780
18-516-16	780
18-516-19	780

18-517-14	781
18-518-00	781
18-519-00	781
18-520-00	781
18-521-01	782
18-522-02	782
18-523-03	782
18-524-00	782
18-525-00	782
18-526-01	782
18-527-02	782
18-528-03	782
18-529-00	782
18-530-00	782
18-531-01	783
18-532-02	783
18-533-03	783
18-534-04	783
18-535-05	783
18-536-00	783
18-537-00	783
18-538-01	783
18-539-02	783
18-540-03	783
18-541-00	783
18-542-00	783
18-543-00	784
18-543-12	784
18-543-01	784
18-543-02	784
18-543-03	784
18-543-04	784
18-543-05	784
18-543-06	784
18-543-07	784
18-543-08	784
18-543-09	784
18-543-10	784
18-544-10	784
18-545-11	784
18-545-12	784
18-545-01	784
18-545-02	784
18-545-03	784
18-545-04	784
18-545-05	784
18-545-06	784
18-545-07	784
18-545-08	784
18-545-09	784
18-545-10	784
18-446-01	784
18-446-02	784
18-446-03	784
18-446-04	784
18-446-05	784
18-547-23	785
18-548-20	785
18-549-28	786
18-550-28	786
18-551-28	786

18-552-28	786
18-553-01	786
18-553-02	786
18-554-01	786
18-554-02	786
18-455-00	787
18-456-00	787
18-557-25	788
18-558-18	788
18-559-23	788
18-560-23	788
18-561-22	789
18-656-21	789
18-562-19	789
18-563-22	789
18-564-20	789
18-565-19	790
18-466-19	790
18-567-18	790
18-567-23	790
18-568-20	790
18-569-22	790
18-570-01	791
18-571-02	791
18-572-03	791
18-573-00	791
18-574-00	791
18-575-12	791
18-576-12	791
18-577-12	791
18-578-14	792
18-579-14	792
18-580-00	793
18-580-01	793
18-580-02	793
18-580-03	793
18-580-04	793
18-580-05	793
18-580-06	793
18-580-07	793
18-580-08	793
18-580-09	793
18-581-22	793
18-582-00	793
18-582-01	793
18-582-02	793
18-582-03	793
18-582-04	793
18-582-05	793
18-582-06	793
18-582-07	793
18-582-08	793
18-582-09	793
18-583-17	794
18-584-15	794
18-584-20	794
18-585-15	794
18-585-16	794
18-586-15	794
18-586-16	794
18-587-20	795

18-587-30	795
18-587-40	795
18-587-50	795
18-587-60	795
18-588-20	795
18-589-00	795
18-590-00	795
18-591-00	795
18-592-00	795
18-593-00	795
18-594-00	795
18-595-00	795
18-596-00	795
18-597-01	795
18-598-01	795
18-599-02	795
18-600-02	795
18-601-00	795
18-602-00	795
18-603-00	795
18-675-30	796
18-675-40	796
18-675-50	796
18-675-60	796
18-676-30	796
18-676-40	796
18-676-50	796
18-676-60	796
18-677-30	796
18-677-40	796
18-677-50	796
18-677-60	796
18-678-30	796
18-678-40	796
18-678-50	796
18-678-60	796
18-604-30	796
18-604-40	796
18-604-50	796
18-604-60	796
18-605-30	796
18-605-40	796
18-605-50	796
18-605-60	796
18-606-30	796
18-606-40	796
18-606-50	796
18-606-60	796
18-607-00	797
18-608-00	797
18-609-00	797
18-610-00	797
18-611-00	797
18-612-00	797
18-613-00	797
18-614-00	797
18-615-00	797
18-616-00	797
18-617-00	797
18-618-00	797
18-619-00	797

18-620-00	797
18-621-00	797
18-622-00	797
18-623-00	797
18-624-00	798
18-625-00	798
18-626-00	798
18-627-00	798
18-628-00	798
18-629-00	798
18-630-00	798
18-631-00	798
18-632-00	798
18-633-00	798
18-634-00	798
18-635-00	798
18-636-00	798
18-637-00	798
18-638-00	798
18-639-00	798
18-640-00	798
18-641-00	799
18-642-00	799
18-643-00	799
18-644-00	799
18-645-00	799
18-646-00	799
18-647-00	799
18-648-00	799
18-649-00	799
18-650-00	799
18-651-00	799
18-652-40	800
18-652-50	800
18-652-60	800
18-653-40	800
18-653-50	800
18-653-60	800
18-654-40	800
18-654-50	800
18-654-60	800
18-655-40	800
18-865-50	800
18-655-60	800
18-656-40	801
18-656-50	801
18-656-60	801
18-657-40	801
18-657-50	801
18-657-60	801
18-658-40	801
18-658-50	801
18-658-60	801
18-659-40	801
18-659-50	801
18-659-60	801
18-660-40	801
18-660-50	801
18-660-60	801
18-661-40	801
18-661-50	801

18-661-60	801
18-662-40	801
18-662-50	801
18-662-60	801
18-663-40	801
18-663-50	801
18-663-60	801
18-664-40	801
18-664-50	801
18-664-60	801
18-665-18	802
18-666-23	802
18-667-23	802
18-668-00	802
18-669-00	802
18-670-23	803
18-671-23	803
18-672-23	803
18-673-23	803
18-674-17	804

## 19

Autopsy  
 Autopsie  
 Autopsia  
 Autopsie  
 Autopsia

19-101-27	806
19-102-28	806
19-103-28	806
19-104-22	806
19-105-13	806
19-127-00	807
19-128-00	807
19-129-00	807
19-130-00	807
19-131-00	807
19-106-00	808
19-107-10	808
19-116-00	808
19-108-16	808
19-117-11	808
19-119-12	808
19-121-15	808
19-118-11	808
19-120-12	808
19-122-15	808
19-109-13	809
19-109-01	809
19-109-02	809
19-109-03	809
19-110-13	809
19-114-01	809
19-115-01	809
19-114-03	809
19-114-02	809
19-115-02	809
19-114-04	809
19-114-00	809
19-115-00	809

19-114-04	809
19-115-05	809
19-114-06	809
19-111-00	810
05-901-14	810
05-923-14	810
04-181-14	810
04-190-14	810
06-239-14	810
06-240-14	810
08-888-00	810
06-214-12	810
09-812-14	810
02-377-14	810
02-375-14	810
19-116-00	810
03-505-03	810
03-502-04	810
19-112-00	811
05-901-14	811
05-923-14	811
04-181-14	811
04-190-14	811
06-239-14	811
06-240-14	811
08-888-00	811
06-214-12	811
09-812-14	811
02-377-14	811
02-375-14	811
19-114-00	811
19-115-00	811
19-116-00	811
03-505-03	811
03-502-04	811
19-113-00	812
19-119-12	812
19-120-12	812
19-114-01	812
19-115-01	812
05-901-14	812
19-123-00	812
03-505-03	812
03-502-04	812
05-976-12	812
05-177-11	812
19-124-00	813
03-505-03	813
03-502-04	813
04-181-14	813
04-190-14	813
05-177-11	813
19-114-01	813
19-115-01	813
05-901-14	813
05-976-14	813
19-123-00	813
19-125-00	814
03-505-03	814
03-502-04	814
04-181-14	814

04-771-14	814
05-901-14	814
05-924-14	814
19-116-00	814
06-214-12	814
06-215-12	814
09-812-14	814
02-377-14	814
02-375-14	814
03-512-20	814
19-126-00	815
03-505-03	815
03-502-04	815
04-181-14	815
09-812-14	815
05-915-12	815
05-901-14	815
03-512-11	815
04-688-11	815
19-109-13	815
19-110-13	815
19-109-03	815
03-501-03	815
19-127-00	816
05-976-12	816
19-130-00	816
03-502-04	817
03-512-22	817
19-119-12	817
19-131-00	817
19-109-03	817
19-128-00	817
03-502-04	817
03-512-22	818
05-901-14	818
05-923-14	818
19-114-00	818
19-114-06	818

## 20

Dermatology – Hollowware  
Dermatologie – Hohlware  
Dermatología – Hueco  
Dermatologie – Creuse  
Dermatologia – Hollowware

20-300-00	816
20-301-00	816
20-302-00	816
20-303-00	816
20-304-00	817
20-305-01	817
20-305-02	817
20-305-03	817
20-305-01	817
20-305-02	817
20-305-03	817
20-306-10	817
20-307-13	817
20-308-12	817
20-309-17	818

20-310-17	818
20-311-16	818
20-312-16	818
20-313-17	818
20-314-17	818
20-315-15	818
20-318-22	819
20-319-14	819
20-320-14	819
20-321-14	819
20-322-14	819
20-323-14	819
20-324-14	819
20-325-14	819
20-326-14	819
20-327-14	819
20-328-14	819
20-329-12	820
20-330-12	820
20-331-12	820
20-332-12	820
20-333-12	820
20-334-12	820
20-335-12	820
20-336-00	820
20-336-00	820
20-337-12	820
20-338-12	820
20-339-12	820
20-340-12	820
20-341-12	820
20-342-12	820
20-343-12	820
20-344-09	820
20-345-22	821
20-346-22	821
20-347-22	821
20-348-22	821
20-349-22	821
20-350-22	821
20-351-22	822
20-352-22	822
20-353-22	822
20-354-22	822
20-355-22	822
20-356-20	823
20-356-28	823
20-357-20	823
20-357-28	823
20-358-14	823
20-359-12	823
20-359-14	823
20-359-16	823
20-360-25	823
20-235-00	823
20-238-00	823
20-241-00	823
20-236-00	823
20-239-00	823
20-242-00	823
20-237-00	823

20-240-00	823
20-243-00	823
20-244-25	823
20-244-32	823
20-365-50	824
20-365-65	824
20-365-75	824
20-366-65	824
20-366-62	824
20-367-15	824
20-368-15	824
20-369-15	824
20-370-15	824
20-371-16	825
20-371-17	825
20-371-22	825
20-371-24	825
20-371-27	825
20-371-29	825
20-371-31	825
20-371-34	825
20-371-38	825
20-372-40	825
20-372-61	825
20-372-80	825
20-372-11	825
20-372-12	825
20-372-14	825
20-373-15	825
20-373-17	825
20-373-20	825
20-373-25	825
20-373-27	825
20-374-15	825
20-374-17	825
20-374-20	825
20-374-25	825
20-374-27	825
20-247-15	825
20-247-18	825
20-247-20	825
20-247-25	825
20-247-30	825
20-379-95	826
20-170-25	826
20-170-50	826
20-170-75	826
20-381-95	826
20-381-10	826
20-381-12	826
20-381-16	826
20-192-00	826
20-193-00	826
20-194-00	826
20-195-00	826
20-196-00	826
20-197-00	826
20-198-00	826
20-199-00	826
20-200-00	826
20-201-00	826

20-202-00	826
20-203-00	826
20-204-00	826
20-205-00	826
20-206-00	827
20-207-00	827
20-208-00	827
20-209-00	827
20-210-00	827
20-211-00	827
20-212-00	827
20-213-00	827
20-214-00	827
20-215-00	827
20-216-00	827
20-217-00	827
20-218-00	827
20-160-00	828
20-161-00	828
20-162-00	828
20-163-00	828
20-164-00	828
20-165-00	828
20-166-00	828
20-167-00	828
20-168-12	828
20-168-15	828
20-169-08	828
20-169-10	828
20-169-15	828
20-384-20	829
20-384-24	829
20-384-30	829
20-384-35	829
20-384-40	829
20-385-16	829
20-385-20	829
20-385-22	829
20-385-26	829
20-385-30	829
20-364-00	829
20-365-00	829
20-366-00	829
20-367-00	829
20-368-00	829
20-369-00	829
20-370-00	829
20-371-00	829
20-364-00	829
20-365-00	829
20-366-00	829
20-367-00	829
20-368-00	829
20-369-00	829
20-370-00	829
20-371-00	829
20-279-00	829
20-280-00	829
20-281-00	829
20-284-00	829
20-288-00	829

20-282-00	829
20-285-00	829
20-289-00	829
20-283-00	829
20-287-00	829
20-286-00	829
20-290-00	829
20-290-00	829
20-220-00	830
20-221-00	830
20-222-00	830
20-223-00	830
20-224-00	830
20-225-00	830
20-230-00	830
20-226-00	830
20-231-00	830
20-227-00	830
20-232-00	830
20-228-00	830
20-233-00	830
20-229-00	830
20-234-00	830
20-390-40	830
20-391-40	830
20-391-39	830
20-392-39	830
20-392-18	830
20-392-30	830
20-393-30	830
20-393-33	830
20-394-33	830
20-394-16	830
20-439-00	831
20-440-00	831
20-145-12	831
20-145-23	831
20-145-33	831
20-441-33	832
20-442-00	832
20-443-00	832

## 21

Sterilization  
 Sterilisation  
 Esterilización  
 Stérilisation  
 Sterilizzazione

21-444-01	838
21-444-02	838
21-444-03	838
21-444-04	838
21-444-05	838
21-444-06	838
21-445-01	838
21-445-02	838
21-445-03	838
21-445-04	838
21-445-05	838
21-445-06	838

21-446-01	838
21-446-02	838
21-446-03	838
21-446-04	838
21-446-05	838
21-446-06	838
21-447-01	838
21-447-02	838
21-447-03	838
21-447-04	838
21-447-05	838
21-447-06	838
21-444-01	838
21-444-02	838
21-444-03	838
21-444-04	838
21-444-05	838
21-444-06	838
21-445-01	838
21-445-02	838
21-445-03	838
21-445-04	838
21-445-05	838
21-445-06	838
21-448-01	838
21-448-02	838
21-448-03	838
21-448-04	838
21-448-05	838
21-448-06	838
21-449-01	838
21-449-02	838
21-449-03	838
21-449-04	838
21-449-05	838
21-449-06	838
21-450-01	838
21-450-02	838
21-450-03	838
21-450-04	838
21-450-05	838
21-450-06	838
21-451-01	838
21-451-02	838
21-451-03	838
21-451-04	838
21-451-05	838
21-451-06	838
21-454-01	839
21-454-02	839
21-454-03	839
21-454-04	839
21-454-05	839
21-454-06	839
21-455-01	839
21-455-02	839
21-455-03	839
21-455-04	839
21-455-05	839
21-455-06	839
21-456-01	839

21-456-02	839
21-456-03	839
21-456-04	839
21-456-05	839
21-456-06	839
21-457-01	839
21-457-02	839
21-457-03	839
21-457-04	839
21-457-05	839
21-457-06	839
21-458-01	839
21-458-02	839
21-458-03	839
21-458-04	839
21-458-05	839
21-458-06	839
21-459-01	839
21-459-02	839
21-459-03	839
21-459-04	839
21-459-05	839
21-459-06	839
21-460-01	839
21-460-02	839
21-460-03	839
21-460-04	839
21-460-05	839
21-460-06	839
21-461-01	839
21-461-02	839
21-461-03	839
21-461-04	839
21-461-05	839
21-461-06	839
21-462-01	839
21-462-02	839
21-462-03	839
21-462-04	839
21-462-05	839
21-462-06	839
21-463-01	839
21-463-02	839
21-463-03	839
21-463-04	839
21-463-05	839
21-463-06	839
21-464-01	840
21-464-02	840
21-464-03	840
21-464-04	840
21-464-05	840
21-465-01	840
21-465-02	840
21-465-03	840
21-465-04	840
21-465-05	840
21-466-01	840
21-466-02	840
21-466-03	840
21-466-04	840

21-466-05	840	21-474-04	843	21-484-04	846	21-494-05	847
21-466-06	840	21-474-05	843	21-484-05	846	21-494-06	847
21-467-01	840	21-474-06	843	21-484-06	846	21-495-01	847
21-467-02	840	21-475-01	843	21-485-01	846	21-495-02	847
21-467-03	840	21-475-02	843	21-485-02	846	21-495-03	847
21-467-04	840	21-475-03	843	21-485-03	846	21-495-04	847
21-467-05	840	21-475-04	843	21-485-04	846	21-495-05	847
21-467-06	840	21-475-05	843	21-485-05	846	21-495-06	847
21-548-01	841	21-475-06	843	21-485-06	846	21-496-01	847
21-548-02	841	21-476-01	843	21-486-01	846	21-496-02	847
21-548-03	841	21-476-02	843	21-486-02	846	21-496-03	847
21-548-04	841	21-476-03	843	21-486-03	846	21-496-04	847
21-545-01	841	21-476-04	843	21-486-04	846	21-496-05	847
21-545-02	841	21-476-05	843	21-486-05	846	21-496-06	847
21-545-03	841	21-476-06	843	21-486-06	846	21-497-01	847
21-545-04	841	21-477-01	843	21-487-01	846	21-497-02	847
21-611-03	841	21-477-02	843	21-487-02	846	21-497-03	847
21-612-05	841	21-477-03	843	21-487-03	846	21-497-04	847
21-610-07	841	21-477-04	843	21-487-04	846	21-497-05	847
21-610-08	841	21-477-05	843	21-487-05	846	21-497-06	847
21-610-09	841	21-477-06	843	21-487-06	846	21-498-01	847
21-610-10	841	21-478-01	843	21-488-01	846	21-498-02	847
21-468-01	842	21-478-02	843	21-488-02	846	21-498-03	847
21-468-02	842	21-478-03	843	21-488-03	846	21-498-04	847
21-468-03	842	21-478-04	843	21-488-04	846	21-498-05	847
21-468-04	842	21-478-05	843	21-488-05	846	21-498-06	847
21-468-05	842	21-478-06	843	21-488-06	846	21-499-01	847
21-468-06	842	21-479-01	843	21-489-01	846	21-499-02	847
21-469-01	842	21-479-02	843	21-489-02	846	21-499-03	847
21-469-02	842	21-479-03	843	21-489-03	846	21-499-04	847
21-469-03	842	21-479-04	843	21-489-04	846	21-499-05	847
21-469-04	842	21-479-05	843	21-489-05	846	21-499-06	847
21-469-05	842	21-479-06	843	21-489-06	846	21-500-01	847
21-469-06	842	21-480-01	844	21-490-01	846	21-500-02	847
21-470-01	842	21-480-02	844	21-490-02	846	21-500-03	847
21-470-02	842	21-480-03	844	21-490-03	846	21-500-04	847
21-470-03	842	21-481-01	844	21-490-04	846	21-500-05	847
21-470-04	842	21-481-02	844	21-490-05	846	21-500-06	847
21-470-05	842	21-481-03	844	21-490-06	846	21-501-01	847
21-470-06	842	21-482-01	844	21-491-01	846	21-501-02	847
21-471-01	842	21-482-02	844	21-491-02	846	21-501-03	847
21-471-02	842	21-482-03	844	21-491-03	846	21-501-04	847
21-471-03	842	21-482-04	844	21-491-04	846	21-501-05	847
21-471-04	842	21-482-05	844	21-491-05	846	21-501-06	847
21-471-05	842	21-482-06	844	21-491-06	846	21-502-01	847
21-471-06	842	21-483-01	844	21-492-01	846	21-502-02	847
21-472-01	842	21-483-02	844	21-492-02	846	21-502-03	847
21-472-02	842	21-483-03	844	21-492-03	846	21-502-04	847
21-472-03	842	21-483-04	844	21-492-04	846	21-502-05	847
21-472-04	842	21-483-05	844	21-492-05	846	21-502-06	847
21-472-05	842	21-483-06	844	21-492-06	846	21-503-01	847
21-472-06	842	21-551-01	845	21-493-01	846	21-503-02	847
21-473-01	842	21-551-02	845	21-493-02	846	21-503-03	847
21-473-02	842	21-551-03	845	21-493-03	846	21-503-04	847
21-473-03	842	21-551-04	845	21-493-04	846	21-503-05	847
21-473-04	842	21-611-02	845	21-493-05	846	21-503-06	847
21-473-05	842	21-612-04	845	21-493-06	846	21-504-01	848
21-473-06	842	21-610-08	845	21-494-01	847	21-504-02	848
21-474-01	843	21-484-01	846	21-494-02	847	21-504-03	848
21-474-02	843	21-484-02	846	21-494-03	847	21-504-04	848
21-474-03	843	21-484-03	846	21-494-04	847	21-504-05	848

21-505-01	848
21-505-02	848
21-505-03	848
21-505-04	848
21-505-05	848
21-506-01	848
21-506-02	848
21-506-03	848
21-506-04	848
21-506-05	848
21-506-06	848
21-507-01	848
21-507-02	848
21-507-03	848
21-507-04	848
21-507-05	848
21-507-06	848
21-554-01	849
21-554-02	849
21-554-03	849
21-554-04	849
21-611-01	849
21-612-03	849
21-610-04	849
21-610-05	849
21-610-06	849
21-610-07	849
21-508-01	850
21-508-02	850
21-508-03	850
21-508-04	850
21-508-05	850
21-508-06	850
21-509-01	850
21-509-02	850
21-509-03	850
21-509-04	850
21-509-05	850
21-509-06	850
21-510-01	850
21-510-02	850
21-510-03	850
21-510-04	850
21-510-05	850
21-510-06	850
21-511-01	850
21-511-02	850
21-512-01	850
21-513-01	851
21-513-02	851
21-513-03	851
21-513-04	851
21-513-05	851
21-513-06	851
21-554-01	851
21-554-02	851
21-612-03	851
21-611-01	851
21-628-02	851
21-610-04	851
21-610-05	851

21-514-01	852
21-514-02	852
21-514-03	852
21-514-04	852
21-514-05	852
21-514-06	852
21-515-01	852
21-515-02	852
21-515-03	852
21-515-04	852
21-515-05	852
21-515-06	852
21-516-01	852
21-516-02	852
21-516-03	852
21-516-04	852
21-516-05	852
21-516-06	852
21-517-01	852
21-517-02	852
21-517-03	852
21-517-04	852
21-517-05	852
21-517-06	852
21-518-01	852
21-518-02	852
21-518-03	852
21-518-04	852
21-518-05	852
21-518-06	852
21-519-01	852
21-519-02	852
21-519-03	852
21-519-04	852
21-519-05	852
21-519-06	852
21-520-01	853
21-520-02	853
21-520-03	853
21-521-01	853
21-521-02	853
21-521-03	853
21-522-01	853
21-522-02	853
21-522-03	853
21-522-04	853
21-522-05	853
21-522-06	853
21-612-01	854
21-628-01	854
21-610-01	854
21-523-01	855
21-524-01	855
21-525-01	855
21-526-01	856
21-526-02	856
21-526-03	856
21-527-01	856
21-612-02	856
21-610-01	856
21-610-02	856

21-610-03	856
21-528-01	857
21-528-02	857
21-528-03	857
21-528-04	857
21-528-05	857
21-528-06	857
21-529-01	857
21-529-02	857
21-529-03	857
21-529-04	857
21-529-05	857
21-529-06	857
21-530-01	858
21-531-01	858
21-532-01	859
21-532-02	859
21-532-03	859
21-532-04	859
21-532-05	859
21-532-06	859
21-533-01	859
21-533-02	859
21-533-03	859
21-533-04	859
21-533-05	859
21-533-06	859
21-534-01	859
21-534-02	859
21-534-03	859
21-534-04	859
21-534-05	859
21-534-06	859
21-535-01	860
21-536-01	860
21-636-02	860
21-537-01	860
21-537-02	860
21-537-03	860
21-537-04	860
21-537-05	860
21-537-06	860
21-538-01	860
21-538-02	860
21-538-03	860
21-538-04	860
21-538-05	860
21-538-06	860
21-539-10	861
21-539-20	861
21-540-01	861
21-540-02	861
21-540-03	861
21-540-04	861
21-540-05	861
21-541-01	862
21-541-02	862
21-541-03	862
21-541-04	862
21-542-01	862
21-542-02	862

21-542-03	862
21-543-01	863
21-543-02	863
21-543-03	863
21-543-04	863
21-545-01	863
21-545-02	863
21-545-03	863
21-545-04	863
21-546-01	863
21-546-02	863
21-546-03	863
21-546-04	863
21-548-01	863
21-548-02	863
21-548-03	863
21-548-04	863
21-547-00	863
21-549-01	864
21-549-02	864
21-549-03	864
21-549-04	864
21-551-01	864
21-551-02	864
21-551-03	864
21-551-04	864
21-552-01	864
21-552-02	864
21-552-03	864
21-552-04	864
21-554-01	864
21-554-02	864
21-554-03	864
21-554-04	864
21-553-00	864
21-555-01	865
21-555-02	865
21-555-03	865
21-559-01	865
21-559-02	865
21-559-03	865
21-556-00	865
21-557-01	865
21-557-02	865
21-557-03	865
21-560-01	865
21-560-02	865
21-560-03	865
21-558-00	865
21-561-01	865
21-561-02	865
21-561-03	865
21-563-01	865
21-563-02	865
21-563-03	865
21-562-00	865
21-564-01	865
21-564-02	865
21-564-03	865
21-566-01	865
21-566-02	865



21-566-03	865
21-565-00	866
21-567-01	866
21-567-02	866
21-567-03	866
21-568-00	866
21-569-00	866
21-570-00	866
21-571-00	866
21-572-00	866
21-573-01	867
21-573-02	867
21-573-03	867
21-573-04	867
21-573-05	867
21-573-06	867
21-573-07	867
21-573-08	867
21-573-09	867
21-573-10	867
21-573-11	867
21-573-12	867
21-573-13	867
21-573-14	867
21-573-15	867
21-573-16	867
21-573-17	867
21-573-18	867
21-573-19	867
21-574-01	867
21-574-02	867
21-575-01	867
21-575-02	867
21-576-01	868
21-577-01	868
21-578-01	868
21-576-02	868
21-577-02	868
21-578-02	868
21-576-03	868
21-577-03	868
21-578-03	868
21-576-04	868
21-577-04	868
21-578-04	868
21-579-01	868
21-580-01	868
21-581-01	868
21-579-02	868
21-580-02	868
21-581-02	868
21-579-03	868
21-580-03	868
21-581-03	868
21-579-04	868
21-580-04	868
21-581-04	868
21-582-01	868
21-583-01	868
21-584-01	868
21-582-02	868

21-583-02	868
21-584-02	868
21-582-03	868
21-583-03	868
21-584-03	868
21-582-04	868
21-583-04	868
21-584-04	868
21-585-01	868
21-586-01	868
21-587-01	868
21-585-02	868
21-586-02	868
21-587-02	868
21-585-03	868
21-586-03	868
21-587-03	868
21-585-04	868
21-586-04	868
21-587-04	868
21-588-01	868
21-589-01	868
21-590-01	868
21-588-02	868
21-589-02	868
21-590-02	868
21-591-01	868
21-592-01	868
21-593-01	868
21-594-14	868
21-595-20	868
21-596-00	869
21-597-00	869
21-598-00	869
21-599-00	869
21-600-00	869
21-601-00	869
21-602-00	870
21-602-00	870
21-602-00	870
21-605-01	870
21-605-02	870
21-606-00	870
21-607-00	870
21-607-00	870
21-607-00	870
21-609-01	870
21-609-02	870
21-609-03	870
21-609-04	870
21-609-05	870
21-609-06	870
21-609-07	870
21-609-08	870
21-610-01	870
21-610-02	870
21-610-03	870
21-610-04	870
21-610-05	870
21-610-06	870
21-610-07	870
21-610-08	870

21-610-09	870
21-610-10	870
21-611-01	871
21-611-02	871
21-611-03	871
21-612-01	871
21-612-02	871
21-612-03	871
21-612-04	871
21-612-05	871
21-613-00	871
21-614-00	871
21-615-01	871
21-615-02	871
21-615-03	871
21-615-04	871
21-615-05	871
21-616-01	871
21-616-02	871
21-617-01	872
21-617-02	872
21-617-03	872
21-617-04	872
21-617-05	872
21-617-01	872
21-617-02	872
21-617-03	872
21-617-04	872
21-617-05	872
21-618-00	872
21-619-00	873
21-620-00	873
21-621-01	873
21-621-02	873
21-621-03	873
21-621-04	873
21-622-01	873
21-622-02	873
21-623-01	873
21-623-02	873
21-624-00	873
21-625-00	873
21-626-00	873
21-627-01	874
21-627-02	874
21-627-03	874
21-627-04	874
21-627-05	874
21-627-06	874
21-628-01	874
21-628-02	874
21-628-03	874
21-628-04	874
21-628-05	874
21-628-06	874
21-629-00	874
21-630-01	874
21-630-02	874
21-630-03	874
21-630-04	874
21-631-01	875

21-631-02	875
21-631-03	875
21-631-04	875
21-632-01	875
21-632-02	875
21-632-03	875
21-632-04	875
21-633-01	875
21-633-02	875
21-633-03	875
21-633-04	875
21-634-01	875
21-634-02	875
21-634-03	875
21-634-04	875
21-635-00	875
21-636-00	875
21-637-00	875
21-638-00	875
21-639-00	876
21-640-00	876
21-641-00	876
21-642-00	876
21-643-00	876
21-644-00	876
21-645-00	876
21-646-00	876
21-647-00	876
21-648-00	877
21-649-00	877
21-650-00	877
21-651-00	877
21-652-00	877
21-638-00	877
21-654-00	878
21-655-00	878
21-656-00	878
21-657-00	878
21-658-00	878
21-659-00	878















comed  
operate better with us

 +44 (0) 161302 2744

 +44 (0) 161302 2734

 [sales@comedltd.co.uk](mailto:sales@comedltd.co.uk)

 [www.comedltd.co.uk](http://www.comedltd.co.uk)

 Ivy Mill Business Centre Manchester England M35 9BG